

OPEN BED FRAME

QUEEN

ASSEMBLY INSTRUCTIONS

Before assembling your bed frame, please read through these instructions carefully and familiarize yourself with the different parts.



PARTS LIST

①	FOOT RAIL	1 PC
②	LEFT LEG	1 PC
③	RIGHT LEG	1 PC
④	SIDE RAILS	2 PCS
⑤	SLAT KIT	2 SETS
⑥	SLAT SUPPORT 1	1 PC
⑦	SLAT SUPPORT 2	1 PC
⑧	SUPPORT LEGS	3 PCS

HARDWARE

①	JCB M6 X 110mm (4 3/8") - 2 pcs Spare - 1 pc	⑤	JCB M6 X 30mm (1 1/4") - 6pcs
②	Barrel nut - 2 pcs	⑥	Cap nut - 6pcs
③	JCB M8 X 15mm (5/8") - 4 pcs	⑦	Allen wrench M6 - 1pc
④	Wood screw (1 1/4") - 29 pcs Spare - 2 pcs	⑧	Allen wrench M4 - 1pc Spare - 1pc
		⑨	Split washer - 3pcs Spare - 1pc
		⑩	Flat washer - 3pcs Spare - 1pc

NOTE: WE INCLUDE SPARE HARDWARE IN CASE DAMAGE OCCURS DURING ASSEMBLY.

Step 1

Attach the legs (2) and (3) to foot rail (1), using JCB M6 X 110mm (A) and barrel nut (B).
Tighten with the Allen wrench M4 (I).

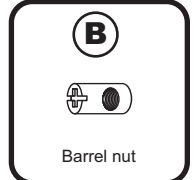
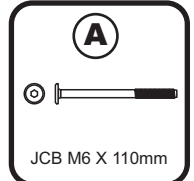
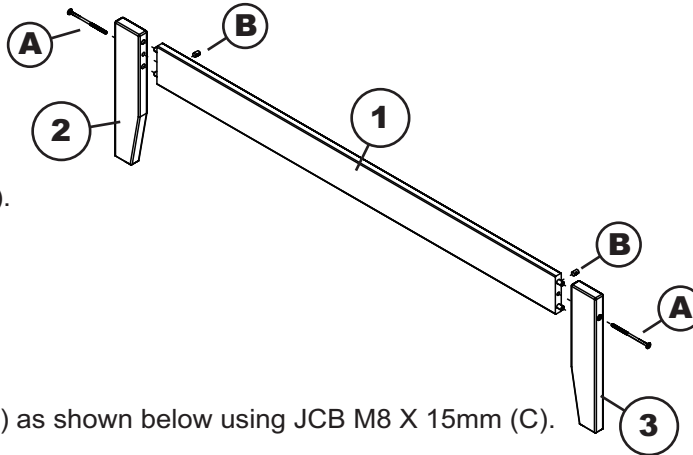

Step 2

Attach side rails (4) to the foot rail (1) as shown below using JCB M8 X 15mm (C).
Tighten with Allen wrench M6 (H).

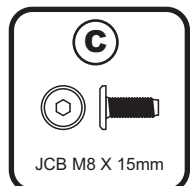
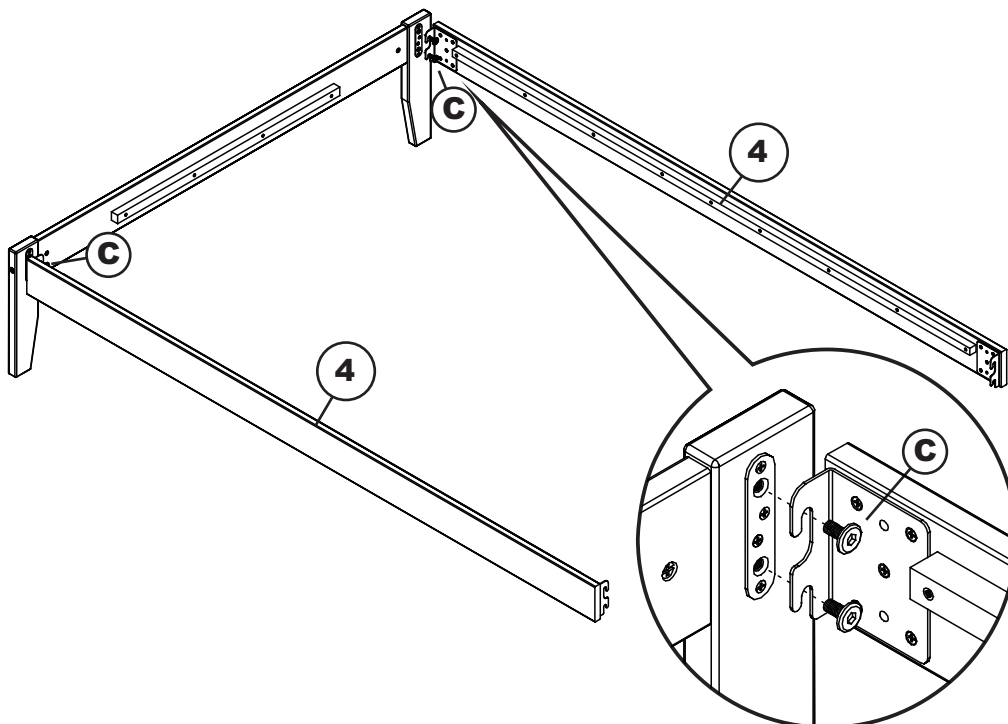

OPEN BED FRAME

QUEEN



Step 3

Attach open bed frame to the headboard as shown below using 4 JCB M8 X 15mm bolts that are supplied with your headboard. Tighten with the Allen wrench M6 (H).

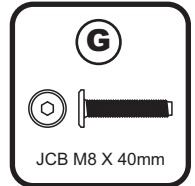
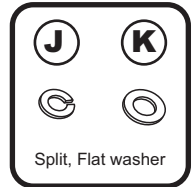
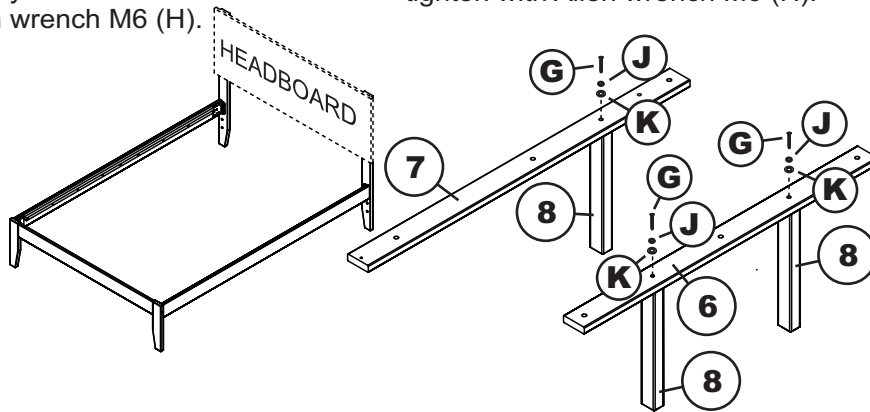
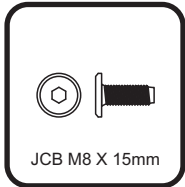

Step 5

Attach slat support 1(6) and slat support 2 (7) to the slat kit (5) as shown below using JCB M6 X 30mm (E) and cap nut (F). Tighten with Allen wrench M4 (I).

2 legs at headboard section.

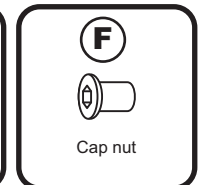
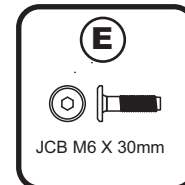
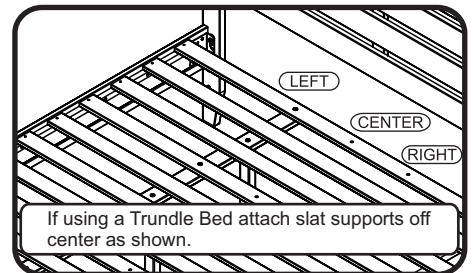
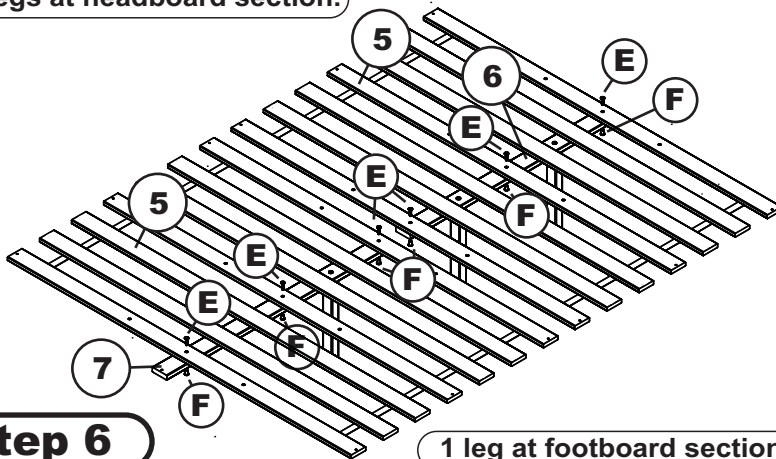

Step 6

Attach 2 slat kits (5) to the open bed frame as shown below using wood screws 1 1/4" (D). Tighten with Phillips head screw driver. (customer supplied)

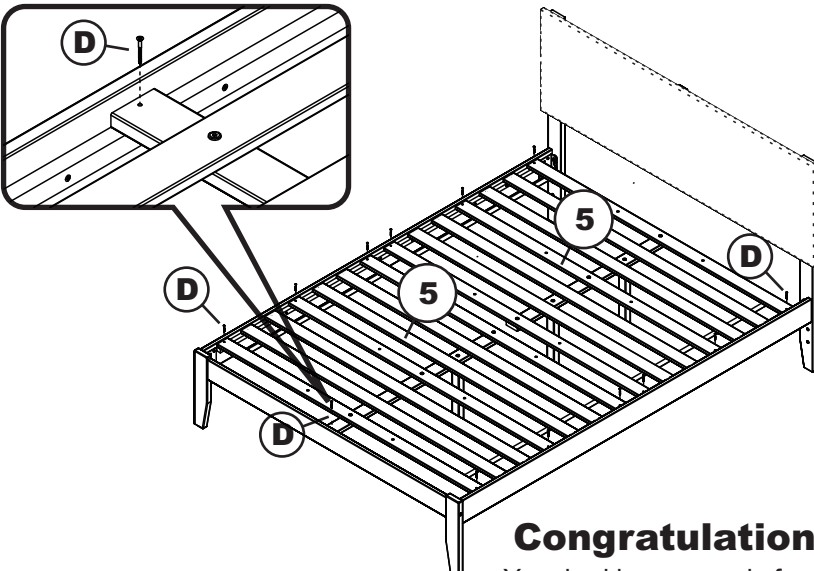

Congratulations!

Your bed is now ready for use.

We recommend that you periodically recheck that all screws are tight to ensure lasting safety.

HEADBOARD

ASSEMBLY INSTRUCTIONS

Before assembling your headboard, please read through these instructions carefully and familiarize yourself with the different parts.



PARTS LIST

- ① HEADBOARD PANEL BOARDS 4 PCS
- ② LEFT LEG 1 PC
- ③ RIGHT LEG 1 PC
- ④ HEADBOARD SUPPORT 1 PC

Instructions apply for bed sizes
FULL > QUEEN

HARDWARE

- | | | |
|---|--|--|
| <ul style="list-style-type: none"> ① JCB M6 X 35mm - 16 pcs
Spare - 1 pc ② JCB M8 X 15mm (5/8") - 4 pcs
<i>Assembly headboard to open bed frame</i> | <ul style="list-style-type: none"> ③ Allen wrench - 1 pc
Spare - 1 pc ④ Wood screw 1 1/4"-4 pcs
Spare - 1 pc | <p>HARDWARE FOR METAL BED FRAME</p> <ul style="list-style-type: none"> ⑤ JCB M6 X 25mm (1") - 4 pcs
Spare - 1 pc ⑥ Flat washer - 4 pcs
Spare - 1 pc ⑦ Split washer - 4 pcs
Spare - 1 pc |
|---|--|--|

NOTE: WE INCLUDE SPARE HARDWARE IN CASE DAMAGE OCCURS DURING ASSEMBLY.

Step 1

Attach the legs (2) and (3) to headboard panel boards (1) using JCB M6 X 35mm (A). Tighten with the Allen wrench (G).

Step 2

Attach headboard support (4) to headboard panel boards using wood screw 1 1/4" (C) Tighten with the Phillips head screw driver. (Customer supplied)

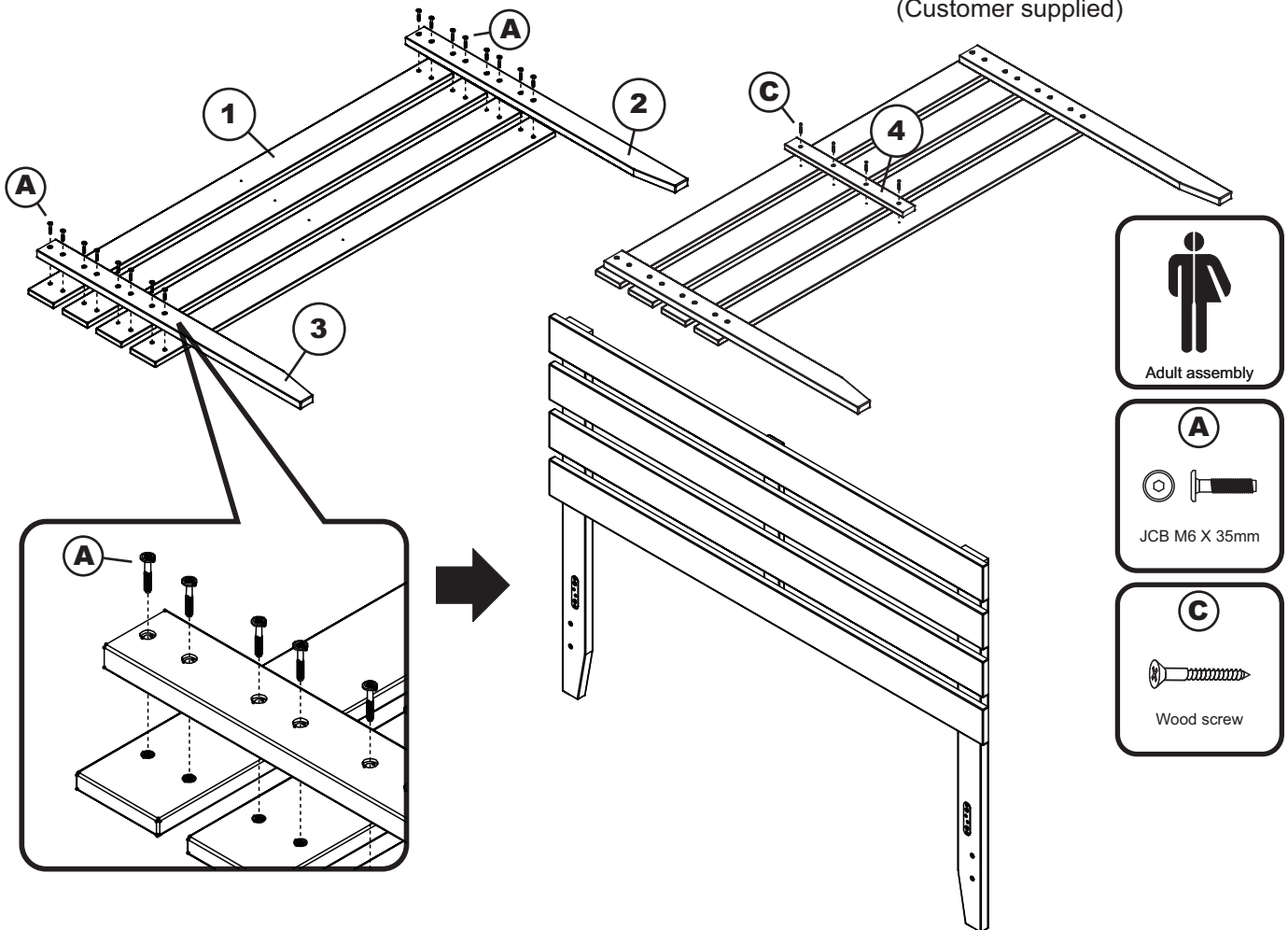

FOR BED FRAME ASSEMBLY follow assembly instructions included with your bed frame. If you purchased a wood headboard to attach to metal bed frame, please refer to page 2.

ATTACHING HEADBOARD TO METAL BED FRAME

ASSEMBLY INSTRUCTIONS

Before assembling your bed, please read through these instructions carefully and familiarize yourself with the different parts.

Instructions apply for bed sizes
Twin > Full > Queen



Adult assembly

Metal bed frames are sold separately from wood headboards. The hardware shown on this page is supplied with your wood headboard for attaching the bed frame to the headboard. The metal bed frame is supplied with its own assembly instructions and hardware.

Step 1

Attach the headboard assembly to the metal bed frame using JCB M6 X 1" (D), flat washer (E), and split washer (F) then tighten with Allen wrench (G) as shown below.

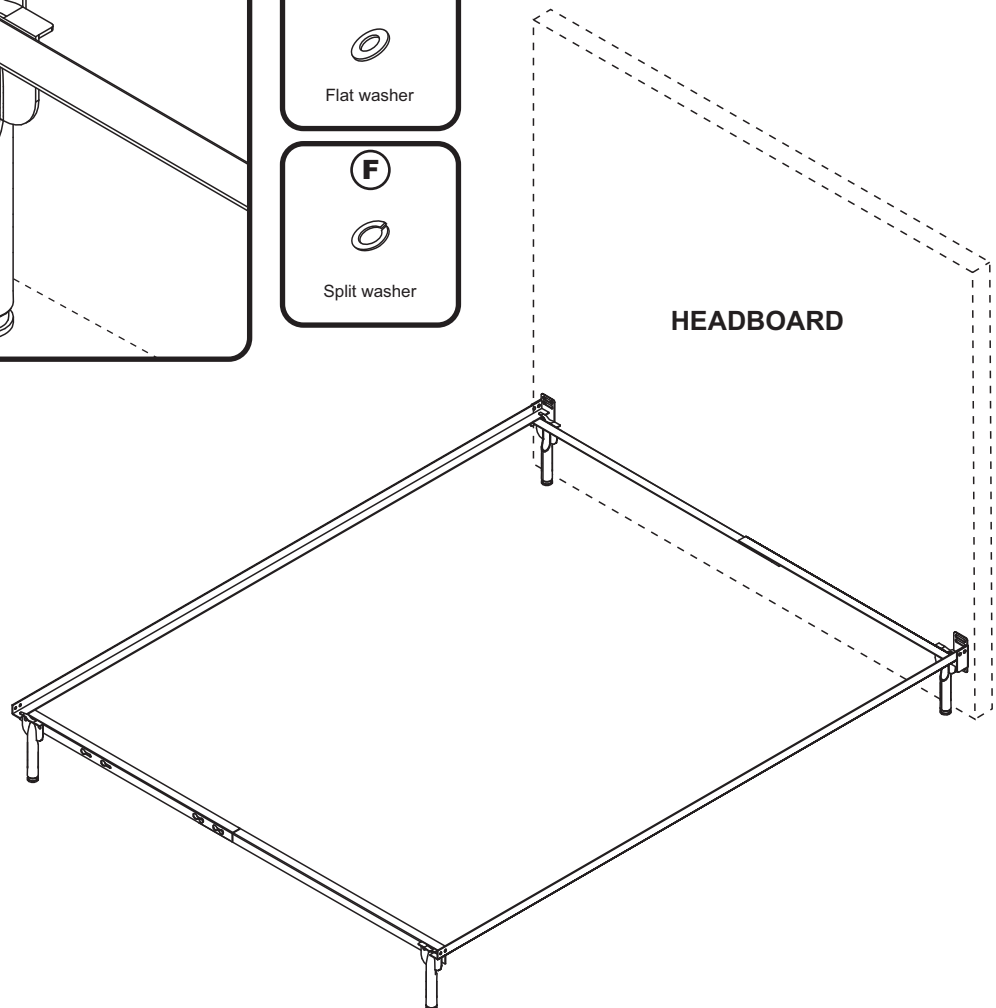
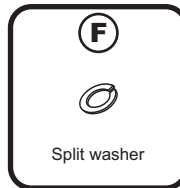
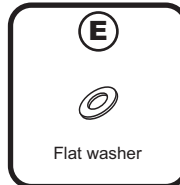
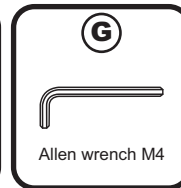
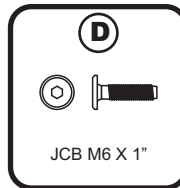
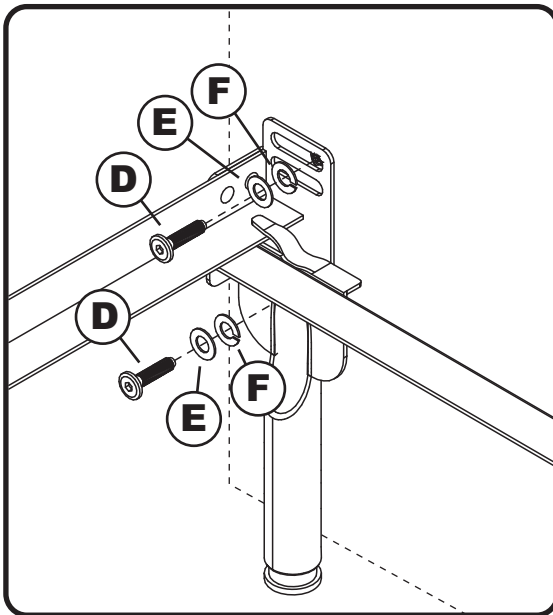

Congratulations!

Your bed is now ready for use.

To ensure lasting safety, we recommend that you periodically check that all screws are tight and all parts are secure.

BED DRAWER

TWIN XL / QUEEN ASSEMBLY INSTRUCTIONS

Before assembling your bed drawer, please read through these instructions carefully, familiarize yourself with the different parts.

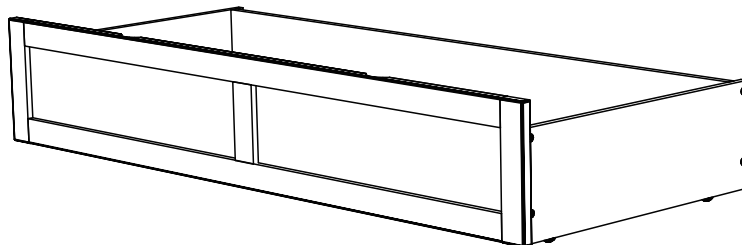
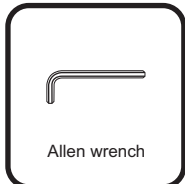

NOTE: WE INCLUDE SPARE HARDWARE IN CASE DAMAGE OCCURS DURING ASSEMBLY.

HARDWARE

- A** JCB M6 X 1" (25mm) - 16 pcs
Spare - 1 pc
- B** Wood Screw X 1 1/4" (32mm) - 4 pcs
Spare - 1 pc
- C** Allen wrench - 1 pc
Spare - 1 pc

PARTS LIST

- 01** HARDWARE 1 BOX
- 02** DRAWER FACE 1 PC
- 03** DRAWER SIDE 2 PCS
- 04** DRAWER BACK 1 PC
- 05** DRAWER BOTTOM 2 PCS
- 06** DRAWER MIDDLE 1 PC
- 07** DRAWER CENTER SUPPORT 1 PC

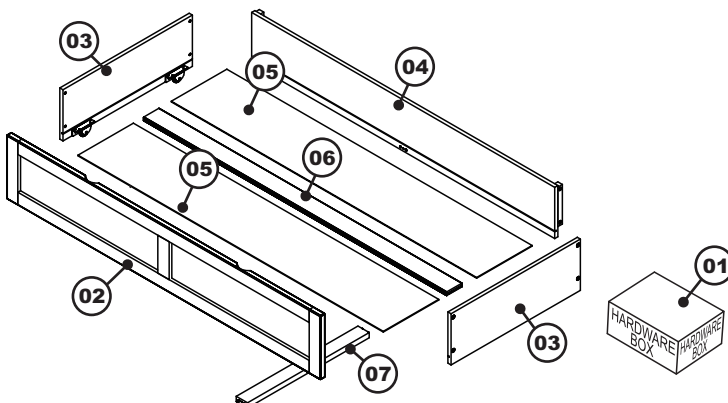

Step 1

Lay the drawer face (02) on smooth, flat surface so the drawer bottom (05) groove is facing upwards. Attach the drawer sides (03) to drawer face (02) using JCB M6 X 1" (A). Align groove inside drawer side with groove in drawer face. Tighten with Allen wrench (C).

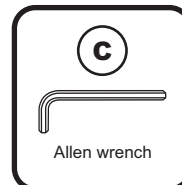
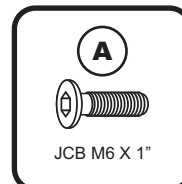
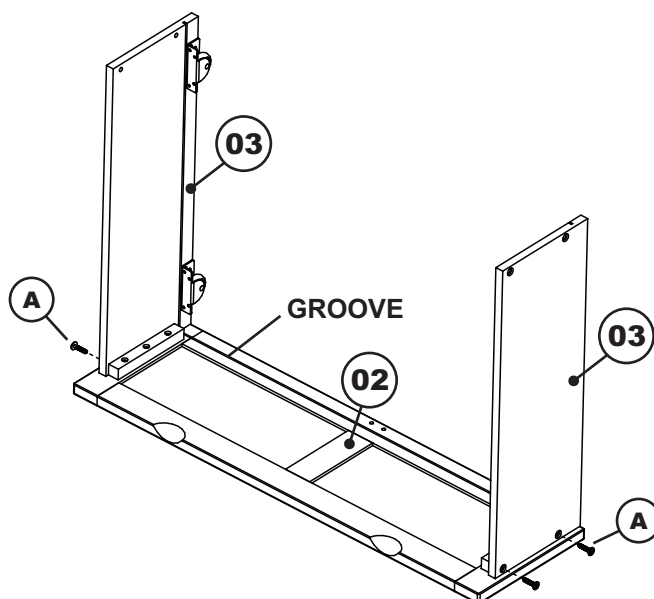

TWIN XL / QUEEN

Step 2

Guide the drawer bottoms (05) and drawer middle (06) in carefully so that they align inside grooves. Be sure it fits fully into the face and side groove before attaching the drawer back (04). Attach drawer center support (07) to bottom of drawer face using wood screw 1 1/4" (B). Tighten with Phillips head screw driver. (Customer supplied)

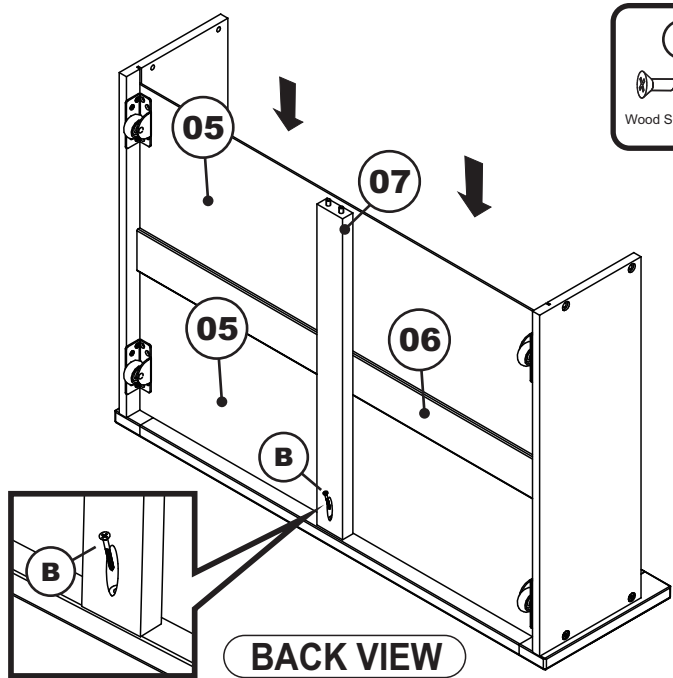
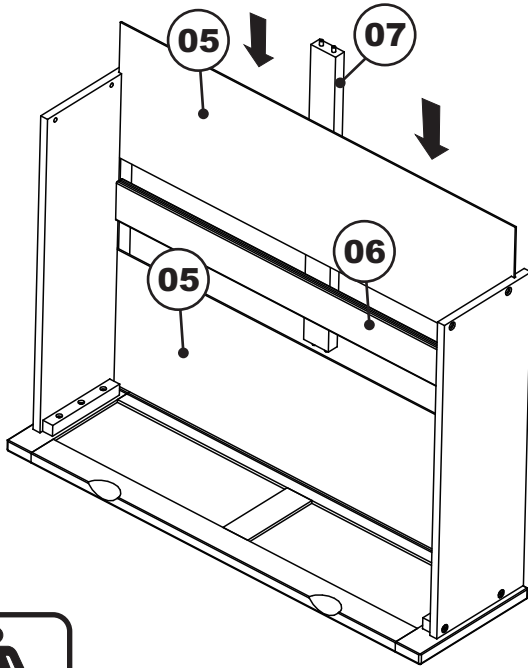

Adult assembly

Step 3

Attach drawer back (04) to bed drawer assembly as shown. Use JCB M6 X 1" (A). Tighten with Allen wrench (C). Use wood screws 1 1/4" (B) to finish attaching drawer center support (07) to drawer back (04). Tighten with Phillips head screw driver. (customer supplied)

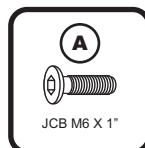
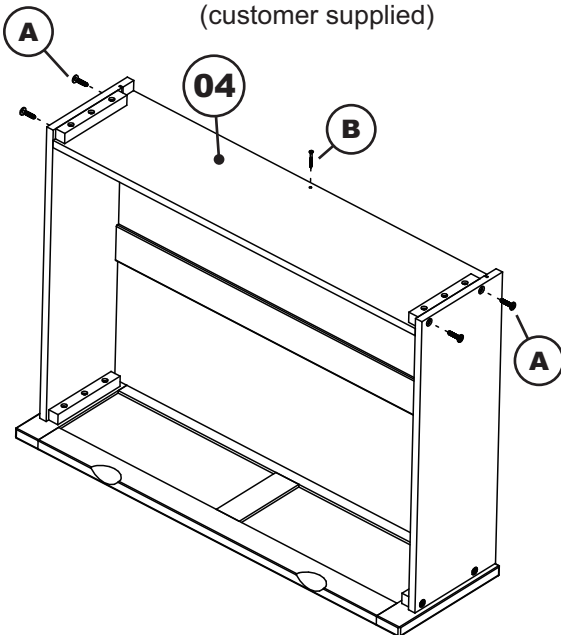

JCB M6 X 1"



Wood Screw 1 1/4"

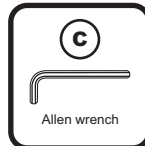

Allen wrench

Step 4

Lastly, insert bed drawer to the bed as shown below.

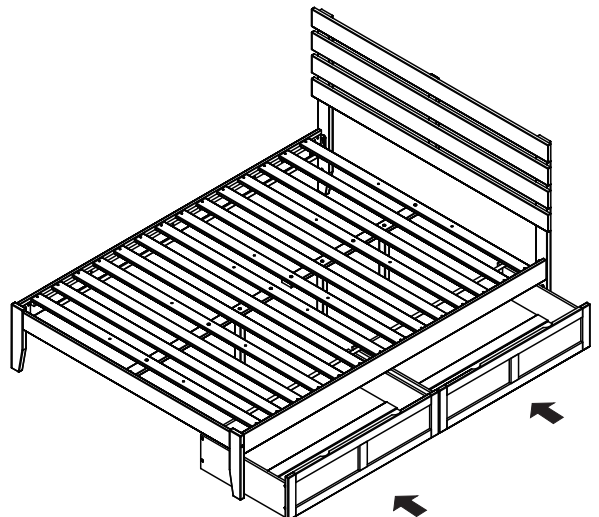

Adult assembly

Congratulations!

Your bed drawer is now ready for use. We recommend that you periodically recheck that all screws are tight to ensure lasting safety.