

# ASSEMBLY INSTRUCTIONS

Read this instruction carefully. See hardware and Furniture part list for guidance.  
 Be sure all parts are complete, before you assemble. Pace all wooden prevent from being scratched.  
 Follow the figure to start assembling.

**CAUTIONS:** 1. Do not FULLY- TIGHTEN the nut or bolt until all nut and bolt is ready assembled.  
 2. Do not OVER - TIGHTEN the nut or bolt avoid causing damages to the thread.  
 3. Keep all hardware parts out of reach of children.

PART LIST		
ITEM	DESCRIPTION	QTY
A	CHAIR BACK	1 PC
B	SIDE PANEL (L & R)	2 PCS
C	FRONT FRAME	1 PC
D	STRETCHER	2 PCS
E	CUSHION SEAT	1 PC

HARDWARE LIST		
ITEM	DESCRIPTION	QTY
1	WOOD DOWEL M8 x 30 MM 	6 PCS
2	JCBC SCREW M6 x 50 MM 	6 PCS
3	SPRING WASHER M6 	6 PCS
4	FLAT WASHER M6 x 13 MM 	6 PCS
5	CSK SCREW M4 x 32 MM 	9 PCS
6	ALLEN KEY M4 	1 PC

NOTE: THE LIST AND QUANTITY SHOWN ARE FOR 1 UNIT ASSEMBLY.

## STEP 01

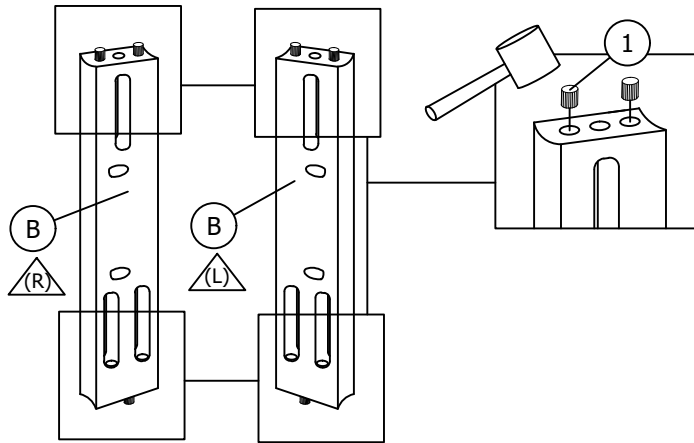

## STEP 02

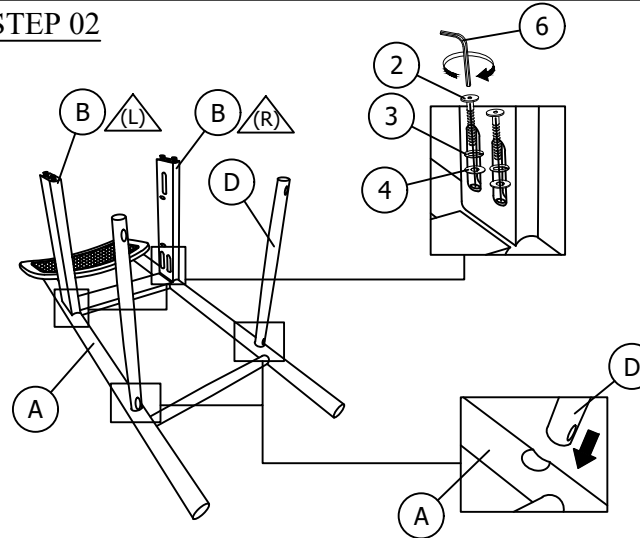

## STEP 03

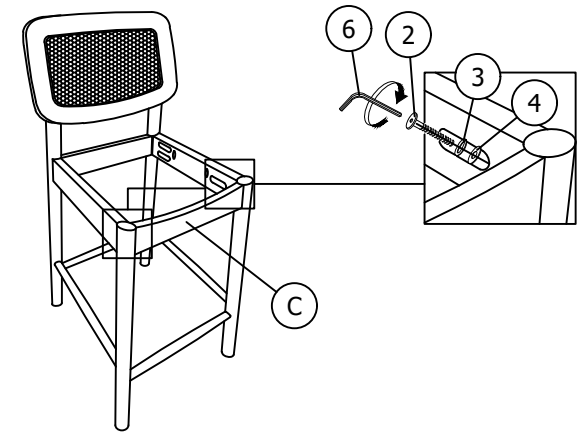

## STEP 04

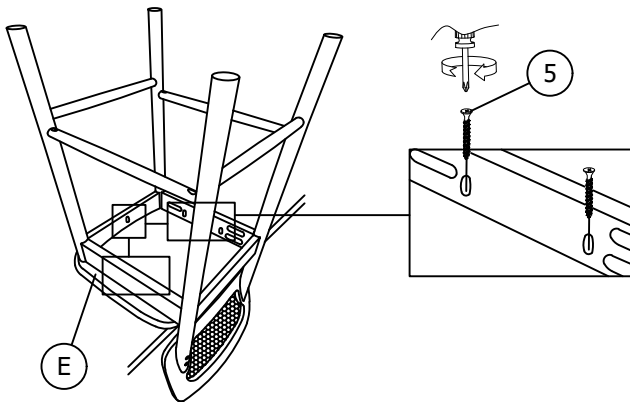

## STEP 05

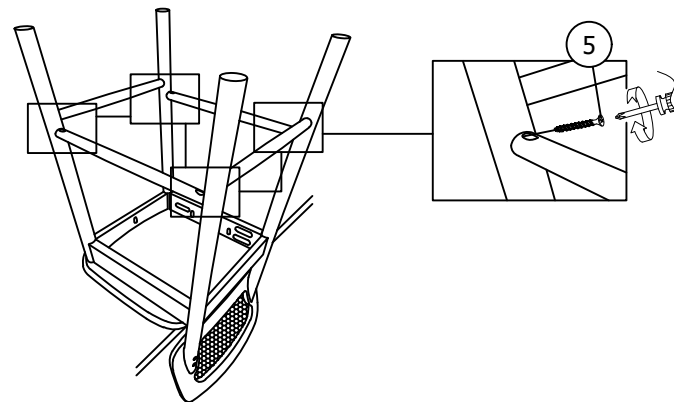

## STEP 06

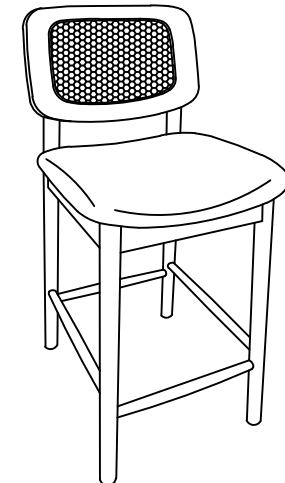

FULLY SET-UP (CHAIR)