

Twin Over Full Bunk bed

Congratulations on the purchase of your Twin Over Full Bunk bed. This bed has been crafted to the highest standards of quality and safety and will give you many years of enjoyment and practical use. Your bunk bed can be separated into two individual twin beds if the need arises for alternate sleeping configurations.

Several basic safety considerations must be adhered to when using this bunk bed.

TO HELP PREVENT serious or fatal injury from entrapment or falls:

- Never allow a child under 6 years on upper bunk
- Always use the recommended size mattresses or mattress supports – standard twin 38" x 74" (96.5 cm x 188 cm) on upper bed and standard full 54" x 74" (137.2cm x 188cm) on lower bed – to help prevent the likelihood of entrapment or falls
- Ensure thickness of mattress does not exceed 9" (22.9 cm) for the upper bed
- Surface of mattress must be at least 5" (12.7 cm) below upper edge of safety rails
- Always use safety rails on both sides of upper bunk
- Do not allow horseplay on or under bed(s) and prohibit jumping on the bed(s)
- Prohibit more than one person on upper bed
- If the bunk will be placed next to a wall, the safety rail that runs the full length of the bed should be placed against the wall to prevent entrapment between the bed and the wall
- Follow the information on the warning labels appearing on the upper bunk end board and on the carton
- Do not remove warning label from bed
- Periodically check and ensure that the safety rails, ladder and other components are in their proper positions, free from damage, and that all connectors are tight
- Do not use substitute parts
- Contact manufacturer or dealer for replacement parts
- The use of a water or sleep flotation mattress is prohibited
- Keep these instructions for future reference
- Use of a night light may provide added safety precaution for a child using the upper bunk
- STRANGULATION HAZARD- Never attach or hang items to any parts of the bunk bed that are not designed for use with the bed, including but not limited to hooks, belts or jump ropes

On this insert you will find a list of the hardware and bunk bed parts included, as well as detailed assembly instructions. Assembly is quite simple, and requires only a flat head screwdriver and a Phillips head screwdriver. The use of a power drill with Phillips head attachment is helpful but not necessary. Assembly will be most easily accomplished if you take the time to carefully sort the hardware and familiarize yourself with the function of each piece.

Thank you and Enjoy

HARDWARE LIST



16x **100mm bolts**
Used to connect end boards to side rails

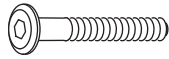

8x **35mm bolts**
Used to attach safety rails to bunk

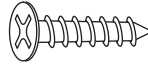

56x **25mm slat screws**
Used to secure slats to rails

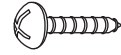

2x **15mm Round Screws**
Used to secure ladder hooks to upper bed rail



16x **Barrel nuts**
Used to secure bolts

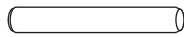

4x **Bunk connector pins**
Used to connect upper bunk to lower bunk

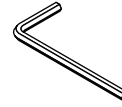

1x **Hex Key**
Used to tighten bolt hardware

Guide

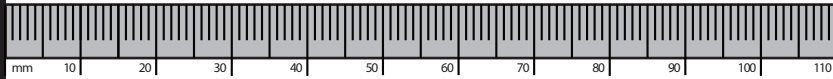

BUNK BED PARTS

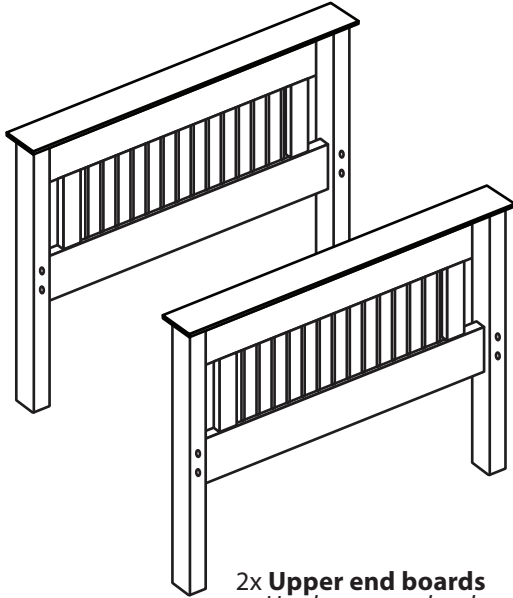

2x **Upper end boards**
Used on upper bunk

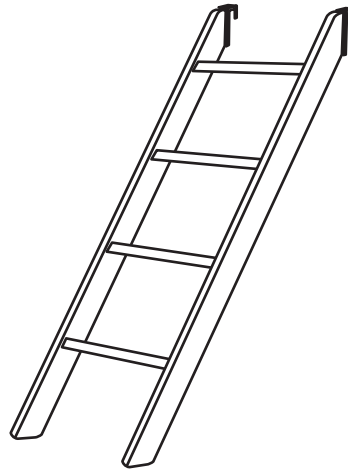

1x **Ladder**
For access to upper bunk

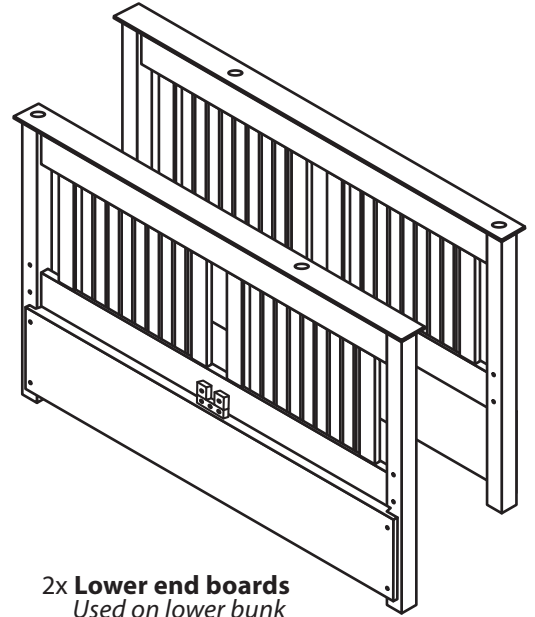

2x **Lower end boards**
Used on lower bunk

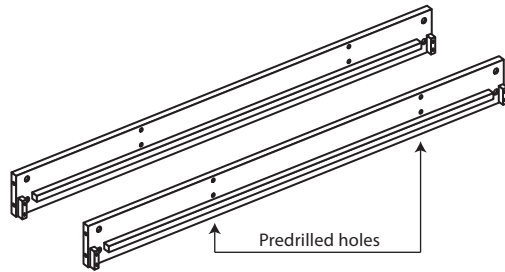

2x **Side rails**
Used to connect the upper end boards

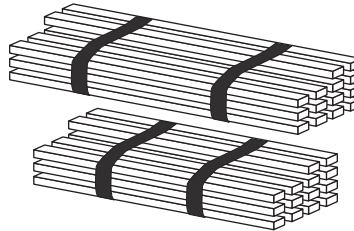

2x **Slat bundles**
Rest on side rails (strap side down)

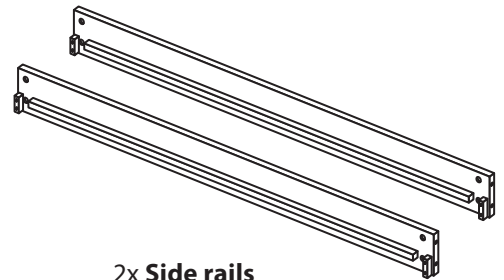

2x **Side rails**
Used to connect the lower end boards

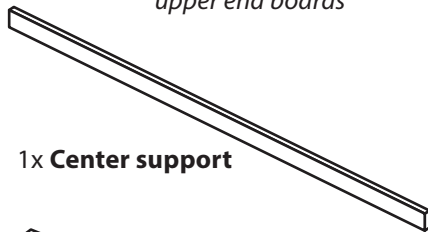

1x **Center support**

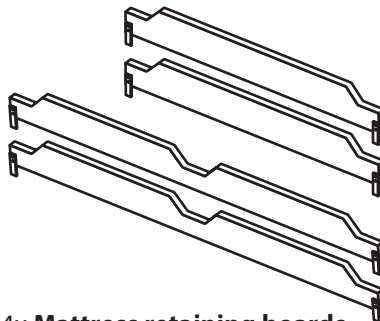

4x **Mattress retaining boards**
Used to secure mattresses

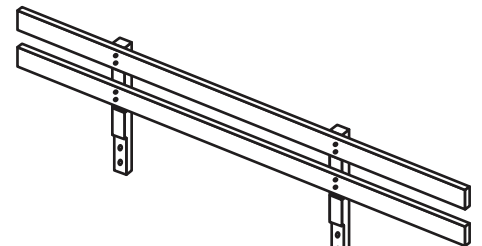

1x **Long safety rail**
Used on upper bunk (wall side of bunk)

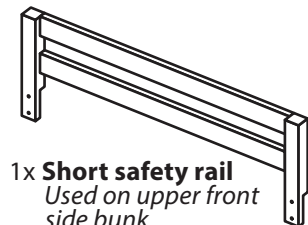

1x **Short safety rail**
Used on upper front side bunk

1

Assemble the twin upper bed by attaching the short end boards to the upper bed side rails with the pre-drilled holes for safety rail attachment.

Insert barrel nuts into side rails. Insert 100mm bolts through end boards and into the barrel nuts.

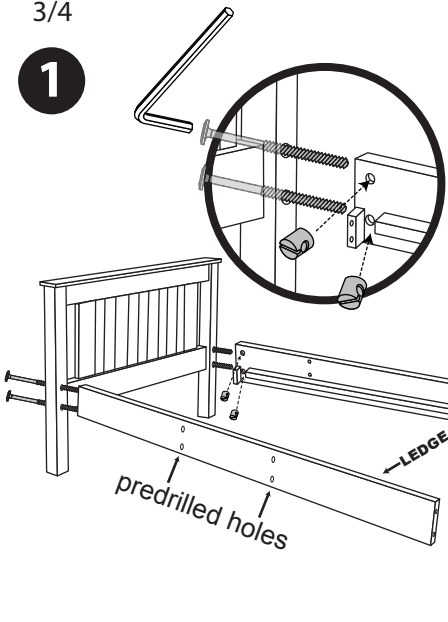

Tighten 100mm bolts with the 5mm hex key provided.

2

Unroll the slat bundle (strap side down) onto side rails, distributing them evenly from end to end.

Secure the slats to the side ledges with 25mm slat screws using a Phillips head screwdriver.

****Note:** A power screwdriver with clutch set on low is useful here.

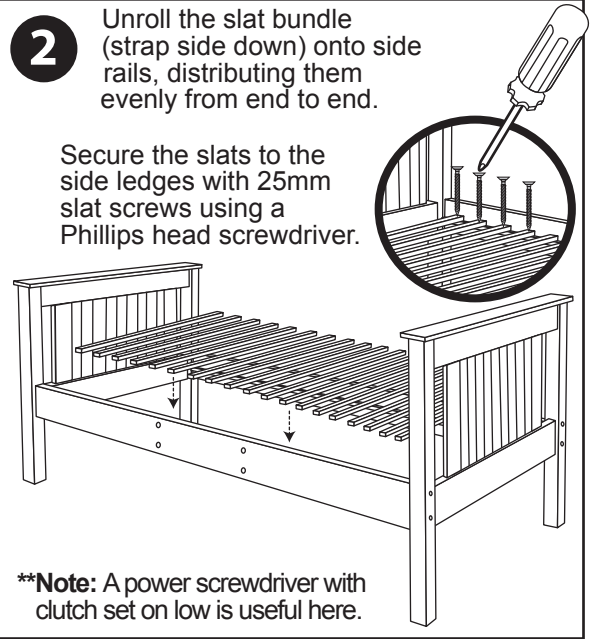

3

Insert mattress retaining board between the head board and the wooden block on the end of the side rail.

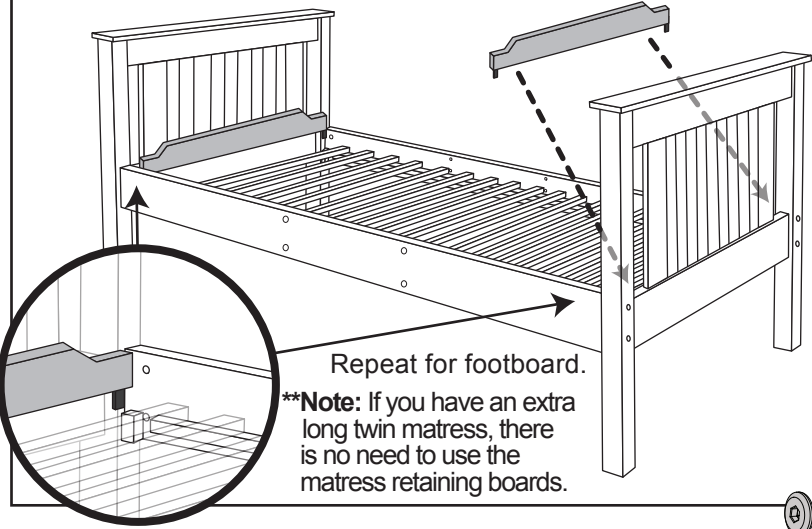

Repeat for footboard.

****Note:** If you have an extra long twin mattress, there is no need to use the mattress retaining boards.

4

Use 35mm bolts to attach the long safety rail to the side rail on the back wall side of the upper bed.

Attach the short safety rail to ladder side of the upper bed.

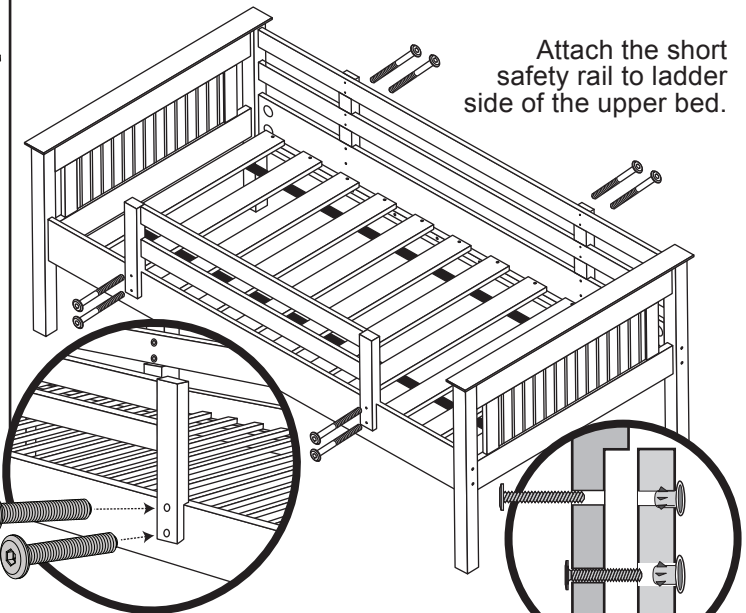

****Note:** Propel nuts are pre-installed into the bed rails and face away from the 35mm bolts as shown.

5

To assemble the lower bunk repeat step 1 using the parts for the lower bunk.

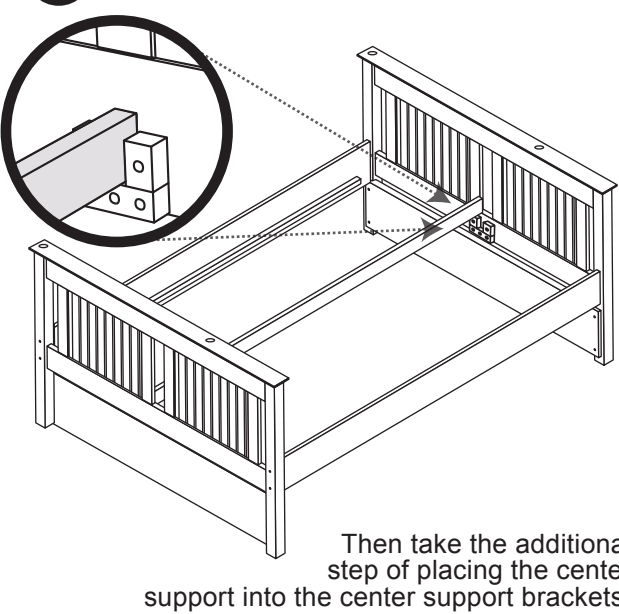

Then take the additional step of placing the center support into the center support brackets.

6

Next unroll the slat bundle (strap side down) onto side rails, distributing them evenly from end to end.

Secure the slats to the side ledges with 25mm slat screws using a Phillips head screwdriver.

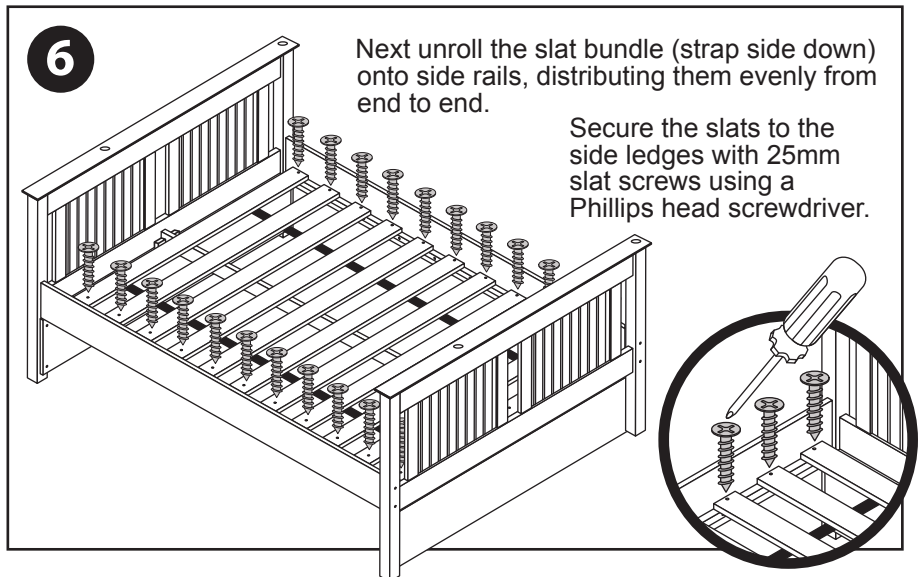

- 7** Insert full mattress retaining board between the headboard and the wooden block on the end of the side rail.

Repeat for footboard.

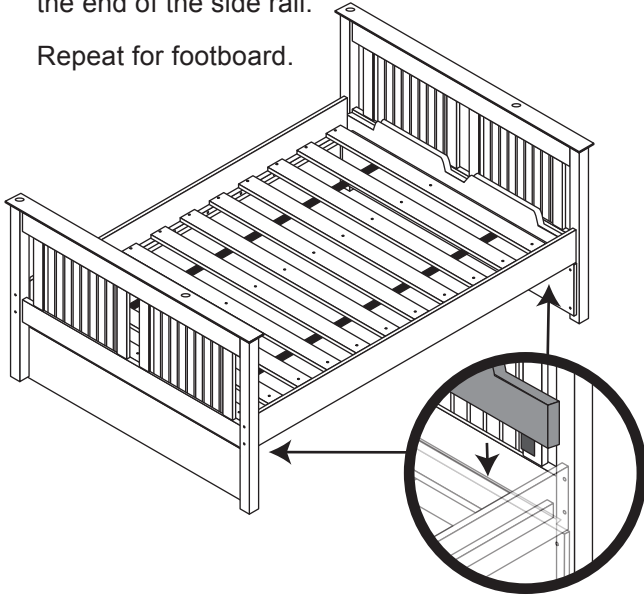

8

Insert a bunk connector pin into each of the four holes on the bottom end boards.

With the assistance of another person place the upper bunk on top of the lower bunk.

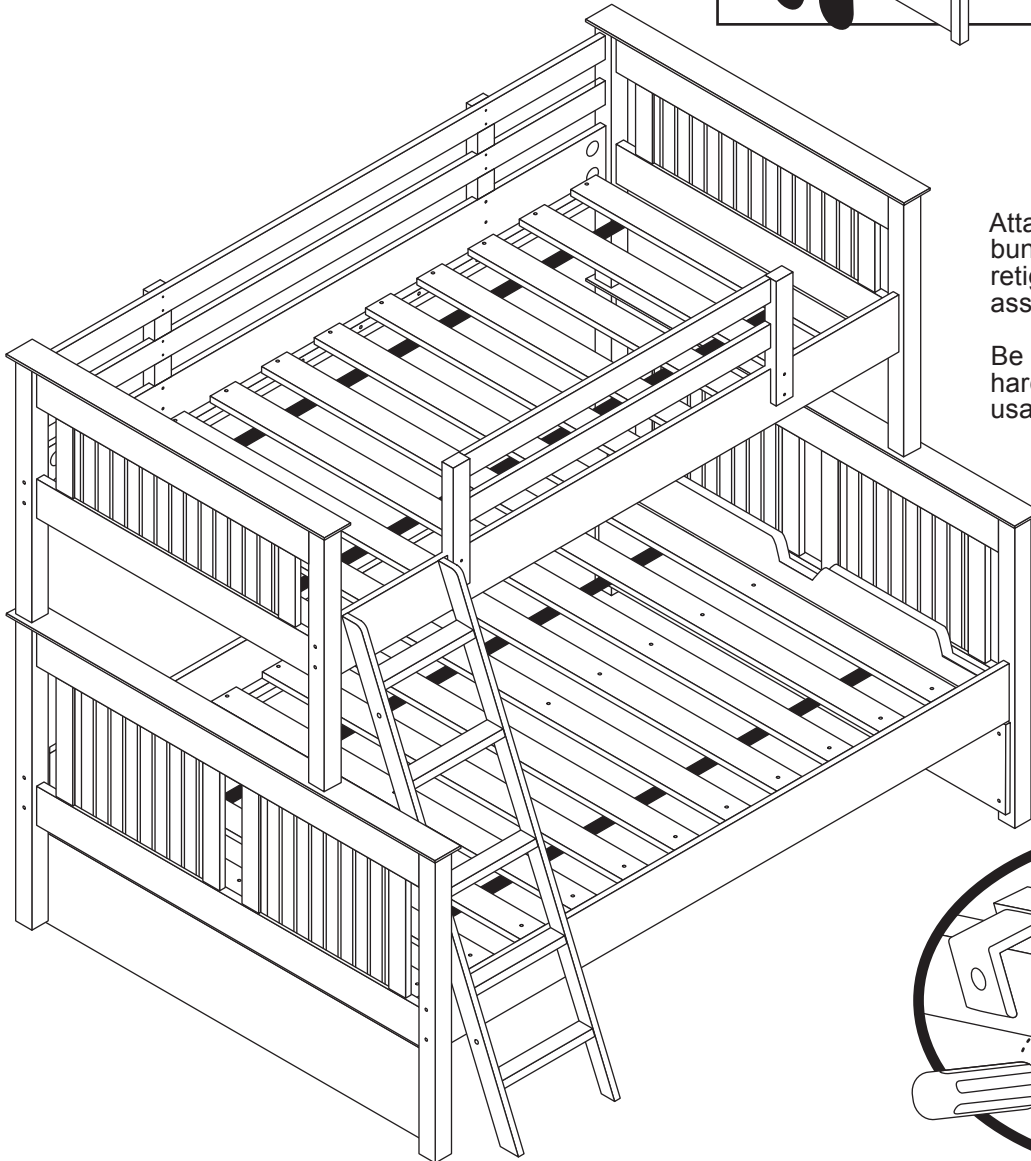
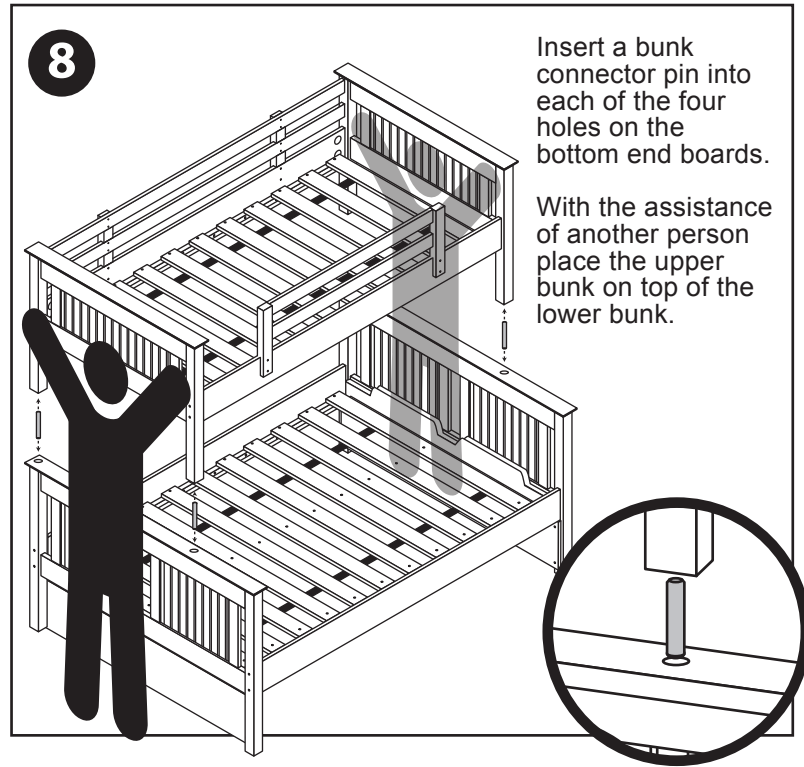

Attach ladder to side rail of upper bunk. Now use the hex key to retighten all bolts so that bunk bed assembly is rigid.

Be sure to periodically tighten hardware, as it may loosen with usage and changing humidity.

If desired, you may permanently affix the ladder with two 15mm wood screws.

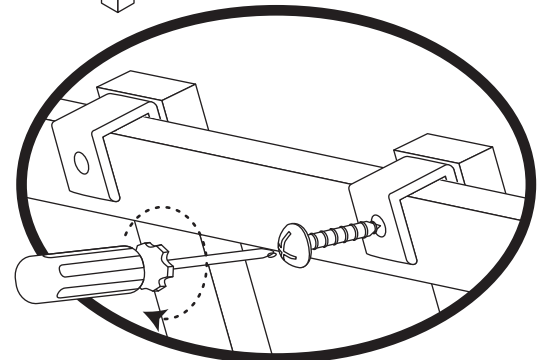

****Note:** Do not affix ladder if you have purchased under bunk drawer.