



MFL



MAVENLANE.COM

Eva Stool



ABOUT US

As unique individuals, we all have our own ways of expressing ourselves. Through expression, we open doors to new opportunities and communicate to the world.

At Maven Lane, we understand the profound impact that home design can have on personal expression. Our homes serve as our nests, reflecting our individual styles, personalities, and values. They are the spaces where we create meaningful memories and moments of comfort and peace.

With this in mind, we set out to bring the finest in design, materials, and customer service directly to our customers, all at an attainable price point. Whether you're seeking to elevate your mornings with a cozy sanctuary or host laughter-filled dinners with loved ones, we are dedicated to helping you create a space that truly reflects who you are and what you aspire to be.



ASSEMBLY INSTRUCTIONS

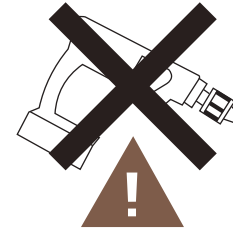
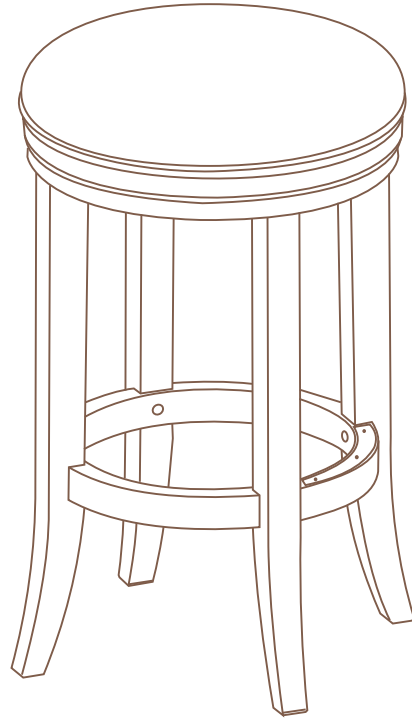

The use of power tools to assemble this product could lead to damage, making it unsafe

Please assemble on a clean, level surface to avoid damage and ensure proper assembly

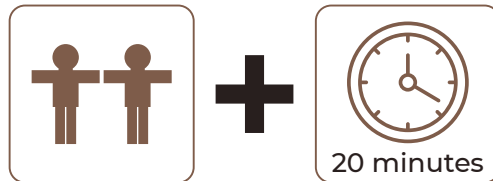

Tools Required

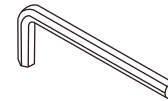

Allen Key
(included)

PARTS LIST

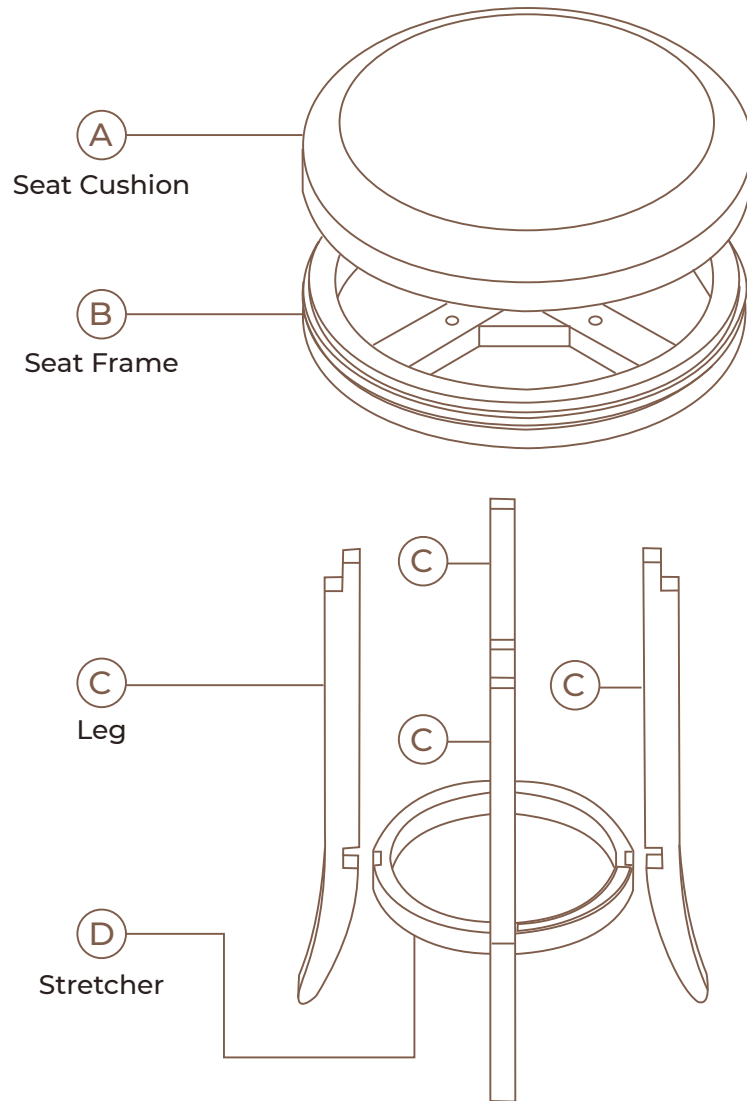

E  Qty 16
1/4"x35mm Bolt

H  Qty 4
1/4"x15mm Bolt

F  Qty 20
1/4"x \varnothing 9x1.5mm

I  Qty 1
Swivel Base

G  Qty 20
1/4"x \varnothing 16x1.5mm

J  Qty 1
Allen Key

Scan for video instructions



K  Qty 6
Felt Pads

ASSEMBLY

STEP 1

Insert stretcher (D) into the joint of legs (C). Note the kickplate on stretcher (D) must face up. Attach legs with bolts (E), lock washers (F), and flat washers (G) using Allen key (J). Do not fully tighten yet.

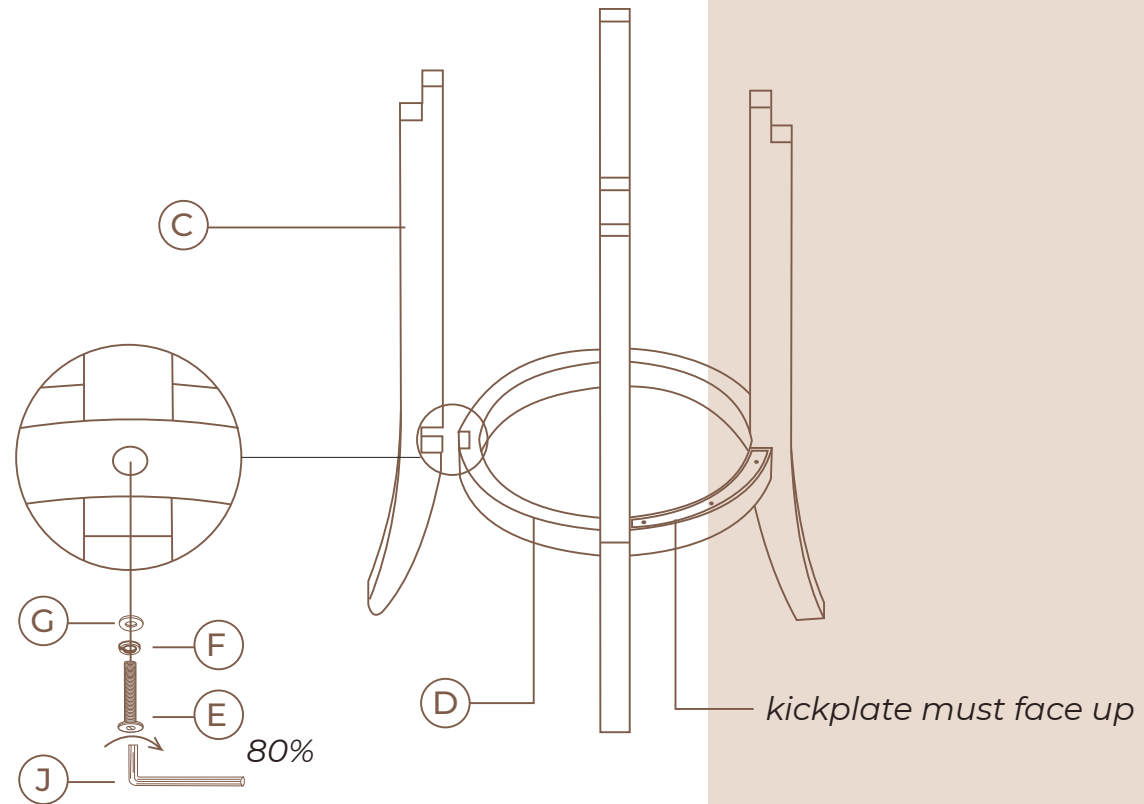

ASSEMBLY

STEP 2

The two sides of the swivel base are different. One side contains round holes, the other side contains slotted holes.

Using slotted holes on swivel base (I), attach swivel base (I) to seat cushion (A) with bolts (H), lock washers (F), and flat washers (G), using Allen key (J).

Find the "swivel" sticker on the seat frame (B). Match this side of seat frame (B) to swivel base (I). Align holes.

Attach the seat frame (B) with bolts (E), lock washers (F), and flat washers (G) using Allen key (J). Fully tighten all bolts.

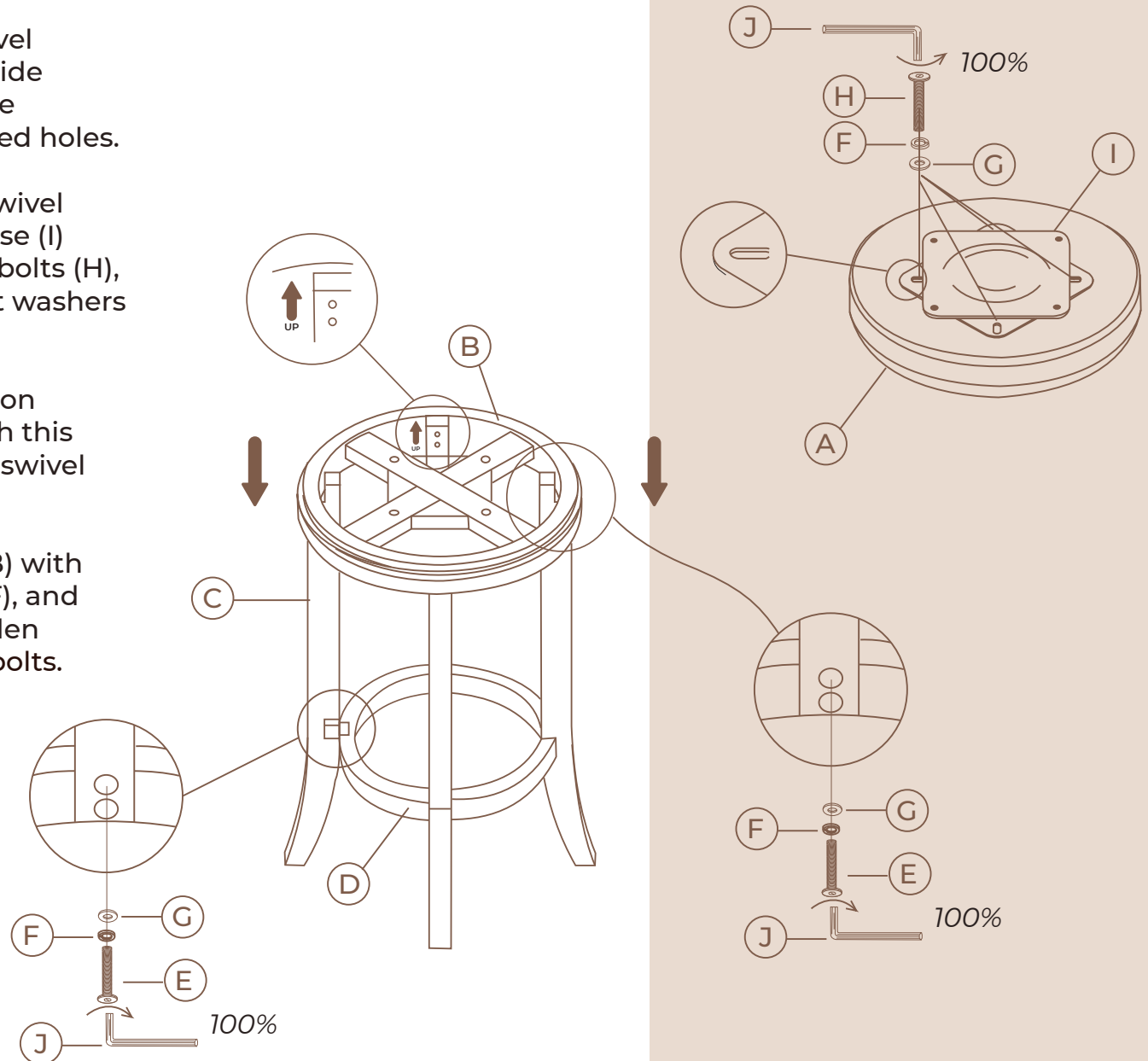

ASSEMBLY

STEP 3

Insert legs (C) into the seat frame (B). Attach legs with bolts (E), lock washers (F), and flat washers (G) using Allen key (J). Do not fully tighten all bolts.

Turn stool upright and place on flat, level surface. Ensure the legs are aligned and seat is level, then fully tighten all bolts from Steps 1 and 3.

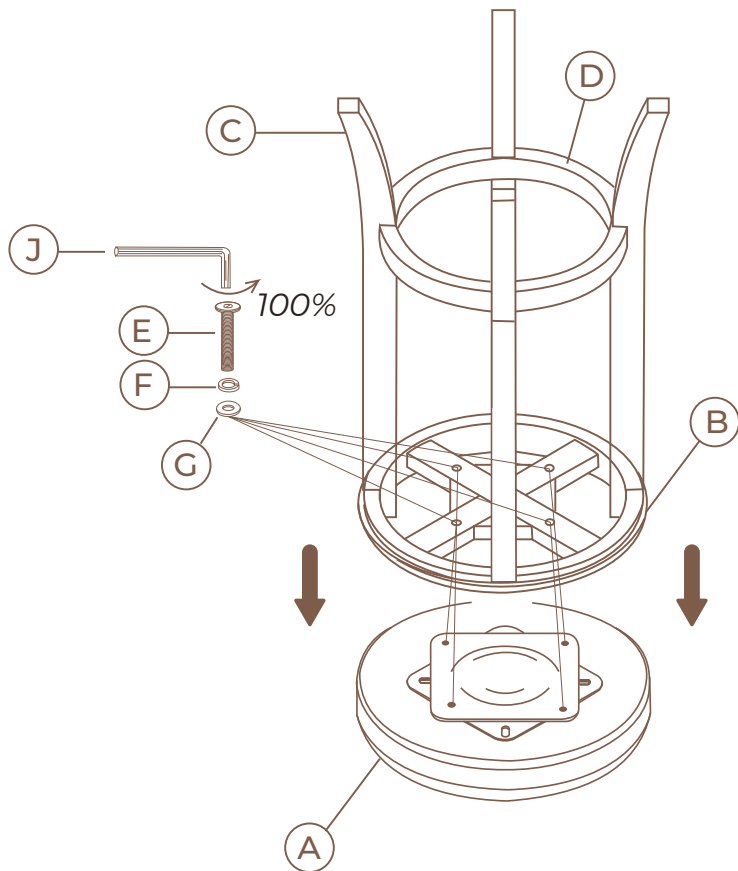

STEP 4: Felt Pad Application (optional)

1. Wipe any dust from the surface for best adhesion
2. Gently peel the felt pad from the paper
3. Firmly apply felt pad to the bottom

