

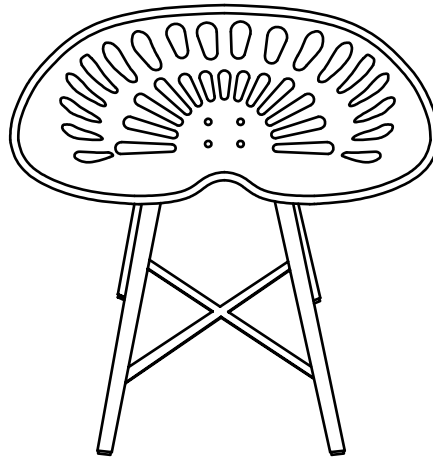



Assembly Instructions

TRACTOR SEAT FIRESIDE BENCH

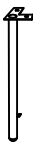

Thank you for purchasing a Forge Company product. This product has been designed for easy assembly and is constructed for durability. Please take the time to read and follow the assembly instructions carefully. If a part or hardware is missing or you have any difficulties in assembling this product, please contact us.

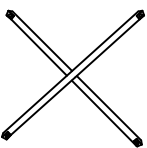
| NO | PARTS | DESCRIPTION | QTY | NO | PARTS | DESCRIPTION | QTY |
|----|---|-------------|-----|----|--|-------------------------|------|
| A |  | SEAT | 1PC | D |  | BUTTON HEAD BOLT 6X12MM | 12PC |
| B |  | LEG | 4PC | E |  | ALLEN KEY 4MM | 1PC |
| C |  | CROSS PIPE | 1PC | F |  | LEVELLER 6X12X19MM | 1PC |

Assembly Instructions

TRACTOR SEAT FIRESIDE BENCH

STEP 1

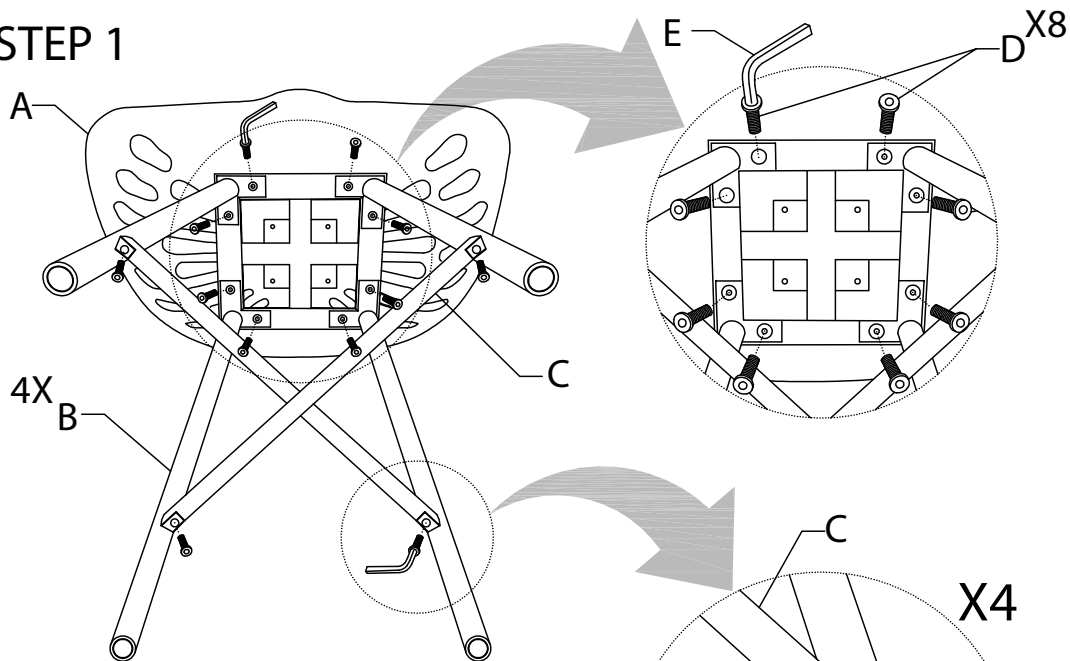

STEP 2

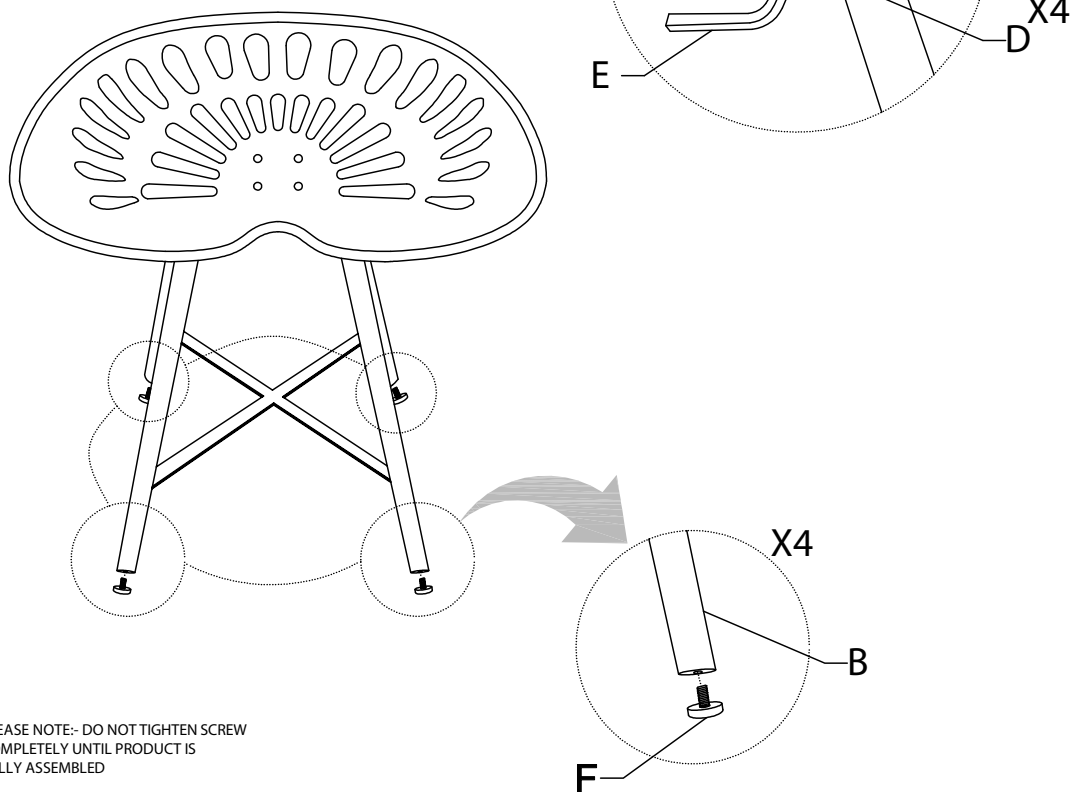

PLEASE NOTE:- DO NOT TIGHTEN SCREW COMPLETELY UNTIL PRODUCT IS FULLY ASSEMBLED