



















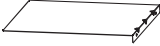





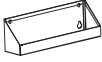

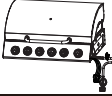





















No.	#	QTY / CANT. / QTÉ	Description / Descripción / Description	Image / Imagen / Image
1	EJDB17H5B -RGC	1	Bottom shelf Estante inferior Etagere inferieure	
2	AJQPGDZ01	1	Screw bushing Buje del perno de fijación de la bombona Douille de vis	
3	07-QPG-05-SI	1	LP cylinder screw Perno de fijación de la bombona Vis de bouteille de gaz	
4	05-WXL-20	4	Caster Rueda Roulette	
5	EJCB03	1	Side panel (L) Panel lateral (I) Panneau latéral (G)	
6	EJCB04-RGC	1	Side panel (R) Panel lateral (D) Panneau latéral (D)	
7	EJHB025B	1	Rear panel Panel trasero Panneau arrière	
8	EJGDSJB01	2	Triangle support plate Placa de soporte triangular Plaque de support triangulaire	
9	Z-ZH300303	1	LP cylinder barrier bar Barra de seguridad para la bombona de gas Barre de barrière de bouteille de gaz	
10	EJHL05H5B	1	Cart front beam Barra frontal del carro Poutre avant du chariot	
11	EJQPGRB01-DS1	1	Thermal baffle Deflector térmico Panneau isolant	
12	EJLTGDBL02	1	Grease tray bracket (L) Fijación de Bandeja de recojida de grasa (I) Support du Lèchefrite (G)	
13	EJLTGDBR02	1	Grease tray bracket (R) Fijación de Bandeja de recojida de grasa (D) Support du Lèchefrite (D)	
14	EJSM045B -RGC (L)	1	Cabinet door (L) Puerta del armario (I) Porte d'armoire (G)	
15	EJSM045B -RGC (R)	1	Cabinet door (R) Puerta del armario (D) Porte d'armoire (D)	

No.	#	QTY / CANT. / QTÉ	Description / Descripción / Description	Image / Imagen / Image
16	EJMGDPL01	1	Beam connector (L) Unión de la barra (I) Connecteur de faisceau (G)	
17	EJMGDPR01	1	Beam connector (R) Unión de la barra (D) Connecteur de faisceau (D)	
18	EJBJGL01	1	Basket Cesta Panier	
19	04-GBS-2-01-2 00-PG	2	Door handle Tirador de la puerta Poignée de la porte	
20	04-BSZ-03-BK	4	Handle sleeve Base de encastre del tirador Manche de poignée	
21		1	Main body Cuerpo principal Corps principal	
22	ET30-L	1	Side shelf Bandeja lateral Étagère latérale	
23	EB30-R	1	Side burner shelf Base del quemador lateral Étagère du bruleur d'appoint	
24	06-XNZ-6-01	1	Knob base Base de mando de regulación de llama Base du bouton	
25	06-XNL-6-14-BK- RGC	1	Knob Mando de regulación de llama Bouton	
26	01-LTL-4-23-245 -SS4	1	Side burner Quemador lateral Bruleur d'appoint	
27	ELJYP035B-RGC -DS2	1	Crease tray Bandeja de recogida de grasa Lêchefrite	
28	07-GGL-38-SI	1	Grease cup holder Soporte de la taza de grasa Graisser le porte-gobelet	
29	ELYB02-LS4	1	Grease cup Depósito de recogida de grasa Bac à graisse	

No.	#	QTY / CANT. / QTÉ	Description / Descripción / Description	Image / Imagen / Image
30	EJLTGDPL-RGC	1	Main body cart joint (L) Junta del carro del cuerpo principal (I) Joint de chariot du corps principal (G)	
31	EJLTGDPR-RGC	1	Main body cart joint (R) Junta del carro del cuerpo principal (D) Joint de chariot du corps principal (D)	
32	ELFHB04H-RGC -SS4	1	Flame tamer (big) Regulador de llama (grande) Gros atténuateur de flamme	
33	ELFHB05-RGC	5	Flame tamer Regulador de llama Atténuateur de flamme	
34	03-ZTW-E-02 -TC4	1	Cooking grate Rejilla para asar Grille de cuisson	
35	03-ZTW-E-01 -TC4	2	Cooking grate (big) Rejilla para asar (grande) Gros grille de cuisson	
36	ELBWW015B -SS4	1	Warming rack Rejilla para calentar Grille de réchauffement	
37	06-WDJ-3-03	1	Thermometer Termómetro Thermomètre	

No.	#	Image / Imagen / Image	No.	#	Image / Imagen / Image
A	M5×10	 x56	H	Stud with nut Espárrago con tuerca integrada Goujon avec écrou	 x4
B	Washer Arandela Rondelle	 x4	I	Washer Arandela Rondelle	 x1
C	M4×10	 x4	J	M5	 x3
D	M5×12	 x10	K	M4×8	 x6
E	Magnet Imán Aimant	 x1	L	Washer Arandela Rondelle	 x8
F	M6×15	 x22	M	M5×12	 x3
G	M5×5	 x3			

TOOLS REQUIRED / HERRAMIENTAS REQUERIDAS / OUTILS REQUIS

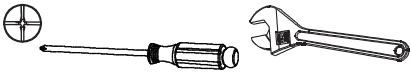
Phillips screwdriver Destornillador phillips Tournevis phillips	Wrench Llave Clé	
-----------------------------------------------------------------------	------------------------	--------------------------------------------------------------------------------------

Before beginning assembly, make sure all parts are present. If any parts are missing or damaged, do not attempt to assemble the products. Contact customer service for replacement parts via telephone or email.

- Tools needed (not included): Phillips screwdriver and wrench
- Approximate assembly time: 60 minutes
- Note: 1. The right and left sides of the grill are designed as if you are facing the front of the grill.
2. Model shown for illustration purpose only, specific please in kind prevail.

Antes de comenzar el montaje, asegúrese de que todas las piezas estén presentes. Si falta alguna pieza o está dañada, no intente ensamblar los productos. Póngase en contacto con el servicio de atención al cliente para obtener piezas de repuesto por teléfono o correo electrónico.

- Herramienta necesaria (no incluido): Destornillador phillips y llave
- Tiempo aproximado de ensamblaje: 60 minutos
- Nota: 1. Los lados derecho e izquierdo de la parrilla están diseñados como si estuvieras frente a la parte delantera de la parrilla.
2. El modelo que se muestra es sólo para fines ilustrativos, prevalecen los específicos en especie.

Avant de commencer l'assemblage, assurez-vous que toutes les pièces sont présentes. Si des pièces sont manquantes ou endommagées, n'essayez pas d'assembler les produits. Contactez le service de clientèle pour les pièces de rechange par téléphone ou par e-mail.

- Outils nécessaires (non inclus): Tournevis phillips et clé
- Temps nécessaire pour l'assemblage: 60 minutes
- Remarque: 1. Les côtés droit et gauche du gril sont conçus comme si vous faisiez face à l'avant du gril.
2. Le modèle est présenté à des fins d'illustration uniquement, spécifiques en nature prévalent.

1 F   x2

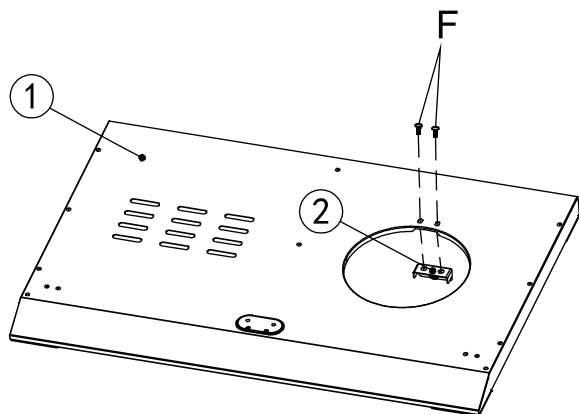

2

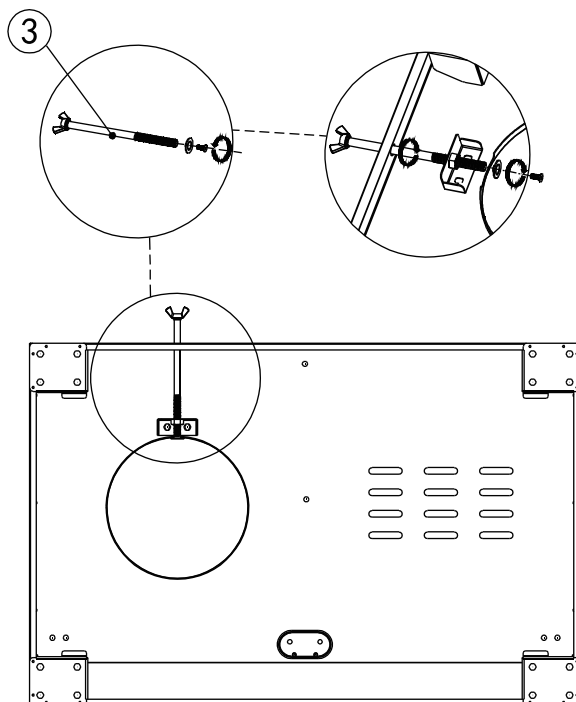

3 F   x16

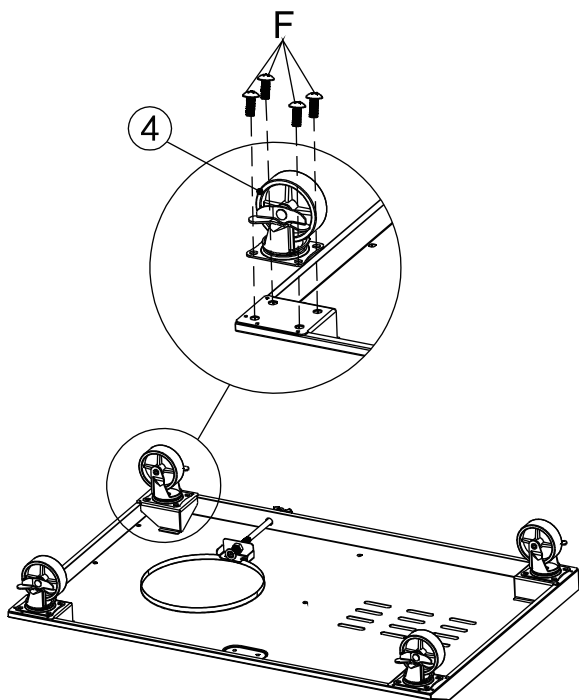

4 A   x4

- Do not secure the bolts until step 6.
- No apretar las tornillos hasta el paso 6.
- Ne pas fixez les boulons avant l'étape 6.

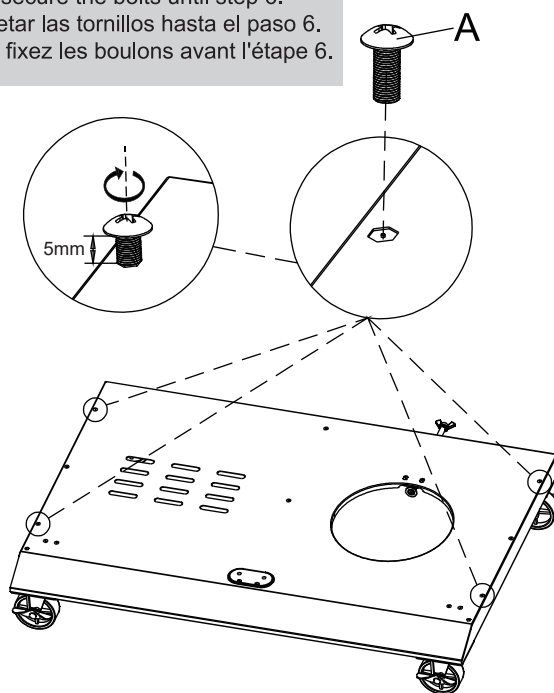

5

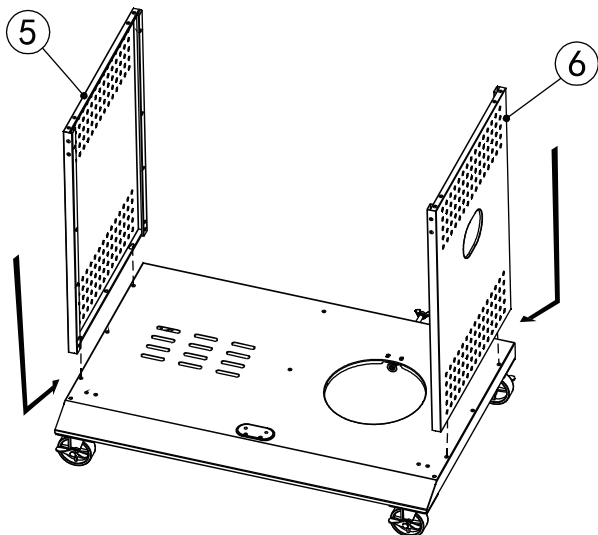

6

A  ⊕ ×2

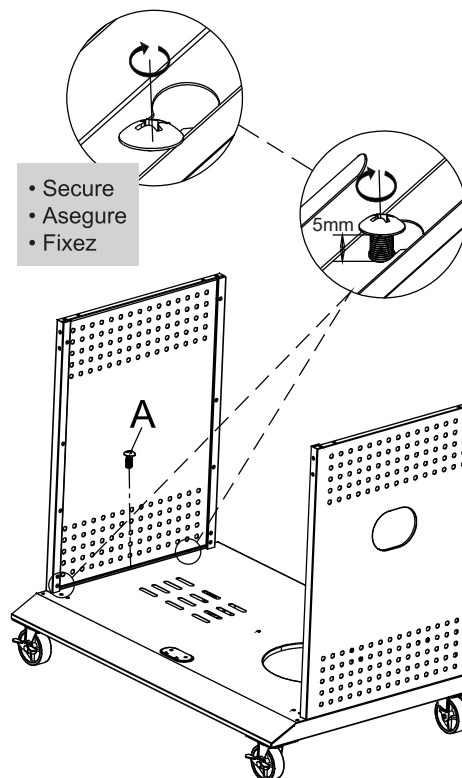

7

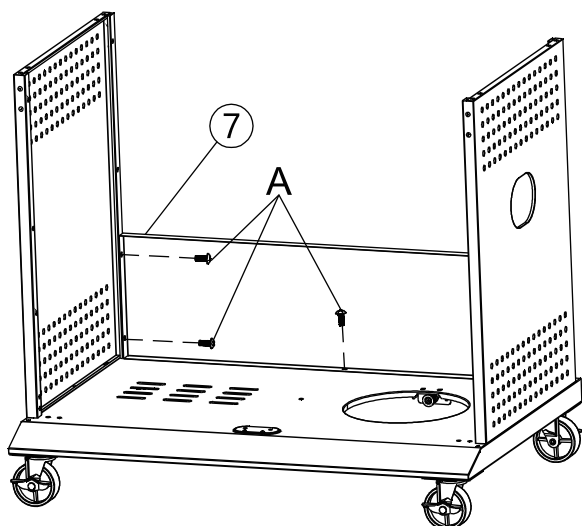

A  ⊕ ×5





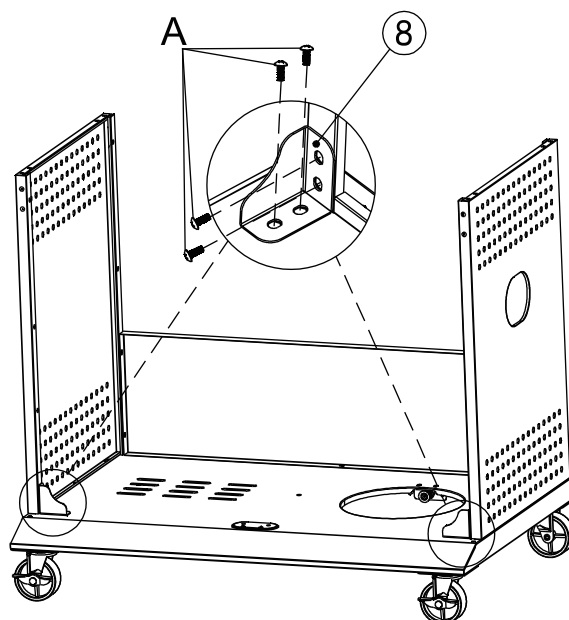

8

A  ⊕ ×8

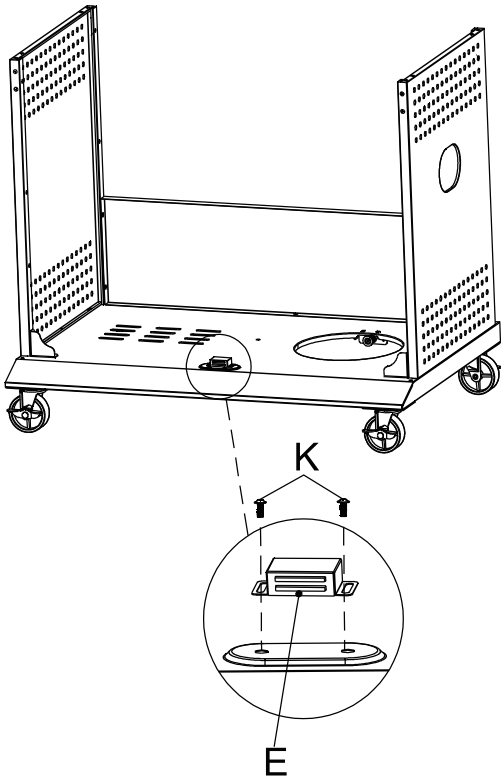



- 9** K  x2 E  x1

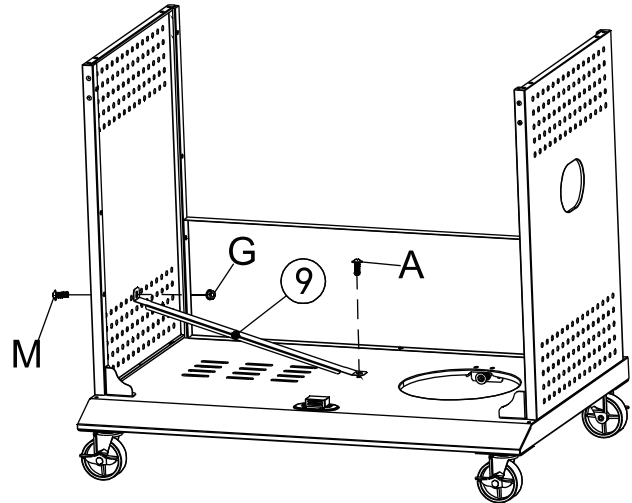

- 10** A  x1 G  x1
M  x1



- 11** A  x2 D  x6

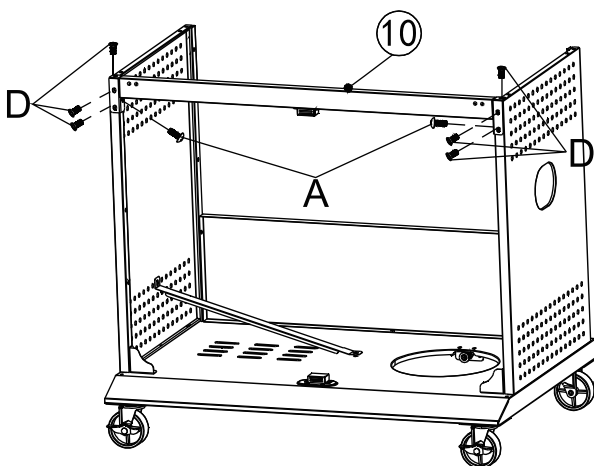

- 12** A  x2

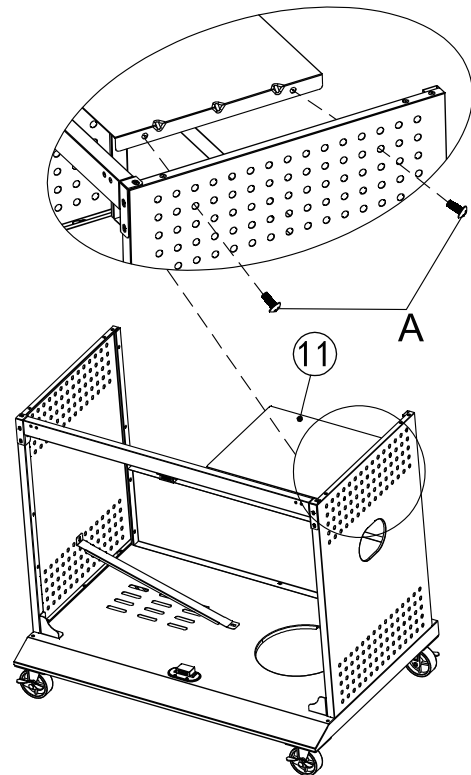

13 D  x4

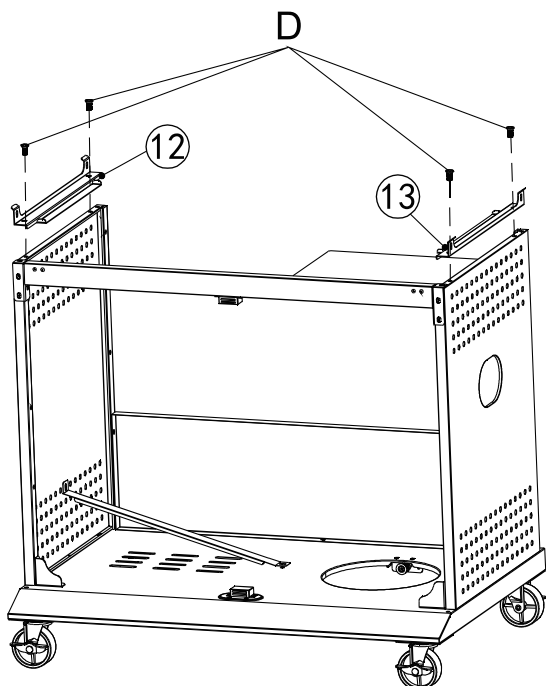

14 H  x4

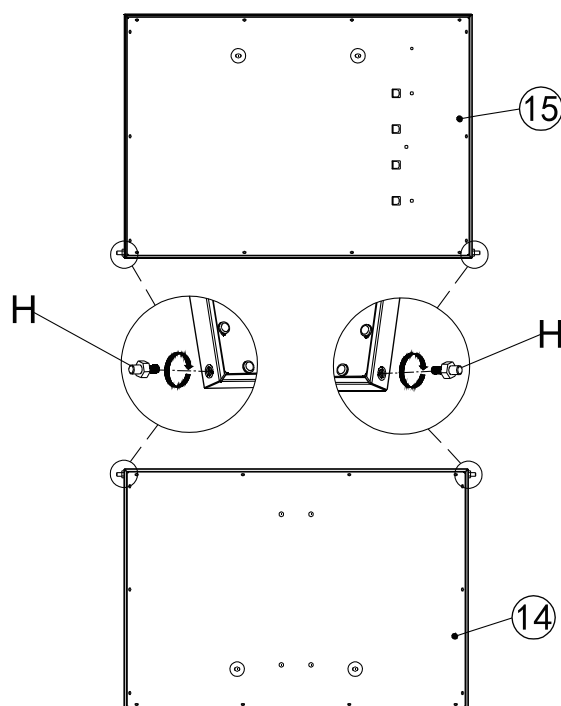

15

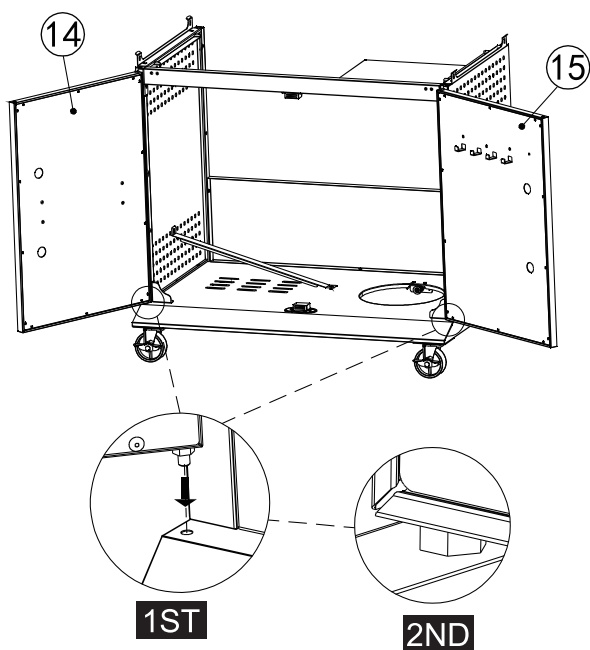

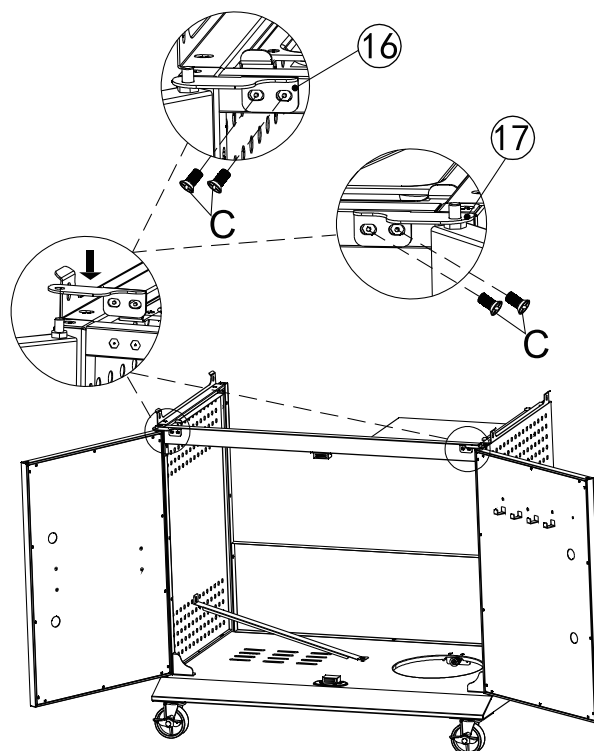

16 C  x4



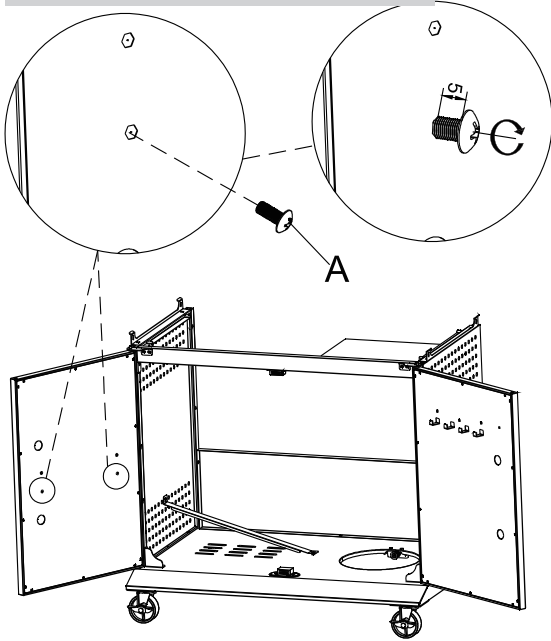

17 A   x2

- Do not secure the bolts until step 18.
- No apretar las tornillos hasta el paso 18.
- Ne pas fixez les boulons avant l'étape 18.

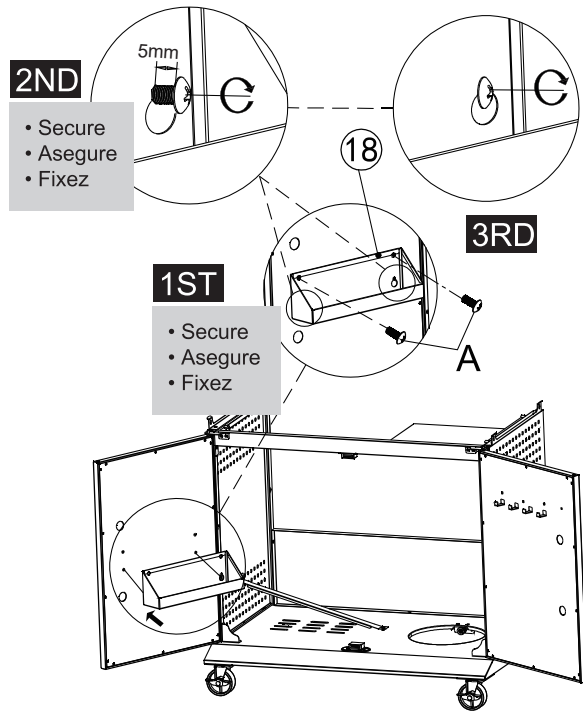

18 A   x2



19 B  x4 F  x4

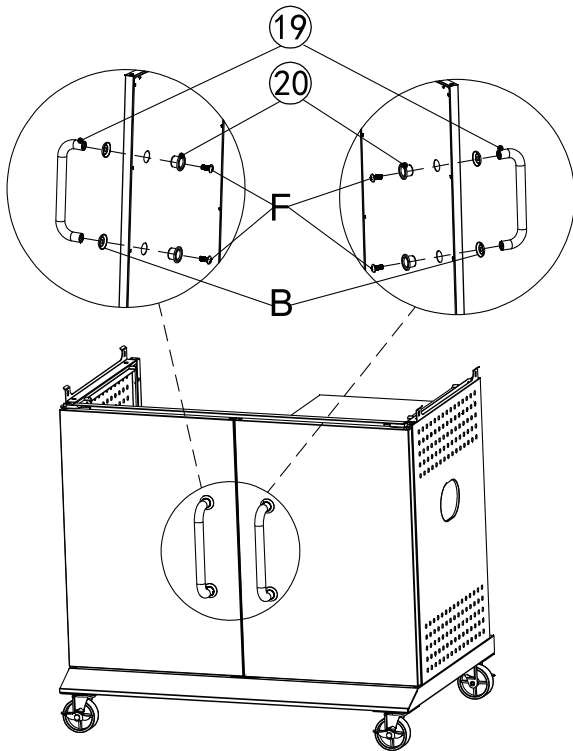

20 A  x4

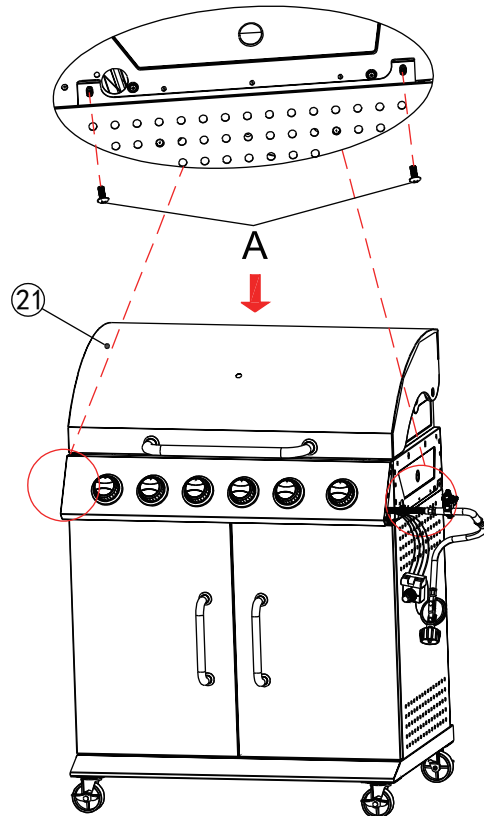

21 A   x5

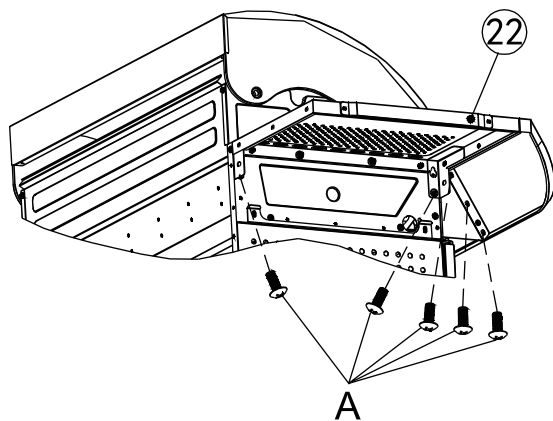



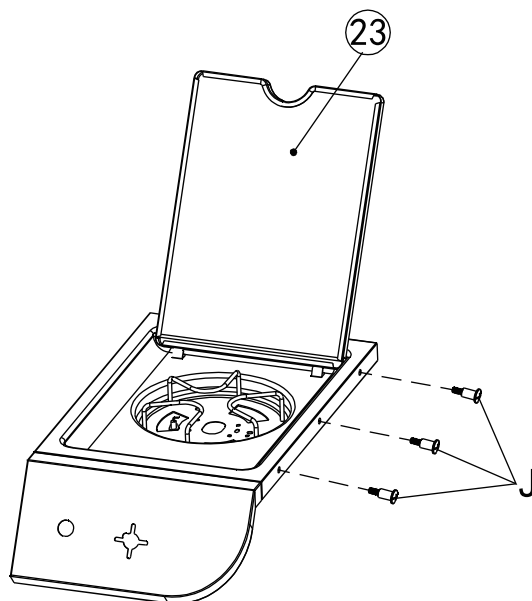

22 J   x3

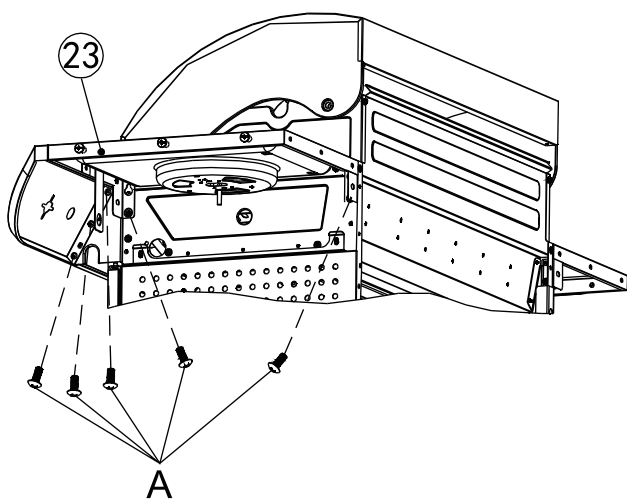

23 A   x5



24 A   x8 L   x8

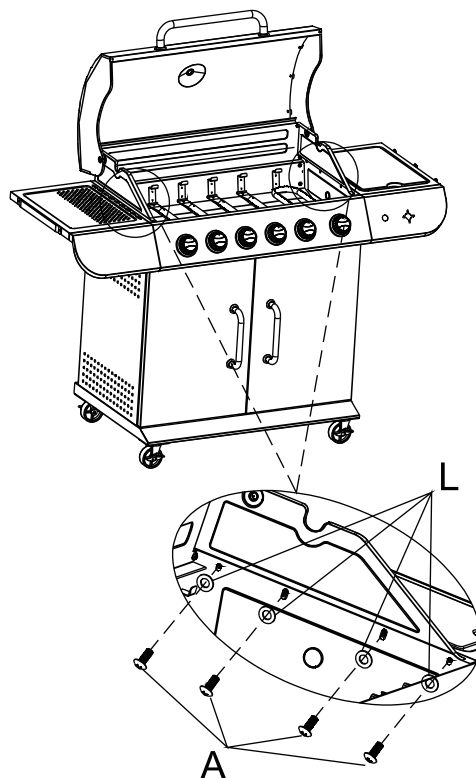

25

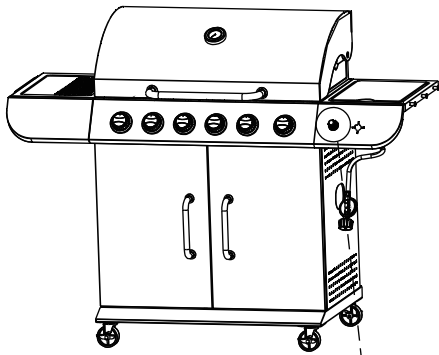

- AA battery not included.
- Pila AA no incluida.
- Pile AA non incluse.

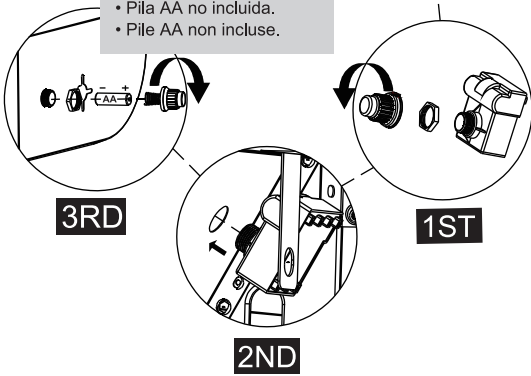

26

K  ×2

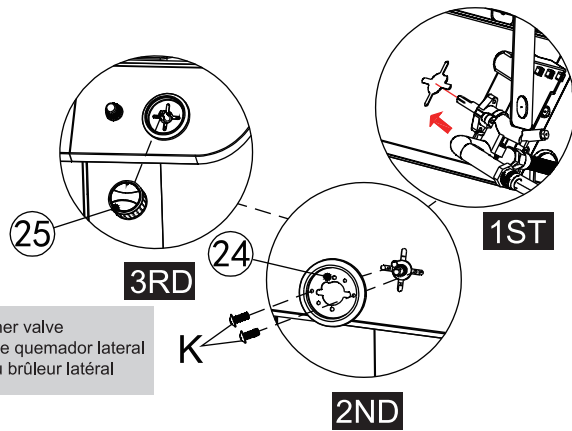
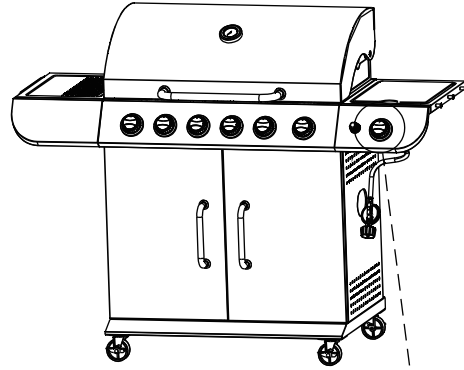

- Side burner valve
- Válvula de quemador lateral
- Vanne du brûleur latéral

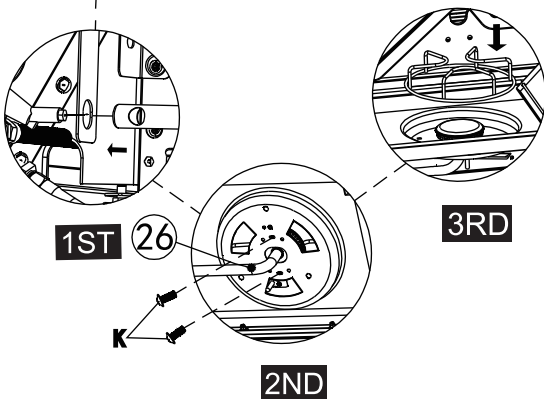
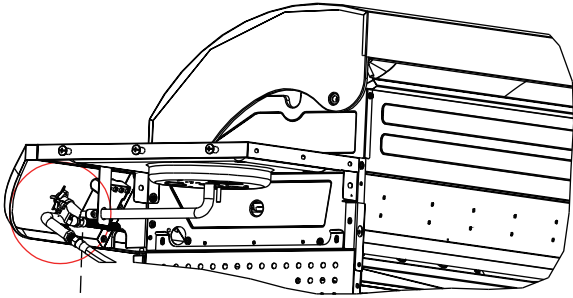

27

K  ×2

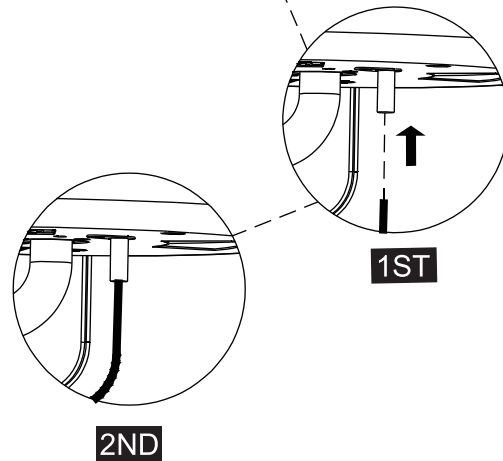
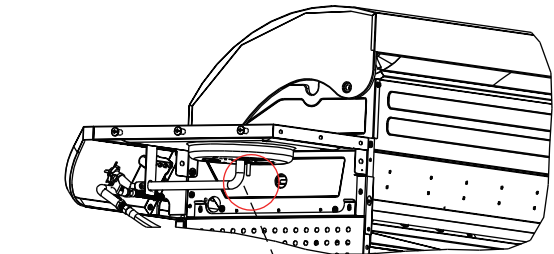

28



29 G  x2 M  x2

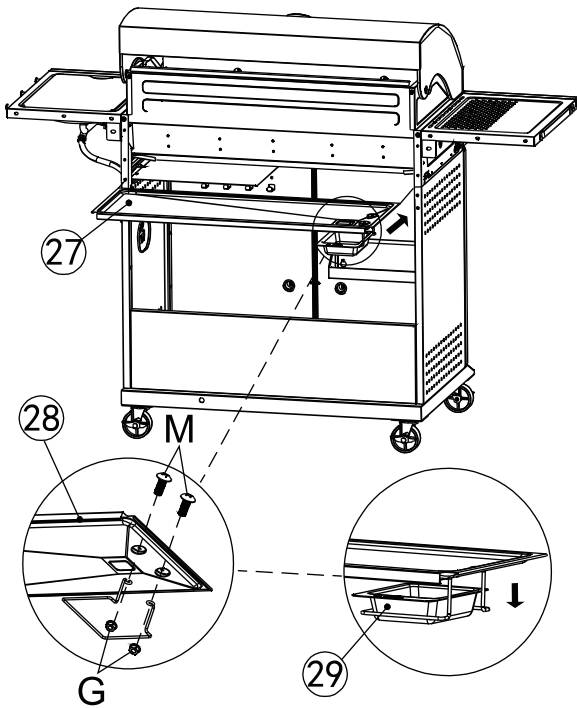

30 A  x6

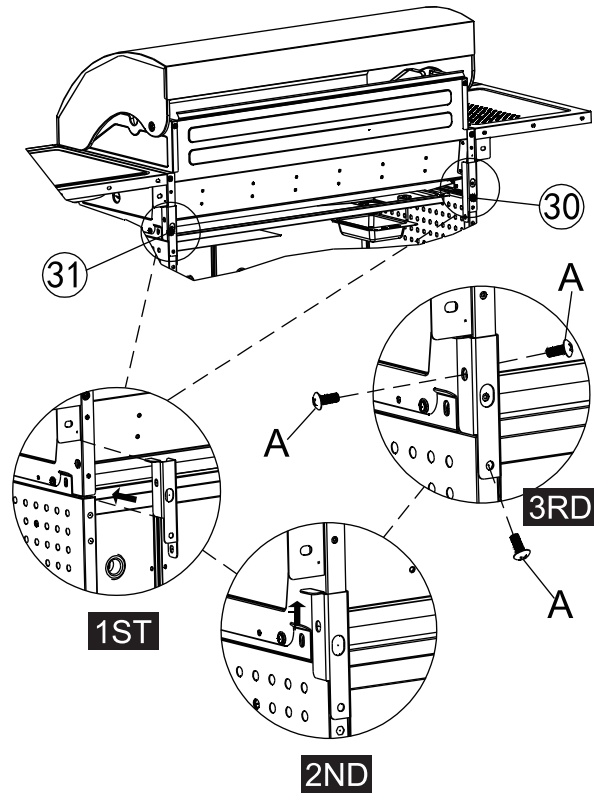

31

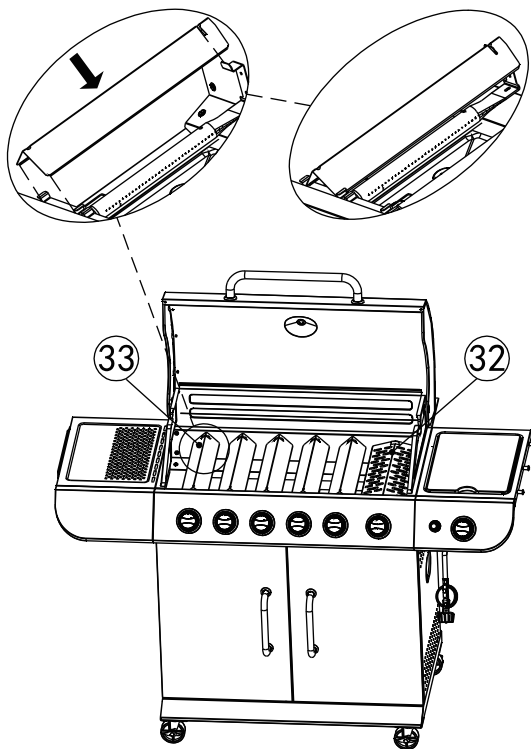

32

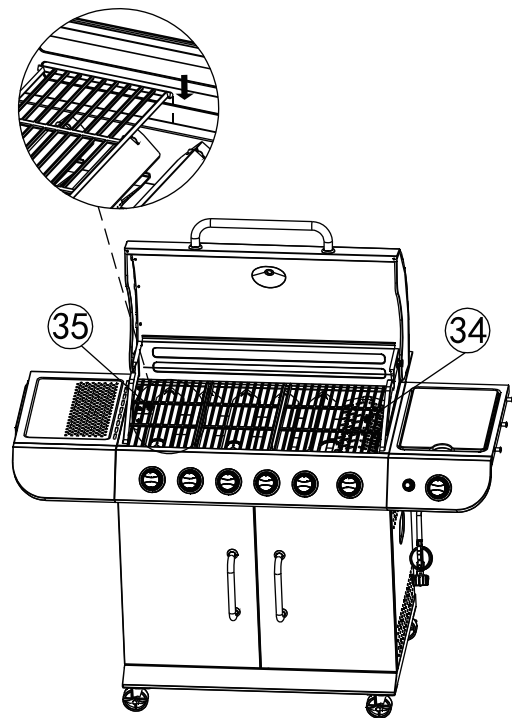

33

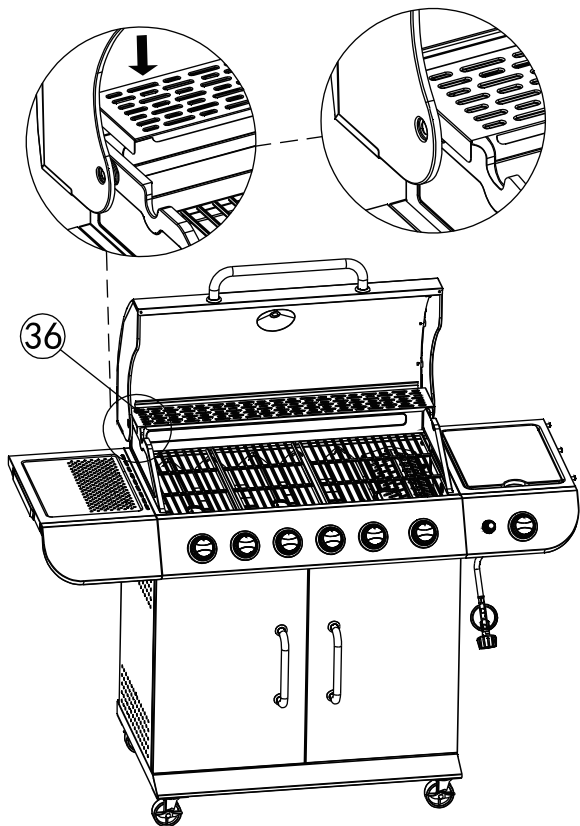

34

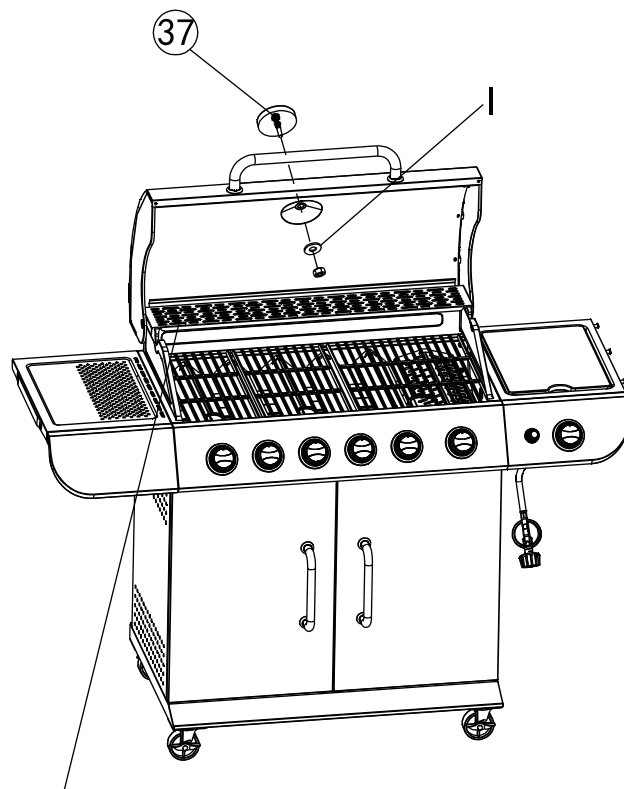
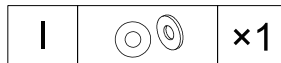

- The warming rack is covered with a protective film, please remove it before use.
- La rejilla calefactora está cubierta con una película, retírela antes de hacer el primer uso.
- Le Grille de réchauffement est recouvert d'un film protecteur, veuillez l'enlever avant utilisation.

**Thank You
For Choosing Us.**

**Any Problem!
We Can Help!**

**Customer
Service**

1-800-618-6798

Monday to Friday (8:30 am - 5:00 pm EST)

service@royalgourmetusa.com