







CARE AND MAINTENANCE

Wipe clean with a soft, dry cloth. Test the cleaning method on a hidden area before using them over the entire area.

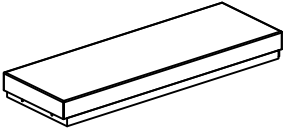
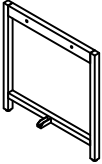
NOTICE

- * Please make sure that you have all parts indicated before you begin assembly of this item.
- * This item should be assembled on a soft surface to prevent scratching the finished product during assembly.
- * This item may require periodic tightening.
- * Do not tighten bolts until completely assembled.

Part List and Hardware List

PIECE	DESCRIPTION	PICTURE	QUANTITY
A	Seat Cushion		1x
B	Side Frame		2x
C	Connecting Bar		1x
H1	Allen Bolt	 1/4"x 5/8"	4x
H2	Allen Bolt	 1/4"x 1-1/4"	4x
H3	Flat Washer	 $\phi 16*1.0$	4x
H4	Spring Washer	 1/4"	4x
H5	Allen Key	 M4	1x

Product Dimensions: 47-1/4"Wx16"Dx19-1/2"H

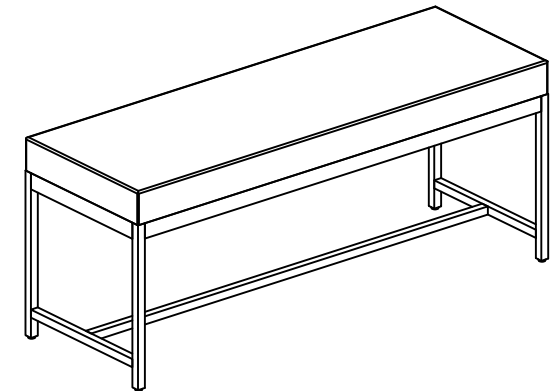

Weight capacity : 550 lbs
WARNING:DO NOT STAND ON THE BENCH

PREPARATION

Before beginning assembly of product, make sure all parts are present. Compare parts with package contents list and hardware contents list. If any part is missing or damaged, do not attempt to assemble the product.

Estimated Assembly Time: 20 minutes.

Tools Required for Assembly (included): Allen Key

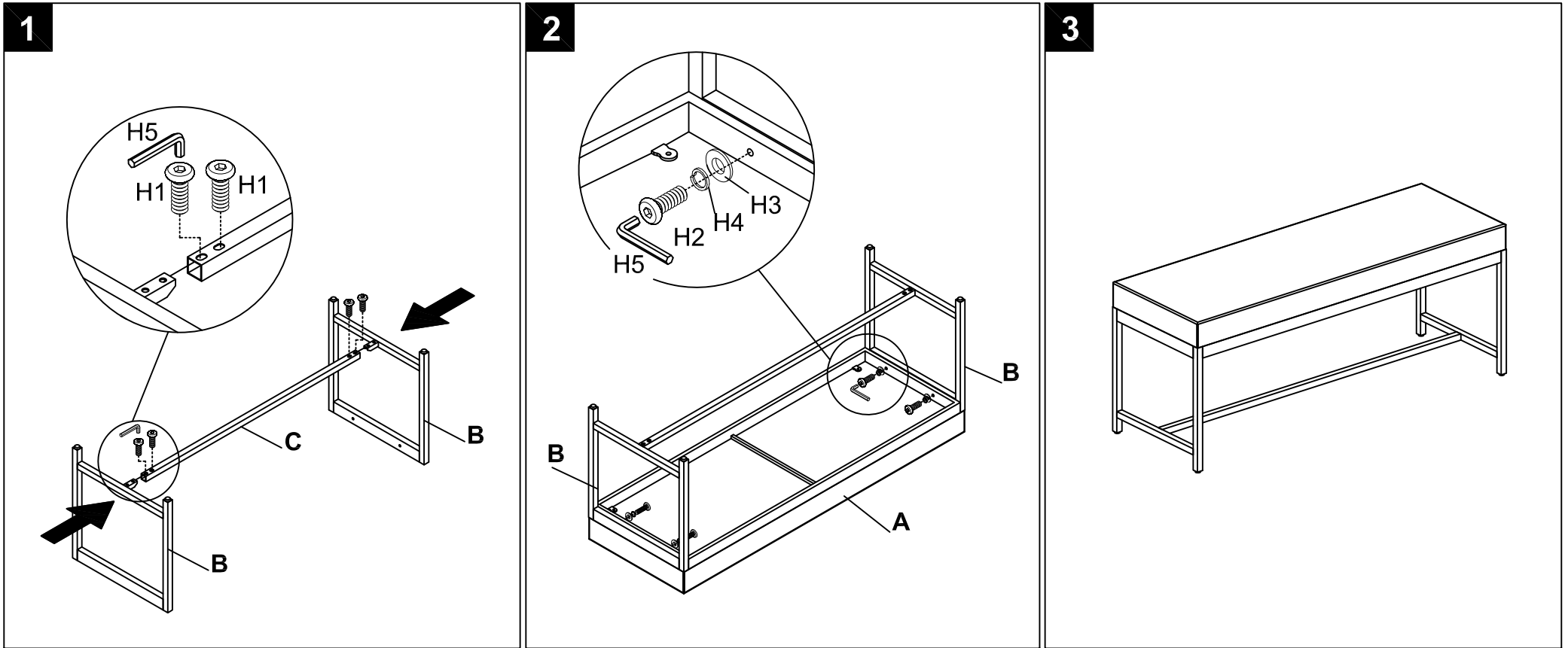

Step 1

The side of the side frame (B), which has a welded protrusion, should face inwards.

Insert the Connecting Bar (C) into to the protrusion of the 2*Side Frames (B), Use Allen key (H5) to lock with 4*Allen bolts (H1), Please reference image above.

Step 2

Attach the assembled metal base to the underside of seat cushion (A). Align the screw holes on seat cushion (A) with the threads on the metal base. Inset Allen bolts (H2) with the Spring Washer (H4) & Flat Washer (H3) into the holes and tighten with Allen key (H5). Please reference image above.

Step 3

Stand upright up the assembled product, assembly is completed.