

**STEP 13**

D UPPER TOP PANEL 1 PC

F SHELF PANEL 1 PC

6 LONG POLE 1 PC

7 SHORT POLE 1 PC

UNFINISHED SURFACE

**STEP 15**

ASSEMBLED UNIT

ASSEMBLED UNIT

TURN 180°

TOOL REQUIRED

**STEP 14**

ASSEMBLED UNIT

E BOTTOM PANEL 1 PC

9 LEG 1 PC

UNFINISHED SURFACE

**STEP 16**

ASSEMBLED UNIT

1 LONG SCREW 4 PCS

TOOL REQUIRED

# Assembly Instruction

Computer Desk

**00:30**

Approx. 30 minutes

**Recomm. 1 Person**

**Tool Required**

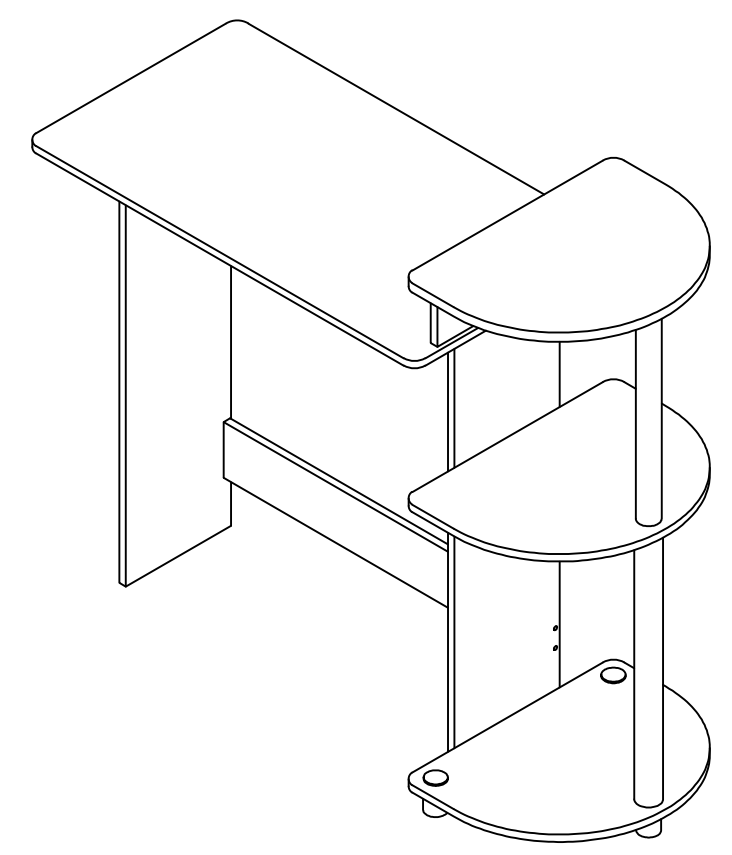

## Recommended Maximum Weight

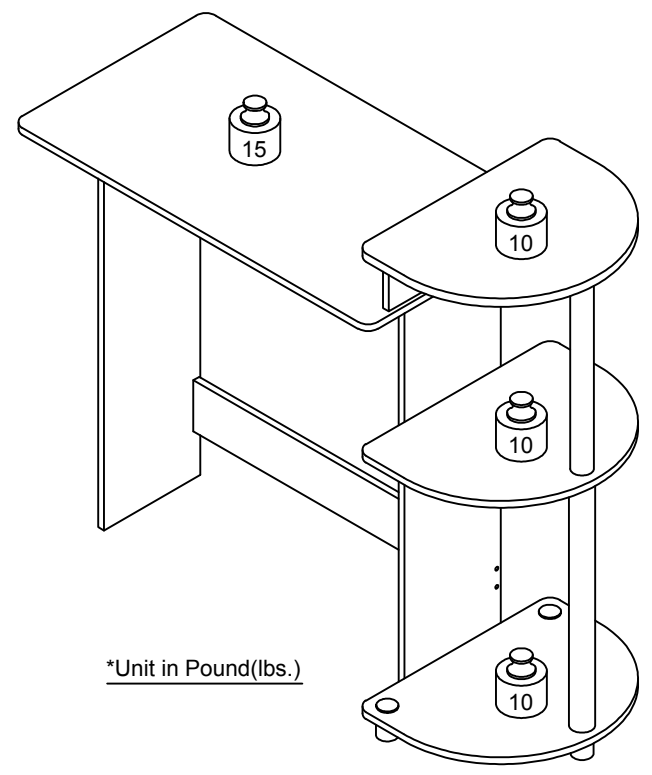

\*Unit in Pound(lbs.)

**WARNING:**

>This unit has been designed to support the maximum loads shown. Exceeding these load limits could cause sagging, instability, product collapse, and/or serious injury.

>DO NOT allow children to climb on unit.

>Put heavier items on lower shelves.

# EXPLODED VIEW

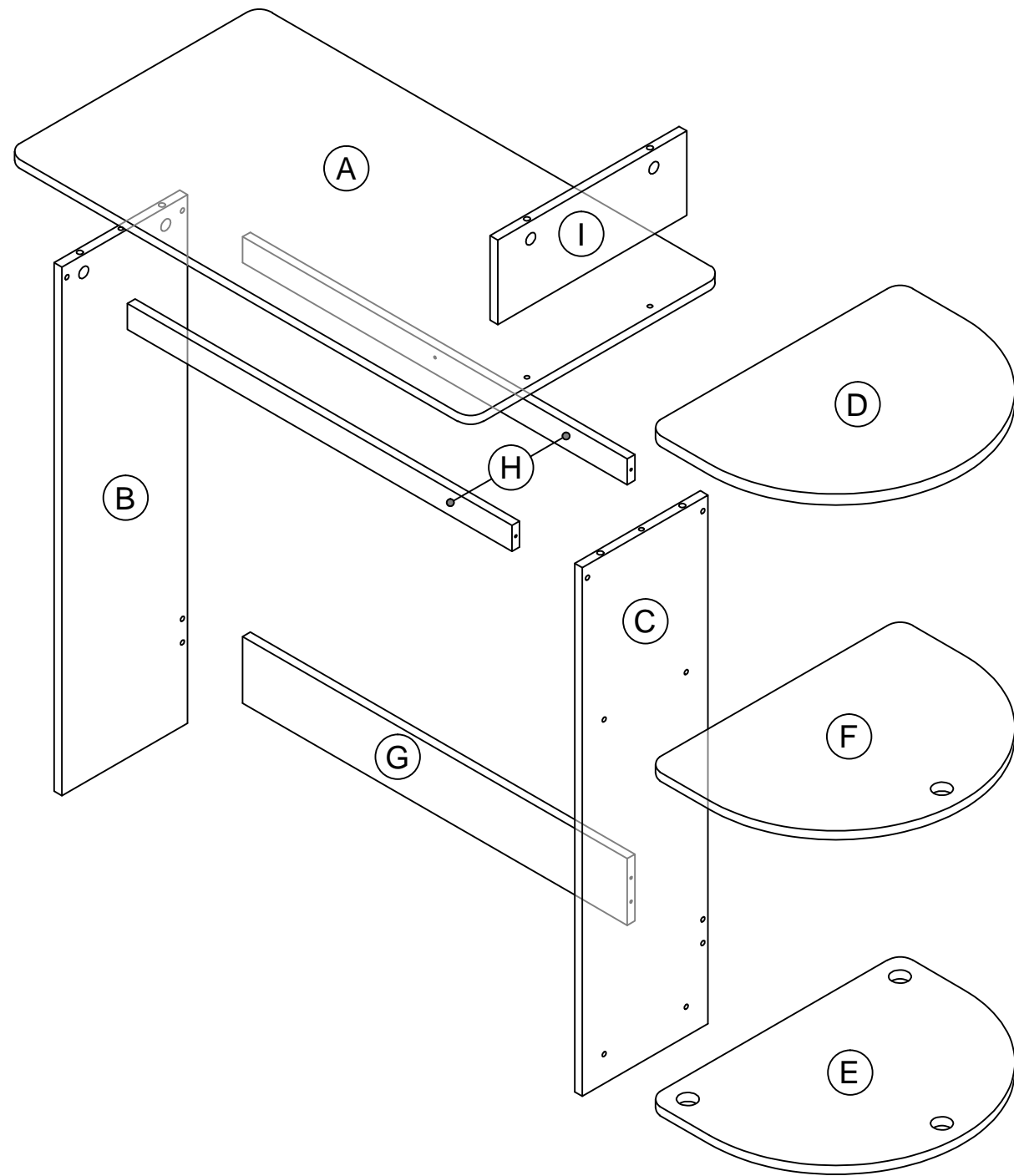

## USEFUL HINTS BEFORE YOU START:

1. Read each step carefully before starting.
2. It is important that each step is performed in correct order to avoid difficulties.
3. Identify, soft and count the parts before assembly.
4. Assemble your furniture on packaging cardboard to prevent scratch or damage.
5. Clean the product with mild cleanser using soft damped cloth. Do not use harsh or abrasive cleanser.
6. Using incompatible hardware might cause damage to product.

## STEP 11

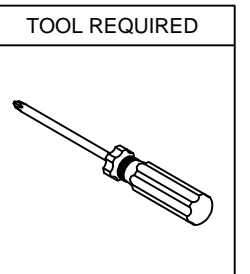
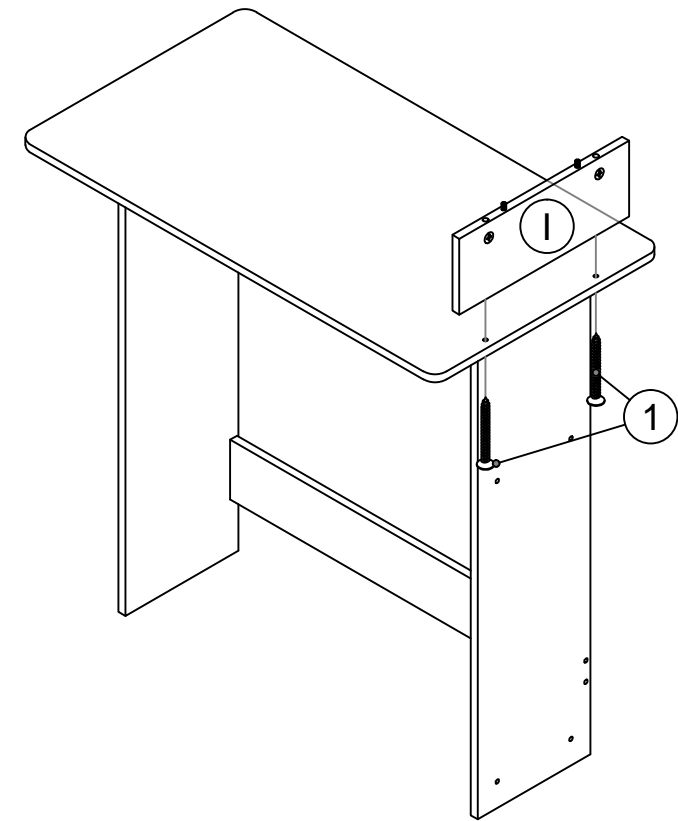
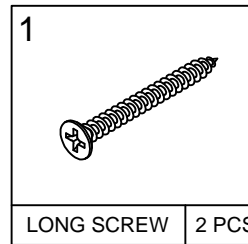
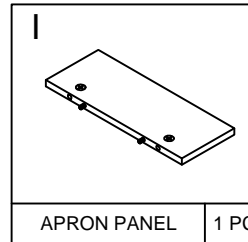
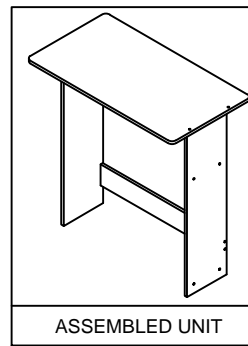

## STEP 12

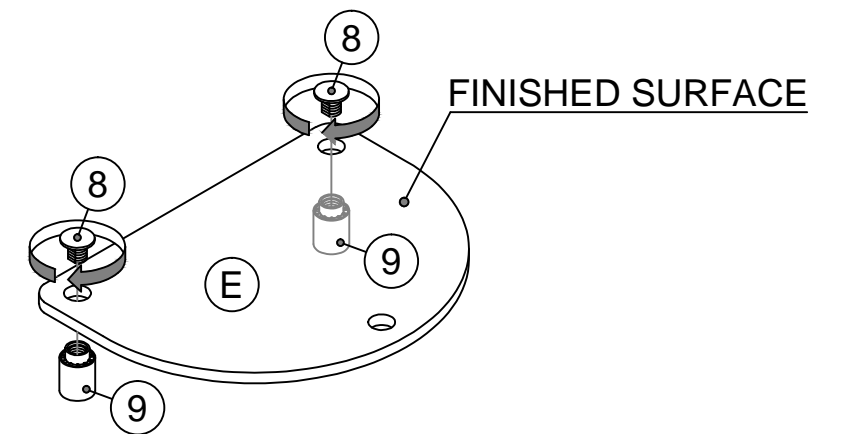
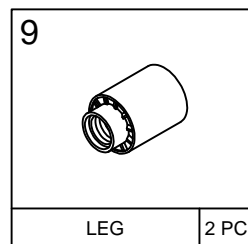
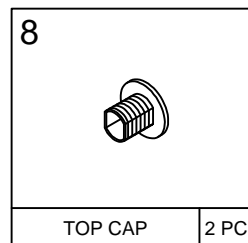
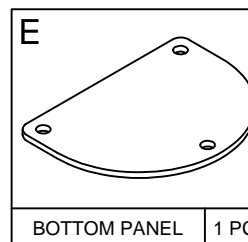

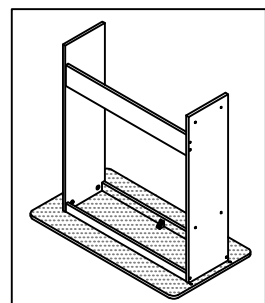

ASSEMBLED UNIT

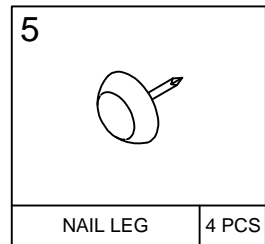

NAIL LEG 4 PCS

### STEP 9

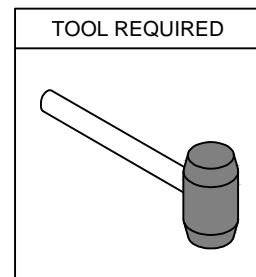
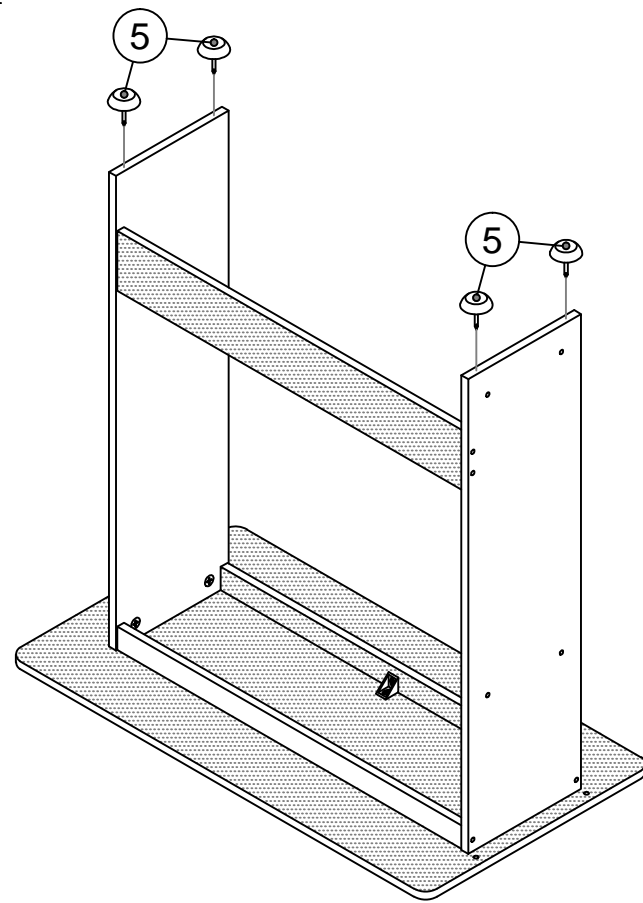

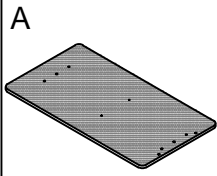
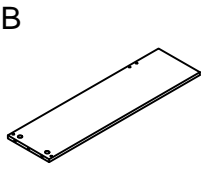
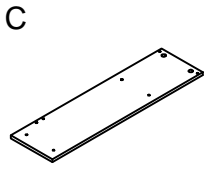
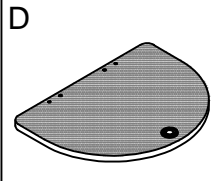
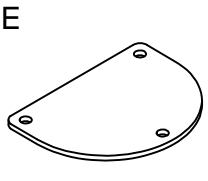
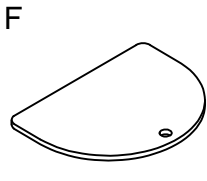
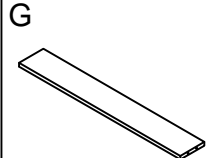
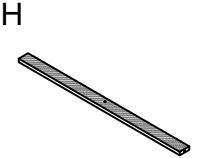
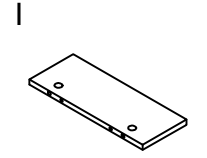

TOOL REQUIRED

### PARTS LIST

<b>A</b>  TOP PANEL 1 PC	<b>B</b>  LEFT SIDE PANEL 1 PC	<b>C</b>  RIGHT SIDE PANEL 1 PC
<b>D</b>  UPPER TOP PANEL 1 PC	<b>E</b>  BOTTOM PANEL 1 PC	<b>F</b>  SHELF PANEL 1 PC
<b>G</b>  BOTTOM CROSS BAR 1 PC	<b>H</b>  SKIRT PANEL 2 PCS	<b>I</b>  APRON PANEL 1 PC

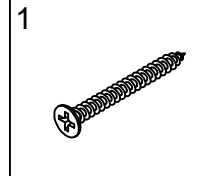
### HARDWARE LIST

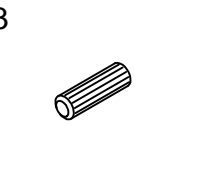
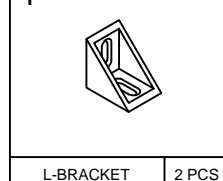
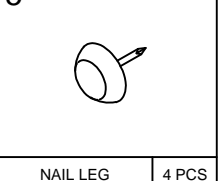
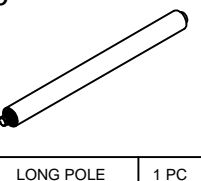
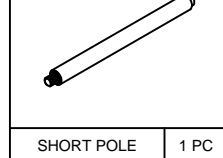
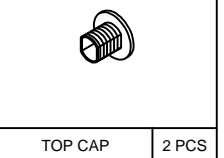
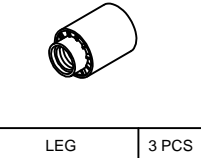
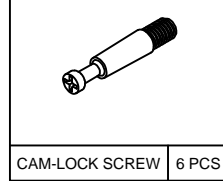
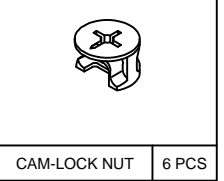
<b>1</b>  LONG SCREW 14 PCS	<b>2</b>  SHORT SCREW 4 PCS	<b>3</b>  DOWEL 4 PCS
<b>4</b>  L-BRACKET 2 PCS	<b>5</b>  NAIL LEG 4 PCS	<b>6</b>  LONG POLE 1 PC
<b>7</b>  SHORT POLE 1 PC	<b>8</b>  TOP CAP 2 PCS	<b>9</b>  LEG 3 PCS
<b>10</b>  CAM-LOCK SCREW 6 PCS	<b>11</b>  CAM-LOCK NUT 6 PCS	

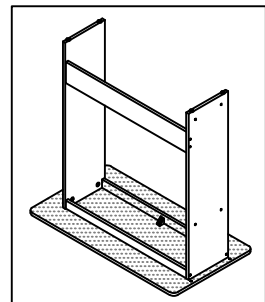

ASSEMBLED UNIT

### STEP 10

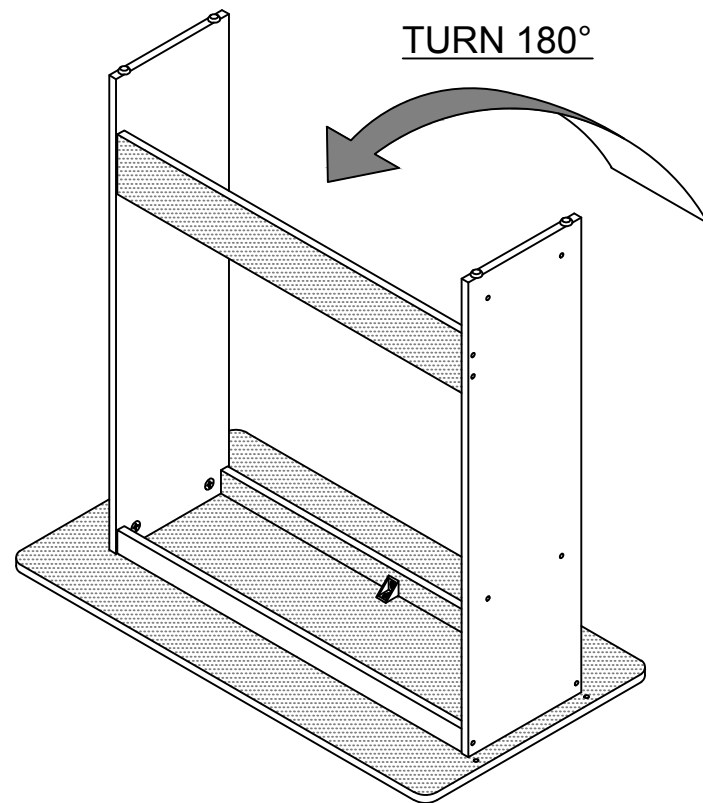

TURN 180°

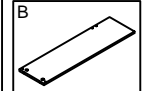
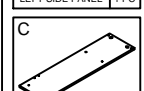
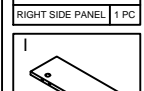
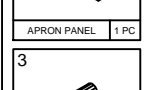
<b>B</b>  LEFT SIDE PANEL 1 PC
<b>C</b>  RIGHT SIDE PANEL 1 PC
<b>I</b>  APRON PANEL 1 PC
<b>3</b>  DOWEL 4 PCS

#### STEP 1

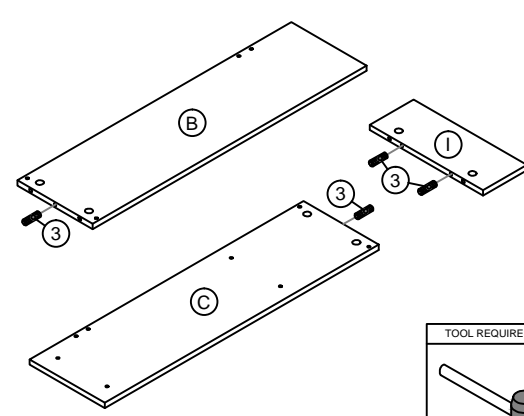

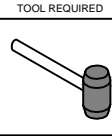

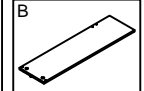
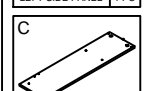
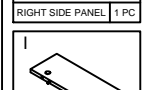
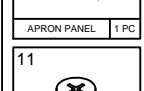
TOOL REQUIRED	
	

<b>B</b>  LEFT SIDE PANEL 1 PC
<b>C</b>  RIGHT SIDE PANEL 1 PC
<b>I</b>  APRON PANEL 1 PC
<b>11</b>  CAM-LOCK NUT 6 PCS

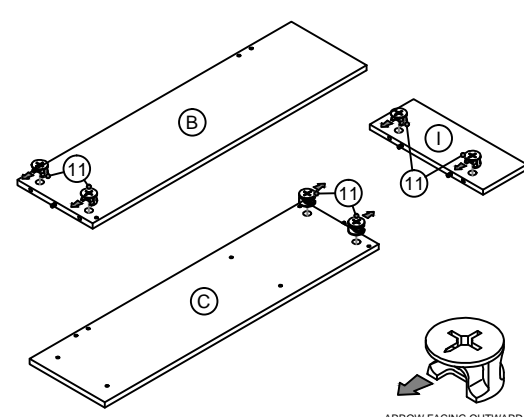
#### STEP 2

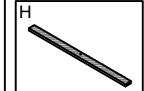

TOOL REQUIRED	
	

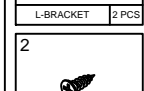
<b>H</b>  SKIRT PANEL 2 PCS
<b>4</b>  L-BRACKET 2 PCS
<b>2</b>  SHORT SCREW 2 PCS

#### STEP 3

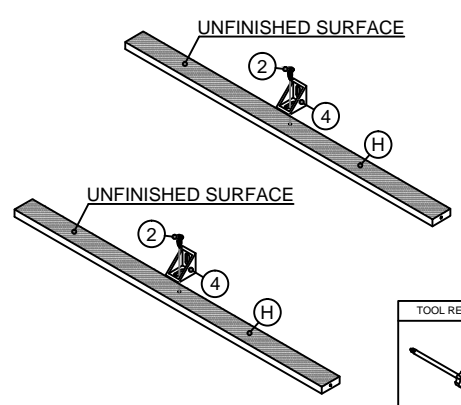

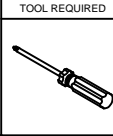
TOOL REQUIRED	
	

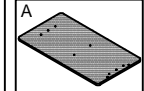
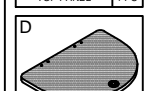
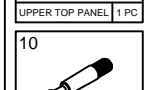
<b>A</b>  TOP PANEL 1 PC
<b>D</b>  UPPER TOP PANEL 1 PC
<b>10</b>  CAM-LOCK SCREW 6 PCS

#### STEP 4

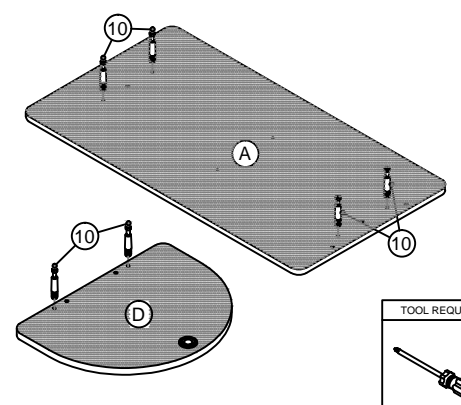

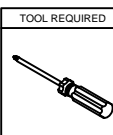
TOOL REQUIRED	
	

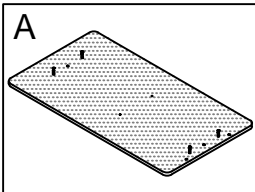

TOP PANEL 1 PC

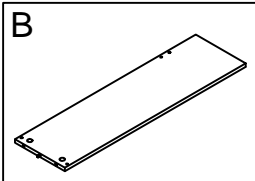

LEFT SIDE PANEL 1 PC

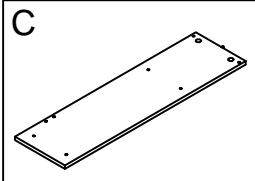

RIGHT SIDE PANEL 1 PC

### STEP 5

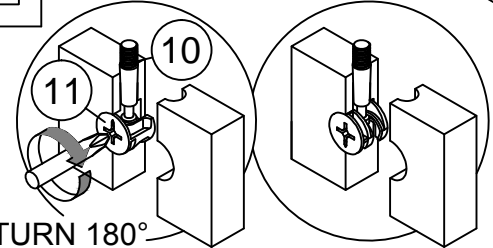
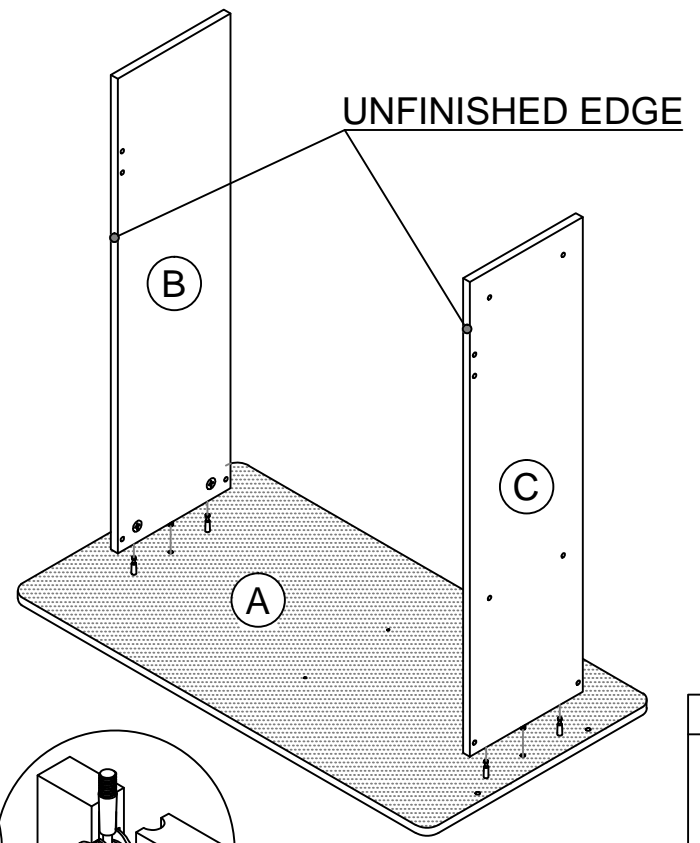

TOOL REQUIRED

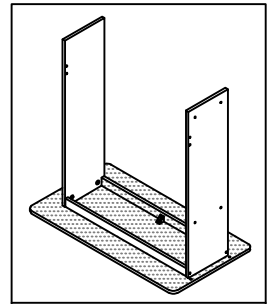

ASSEMBLED UNIT

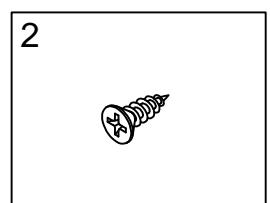

SHORT SCREW 2 PCS

### STEP 7

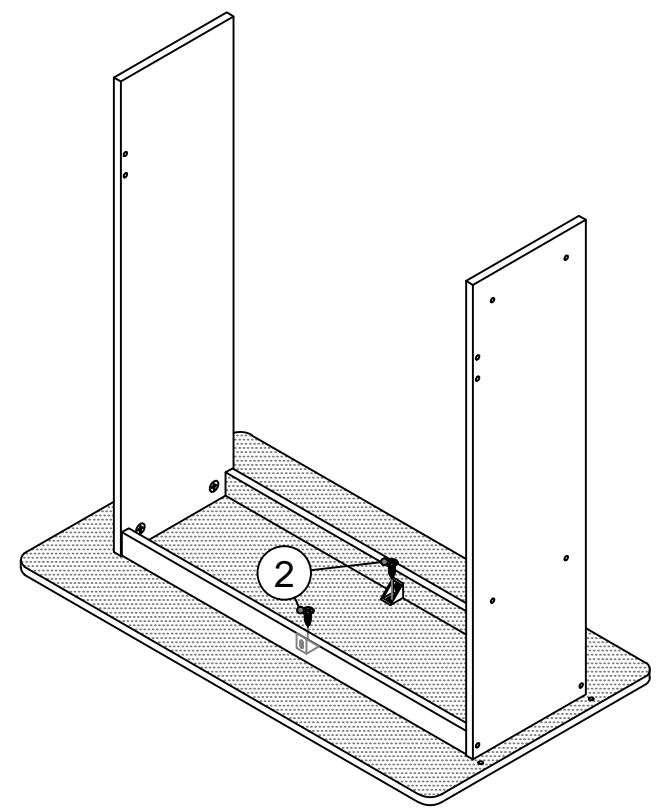

TOOL REQUIRED

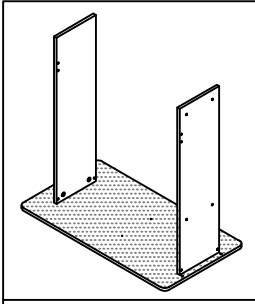

ASSEMBLED UNIT

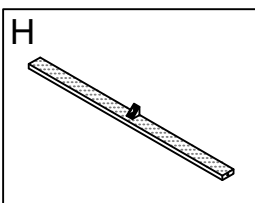

SKIRT PANEL 2 PCS

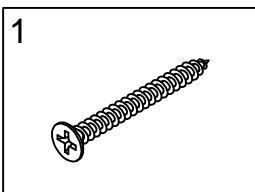

LONG SCREW 4 PCS

### STEP 6

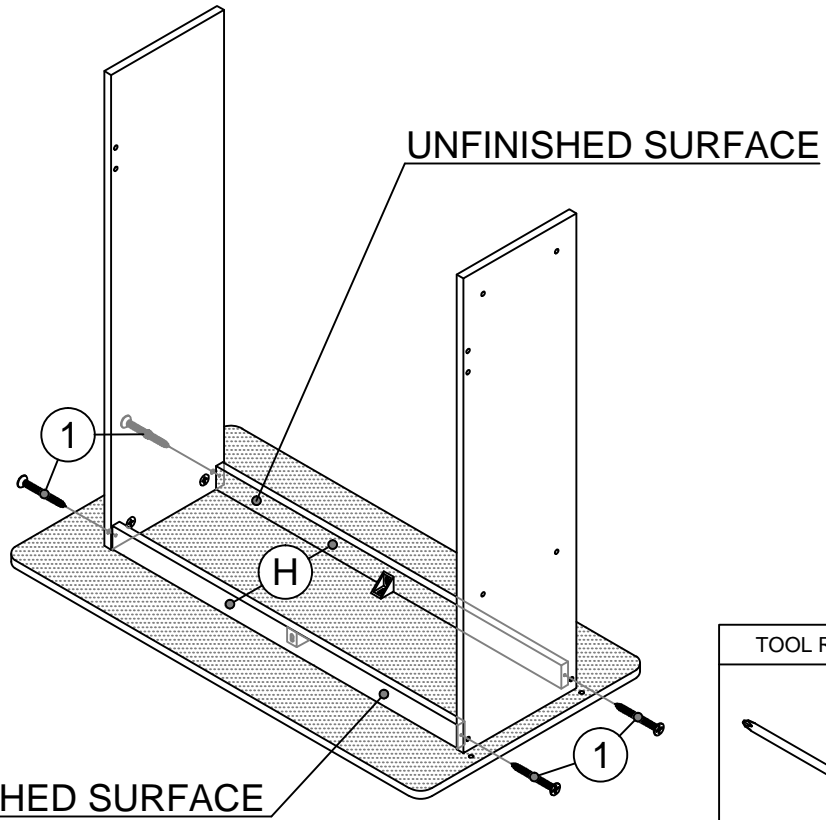

TOOL REQUIRED

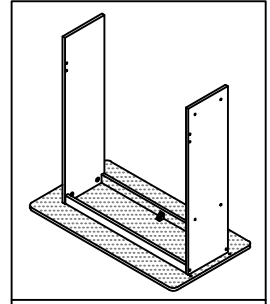

ASSEMBLED UNIT

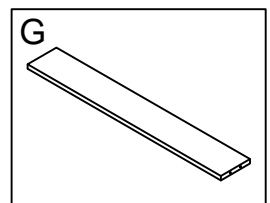

BOTTOM CROSS BAR 1 PC

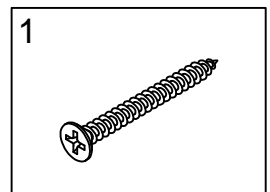

LONG SCREW 4 PCS

### STEP 8

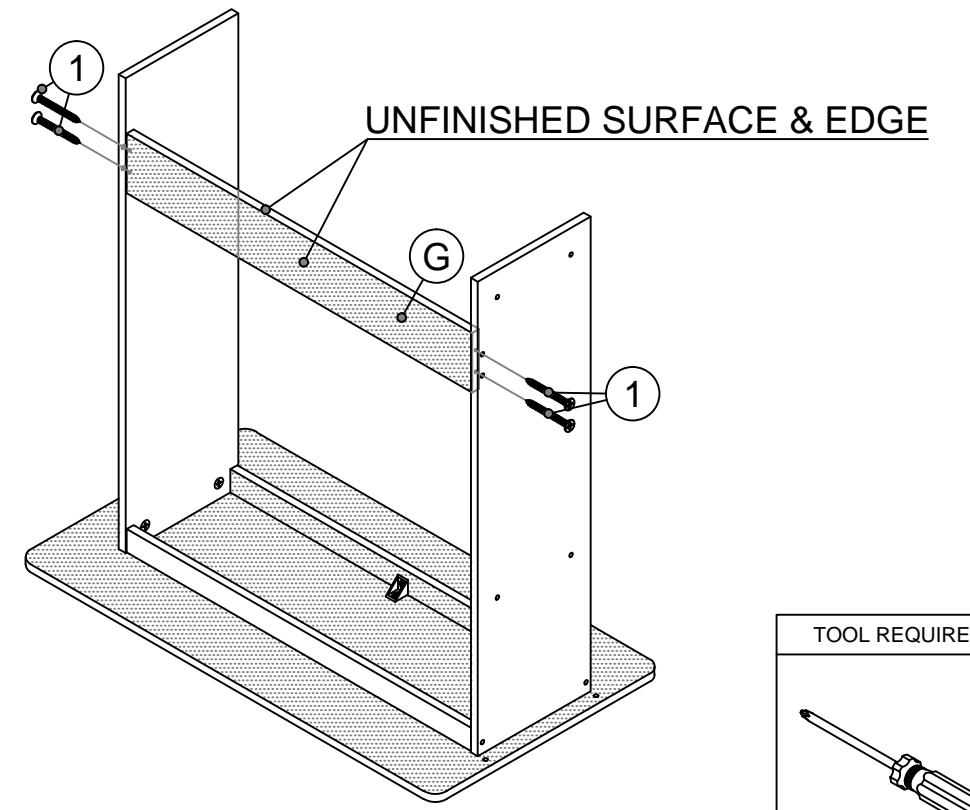

TOOL REQUIRED