

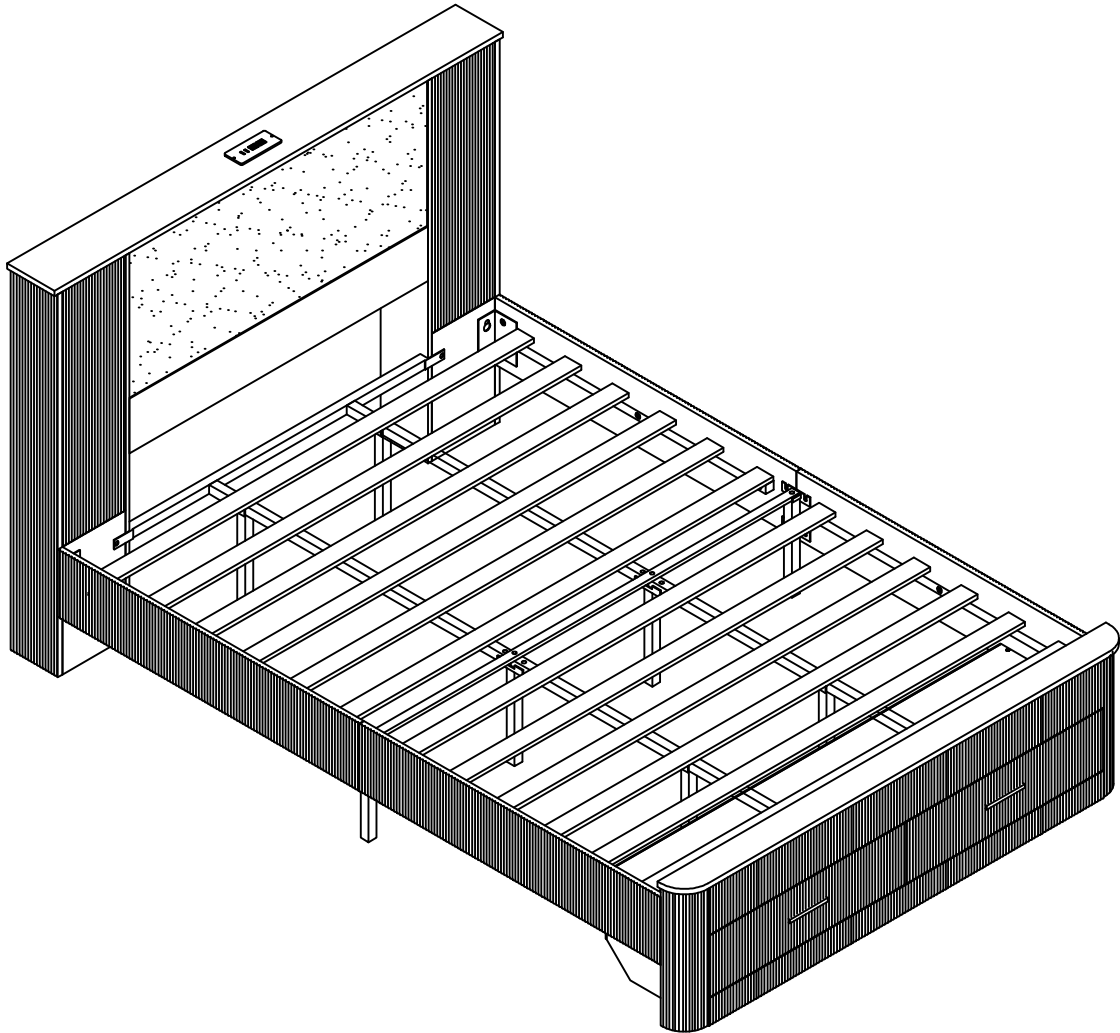

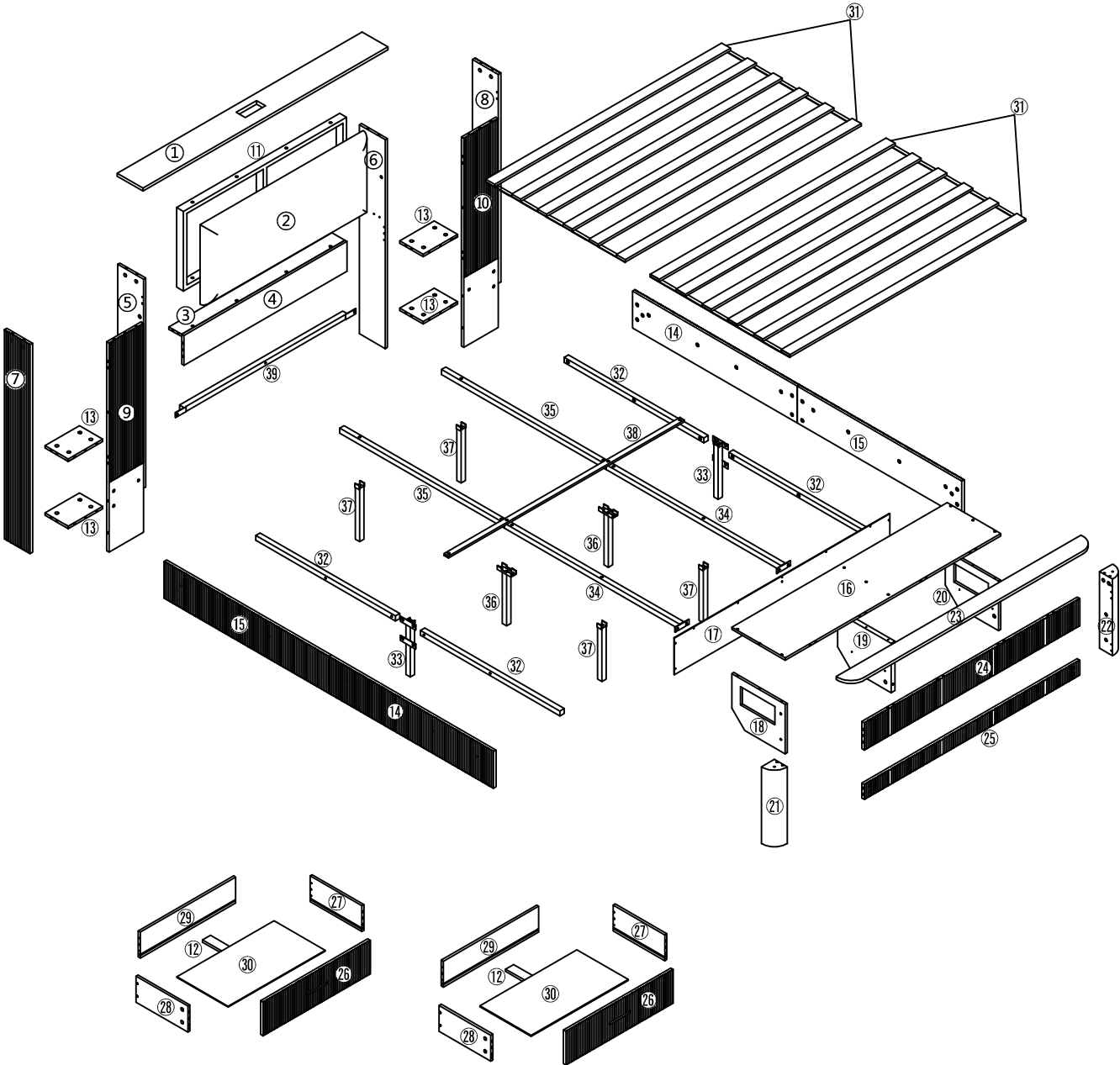









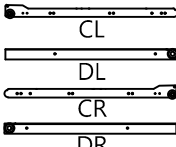









ASSEMBLY INSTRUCTIONS



Parts List



Hardware List

 A(x101+1)	 M4*12 B(x26+4)	 CL DL CR DR L=300 C(x2)	 M8*20 D(x12)	 M6*30 E(x42+1)
 D=15 F(x101+1)	 m5*40 G(x9)	 M3.5*25 H(x8)	 M4*22 I(x4)	 J(x2)
 K(x4)	 M8*12 L(x20)	 M8*35 M(x22)	 M3.5*20 N(x11)	 M8*40 O(x6)
 P(x1)	 Q(x1)	 R (X1)	 M8*25 S(x8)	 M8*50 T(x2)
 M4*15 U(x10)	 V(x4)			

Step 1

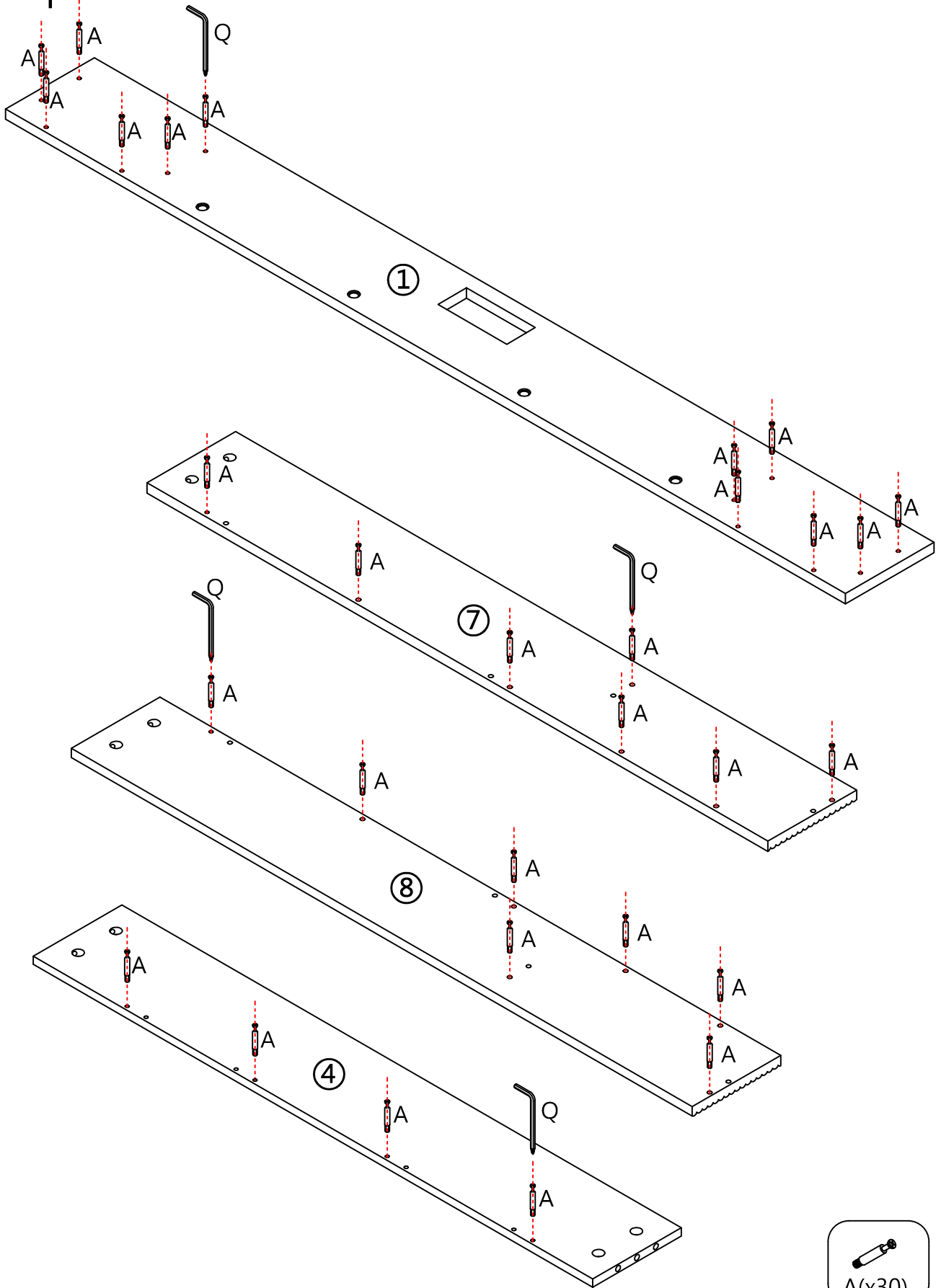

Step 2

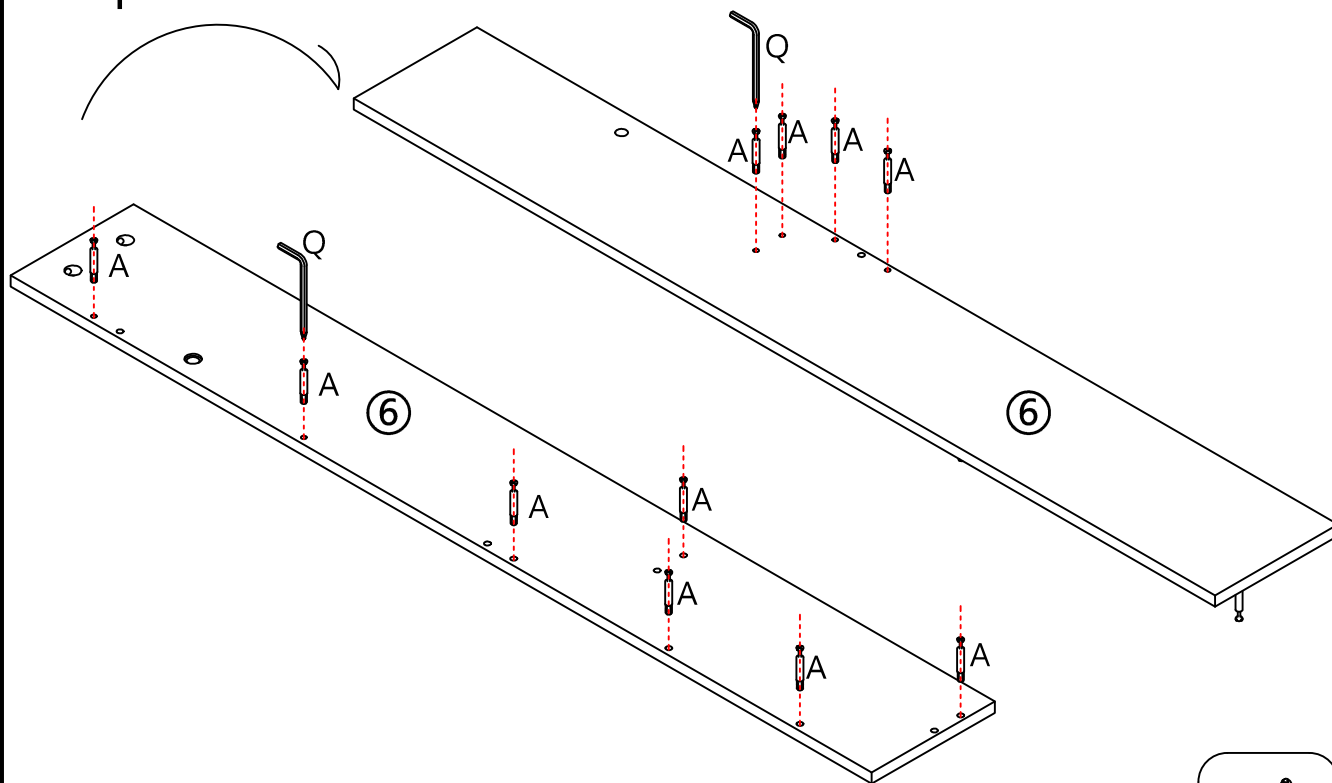

Step 3

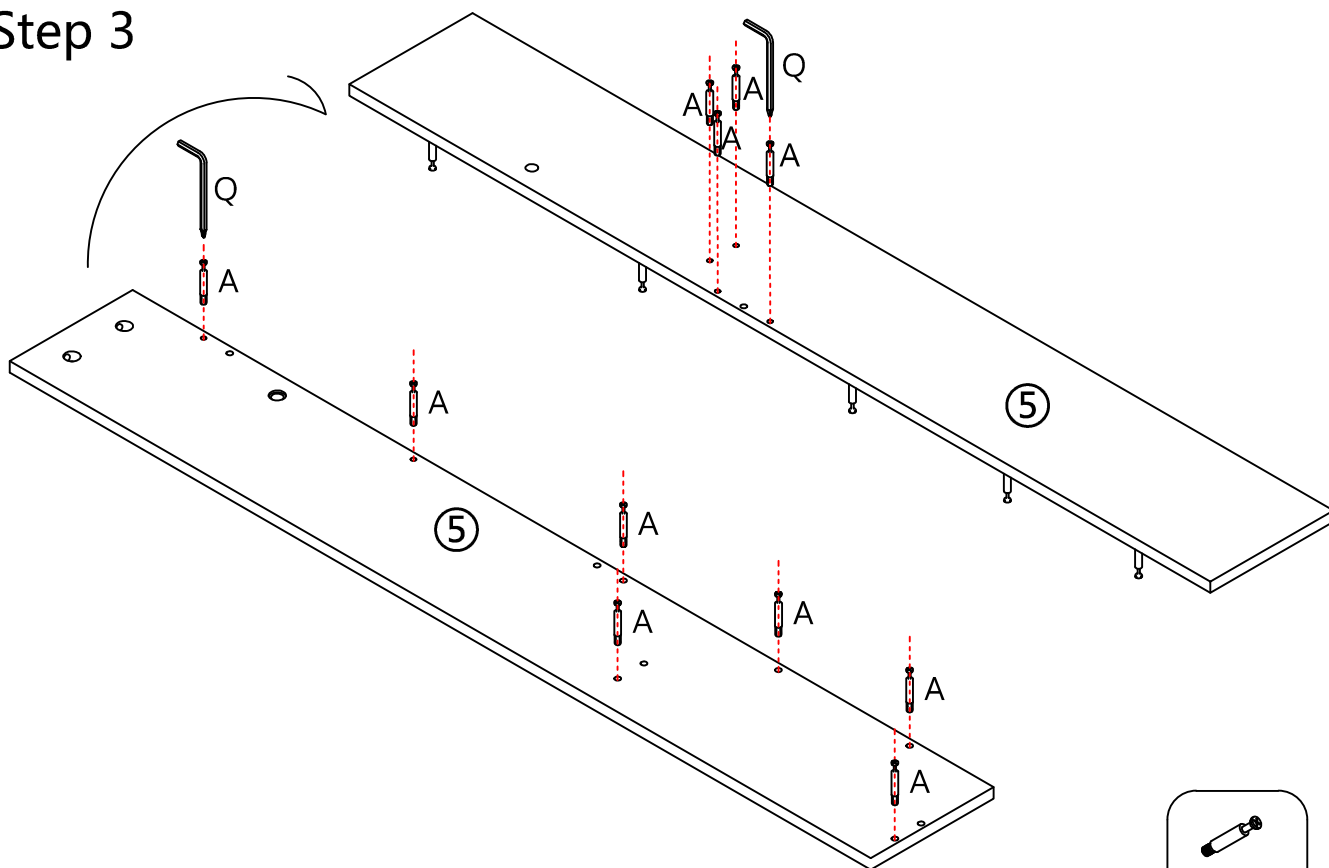

Step 4

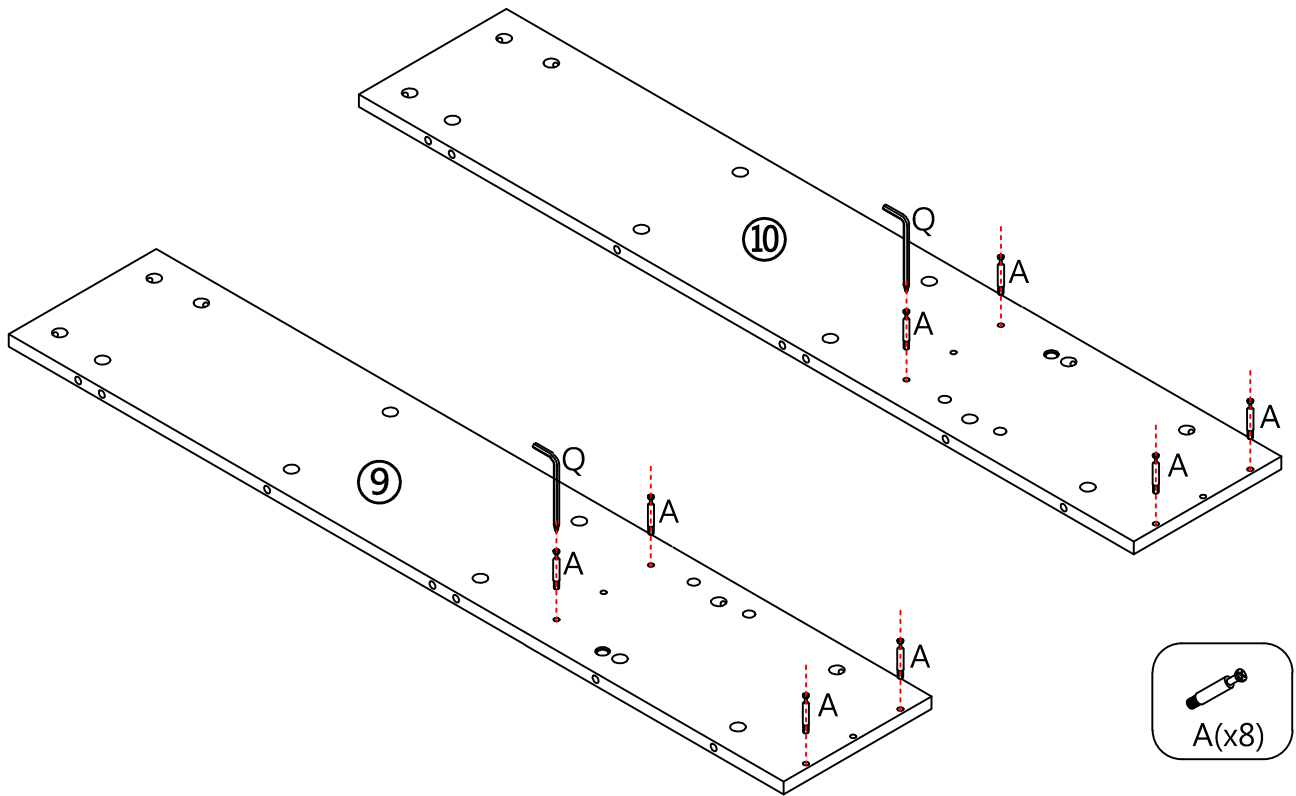

Step 5

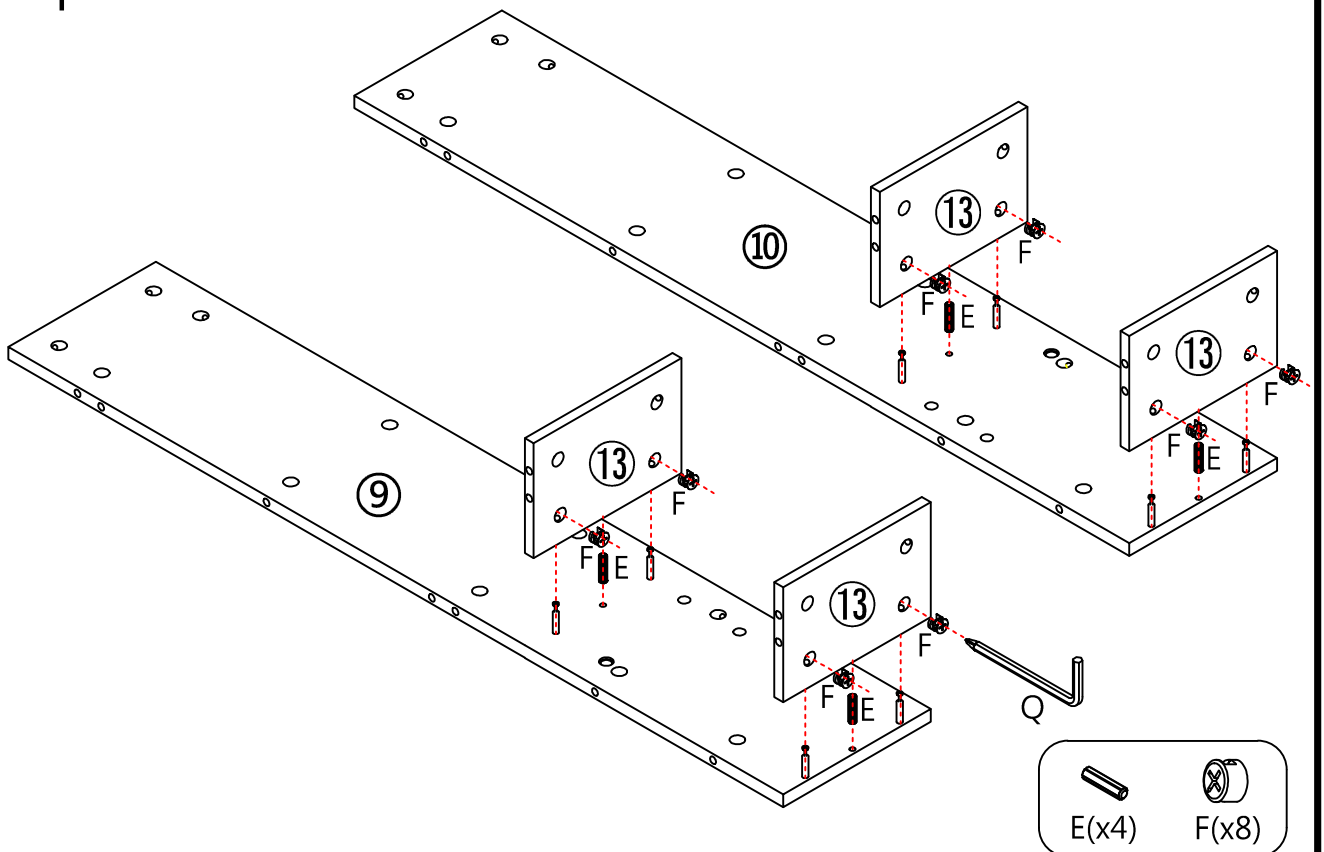

Step 6

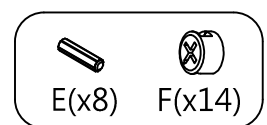
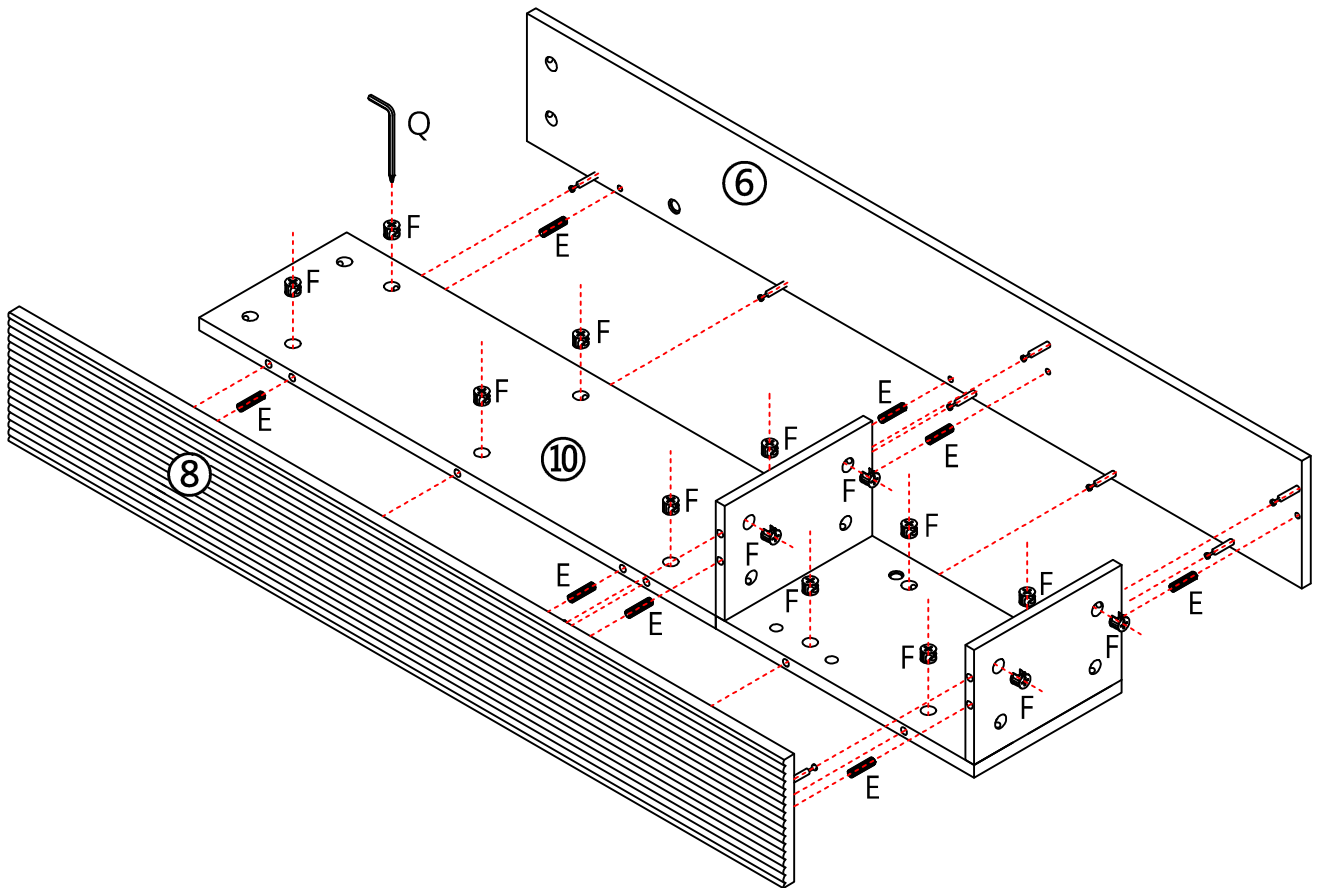

Step 7

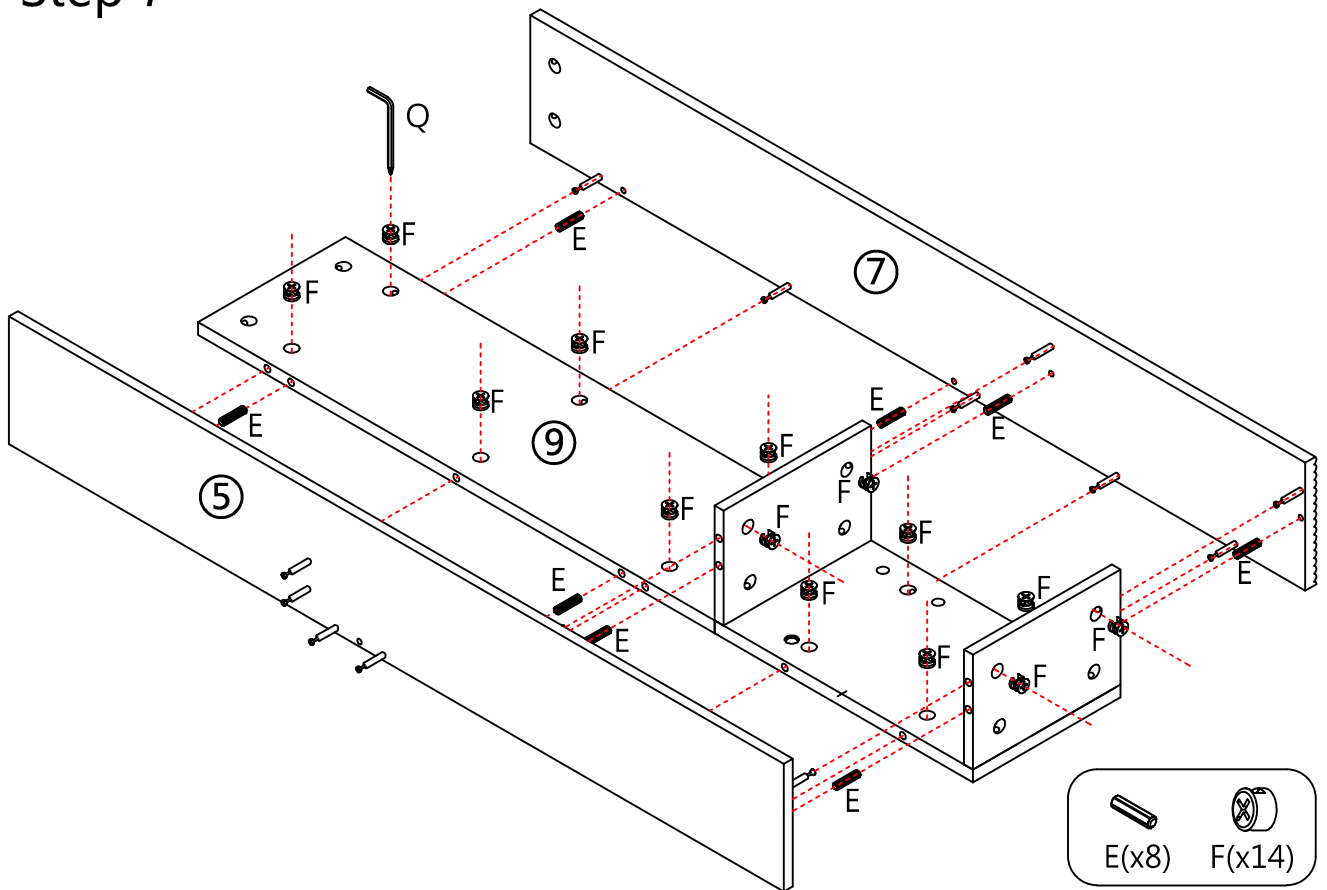

Step 8

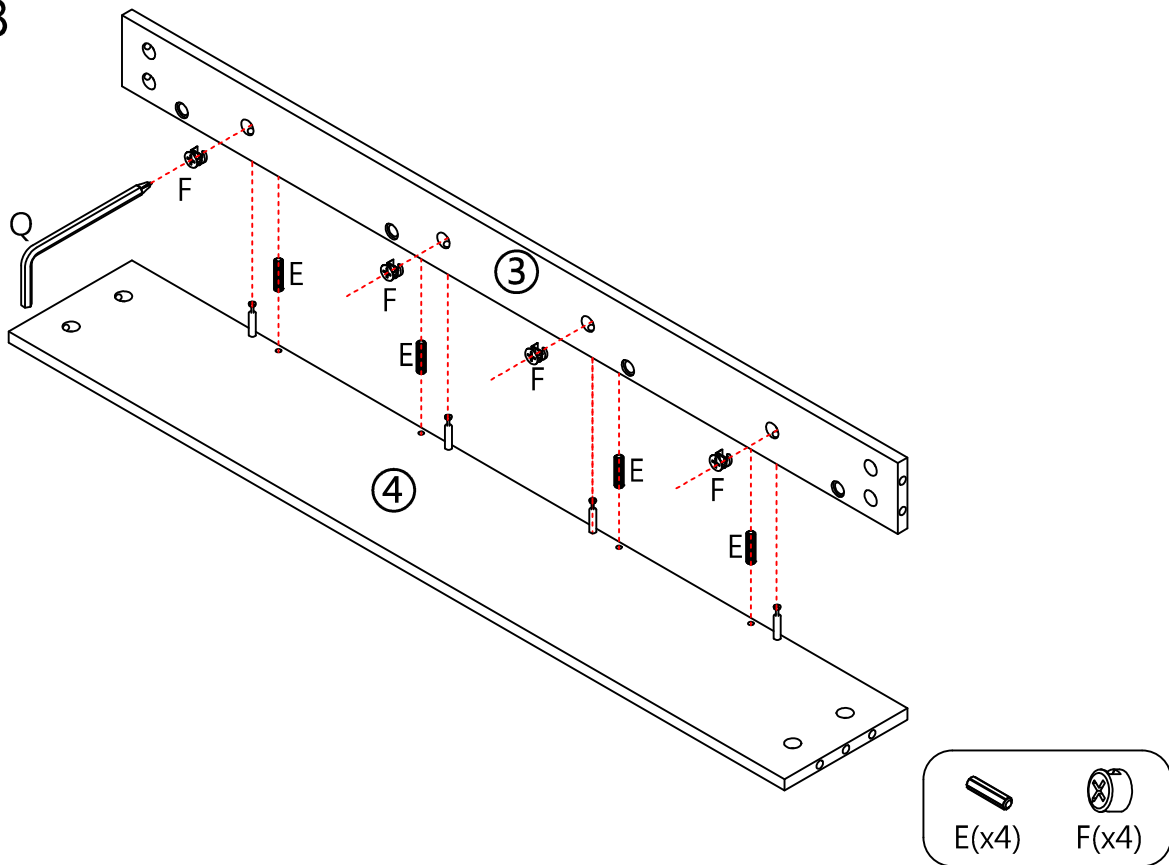

Step 9

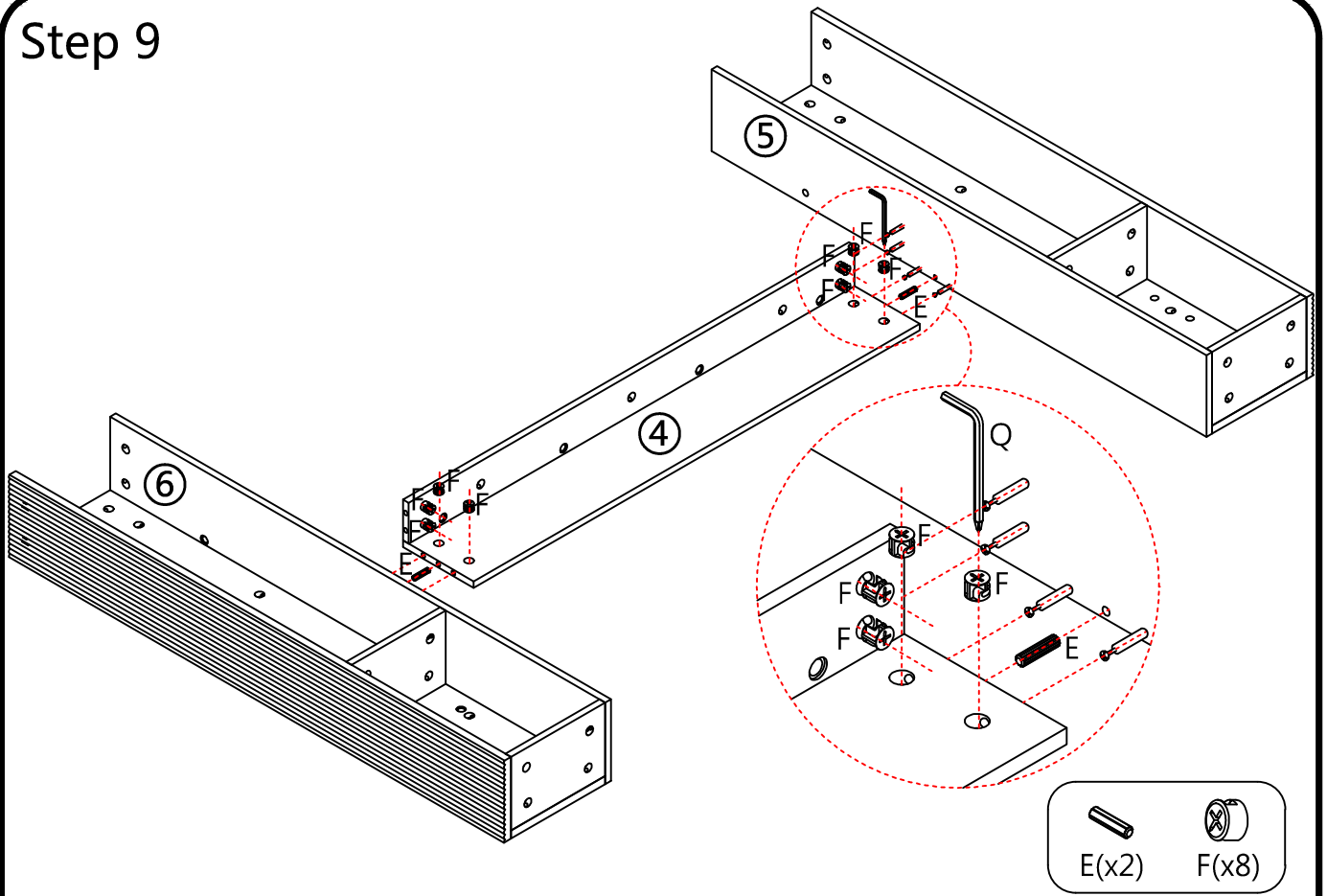

Step 10

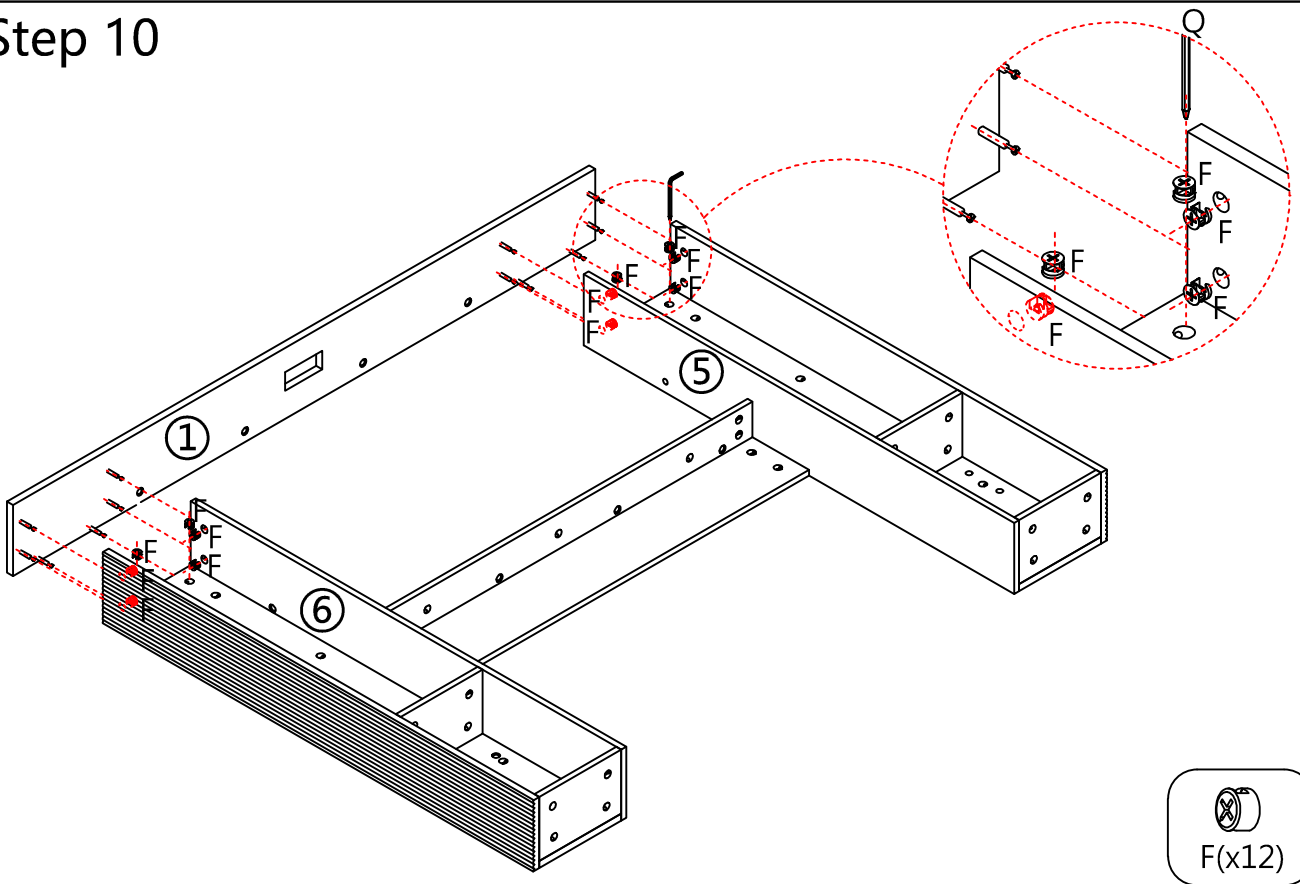

Step 11

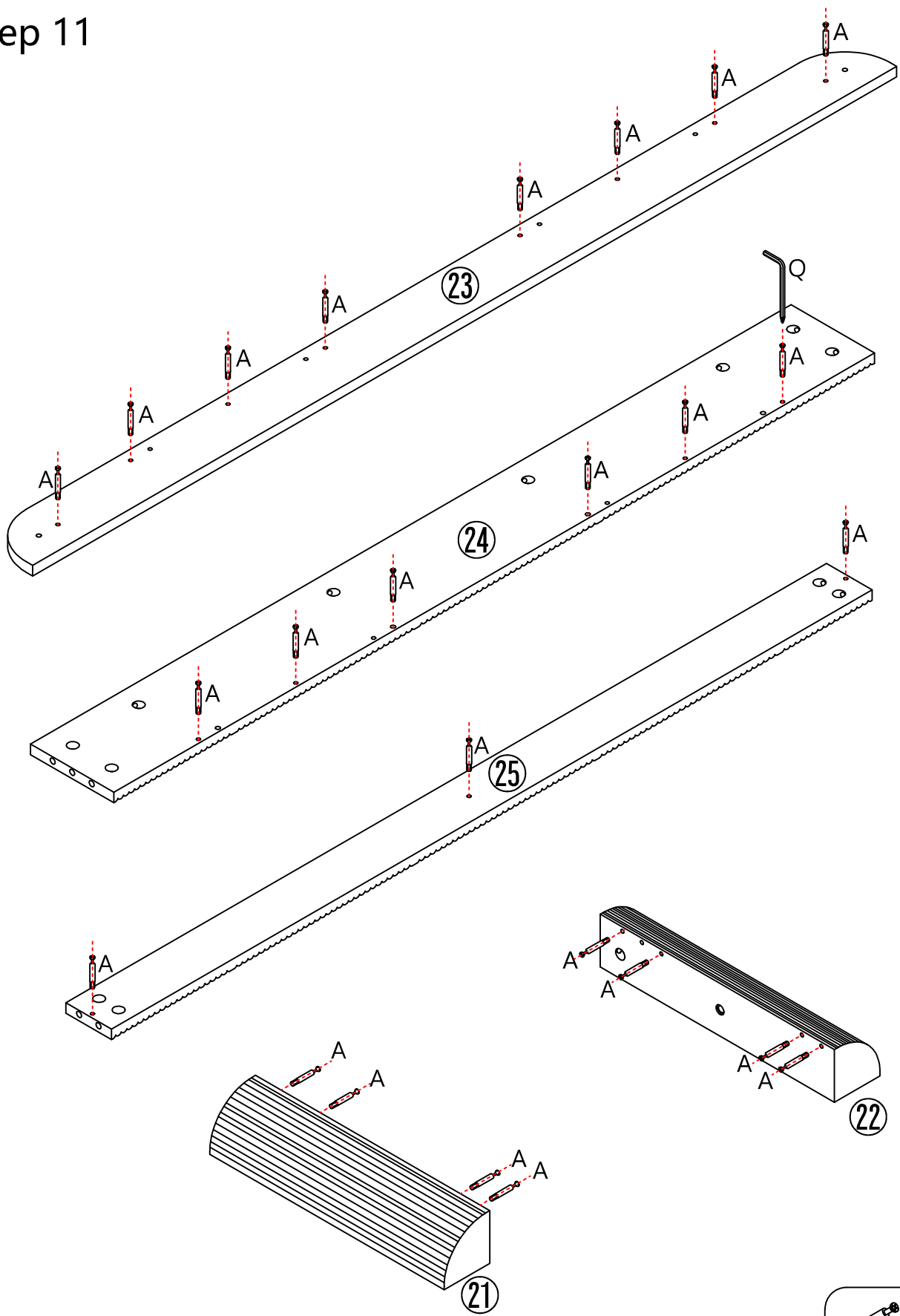

Step 12

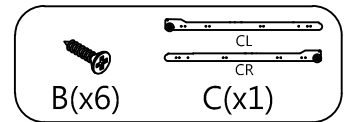
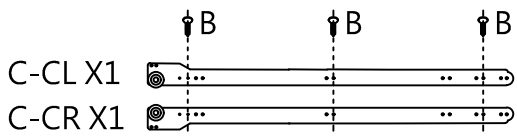
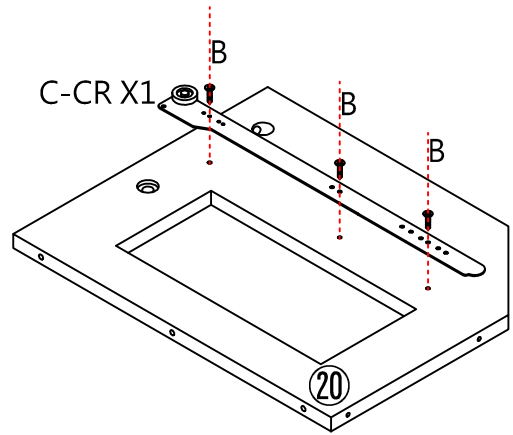
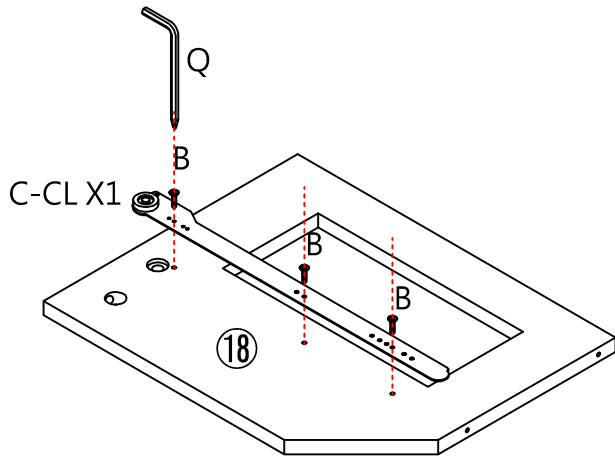

Step 13

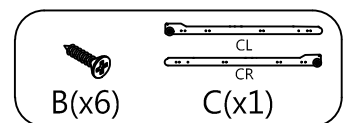
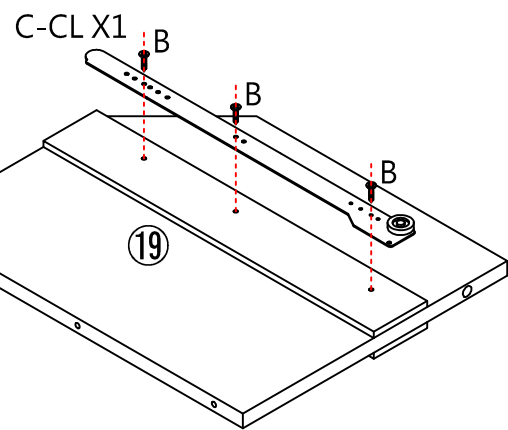
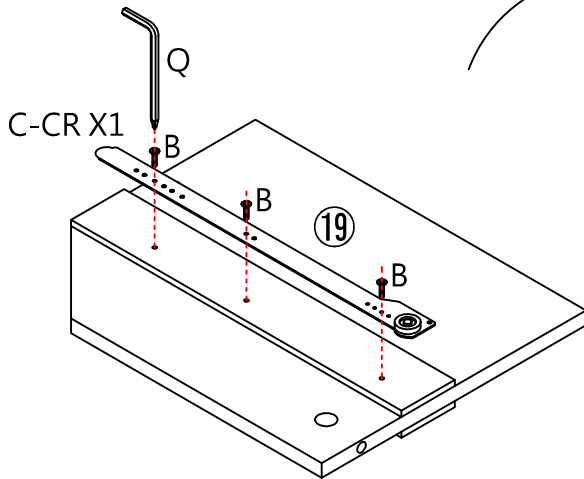

Step 14

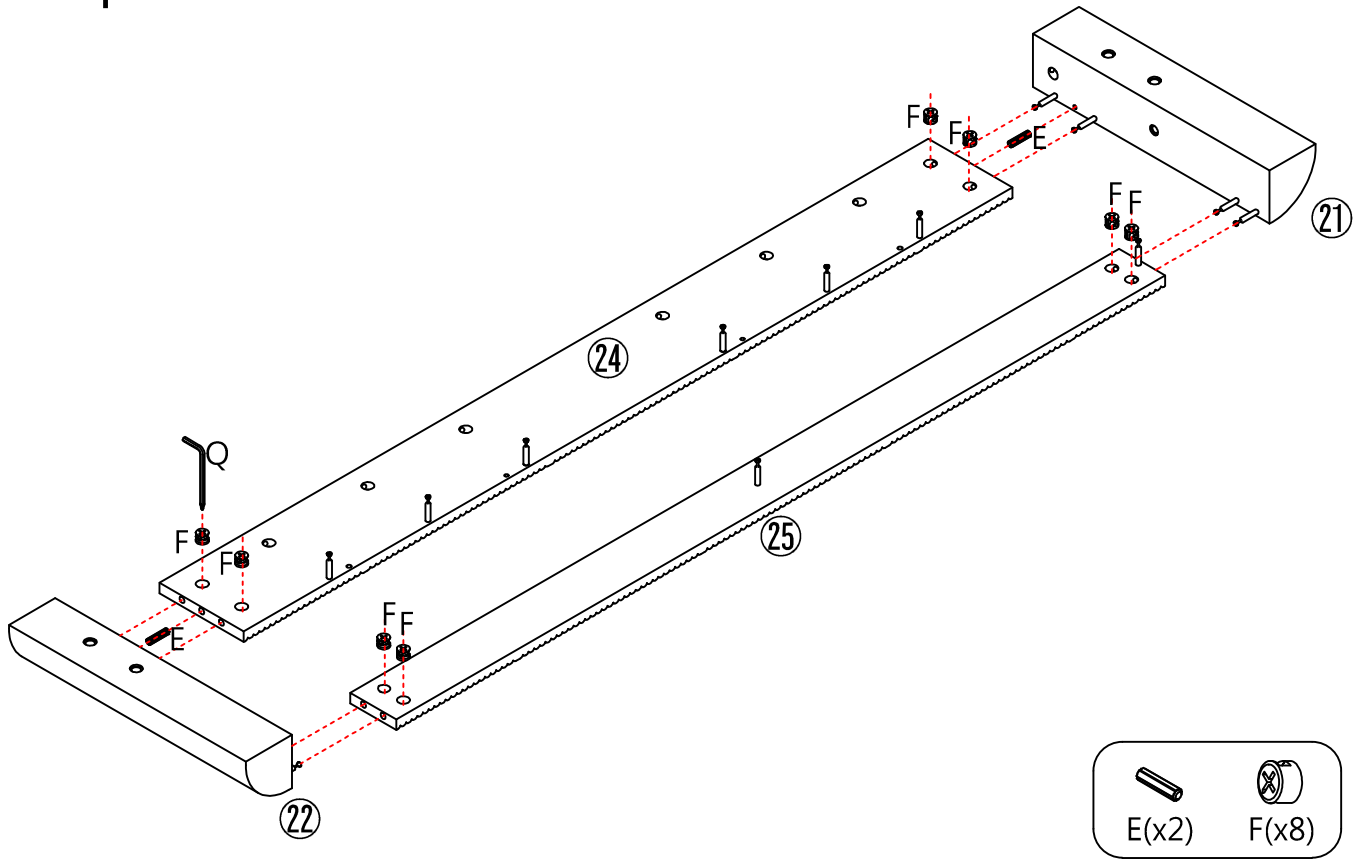

Step 15

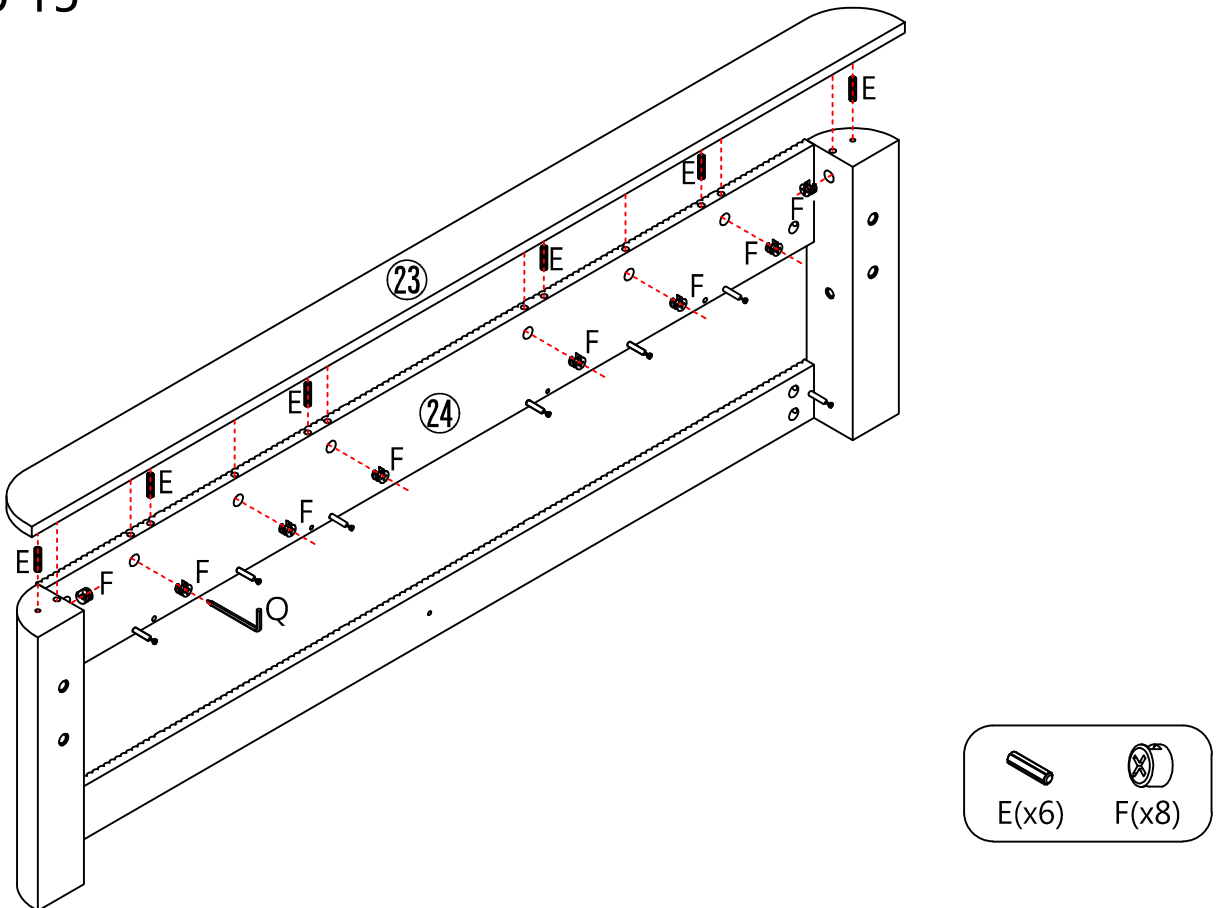

Step 16

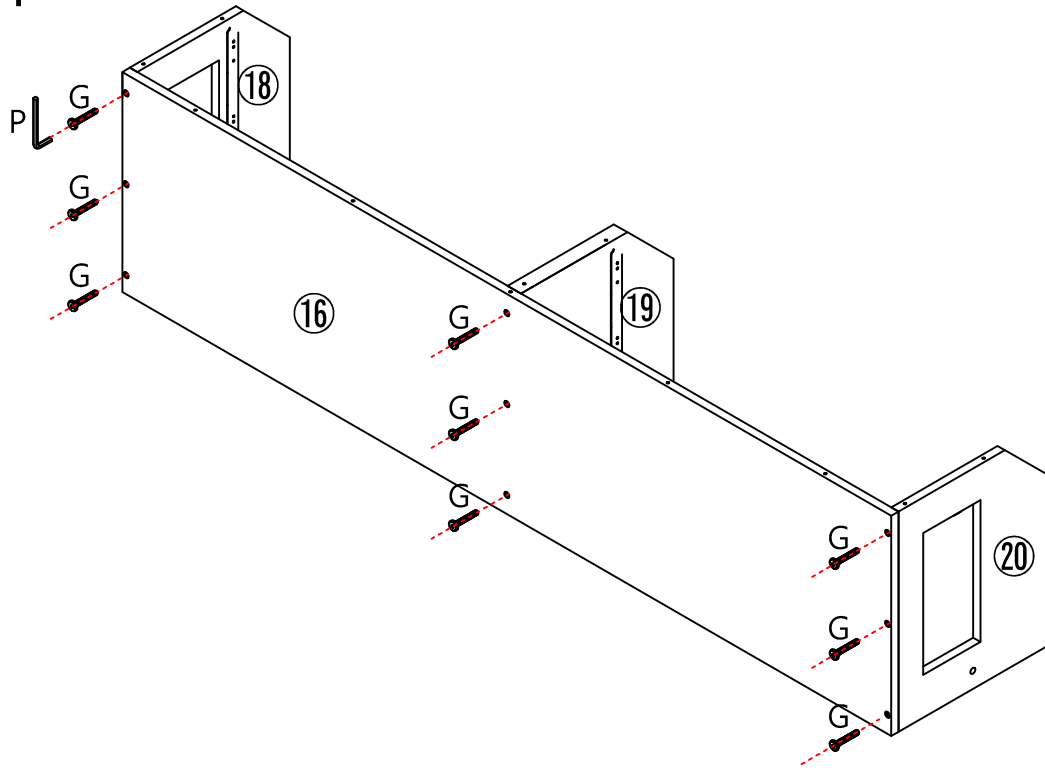

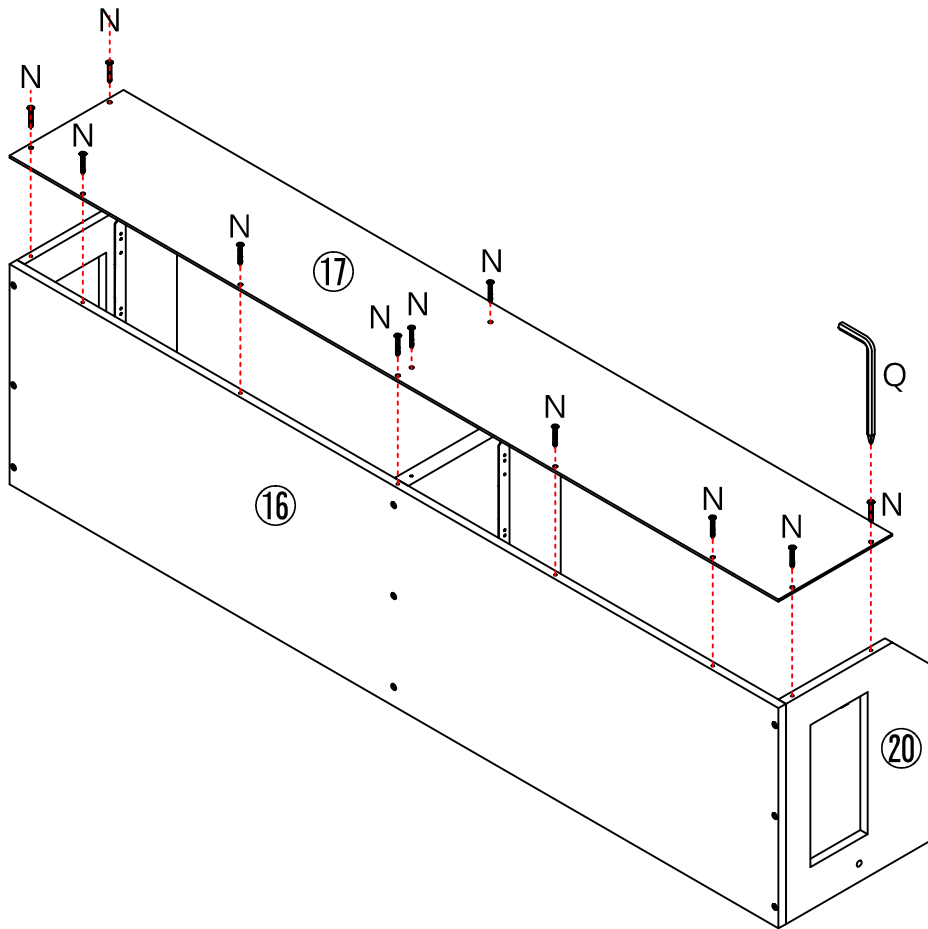

Step 17

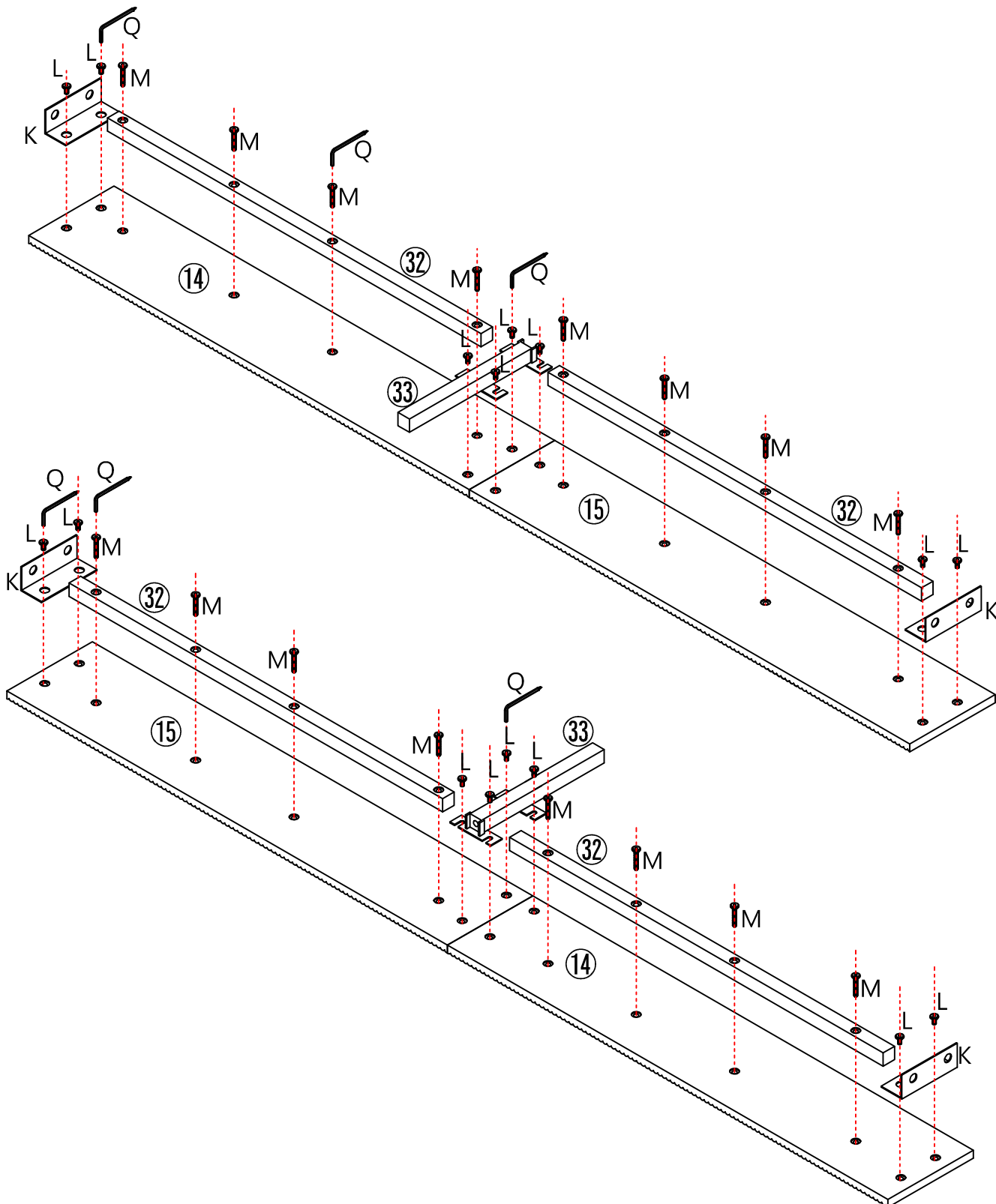

Step 18



		
K(x4)	L(x16)	M(x16)

Step 19

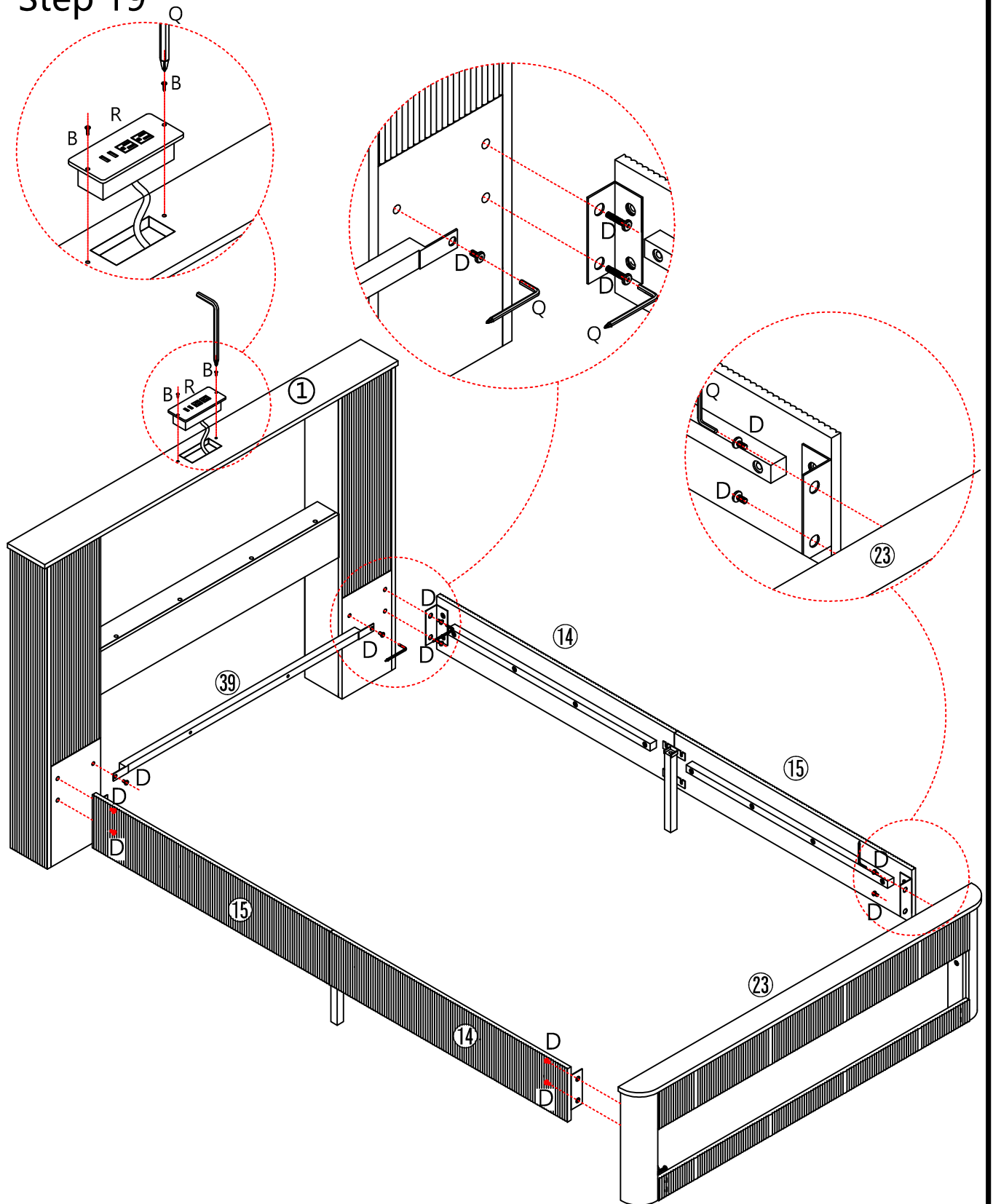

- R (X1)
- B (x2)
- D (x10)

Step 20

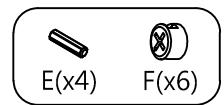
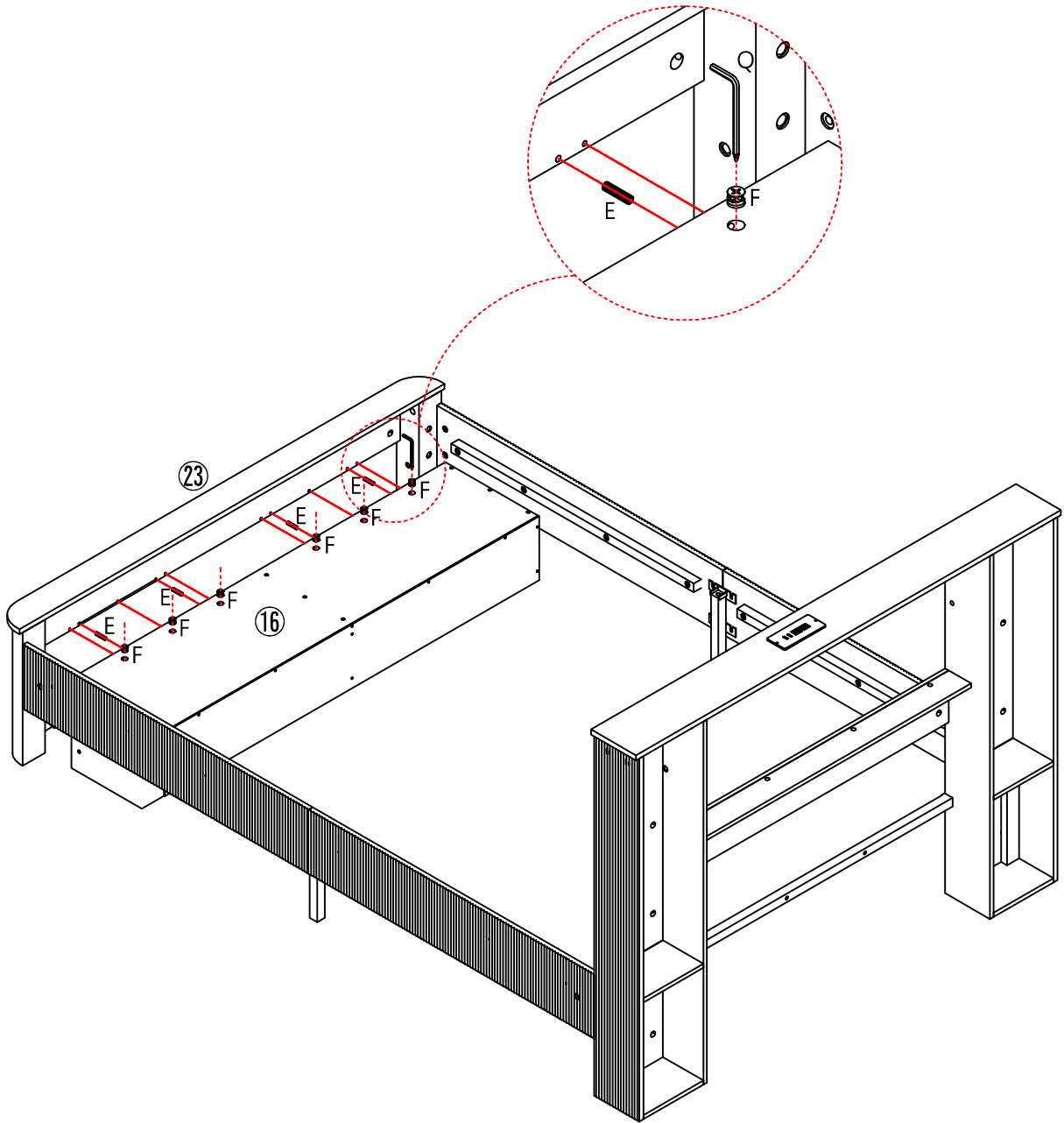

Step 21

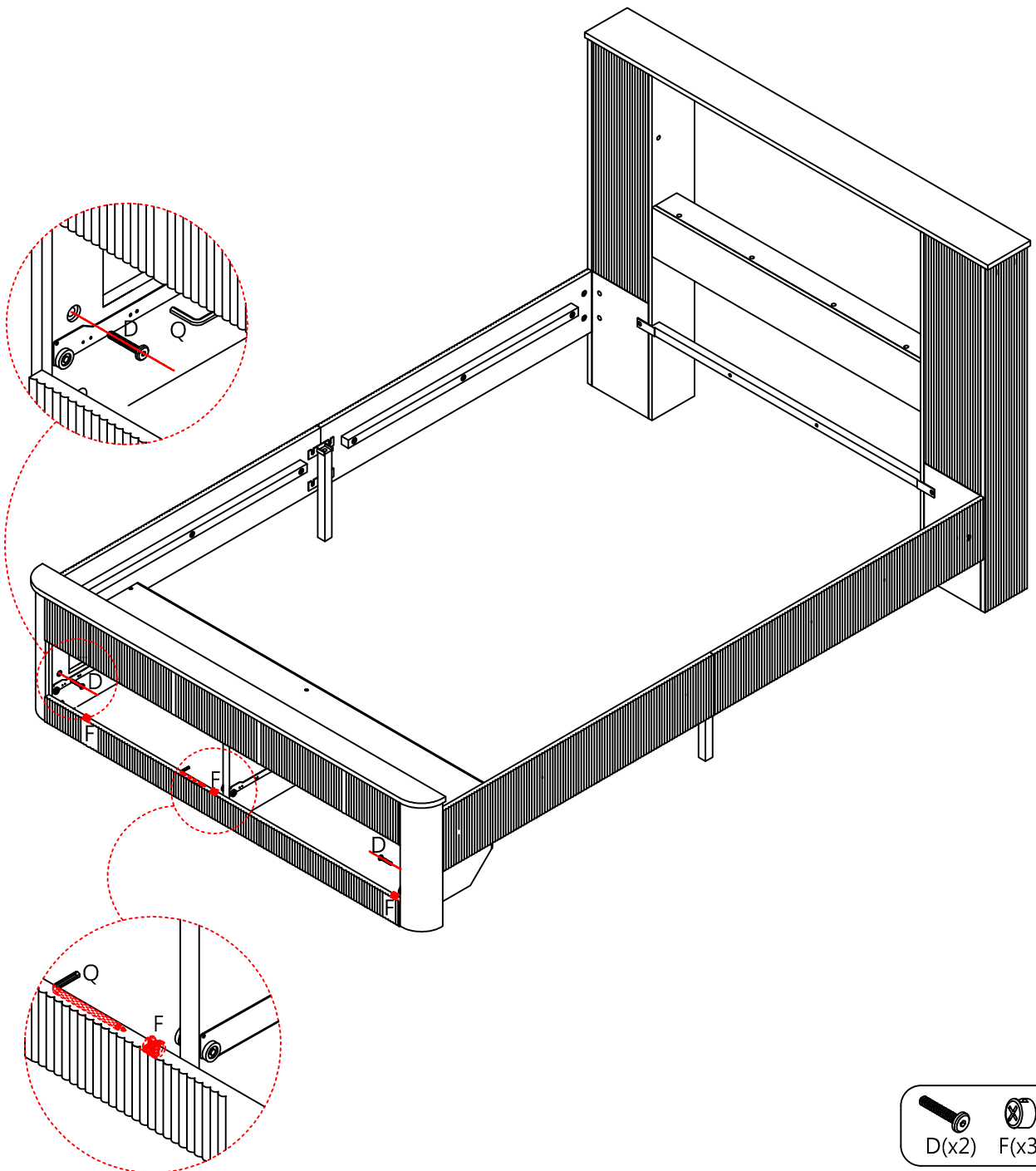

Step 22

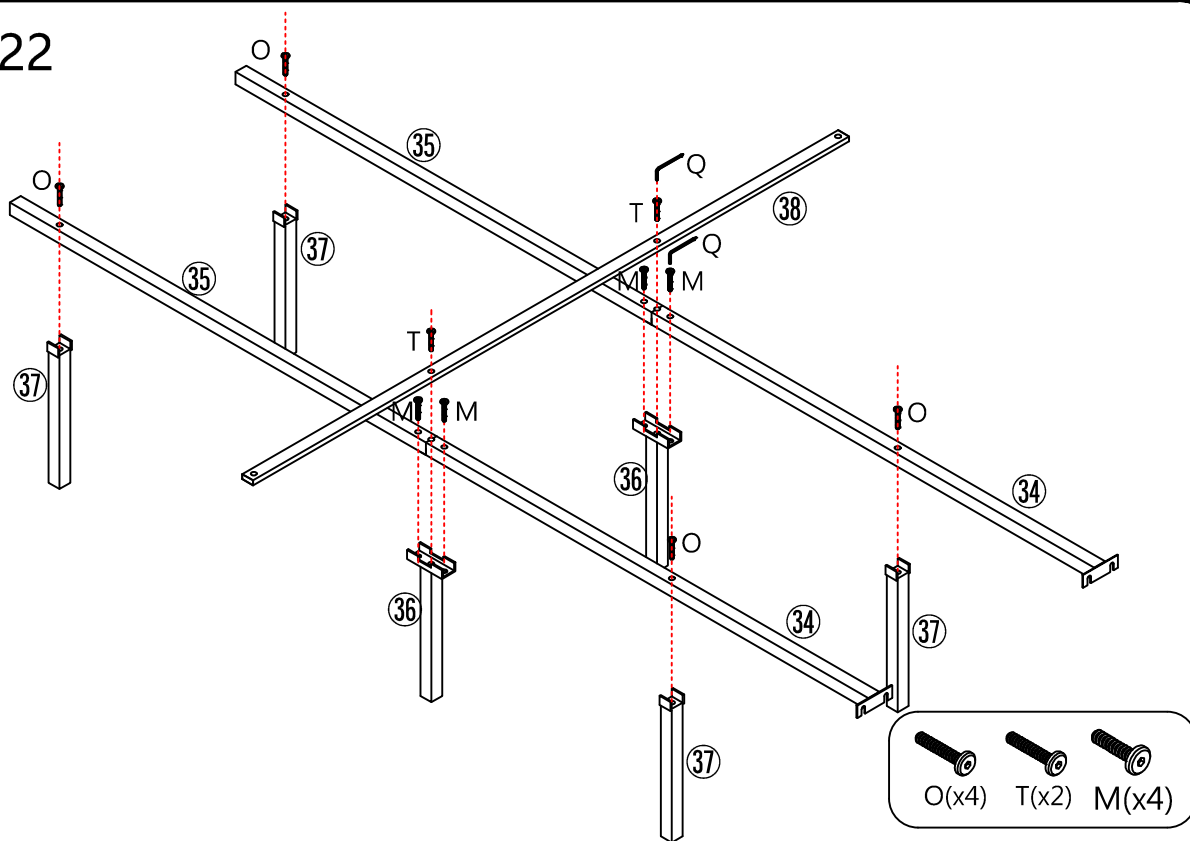

Step 23

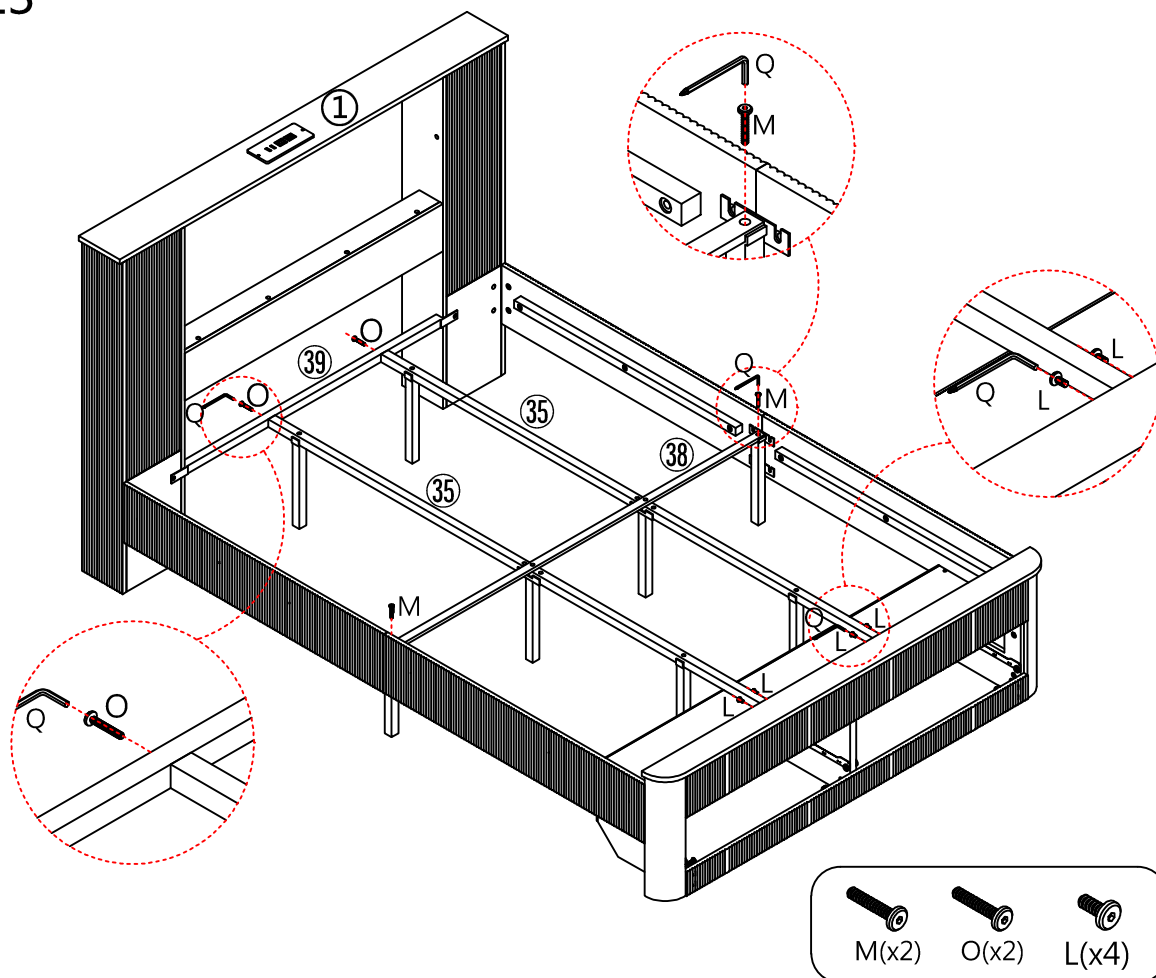

Step 24

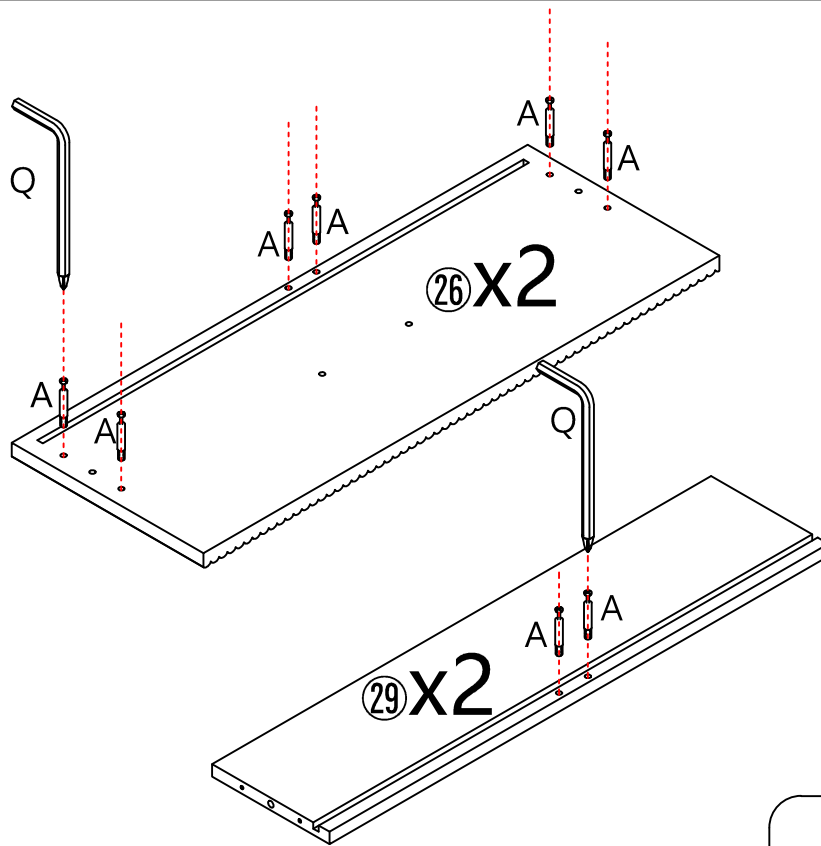

Step 25

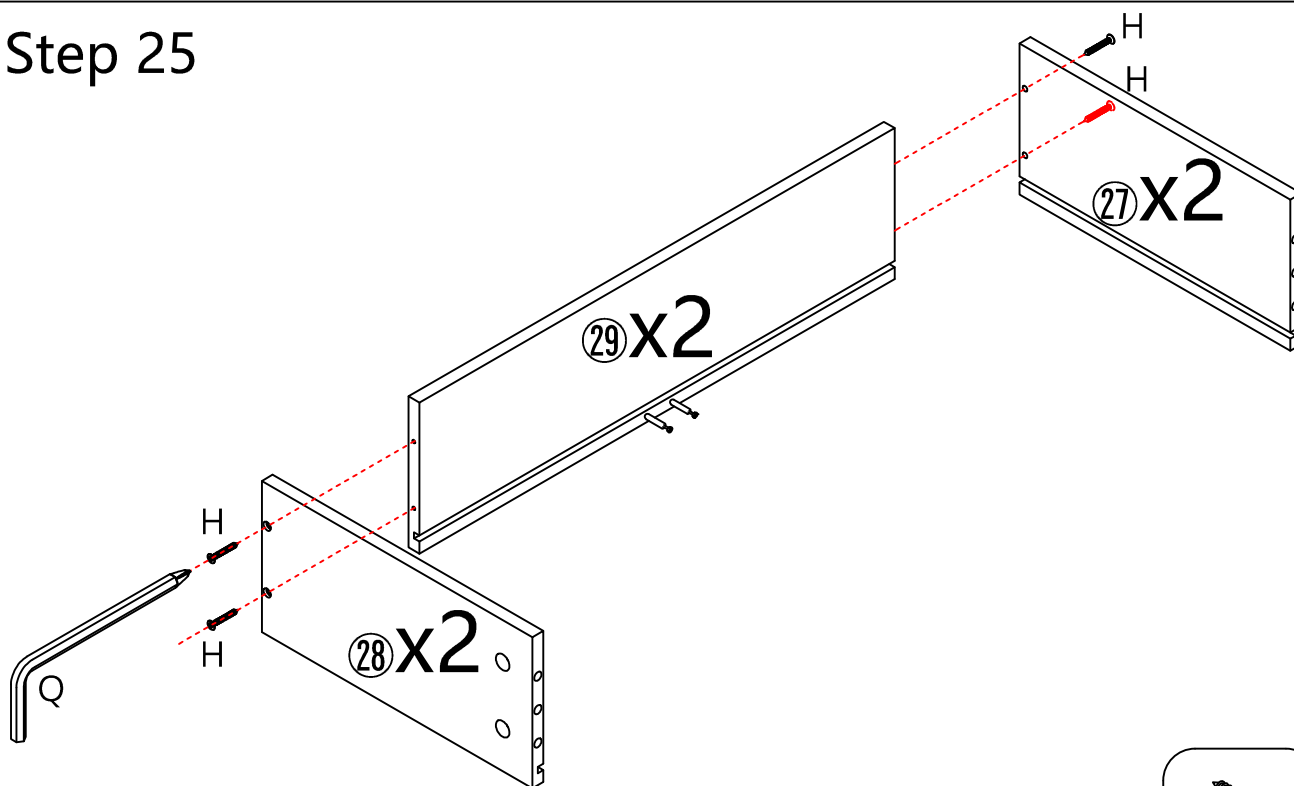

Step 26

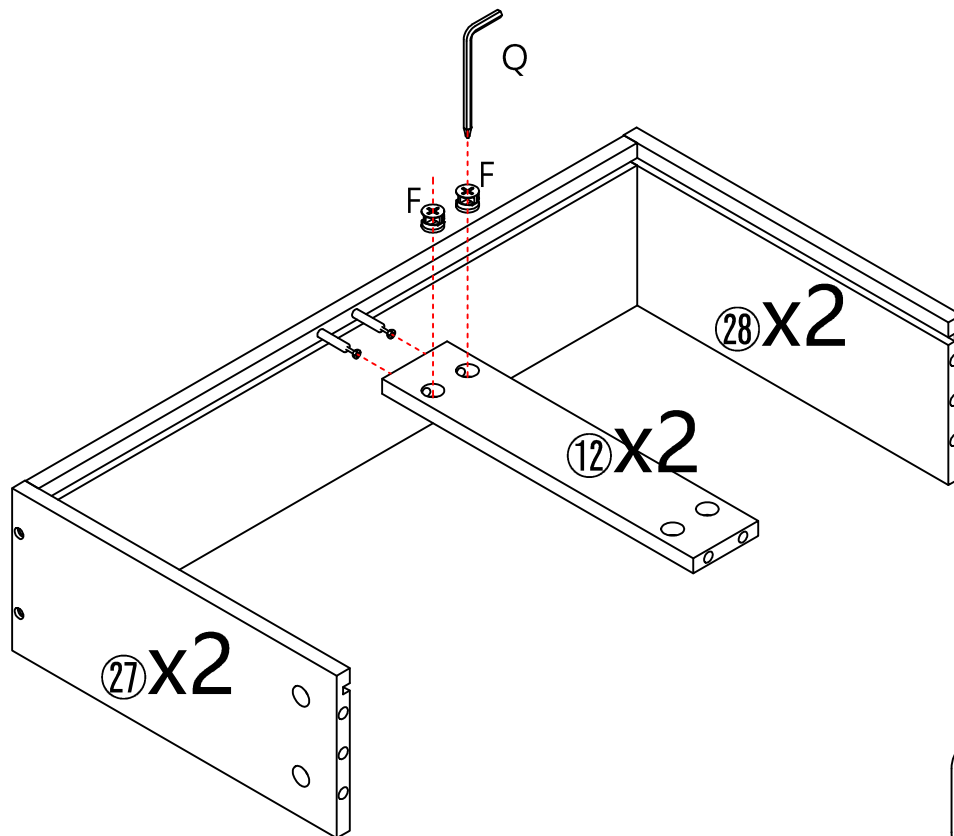

Step 27

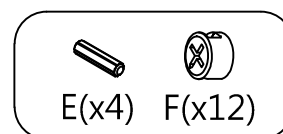
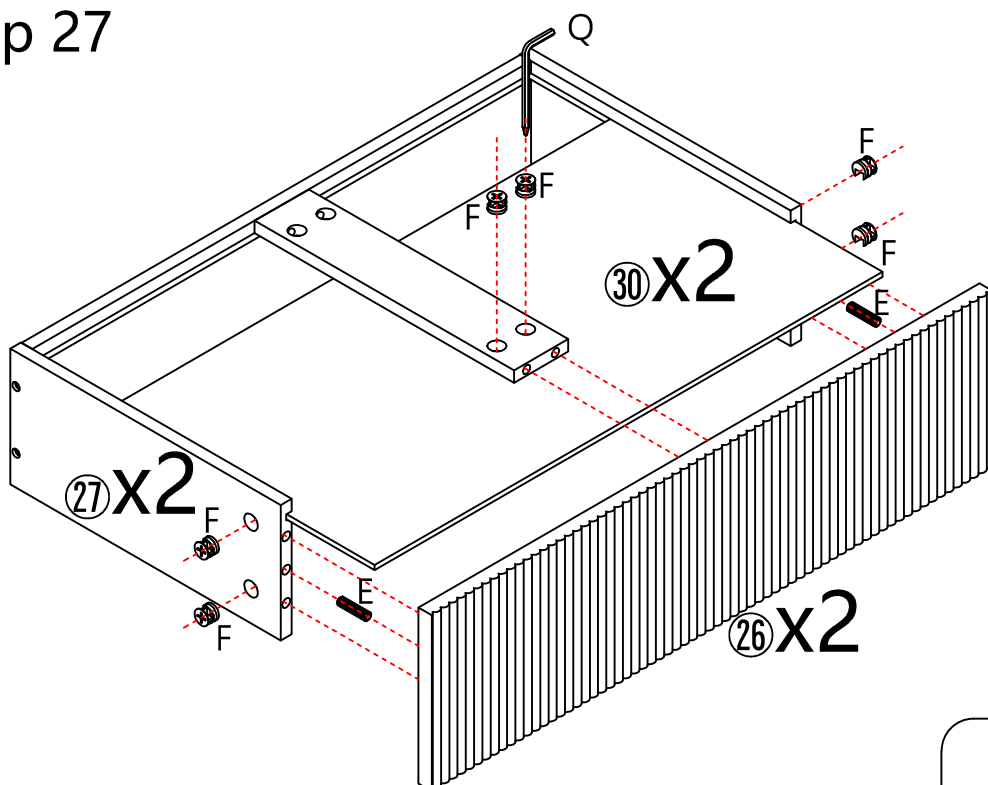

Step 28

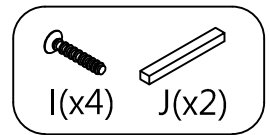
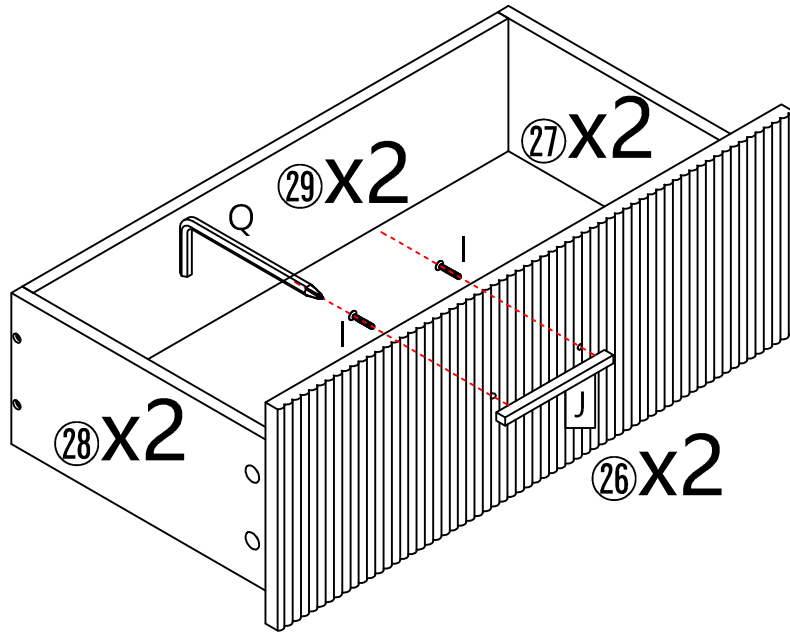

Step 29

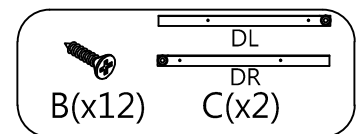
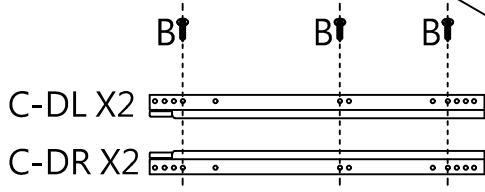
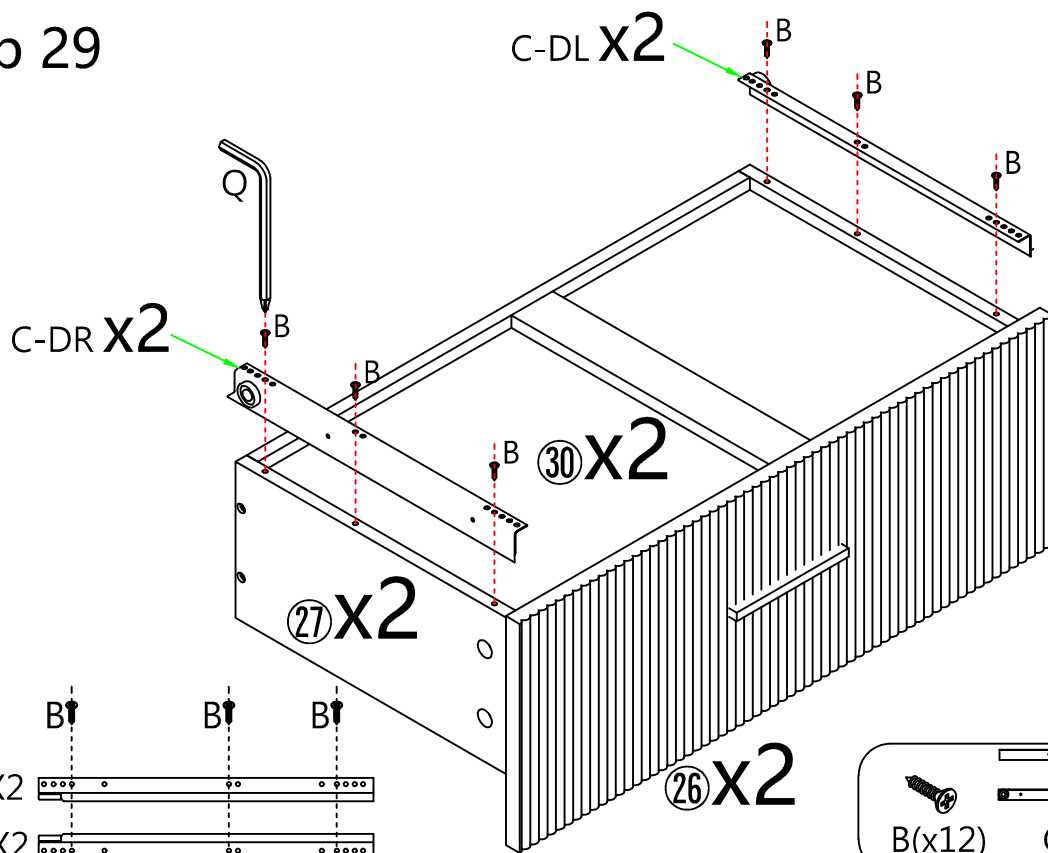

Step 30

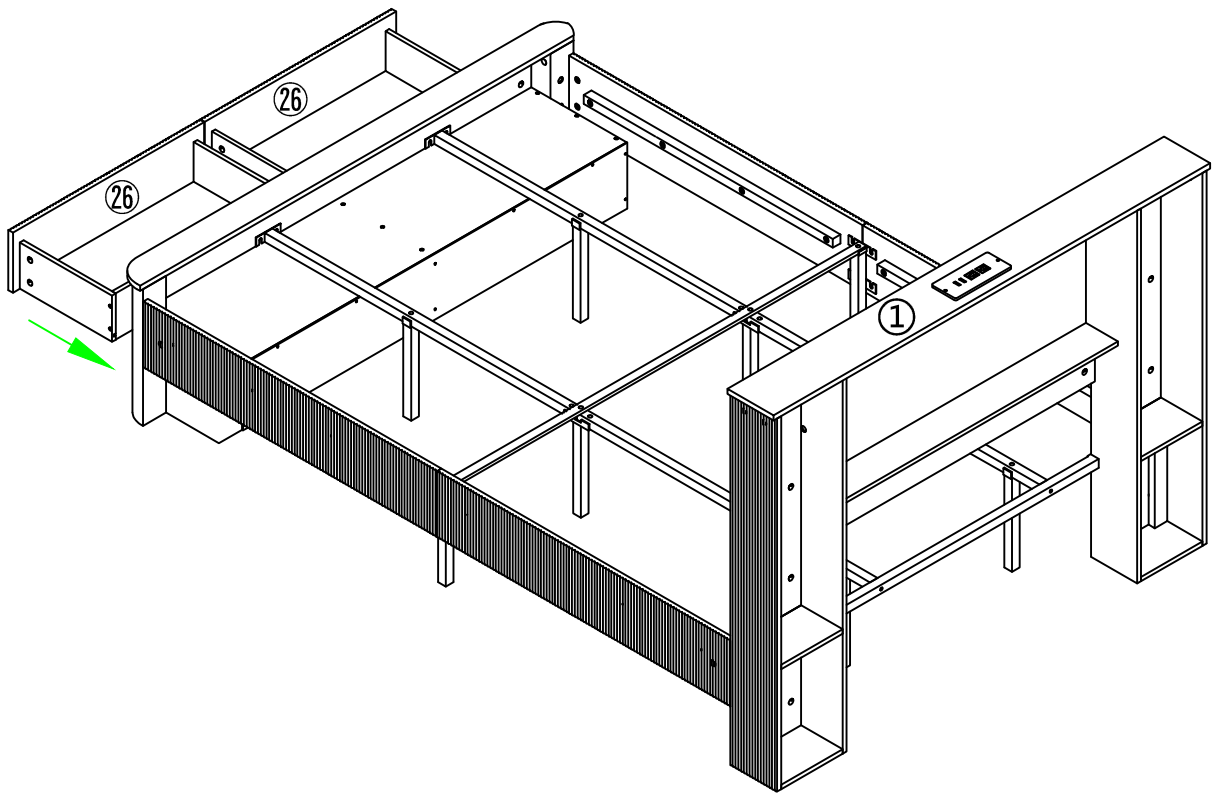

Step 31

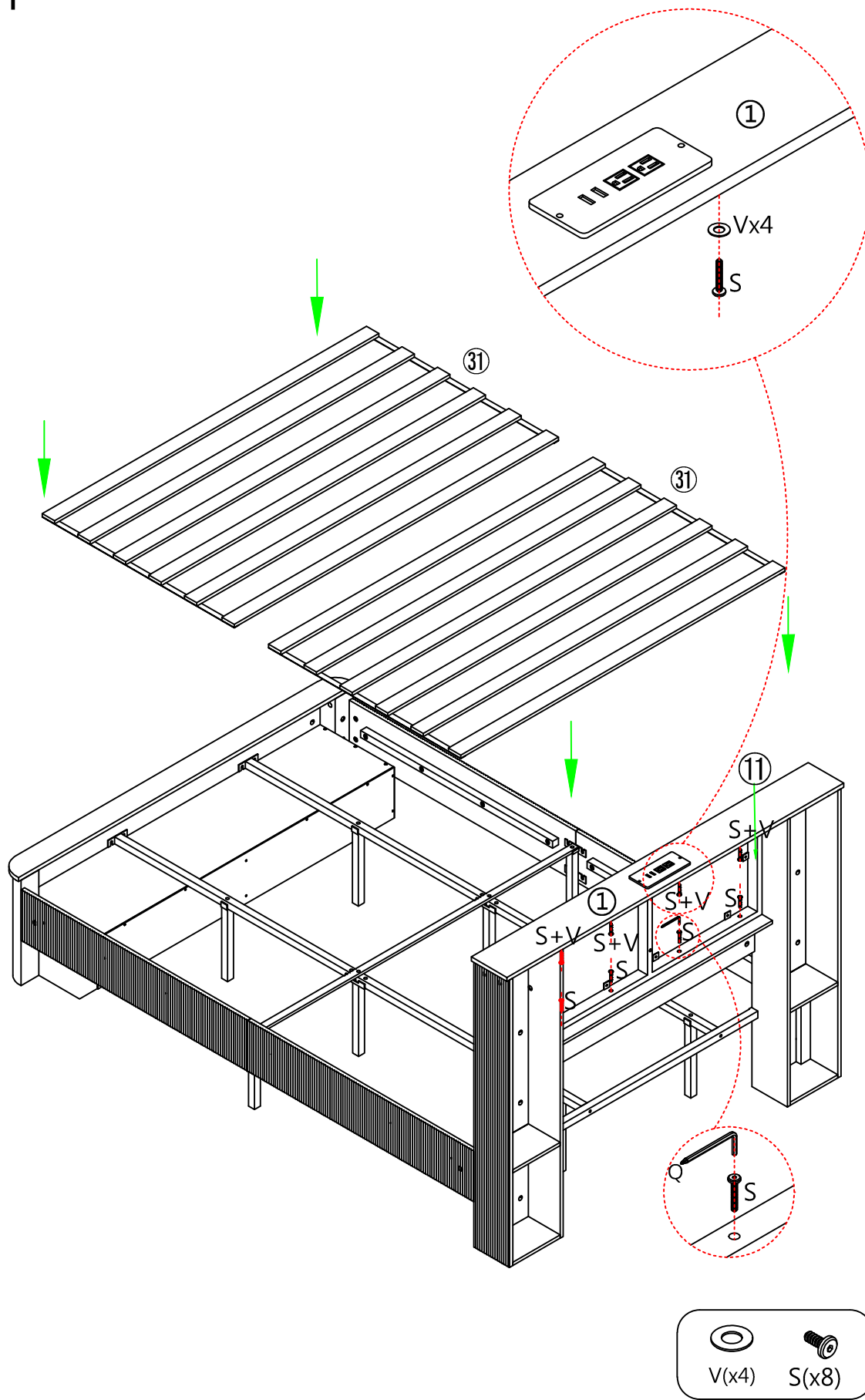

Step 32

