

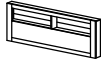









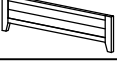

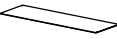



# ASSEMBLY INSTRUCTIONS

## PART LIST

ITEM	DRAWING	DESCRIPTION	QTY
A		HEADBOARD PANEL	1
B1		LEFT HEADBOARD LEG	1
B2		RIGHT HEADBOARD LEG	1
C		FOOTBOARD	1
D		WOODEN SUPPORT	8
E		WOODEN SLAT	4
F		CONCEAL PANEL	4
G		SIDE RAIL A	2
H		SIDE RAIL B	2
I		SIDE RAIL SUPPORT LEG	2

## HARDWARE LIST

ITEM	DRAWING	DESCRIPTION	QTY
1		ALLEN WRENCH (M4)	1
2		WOOD DOWEL (M8 x 30mm)	12
3		CONNECTION BOLT (M6 x 80mm) (FOR HB LEG)	2
4		CONNECTION BOLT (M6 x 45mm) (FOR HB LEG)	8
5		CONNECTION BOLT (M6 x 35mm) (FOR SR)	8
6		CONNECTION BOLT (M6 x 25mm) (FOR HB LEG & SR)	8
7		ROUND HEAD SCREW (M4 x 20mm)	16
8		FLAT HEAD SCREW (#8 x 1 1/8")	8
9		SCREW DRIVER(*)	1

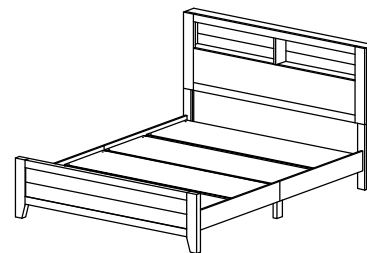

**COMPLETED KING BED  
ASSEMBLY**

The manufacturer does not provide item 9.

## STEP 1

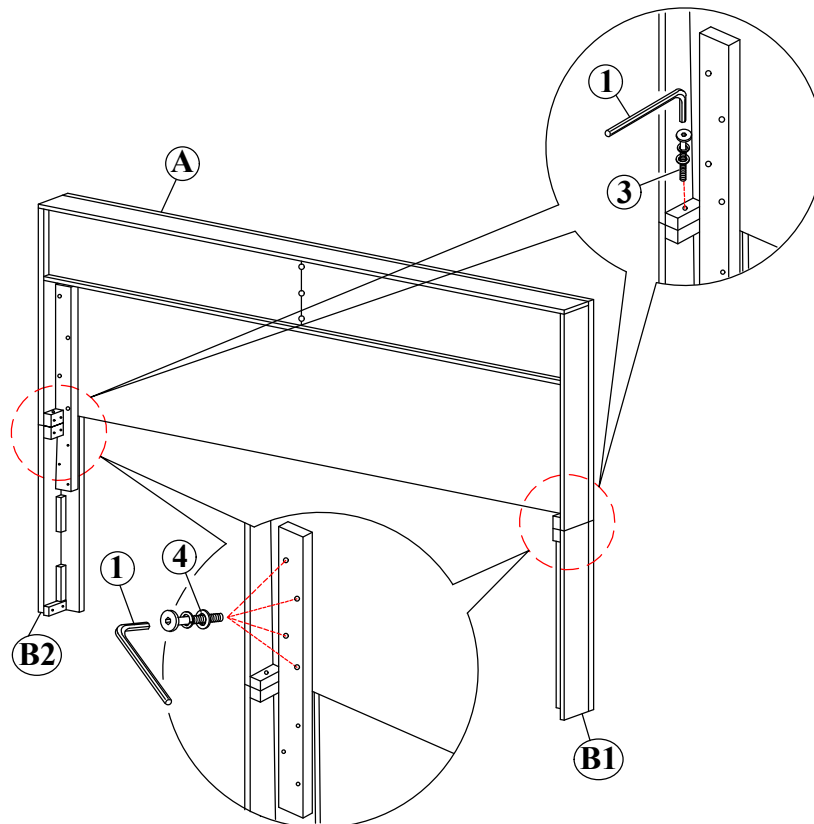

THE HARDWARE IS LOCATED IN THE HARDWARE BAG

NOTE : MUST TIGHTEN SCREWS PERIODICALLY. WITH USE SCREW MAY BECOME LOOSE.  
CHECK TIGHTNESS OF ALL SCREWS EVERY 6-8 WEEKS.

## CLEANING INSTRUCTION

After assembly, clean & polish the completed parts if necessary with soft cloth and industrial recognized furniture polish

# ASSEMBLY INSTRUCTIONS

ITEM NO : B8170 - K - BED  
KING HEADBOARD / FOOTBOARD / SIDE RAIL

## STEP 2

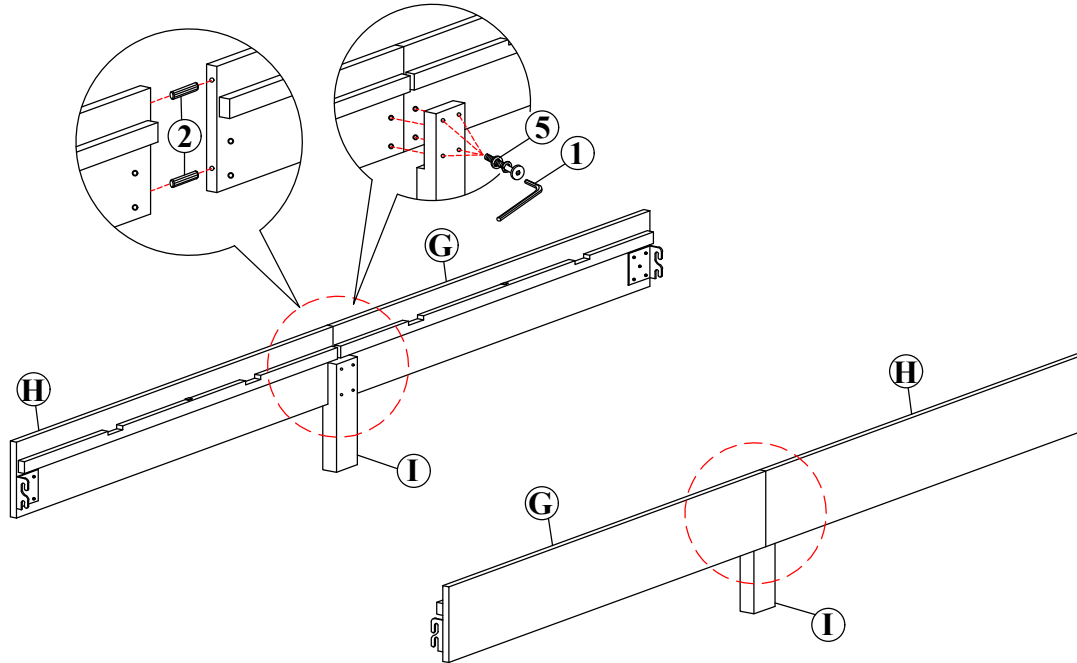

## STEP 3

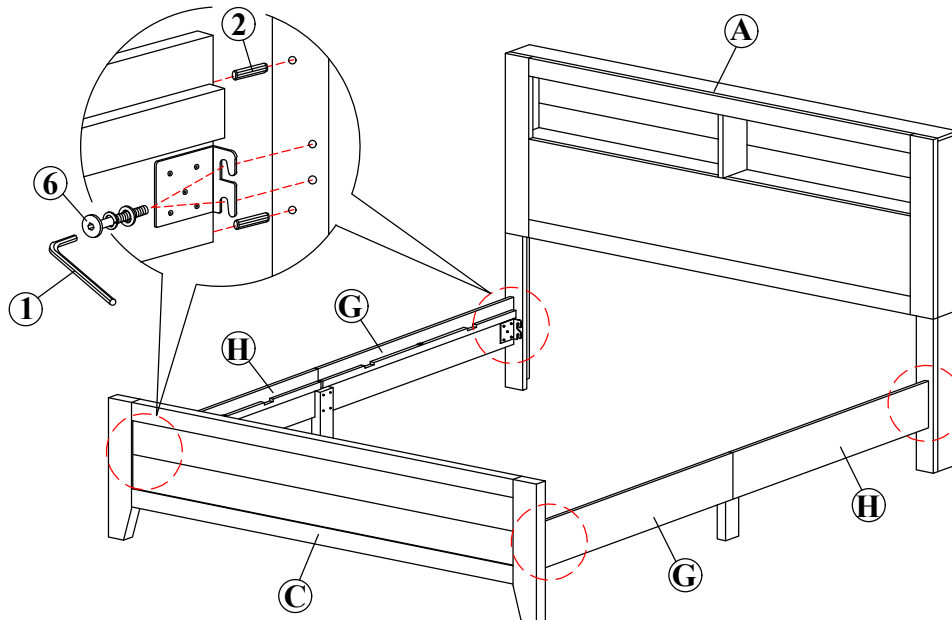

THE HARDWARE IS LOCATED IN THE HARDWARE BAG

NOTE : MUST TIGHTEN SCREWS PERIODICALLY. WITH USE SCREW MAY BECOME LOOSE.  
CHECK TIGHTNESS OF ALL SCREWS EVERY 6-8 WEEKS.

### CLEANING INSTRUCTION

After assembly, clean & polish the completed parts if necessary with soft cloth and industrial recognized furniture polish

MADE IN MALAYSIA

# ASSEMBLY INSTRUCTIONS

ITEM NO : B8170 - K - BED  
KING HEADBOARD / FOOTBOARD / SIDE RAIL

## STEP 4

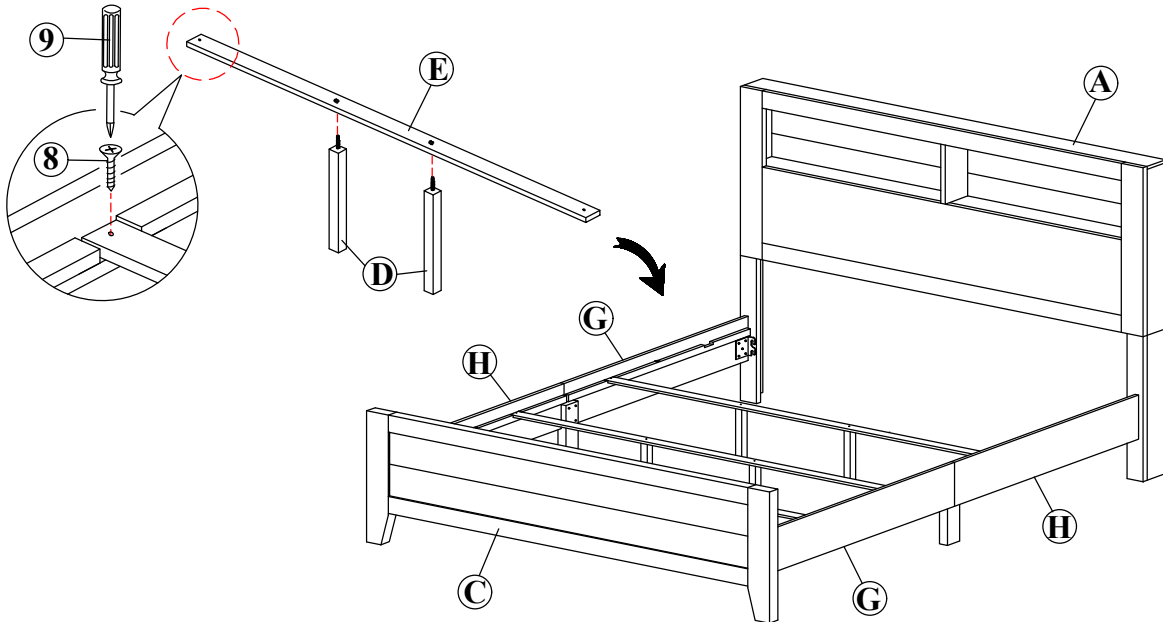

## STEP 5

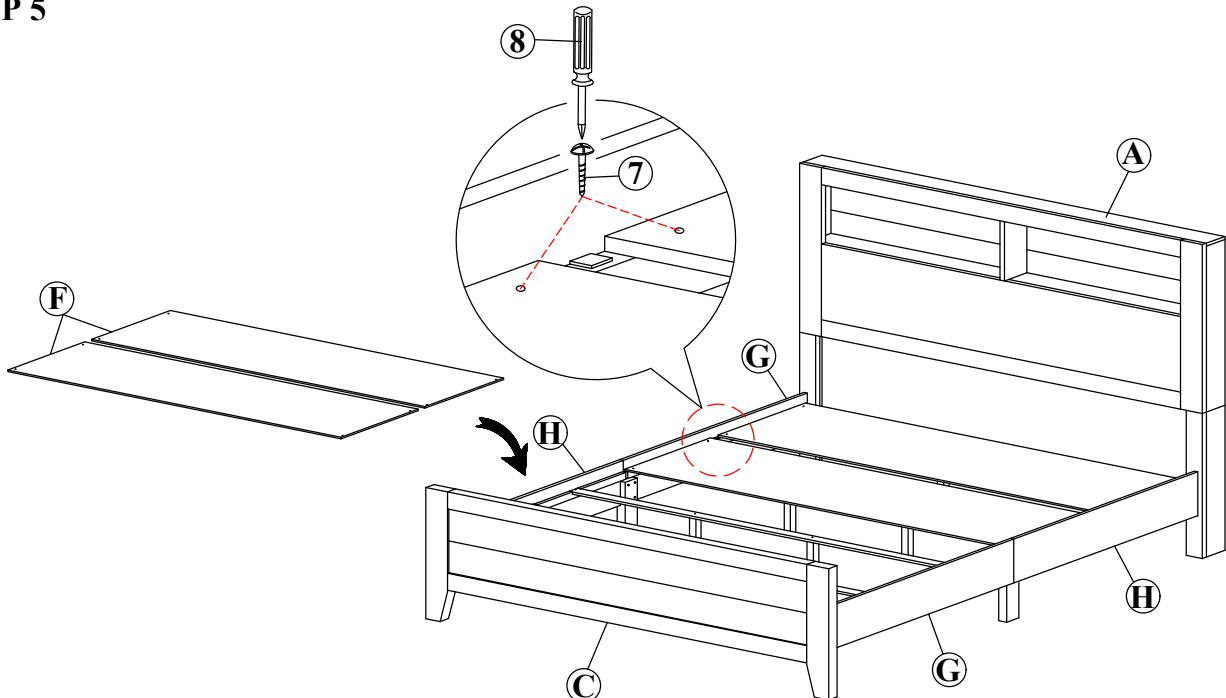

THE HARDWARE IS LOCATED IN THE HARDWARE BAG

NOTE : MUST TIGHTEN SCREWS PERIODICALLY. WITH USE SCREW MAY BECOME LOOSE.  
CHECK TIGHTNESS OF ALL SCREWS EVERY 6-8 WEEKS.

## CLEANING INSTRUCTION

After assembly, clean & polish the completed parts if necessary with soft cloth and industrial recognized furniture polish

MADE IN MALAYSIA