

ASSEMBLY INSTRUCTION



BAR STOOL

ASSEMBLY INSTRUCTIONS

ASSEMBLY TIPS:

1. Remove hardware from box and sort by size.
2. Please check to see that all hardware and parts are present prior to start of assembly.
3. Please follow attached instructions in the same sequence as numbered to assure fast & easy assembly.



Warning!

1. Don't attempt to repair or modify parts that are broken or defective. Please contact the store immediately.
2. This product is for home use only and not intended for commercial establishments.







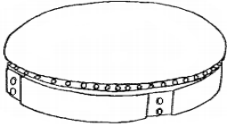
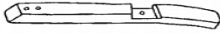
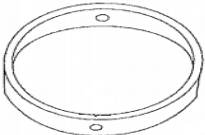

ASSEMBLY TIME

20 MINUTES

PARTS IDENTIFICATION

A	SEAT		1PC	C	LEG		4PCS
B	BASE		1PCS				

HARDWARE IDENTIFICATION

1	WRENCH 4mm		1PC	5	FLAT WASHER#2 1/4"×19mm		8PCS
2	LONG BOTL 1/4"×1-3/4"		8PCS	6	SHORT BOLT 1/4"×1-1/8"		4PCS
3	LOCK WASHER 1/4"×11mm		12PCS	7	ALLEN WRENCH 9mm		4PCS
4	FLAT WASHER#1 1/4"×12mm		4PCS				

NOTE :

PHILLIPS HEAD SCREW DRIVER IS REQUIRED IN THE ASSEMBLY PROCESS;HOWEVER, MANUFACTURER DOES NOT PROVIDE THIS ITEM.

ASSEMBLY INSTRUCTIONS

STEP 1

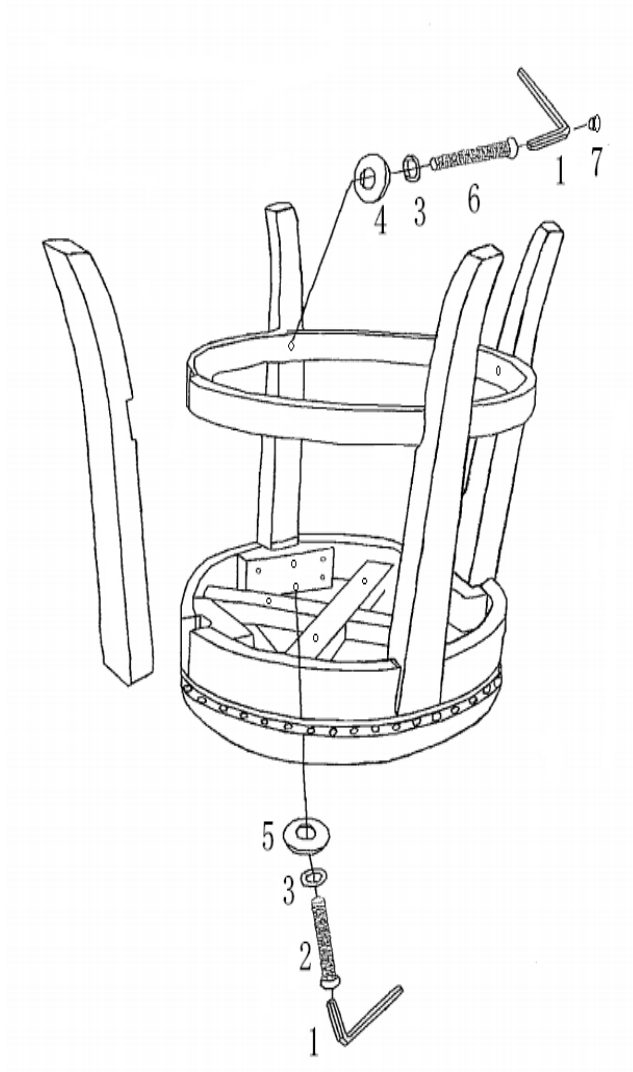

NOTE :

PHILLIPS HEAD SCREW DRIVER IS REQUIRED IN THE ASSEMBLY PROCESS;HOWEVER, MANUFACTURER DOES NOT PROVIDE THIS ITEM.

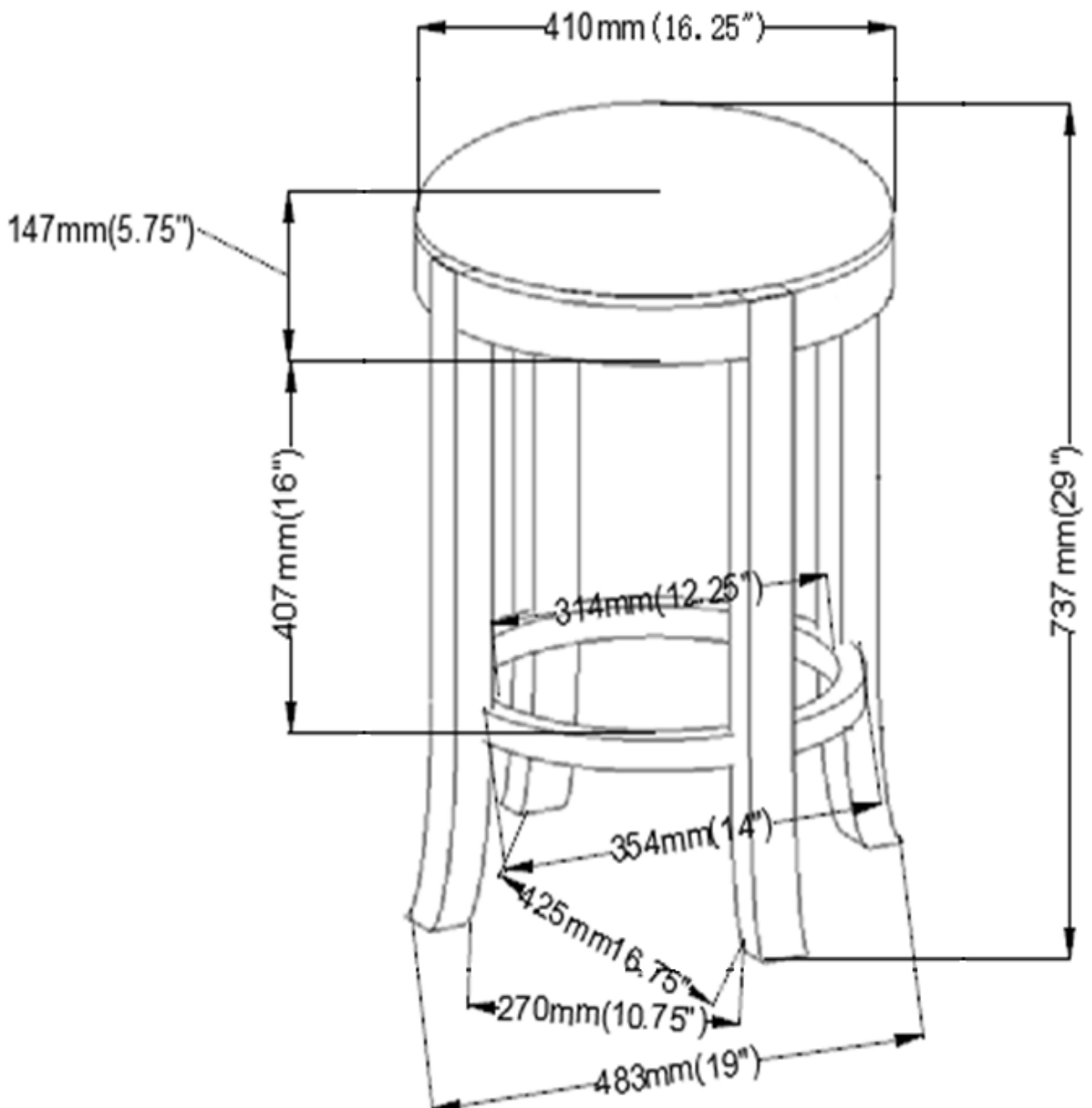

NOTE:

Dimension tolerance $\pm 5\%$