

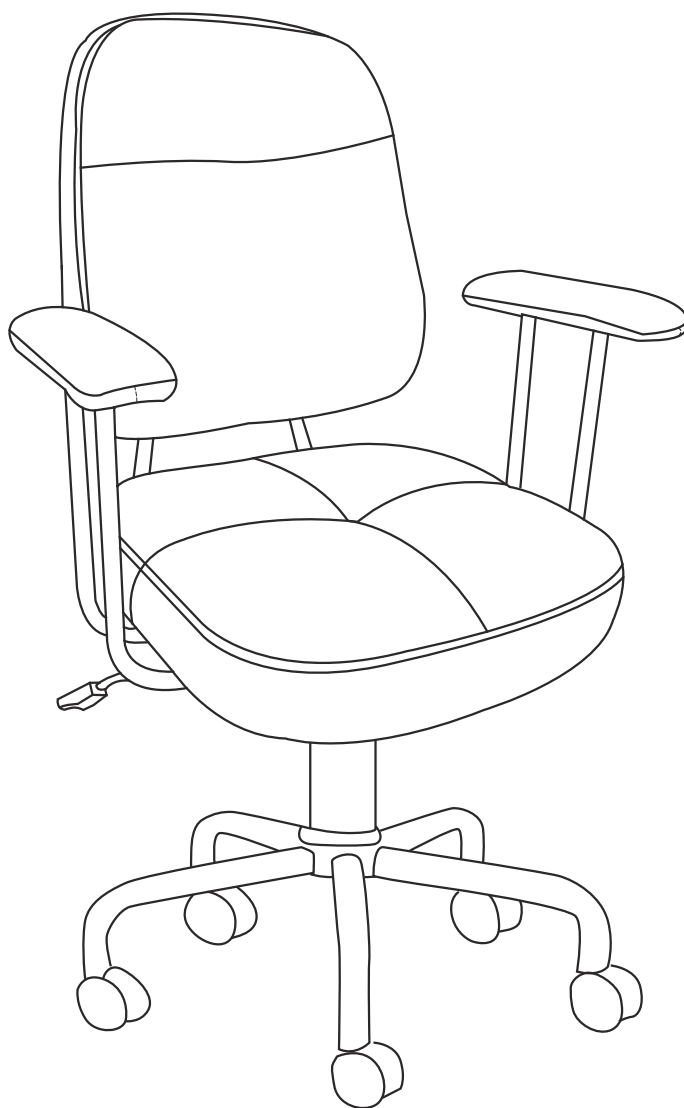

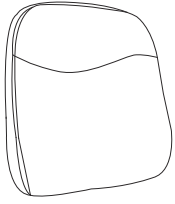

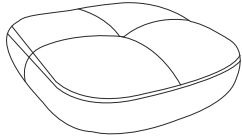

ASSEMBLY INSTRUCTIONS

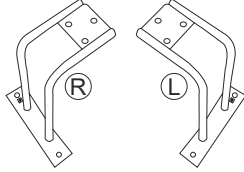
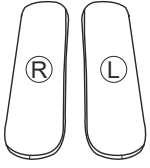
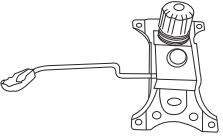

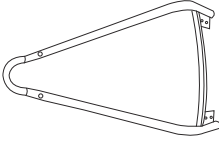



If you need to return the goods, please keep all the packaging materials and return it in the original packaging.
Si vous devez retourner la marchandise, veuillez conserver tous les matériaux d'emballage et le retourner dans l'emballage d'origine.
Si necesita devolver los productos, conserve todos los materiales de embalaje y devuélvalos en el embalaje original.
如需退货请保留好所有包装材料，并按原包装包好退回。

PARTS / PIÈCES / PARTES / 部件清单

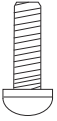
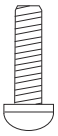
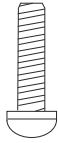
 <p>X1</p> <p>OC33-BR-GY/OC33-BR-BR</p> <p>(P1)</p>	 <p>X1</p> <p>OC33-SB-GY/OC33-SB-BR</p> <p>(P2)</p>	 <p>X1</p> <p>OC33-AR-GY/OC33-AR-BR</p> <p>(P3)</p>	 <p>X1</p> <p>OC33-AR-GY/OC33-AR-BR</p> <p>(P4)</p>
 <p>X1</p> <p>OC33-TM</p> <p>(P5)</p>	 <p>X1</p> <p>OC33-CY</p> <p>(P6)</p>	 <p>X1</p> <p>OC33-BIF</p> <p>(P7)</p>	 <p>X1</p> <p>OC33-WB</p> <p>(P8)</p>
 <p>X5</p> <p>OC33-WB</p> <p>(P9)</p>	 <p>X5</p> <p>OC33-CT</p> <p>(P10)</p>		

HARDWARE / MATÉRIEL / HARDWARE / 配件清单

<p>M6*14X5</p>  <p>(A)</p>	<p>M6*18X4</p>  <p>(B)</p>	<p>M6*20X14</p>  <p>(C)</p>	<p>M6*35X2</p>  <p>(D)</p>	<p>X14</p>  <p>(E)</p>	<p>X1</p>  <p>(D)</p>
---	---	--	---	---	--

ASSEMBLY INSTRUCTIONS

INSTRUCTIONS DE MONTAGE

INSTRUCCIONES DE MONTAJE

安装说明

STEP 1

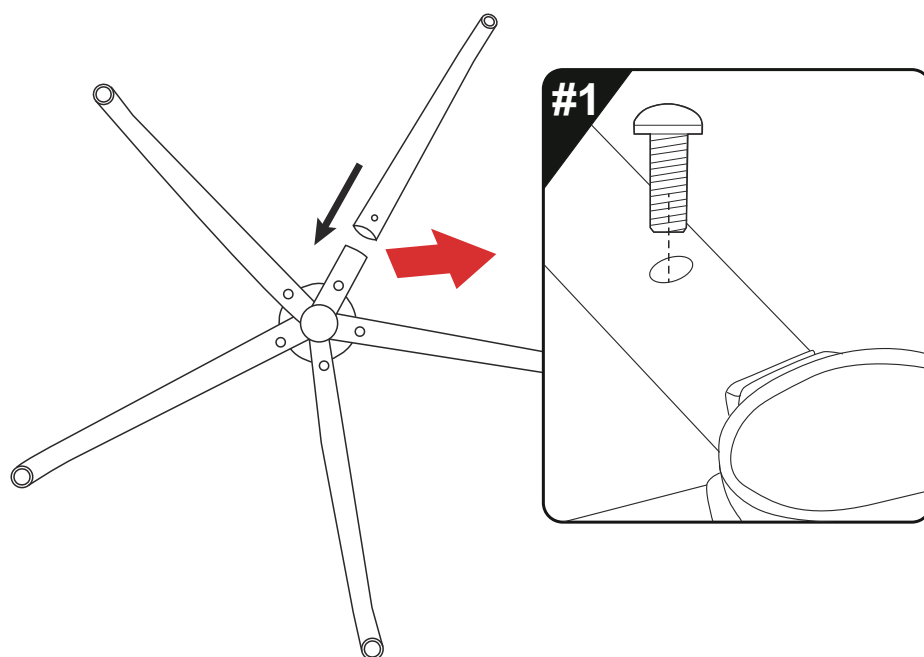
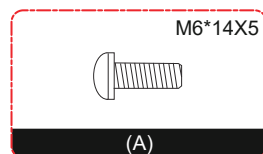
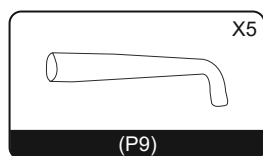
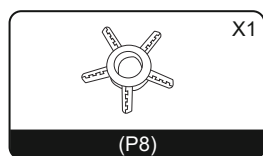

STEP 2

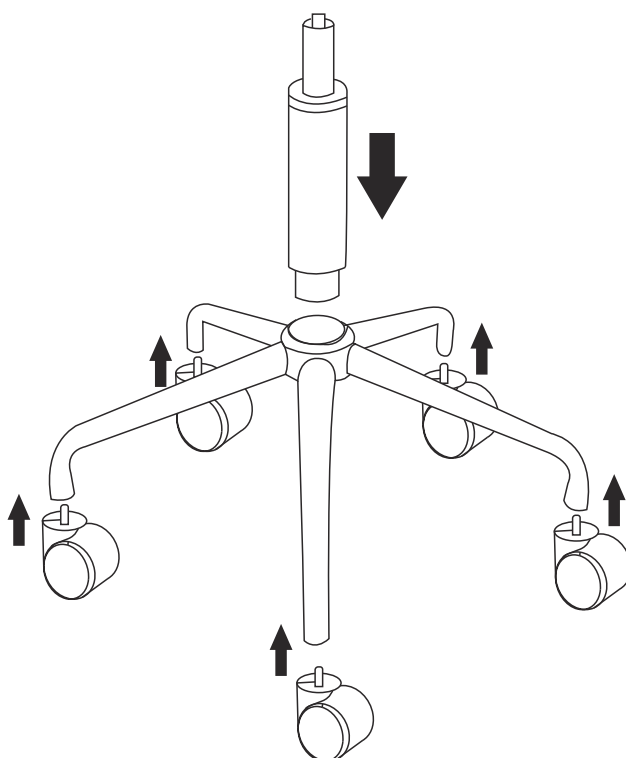
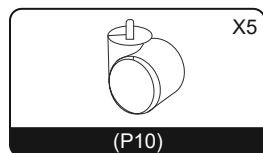
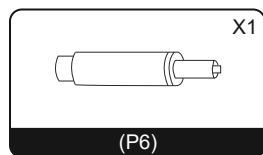

STEP 3

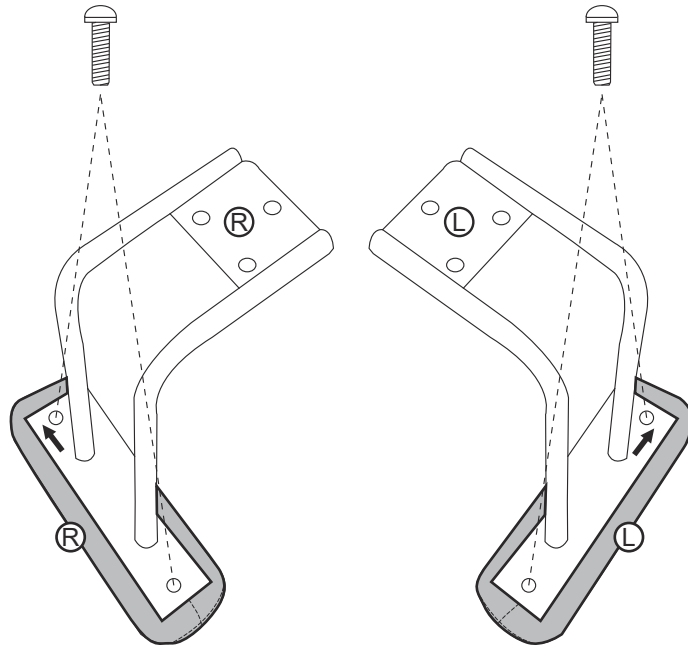
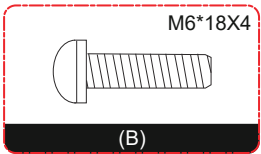
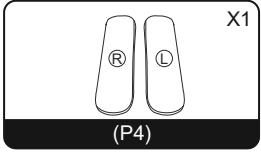
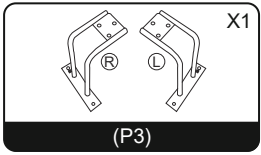

STEP 4

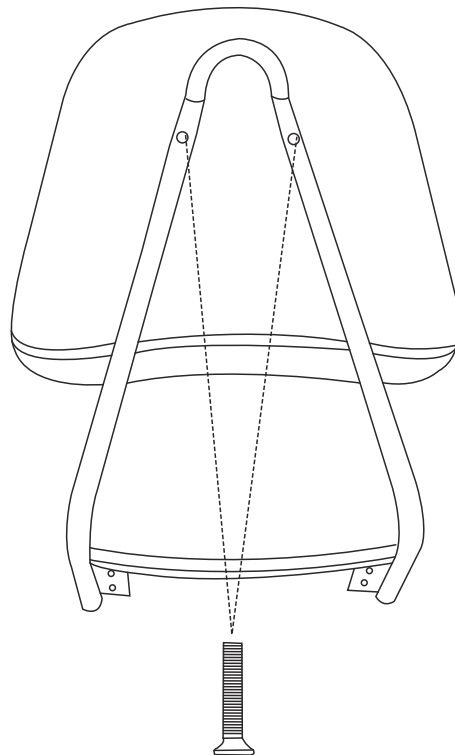
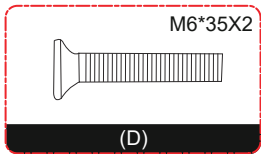
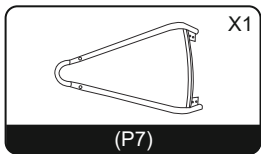
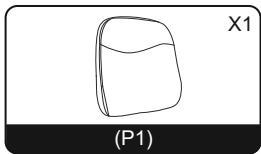

STEP 5

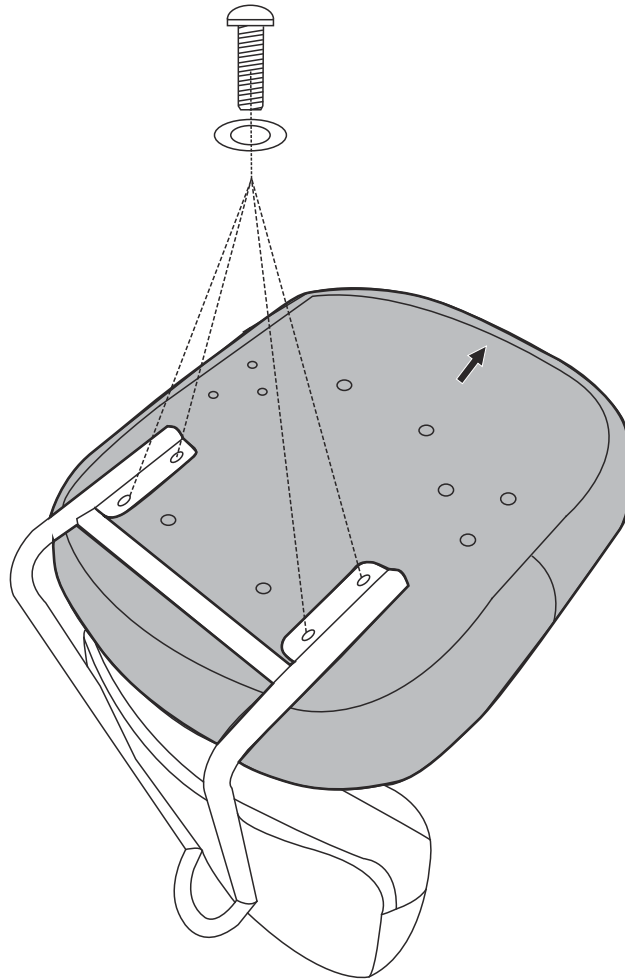
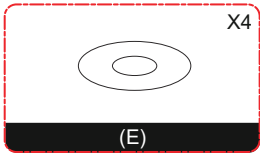
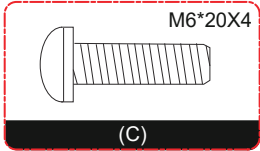
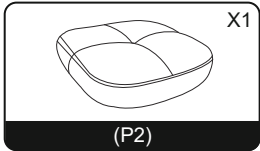

STEP 6

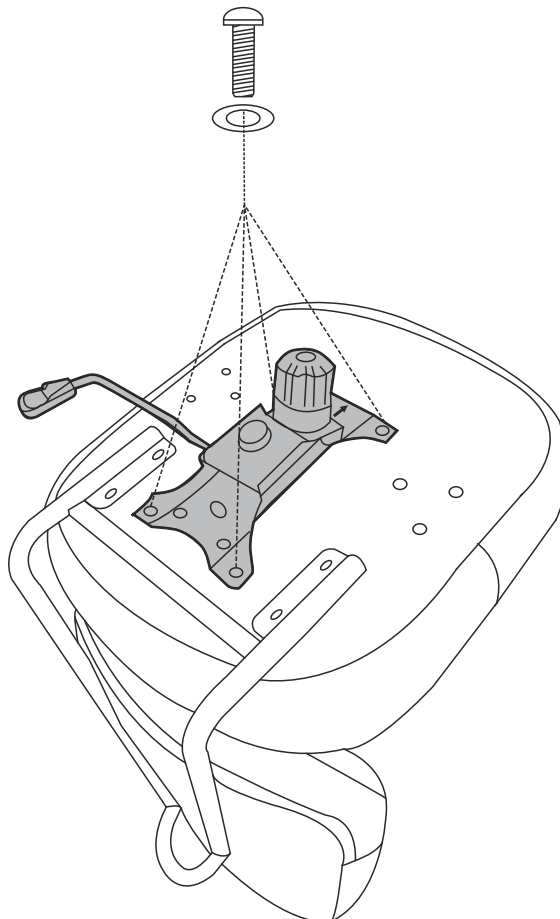
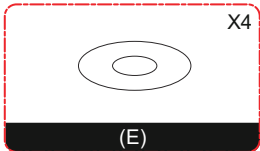
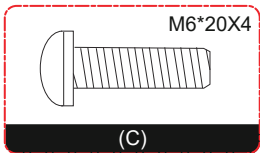
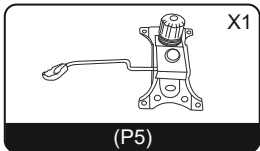

STEP 7

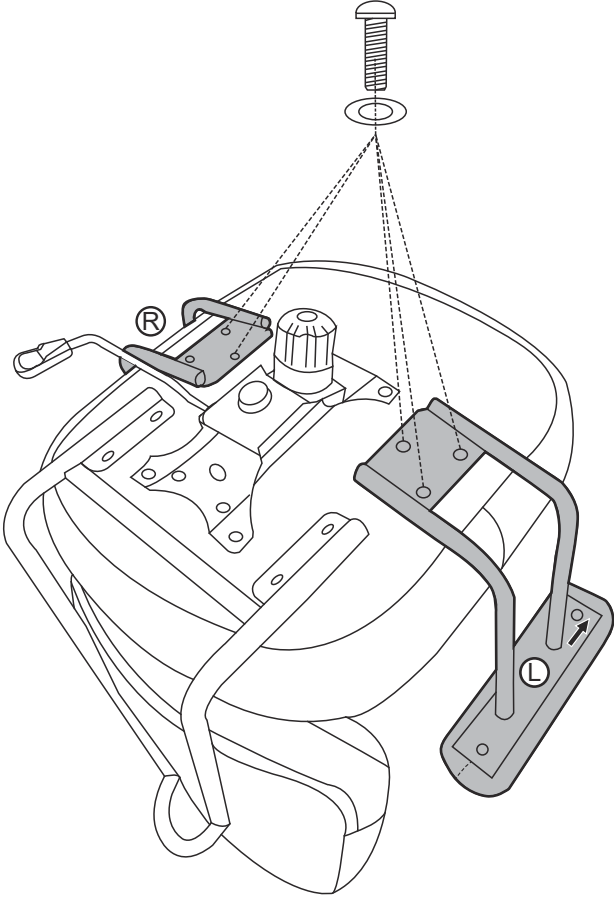
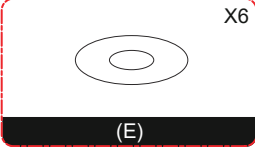
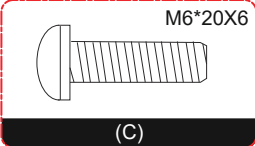

STEP 8

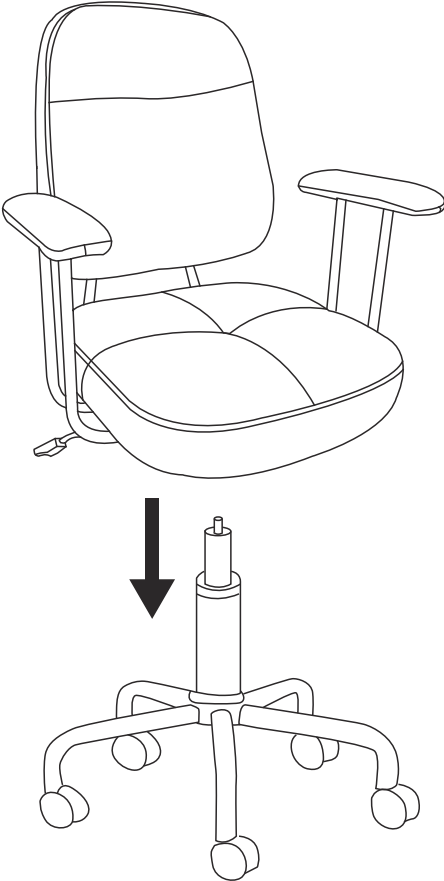

INSTRUCTIONS FOR USE

MODE D'EMPLOI

INSTRUCCIONES DE USO

使用说明

To rise the seat height, pull this lever up (No need to be seated). To lower down the seat height, pull this lever up again (Sitting is necessary).

Tilt function: Pull the lever outward, the backrest can realize the tilt function, push the lever inward, lock the backrest.

Pour augmenter la hauteur du siège, remontez ce levier (pas besoin d'être assis). Pour abaisser la hauteur du siège, retirez ce levier vers le haut (assis est nécessaire).

Fonction d'inclinaison : Tirer le levier vers l'extérieur, le dossier peut réaliser la fonction d'inclinaison, pousser le levier vers l'intérieur, bloquer le dossier.

Para elevar la altura del asiento, tire de esta palanca (no es necesario sentarse). Para bajar la altura del asiento, tire de esta palanca nuevamente (es necesario sentarse).

Función de inclinación: Tire de la palanca hacia fuera, el respaldo puede realizar la función de inclinación, empuje la palanca hacia dentro, bloquee el respaldo.

座椅高度调节：把这个杆子往上拉（不需要坐着），降低座椅高度，再次拉动这个杆子（必须坐着）。

倾仰功能：杆子往外拉，靠背可实现倾仰功能，杆子往里推，锁定靠背。

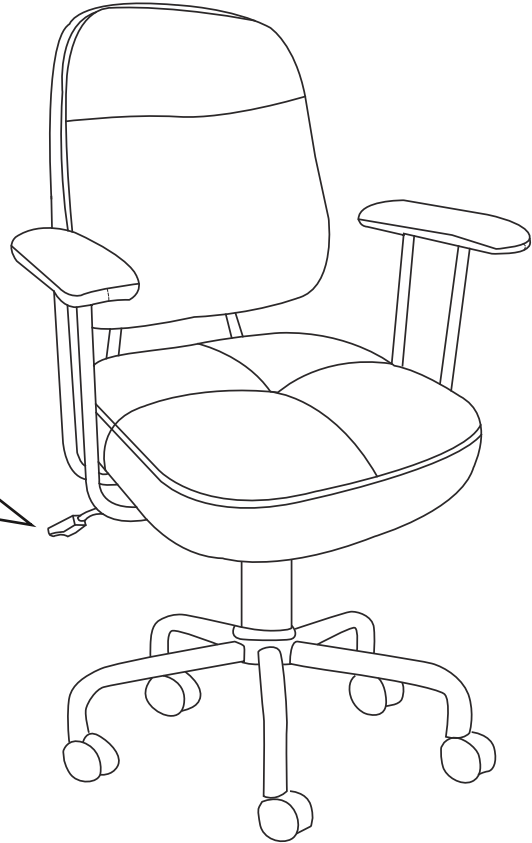

Loosen the backrest clockwise (when seated) and tighten it counterclockwise (when seated).

Desserer le dossier dans le sens des aiguilles d'une montre (en position assise) et le resserrer dans le sens inverse des aiguilles d'une montre (en position assise).

Afloje el respaldo en el sentido de las agujas del reloj (cuando está sentado) y apriételo en el sentido contrario (cuando está sentado).

顺时针（坐着时）调松靠背，逆时针方向（坐着时）收紧靠背。