

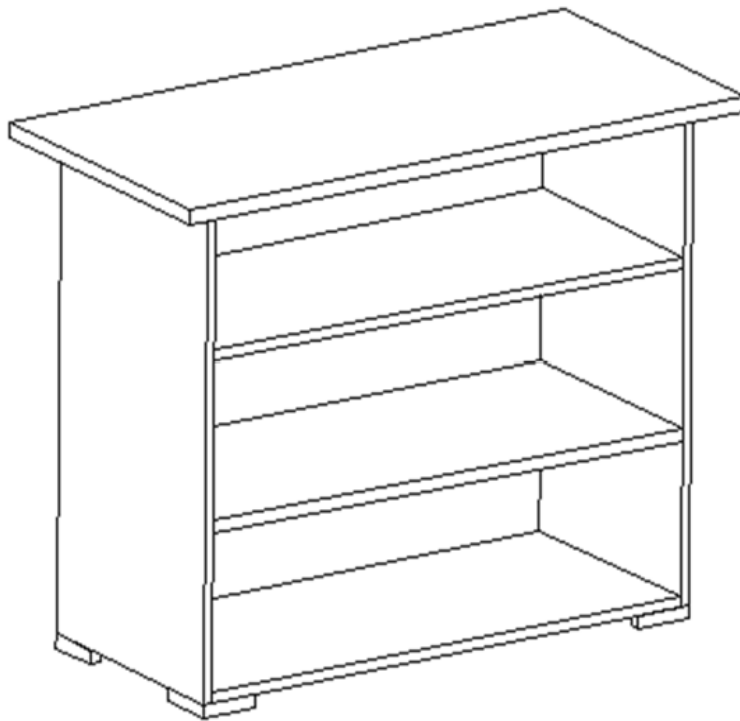

# Assembly Instructions





**Caution : You must read this before you proceed**

## Shelf

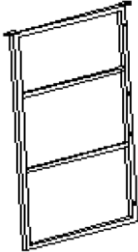

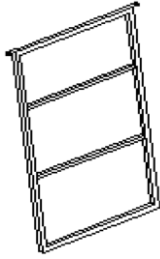
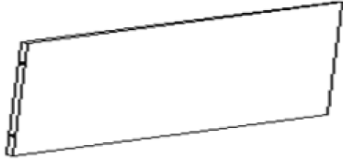
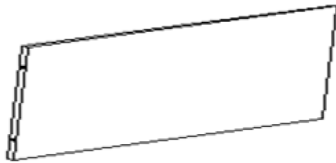

### Parts List

Label	Picture	Description	QTY
A		Top of Shelf	1
B		Left Panel	1

C		Right Panel	1
D		Top Back Panel	1
E		Bottom Back Panel	1
F		Shelf	2
G		Bottom Plate	1
H		Feet Cap	4

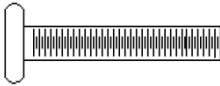
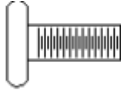
## Hardware

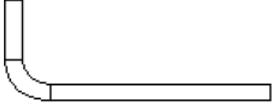
Label	Picture	Description	QTY
①		Bolt M6*45mm	21
②		Bolt M6*20mm	5
③		Spring washer	25
④		Allen Key	1

# Assembly Preparation

Before Beginning  
Assembly:

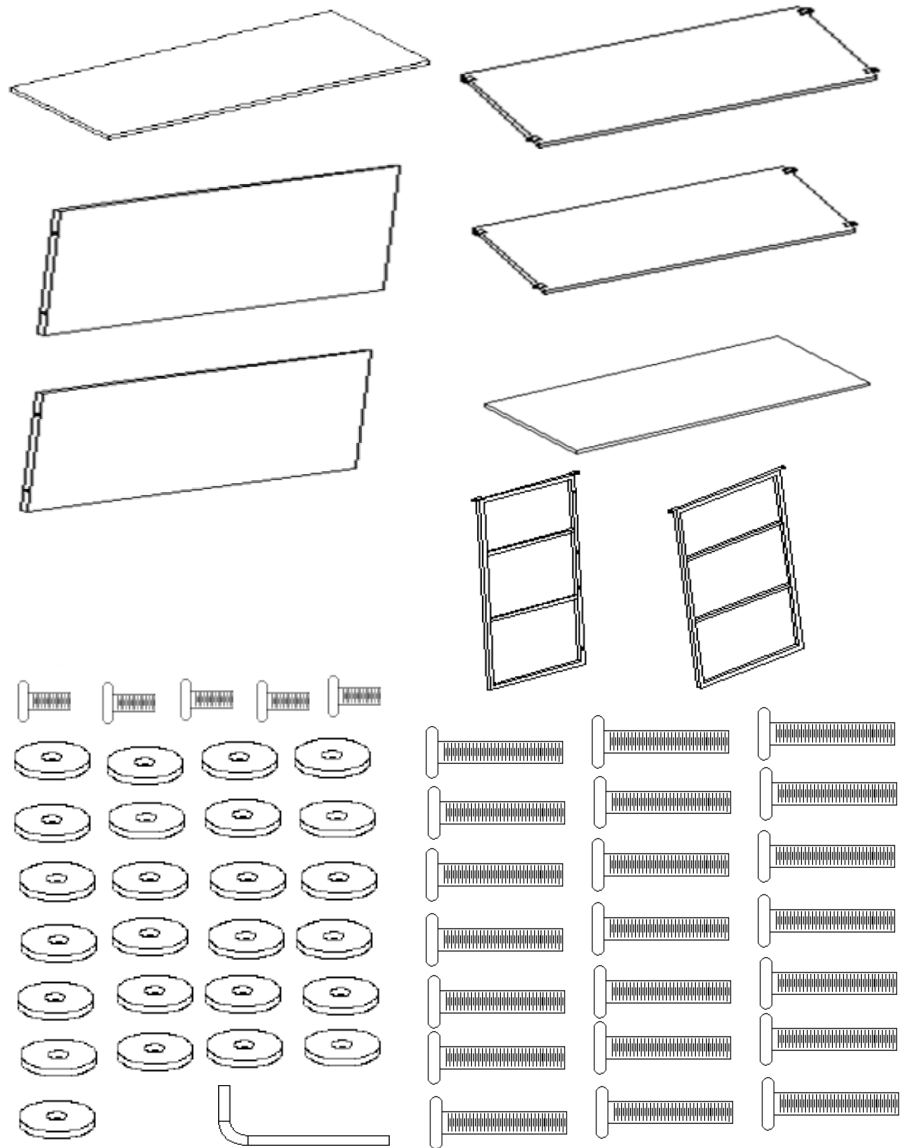

- Read instructions, cover to cover-



- Have 2 adults on hand for assembly-



- Do not assemble on flooring or carpet-



- Assemble on a clean non-marring surface (packing foam)-



- Save all packaging until finished-

# Assembly Steps

## Overview

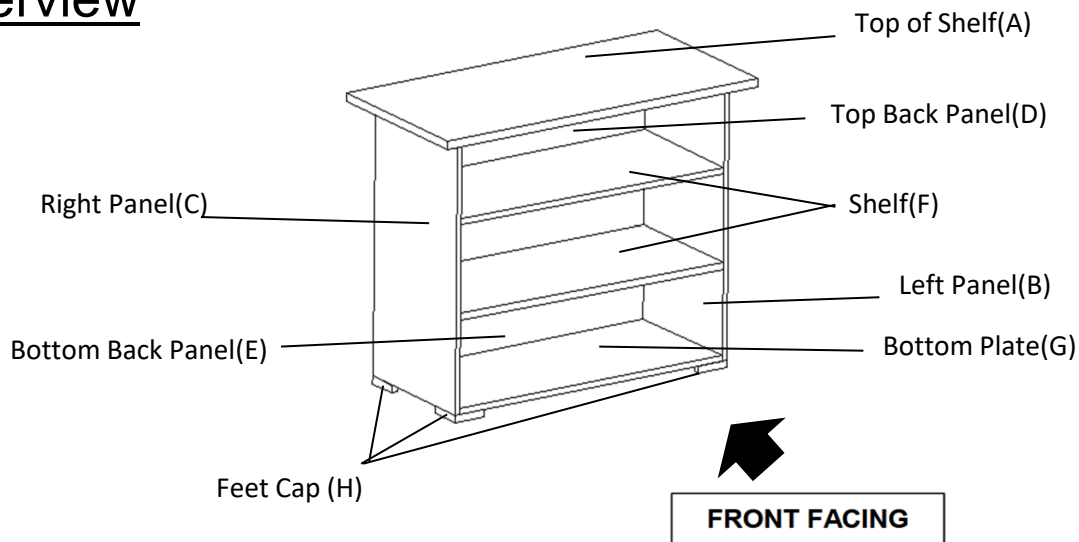

This Shelf has multiple parts and may require up to some 30 minutes to assemble. To give you an overview of the Shelf parts, the above picture is to help you put the various parts into perspective. Please read through the instructions here below to familiarise yourself with the parts and steps before assembly.

## Step 1

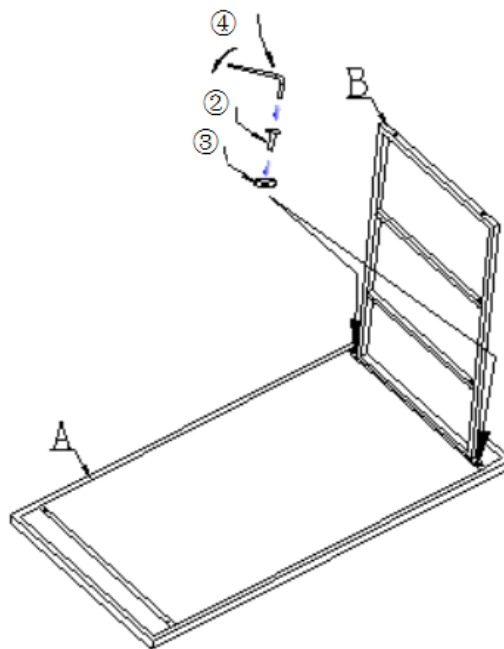

Open the carton and place all the parts onto a clean and soft surface.  
Unpack all packages of hardware.  
Then place Shelf Top (A) facedown on a clean, non-marring surface.  
Attach the Left Panel (B) to the Table Top (A) using hardware(③,②) with Allen Key(④).  
**DO NOT FULLY TIGHTEN THE BOLTS.**

## Step 2

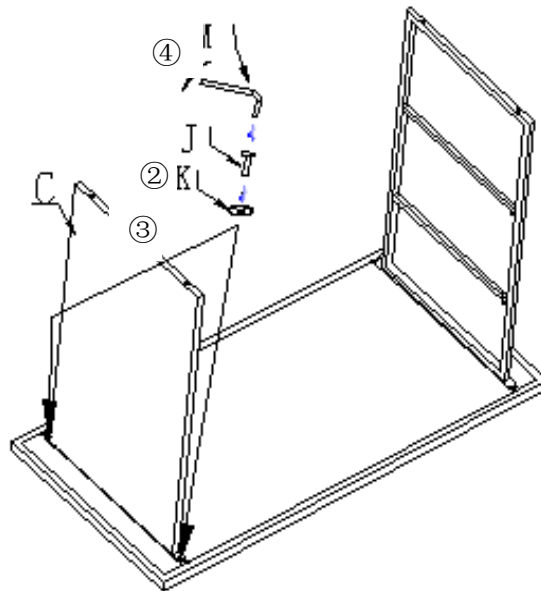

Repeat Step 1 attaching the Right Panel(C) to the Shelf Top(A).  
**DO NOT FULLY TIGHTEN THE BOLTS.**

## Step3

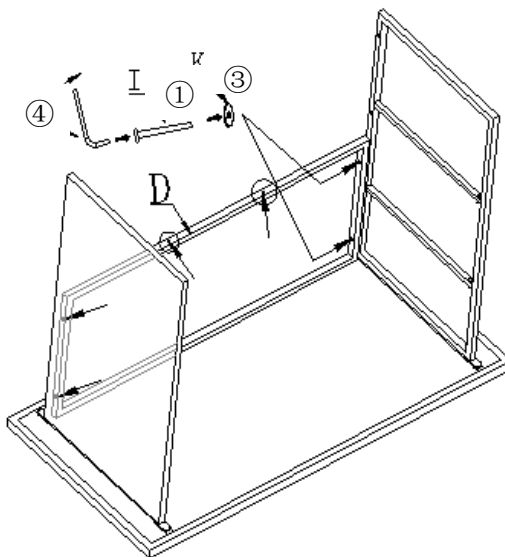

Attach the Top Back Panel(D) between the side panels using hardware (③, ①) with Allen Key (④).

The bolts mounting position on long side of the Top Back Panel(D) should be on the upside.  
**DO NOT FULLY TIGHTEN THE BOLTS.**

## Step 4

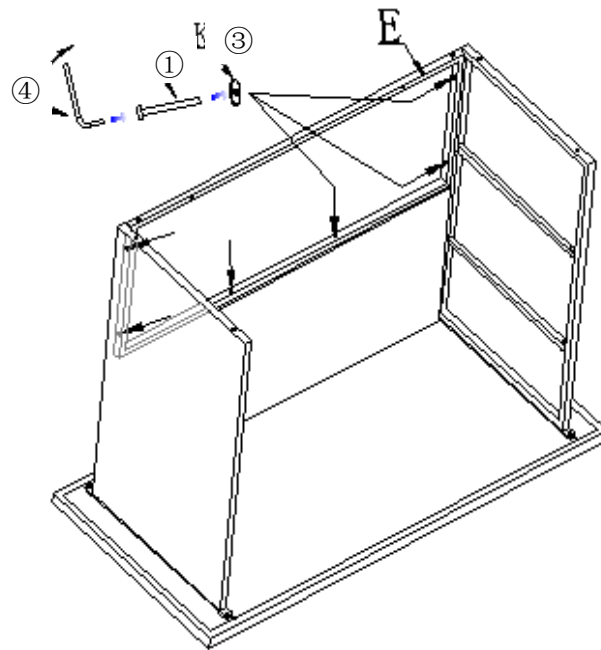

Attach the Bottom Back Panel(E) between the side panels using hardware(③, ①) with Allen Key(④).

**DO NOT FULLY TIGHTEN THE BOLTS.**

## Step 5

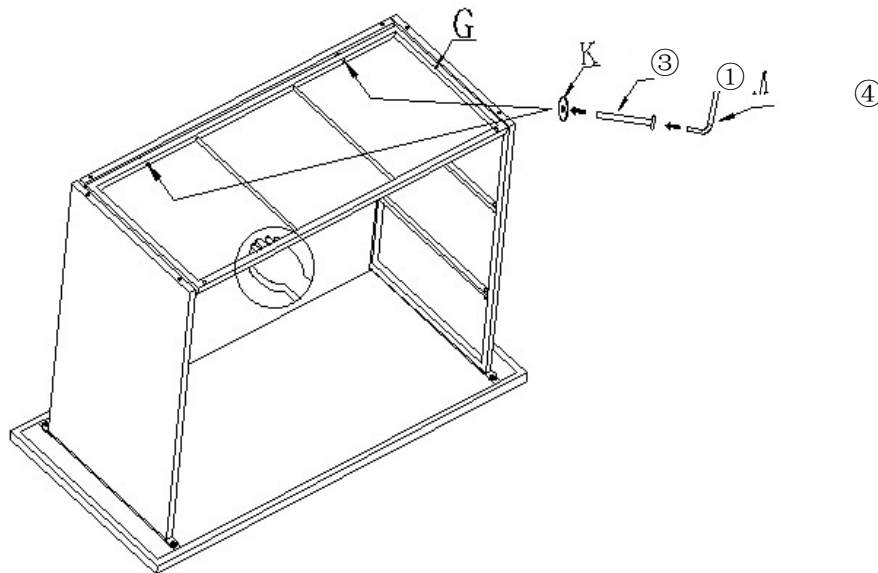

**NOTE: Please have a second adult help you perform the Step 5 & Step 6.**

Attach the Bottom Plate(G) to the Bottom Back Panel(E) using hardware(③, ①) with Allen Key(④).

**DO NOT FULLY TIGHTEN THE BOLTS.**

## Step 6

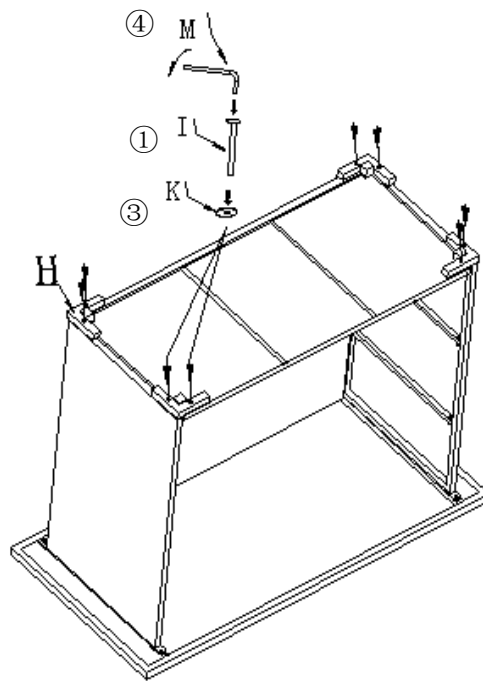

Attach the Feet Cap(H) to the Bottom Plate(G) using hardware(③, ①) with Allen Key(④).  
Now, in a gradual and sequential manner, **proceed to fully and securely tighten all Bolts at all joints.**

## Step 7

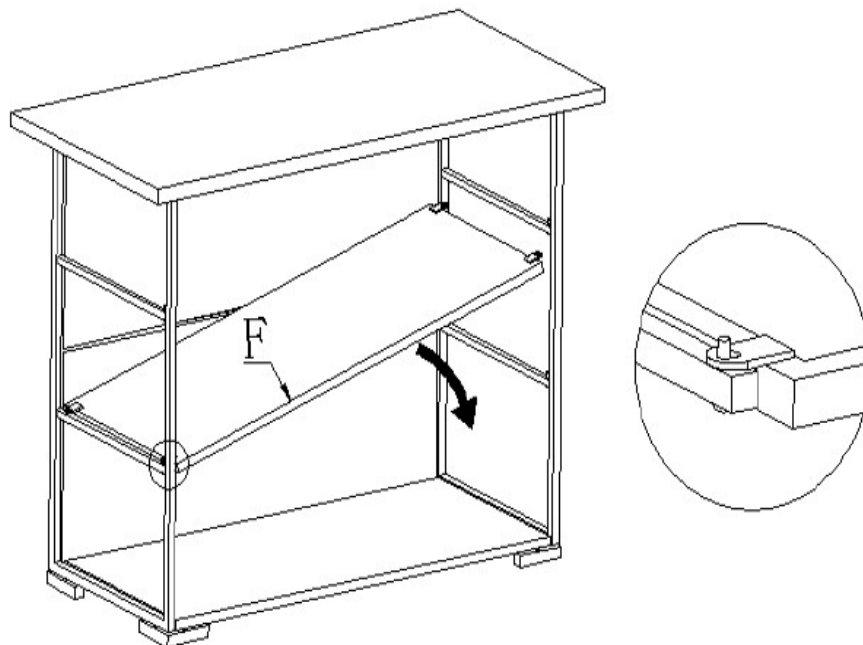

To install the Shelves(F), first place the loop attached to the left side of the shelf into the metal peg on the inside of the Left Side Panel(B) as shown in the picture above.  
Then lower the right side until the loops fit into the pegs on the right side.

## Step 8

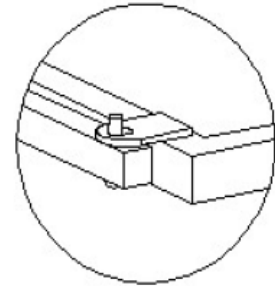
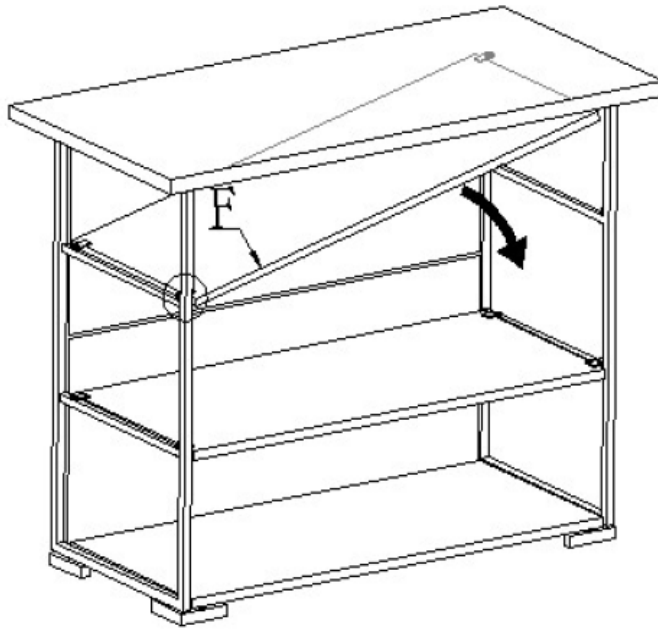





















Repeat Step 7 to install the second Shelf(F).  
The Shelf is ready for use.

**The Shelf can only be used on a flat, level surface.**



## Care & Maintenance

-   ● Do not put hot items directly on furniture surface
  -   ● Do not clean furniture with harsh cleansers or polish.
  -   ● To obtain the longest lifespan of your outdoor products, minimizing exposure to direct sunlight is recommended.
  -   ● Children should not climb or jump on the furniture.
  -   ● Do not write on furniture without a padded barrier to protect the surface.
  -   ● To obtain the longest lifespan of your outdoor products, avoid extended and lengthy exposure to rain, snow, and direct sunshine. Whenever possible cover the product and /or place under patio or awnings.
  -   ● Not for commercial use. For residential use only .
  -   ● Stains may be removed with mild soap solution and damp cloth.
  -   ● Keep away from sources of ignition.
- 
-   ● Dust and pick-up spills using a clean, non-colored, lint-free cloth.

### Questions & Answers about Proposition 65

#### • What is Proposition 65?

Proposition 65 requires businesses to provide warnings to Californians about significant exposures to chemicals that cause cancer, birth defects or other reproductive harm. These chemicals can be in the products that Californians purchase, in their homes or workplaces, or that are released into the environment. By requiring that this information be provided, Proposition 65 enables Californians to make informed decisions about their exposures to these chemicals.

Proposition 65 also prohibits California businesses from knowingly discharging significant amounts of listed chemicals into sources of drinking water.

Proposition 65 requires California to publish a list of chemicals known to cause cancer, birth defects or other reproductive harm. This list, which must be updated at least once a year, has grown to include approximately 900 chemicals since it was first published in 1987.

#### • What types of chemicals are on the Proposition 65 list?

The list contains a wide range of naturally occurring and synthetic chemicals that include additives or ingredients in pesticides, common household products, food, drugs, dyes, or solvents. Listed chemicals may also be used in manufacturing and construction, or they may be byproducts of chemical processes, such as motor vehicle exhaust.

#### • What does a warning mean?

If a warning is placed on a product label or posted or distributed at a workplace, a business, or in rental housing, the business issuing the warning is aware or believes that it is exposing individuals to one or more listed chemicals.

By law, a warning must be given for listed chemicals unless the exposure is low enough to pose no significant risk of cancer or is significantly below levels observed to cause birth defects or other reproductive harm.

#### • Where can I get more information on Proposition 65?

If you have specific questions on the administration or implementation of Proposition 65, you can contact OEHHA's Proposition 65 program at [P65.Questions@oehha.ca.gov](mailto:P65.Questions@oehha.ca.gov), or by phone at (916) 445-6900.