

ASSEMBLY INSTRUCTIONS COASTER FINE FURNITURE



Fine Furniture for every stage of life



ASSEMBLY INSTRUCTIONS

ASSEMBLY TIPS:

1. Remove hardware from box and sort by size.
2. Please check to see that all hardware and parts are present prior to start of assembly.
3. Please follow attached instructions in the same sequence as numbered to assure fast & easy assembly.



WARNING!



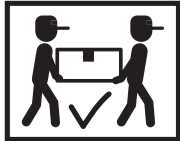





1. Don't attempt to repair or modify parts that are broken or defective. Please contact the store immediately.
2. This product is for home use only and not intended for commercial establishments.

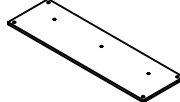
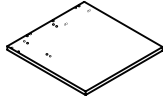

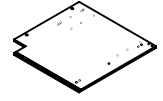
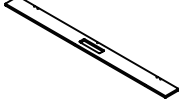
ASSEMBLY TIME

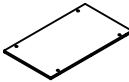
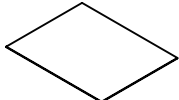
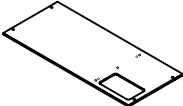
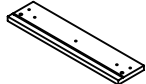
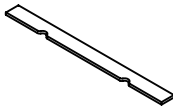
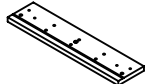
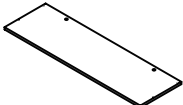

90 MINUTES

PARTS IDENTIFICATION

A	LEFT SIDE PANEL		1 PC	J	LARGE RIGHT BACK PANEL		1 PC
B	RIGHT SIDE PANEL		1 PC	K	SUPPORT PANEL		1 PC
C	MIDDLE DIVIDER PANEL		1 PC	L	BACK BOTTOM BOARD		1 PC
D	CROSS BRACE		1 PC	M	UPPER BACK PANEL		1 PC
E	BOTTOM PANEL		1 PC	N	LARGE LEFT BACK PANEL		1 PC
F	LARGE TOP PANEL		1 PC	O	MIDDLE DRAWER FRONT PANEL		1 PC
G	SMALL TOP PANEL		1 PC	P	UPPER DRAWER FRONT PANEL		1 PC
H	KEYBOARD SHELF		1 PC	Q	MIDDLE DRAWER BACK PANEL		1 PC
I	KEYBOARD FRONT CROSS BAR		1 PC	R	UPPER DRAWER BACK PANEL		1 PC



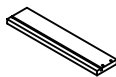
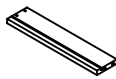
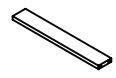
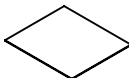



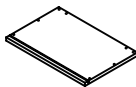
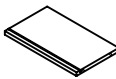
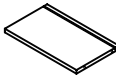
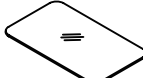



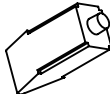

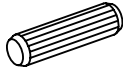

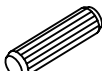
NOTE:

Phillips head screw driver is required in the assembly process; however, manufacturer does not provide this item.

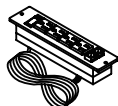
S	LEFT DRAWER SIDE PANEL		2 PCS
T	RIGHT DRAWER SIDE PANEL		2 PCS
U	DRAWER SUPPORT		3 PCS
V	DRAWER BOTTOM PANEL		3 PCS
W	LARGE DRAWER FRONT PANEL		1 PC



X	LARGE DRAWER BACK PANEL		1 PC
Y	LEFT DRAWER SIDE PANEL		1 PC
AA	RIGHT DRAWER SIDE PANEL		1 PC
AB	TOP GLASS		1 PC

HARDWARE IDENTIFICATION

NO	DESCRIPTION	FIGURE	Q'TY	NO	DESCRIPTION	FIGURE	Q'TY
1	GLUE 40g		1 PC	9	HINGE SCREW Ø 4x15mm SR		10 PCS
2	LARGE WOODEN DOWEL Ø 8x30mm		44 PCS	10	PLASTIC FEET Ø 15mm		6 PCS
3	SMALL WOODEN DOWEL Ø 6x25mm		12 PCS	11	HANDLE L = 400mm		3 PCS
4	CAM LOCK Ø 15x12mm SR		24 PCS	12	HANDLE BOLT Ø 4x23mm SR		9 PCS
5	CAM BOLT Ø 7x35.5mm SR		24 PCS	13	POWER OUTLET		1 PC
6	GLIDES SCREW Ø 3x12mm SR		36 PCS	14	HINGE Ø 26mm SR		2 PCS
7	SCREW Ø 4.5x42mm SR		6 PCS	15	GLIDES L = 350mm WHT		3 SET
8	SCREW Ø 4.3x35mm SR		12 PCS	16	RAIL L = 300mm WHT		1 SET

HARDWARE IDENTIFICATION

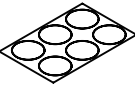
Z

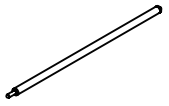
NO	DESCRIPTION	FIGURE	Q'TY	NO	DESCRIPTION	FIGURE	Q'TY
17	RAIL SCREW Ø 3.5x14.5mm SR		12 PCS	19	STICKER Ø 20mm		4 PCS
18	SCREW DRIVER 60x31mm SR		1 PC	20	IRON BAR Ø 9.5x352mm SR		2 PCS

Z11,Z12,Z13,Z14,Z15,Z16,Z17,Z20 not included in blister packaging.

STEP 1

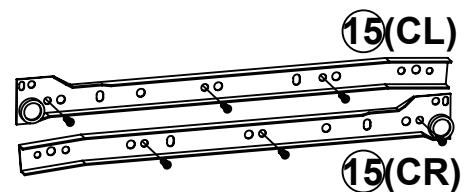
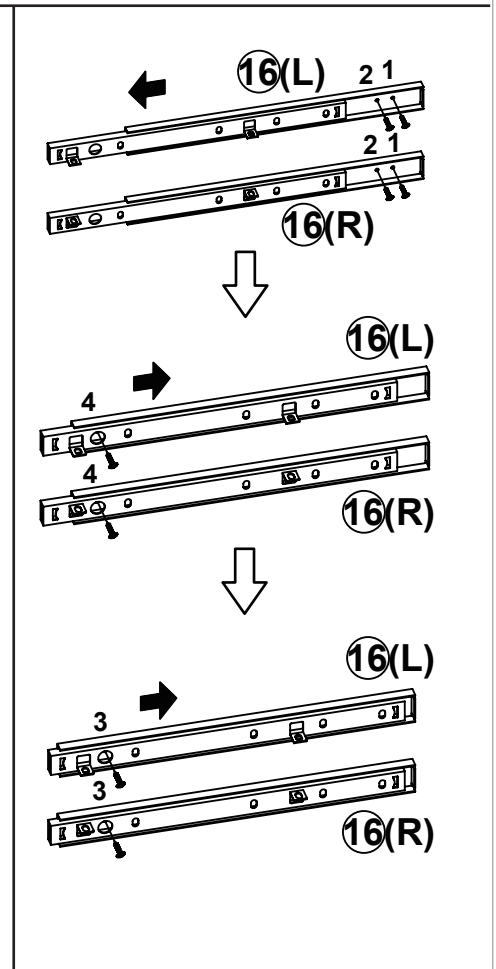
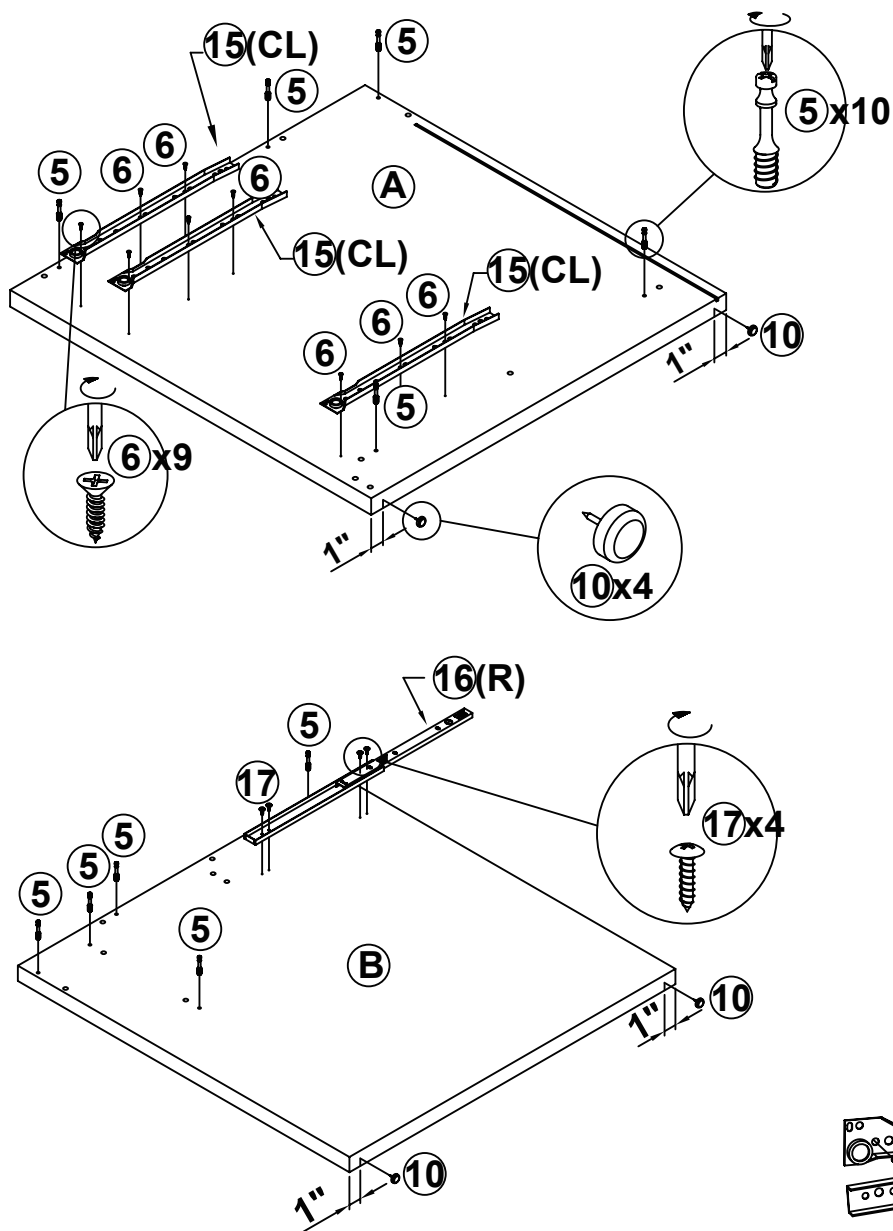

NOTE:

Phillips head screw driver is required in the assembly process; however, manufacturer does not provide this item.

STEP 2

The Glue (1) should be used in the indicated locations to help solidify the assembled unit.

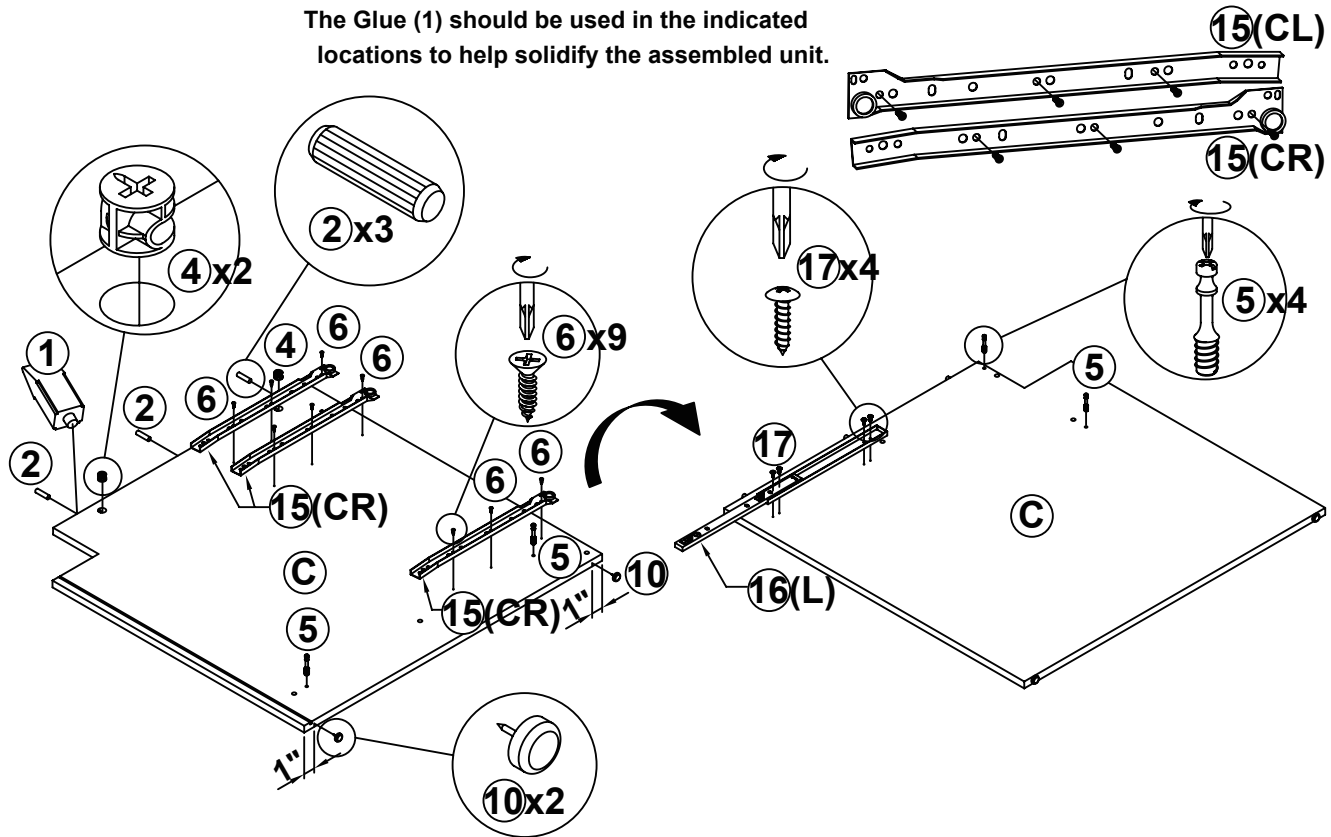

STEP 3

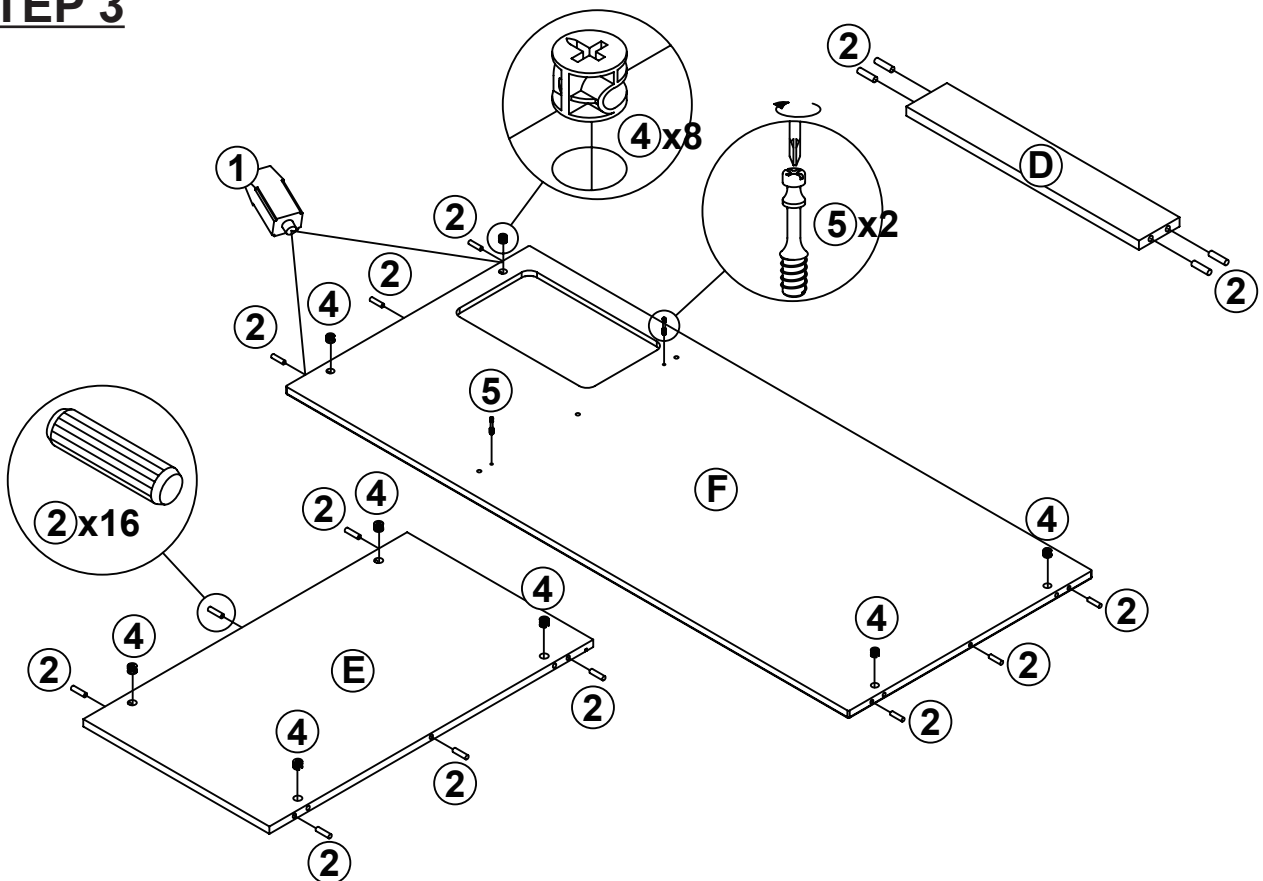

STEP 4

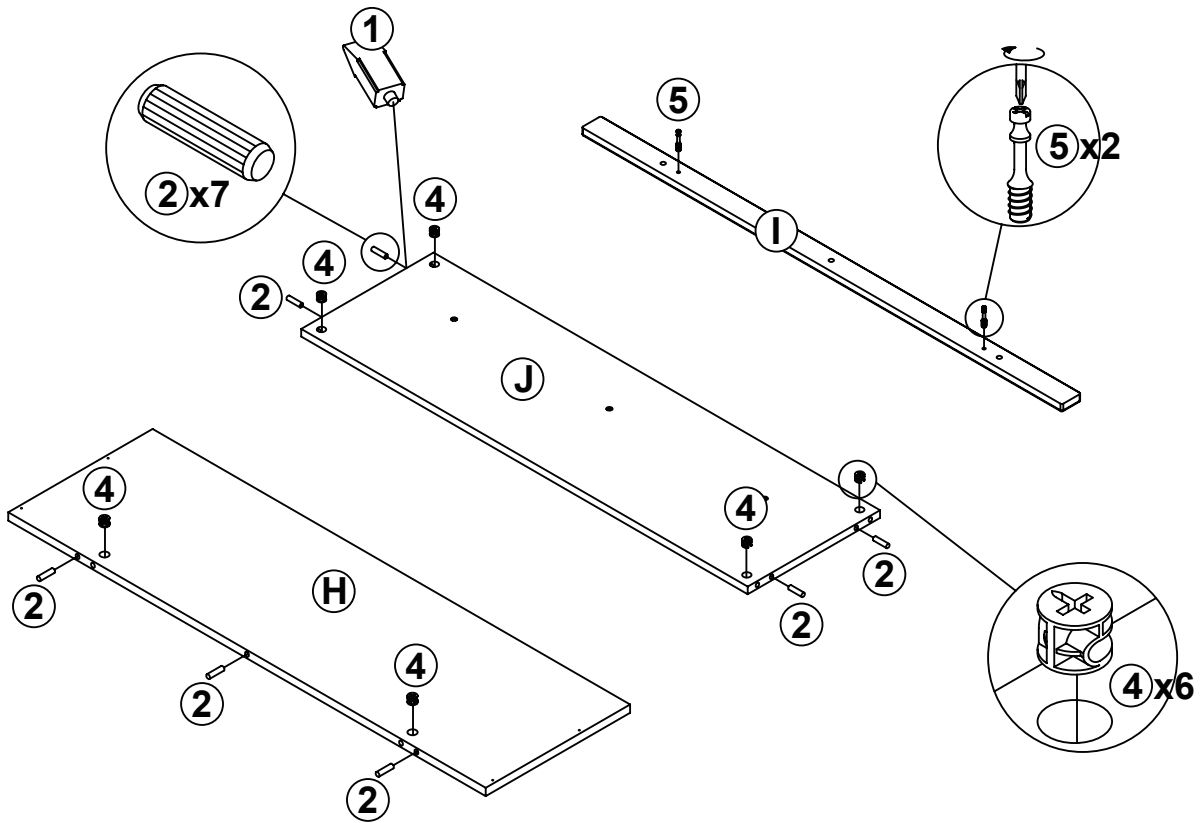

STEP 5

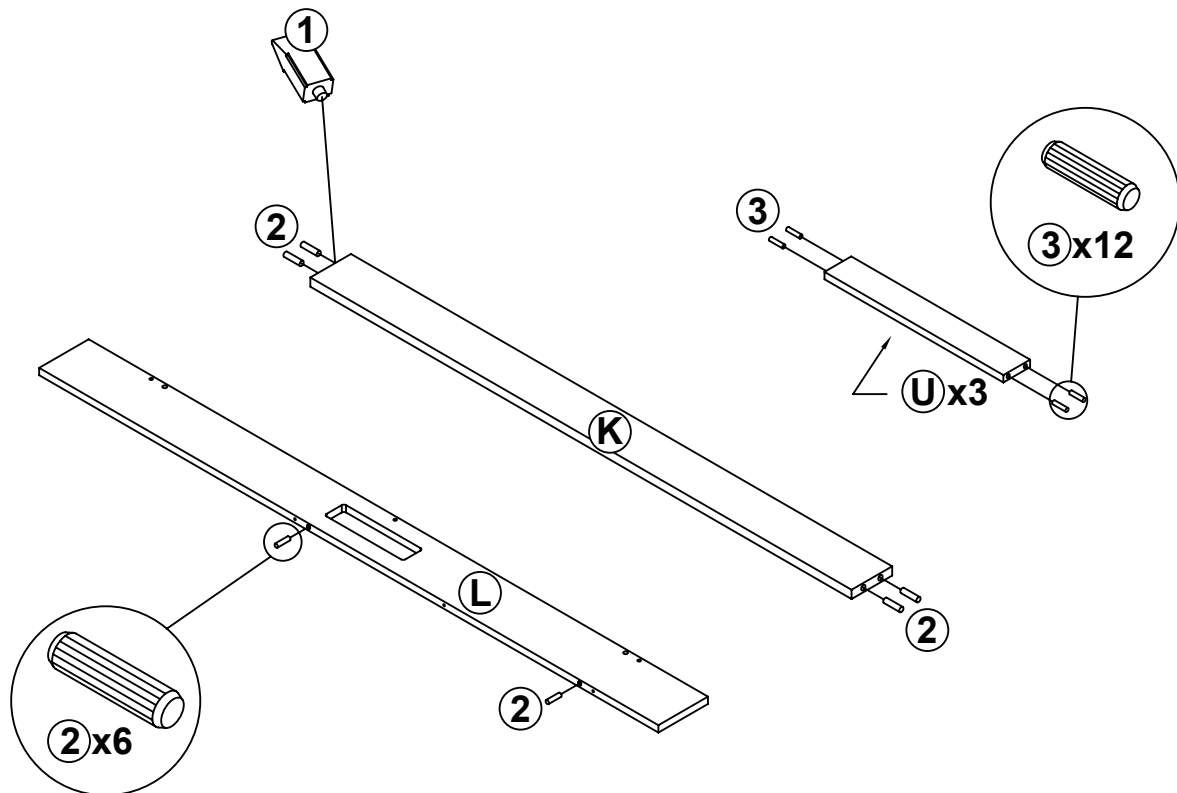

STEP 6

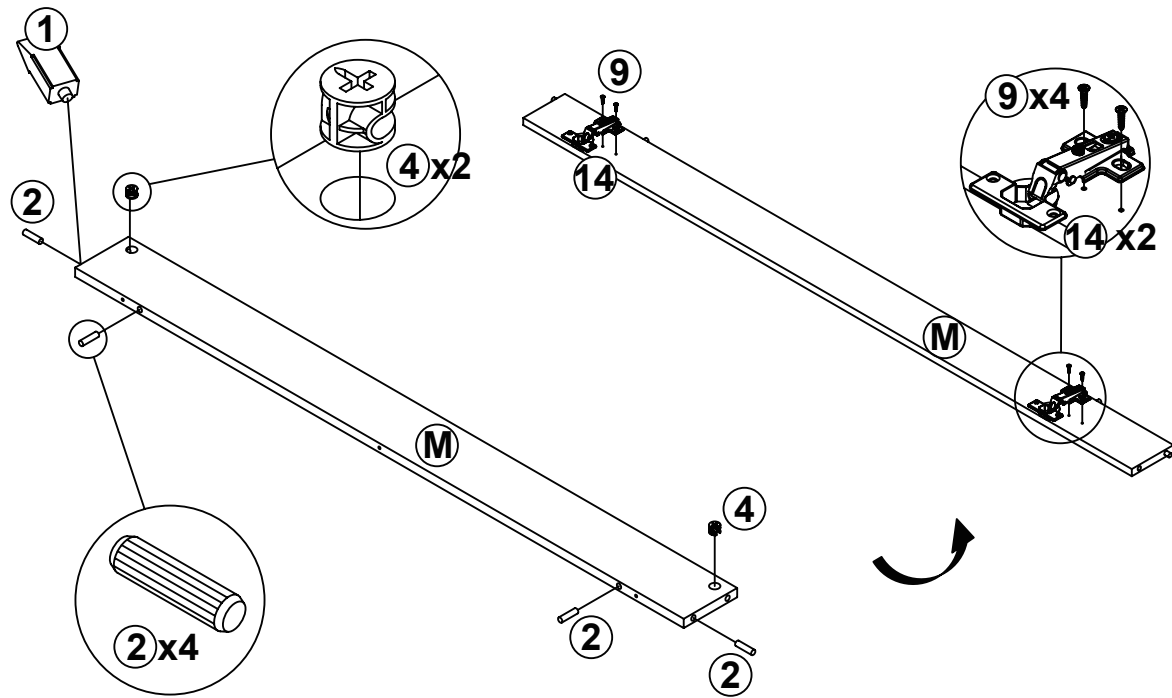

STEP 7

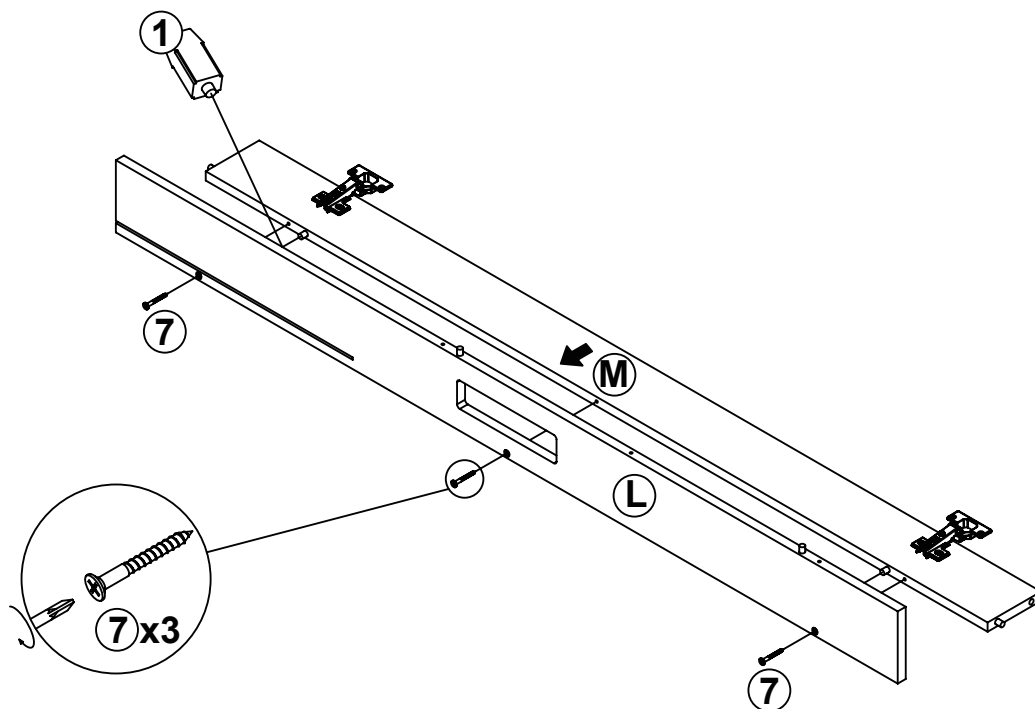

STEP 8

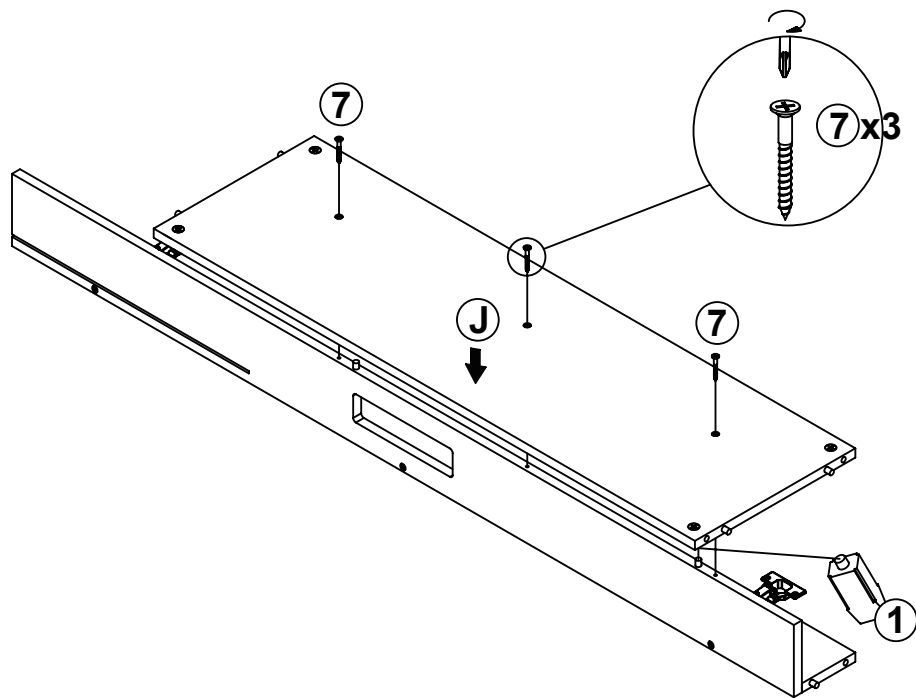

STEP 9

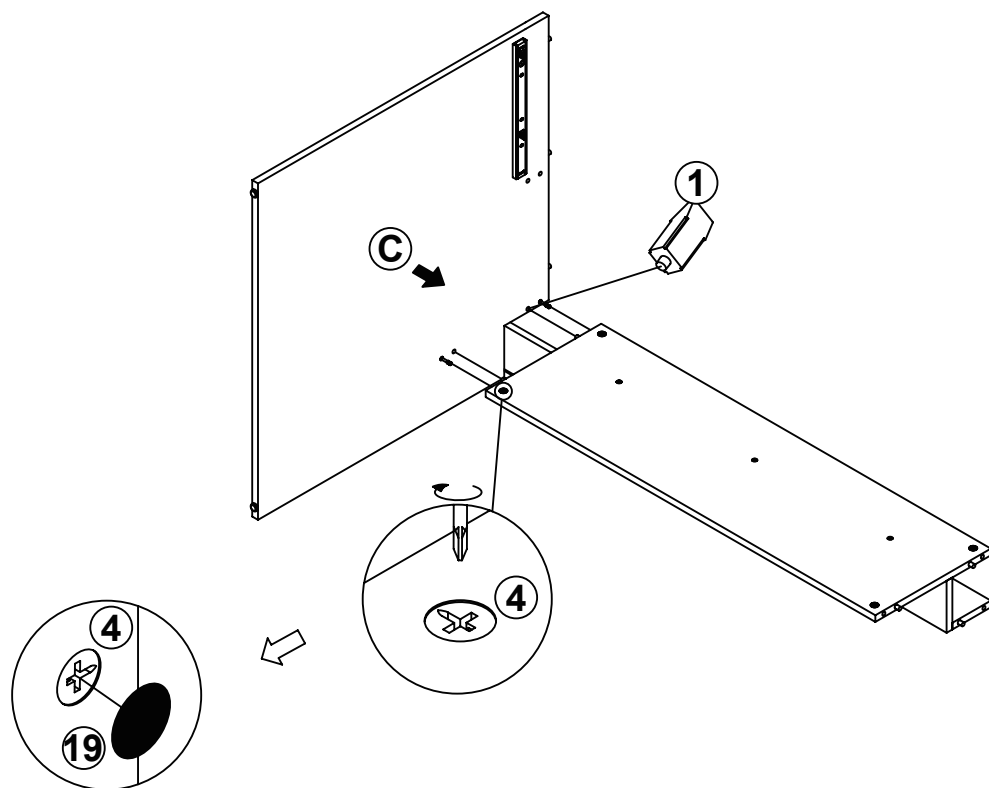

STEP 10

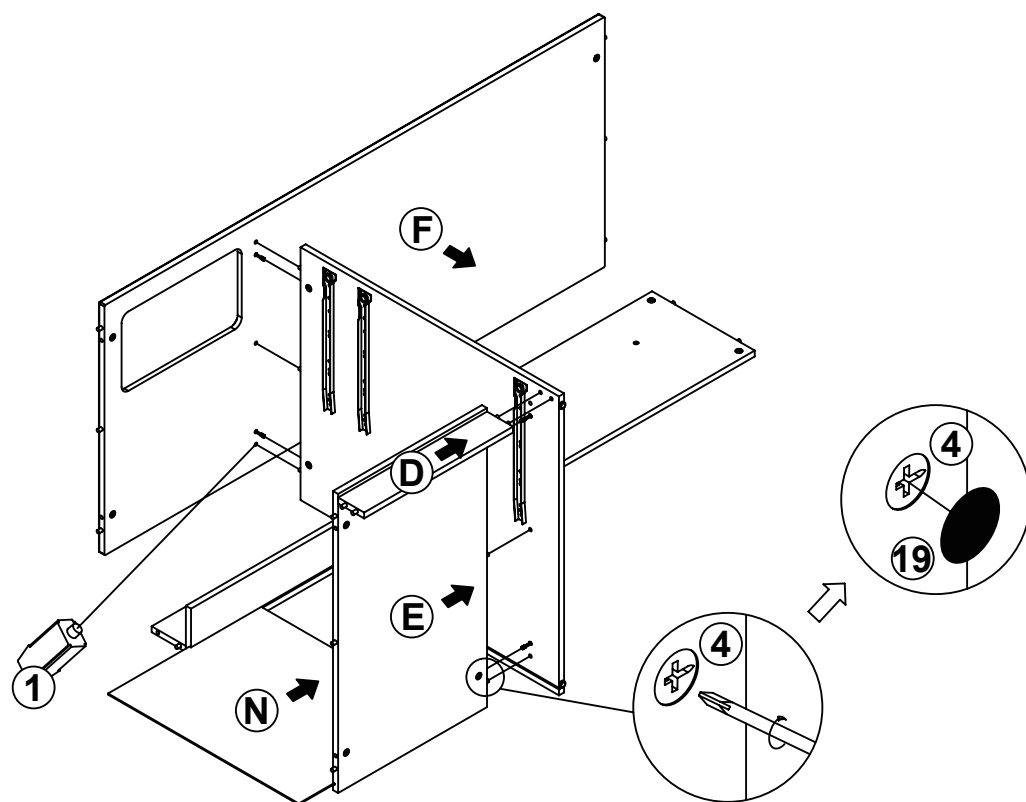

STEP 11

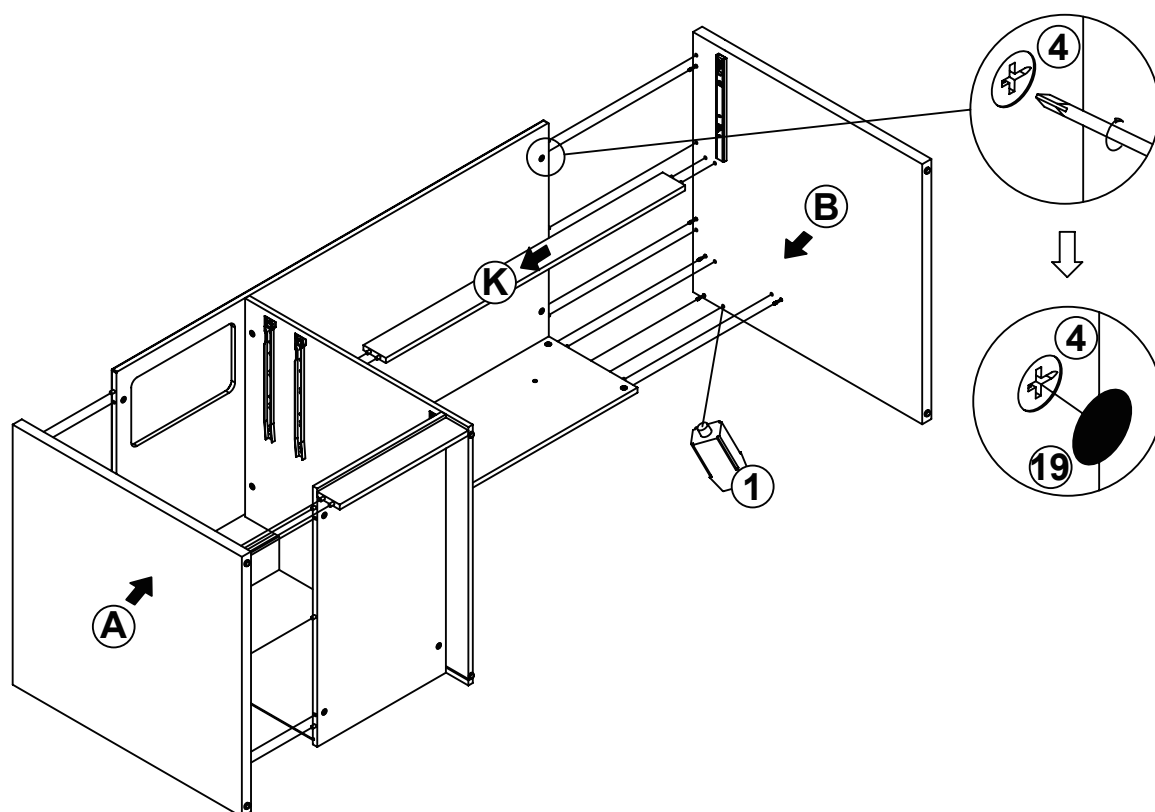

STEP 12

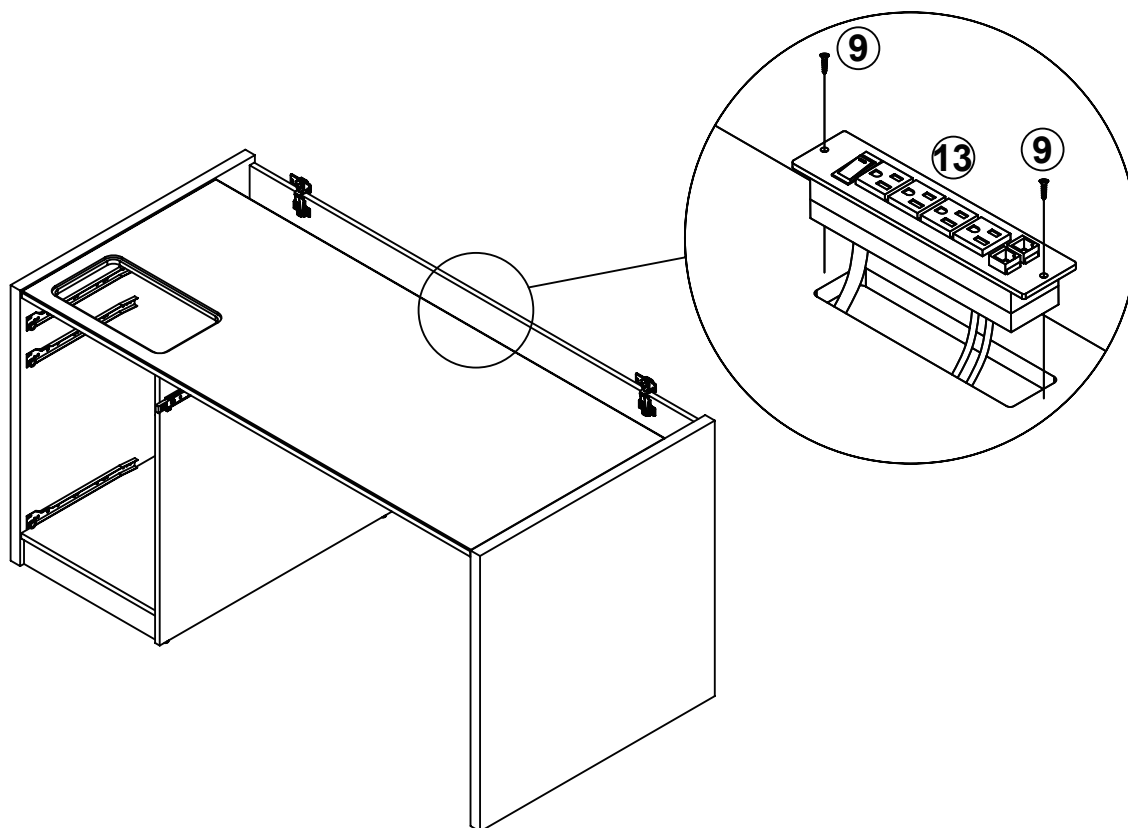

STEP 13

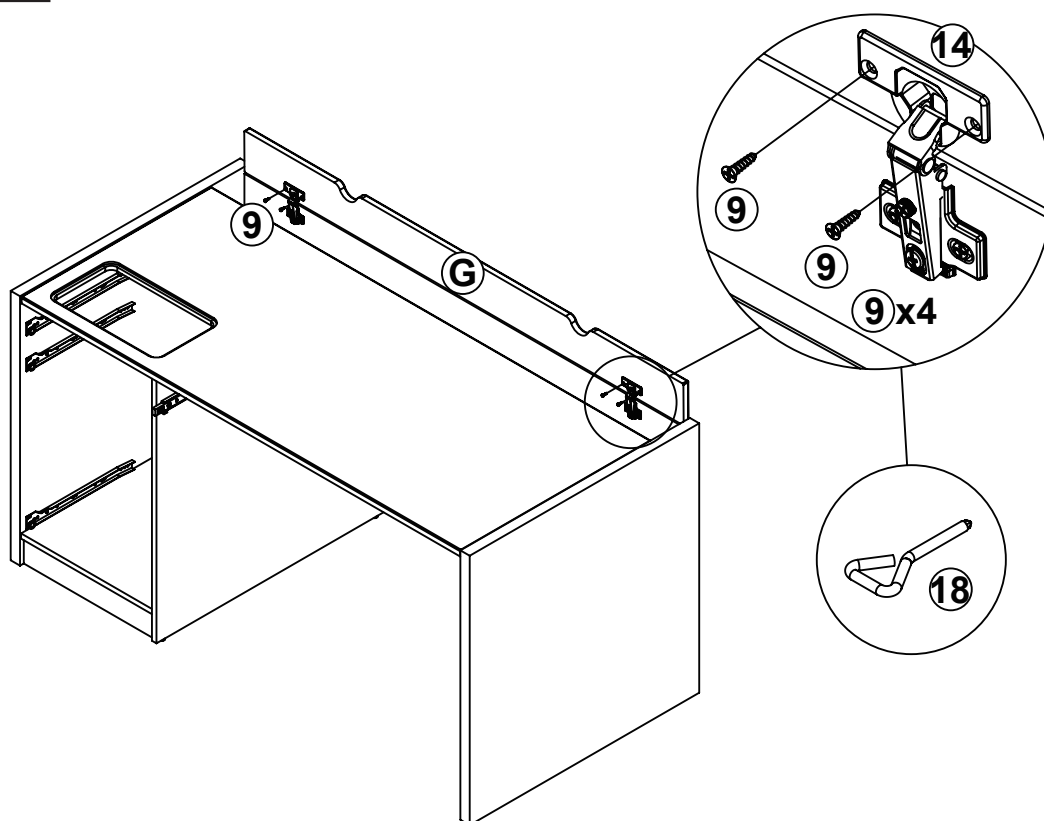

STEP 14

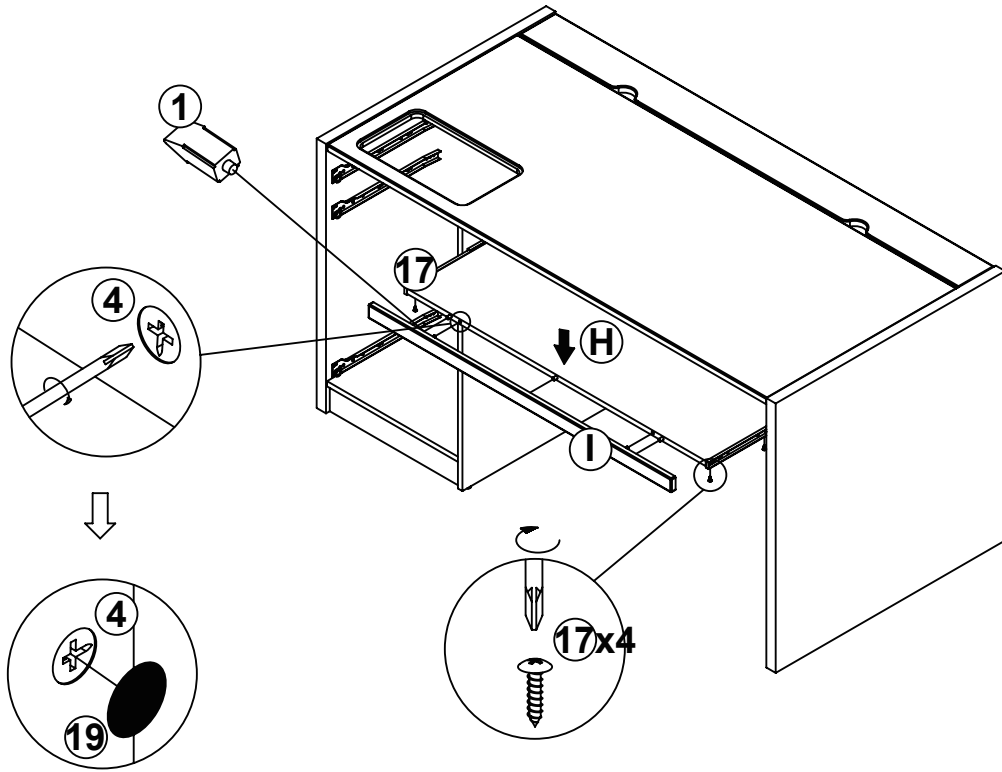

STEP 15

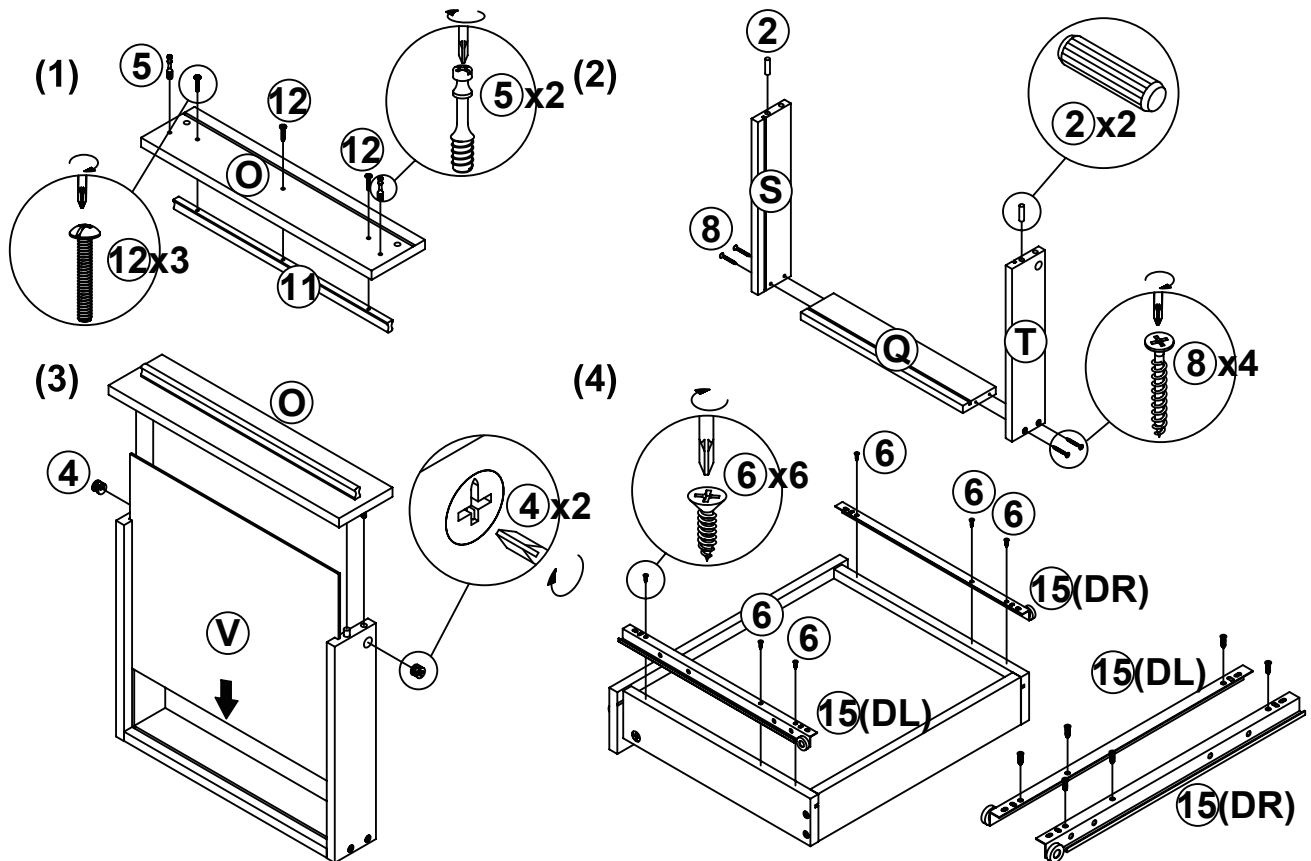

STEP 16

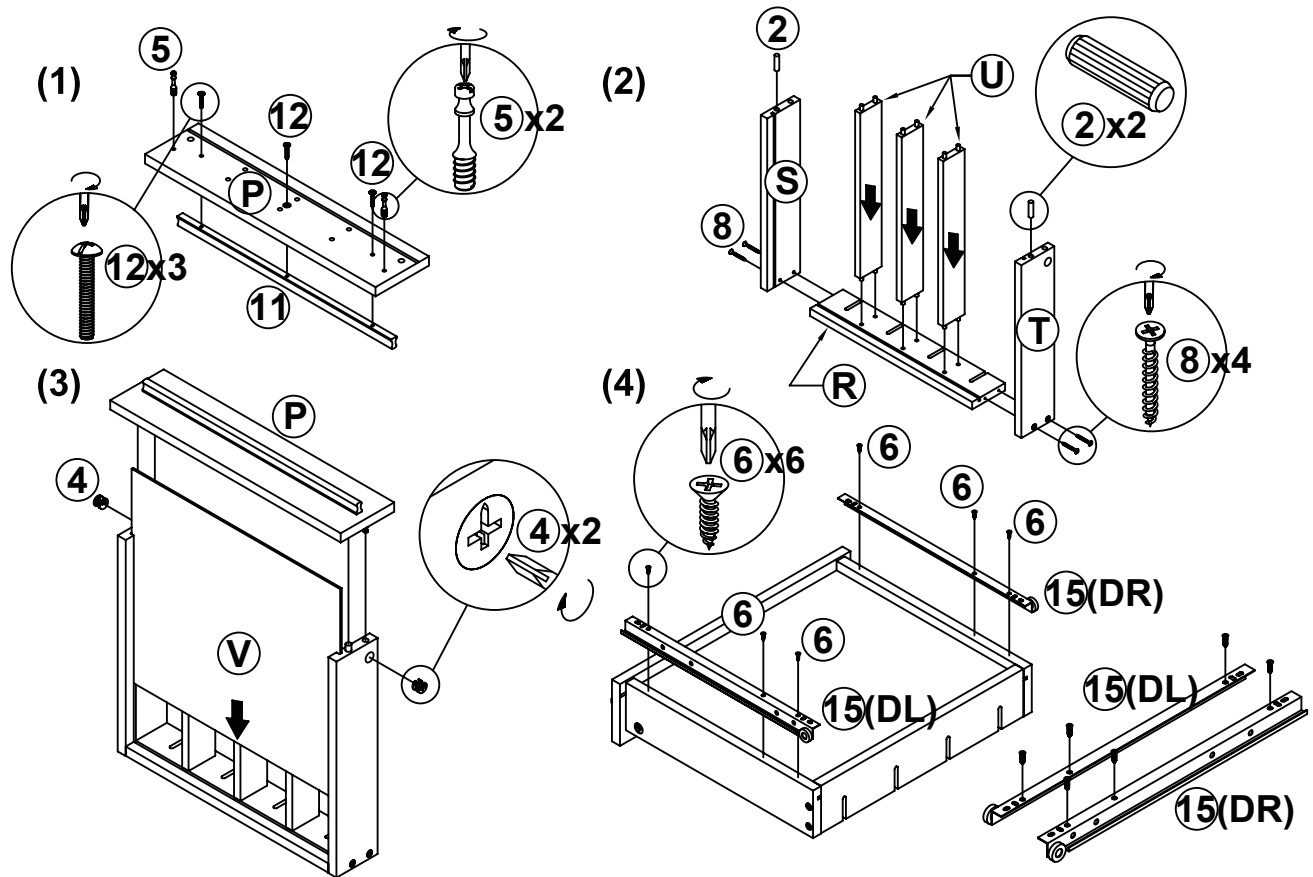

STEP 17

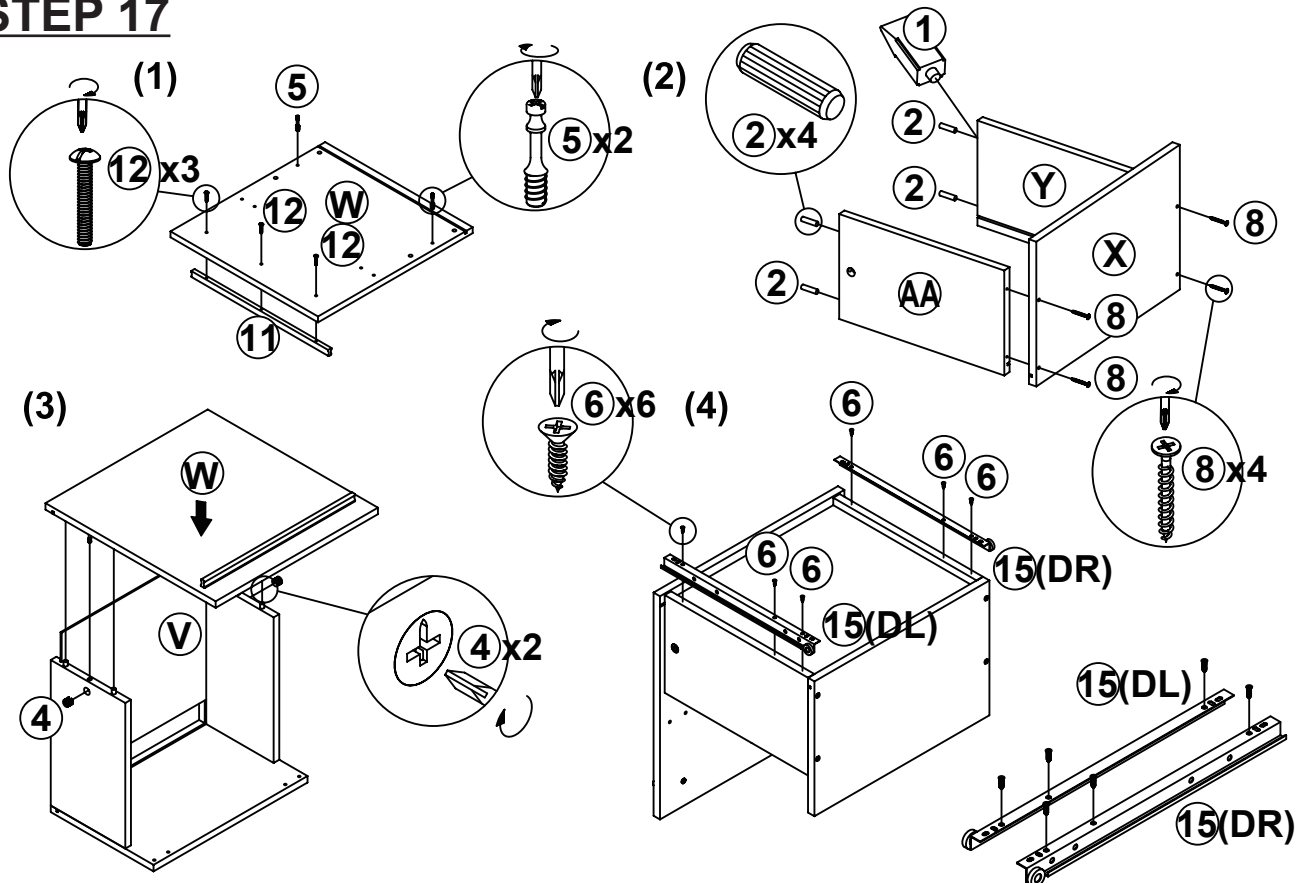

STEP 18

Insert rails in outside holes for large files.
Insert rails in inside holes for small files.

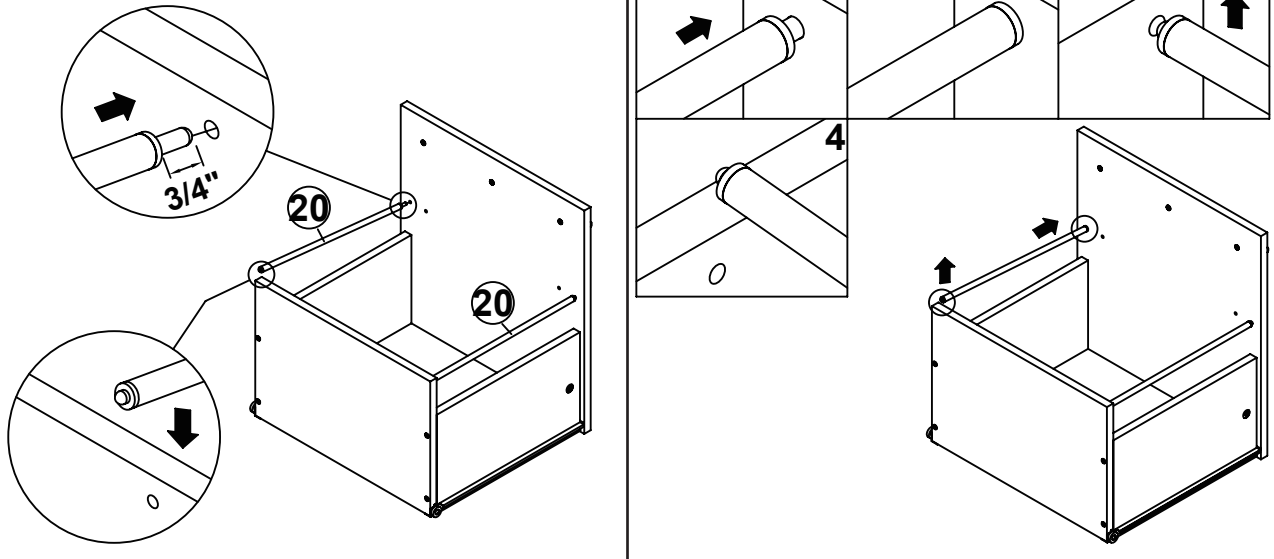

STEP 19

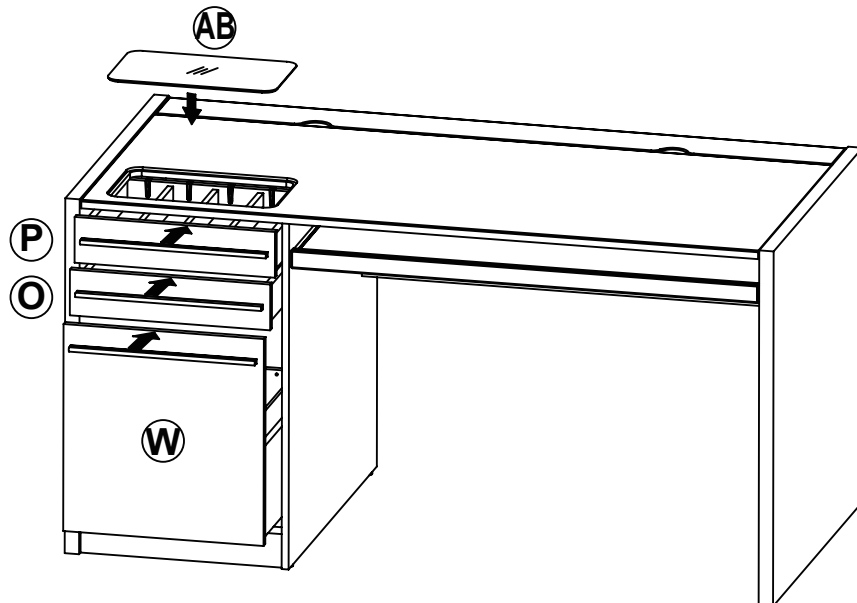

STEP 20

COMPLETE

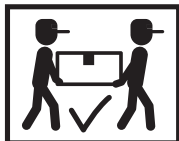
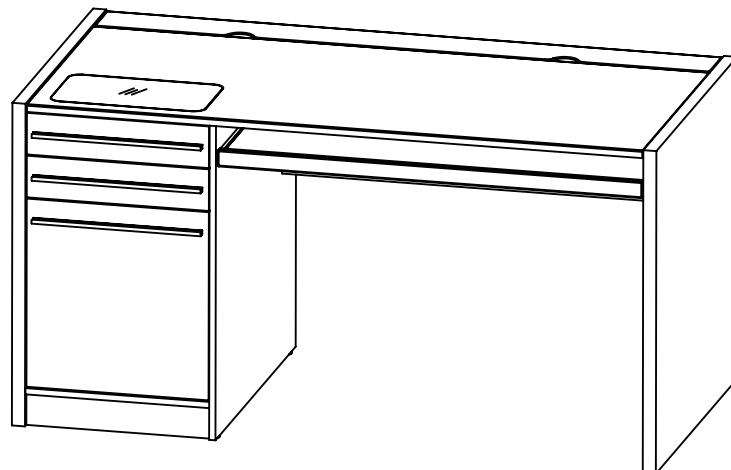

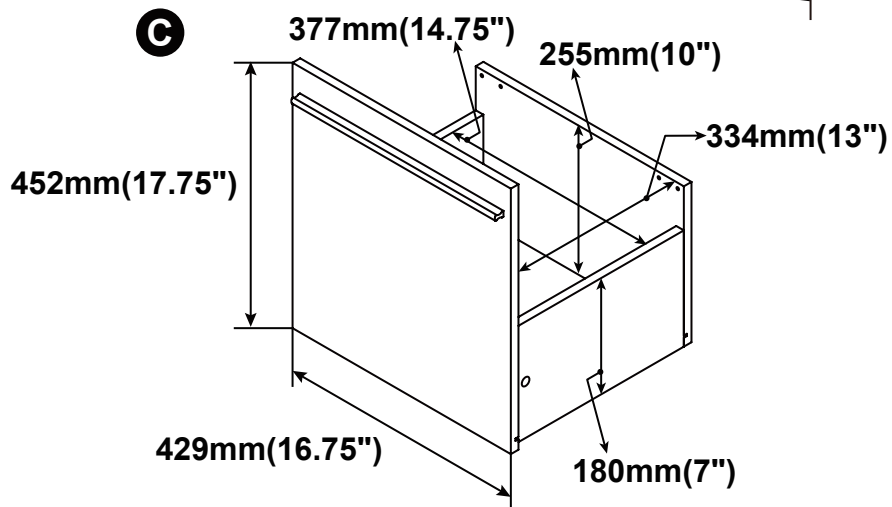
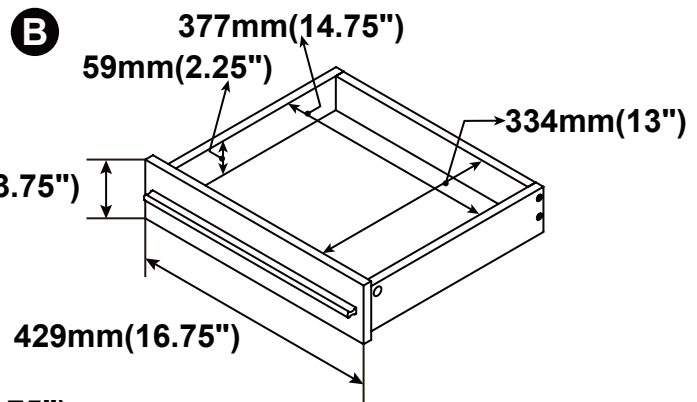
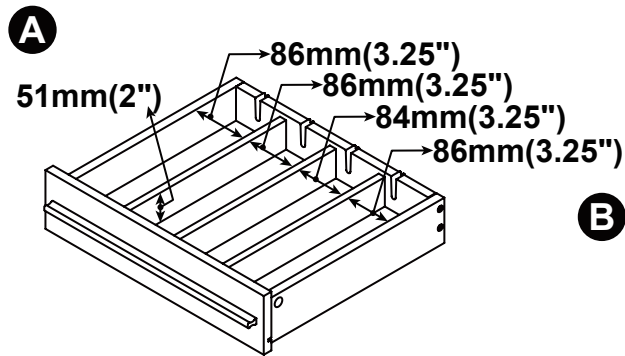
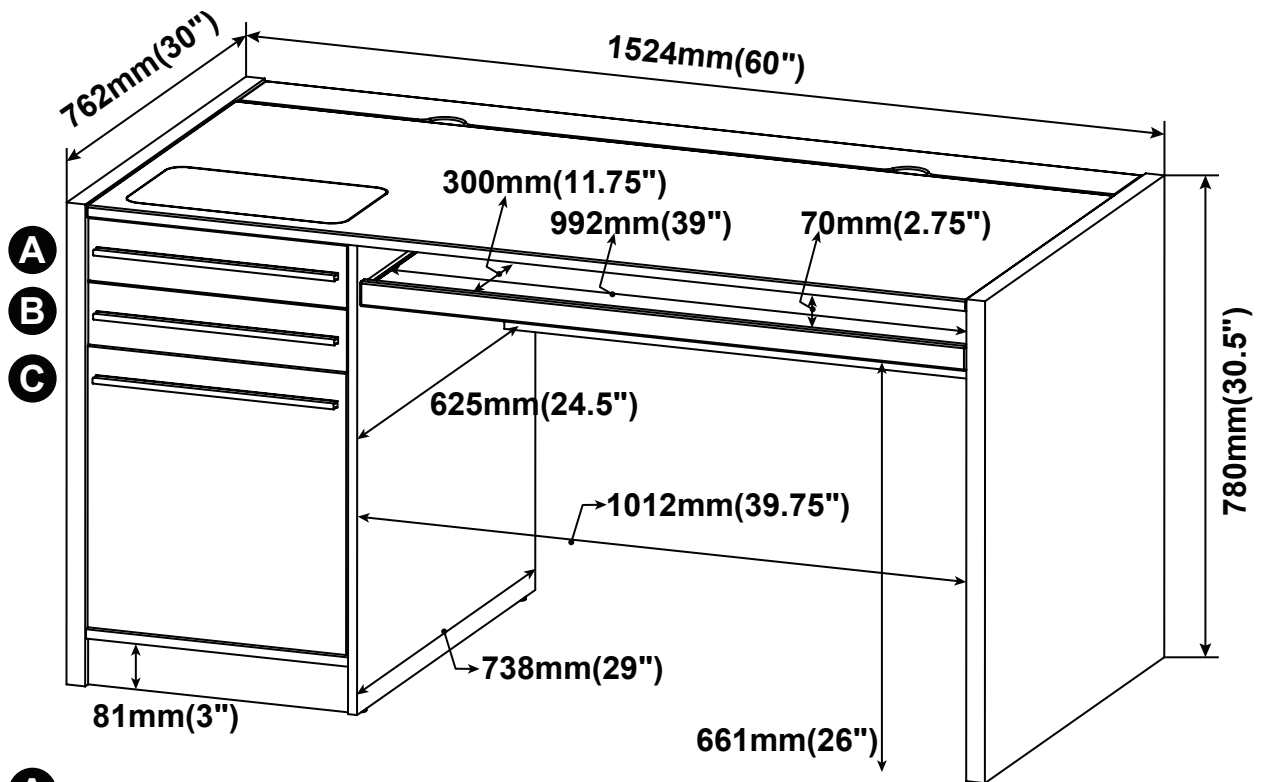

Note : Dimension tolerance $\pm 5\%$