

ASSEMBLY INSTRUCTIONS
COASTER FINE FURNITURE



Fine Furniture for every stage of life

706208(B1&B2)
Coffee Table

ITEM: 706208(B1&B2)



ASSEMBLY INSTRUCTIONS

ASSEMBLY TIPS:

1. Remove hardware from box and sort by size.
2. Please check to see that all hardware and parts are present prior to start of assembly.
3. Please follow attached instructions in the same sequence as numbered to assure fast & easy assembly.



WARNING!

1. Don't attempt to repair or modify parts that are broken or defective. Please contact the store immediately.
2. This product is for home use only and not intended for commercial establishments.



ASSEMBLY TIME

10 MINUTES

PARTS IDENTIFICATION

B1 (BOX 1)

A TOP



1PC

B2 (BOX 2)

B LEG FRAME WITH LABEL "B"



1PC

C LEG FRAME WITH LABEL "C"



1PC

HARDWARE IDENTIFICATION

Z-B2 (BOX 2) - HARDWARE PACK IS LOCATED IN 706208(B2)

1 LONG BOLT
(M6 x 16mm - BLK)



6PCS

2 SHORT BOLT
(M6 x 12mm - BLK)



2PCS

3 FLAT WASHER
(M8 x 16 mm - BLK)



6PCS

4 ALLEN WRENCH
(4mm - BLK)

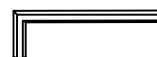

1PC

ITEM: 706208(B1&B2)

ASSEMBLY INSTRUCTIONS

STEP 1

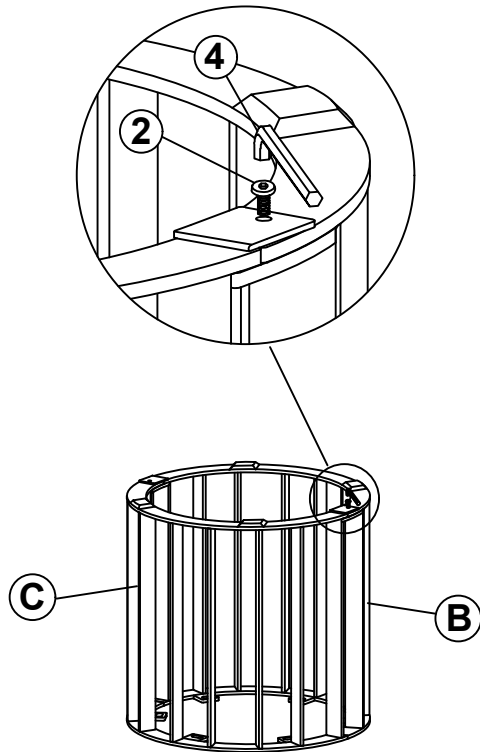

STEP 3

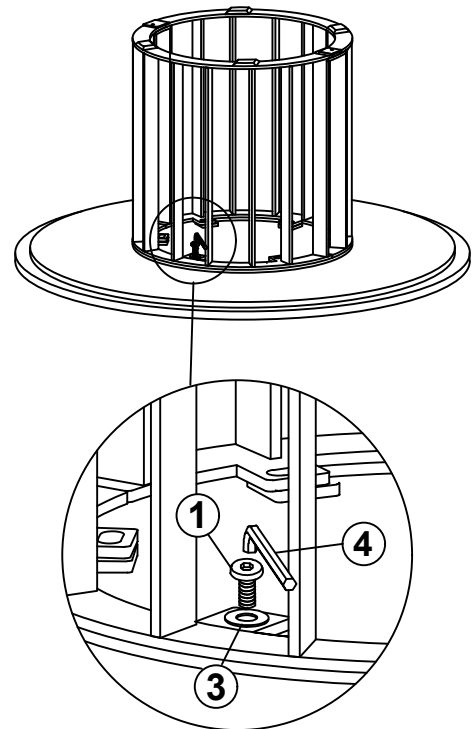

STEP 2

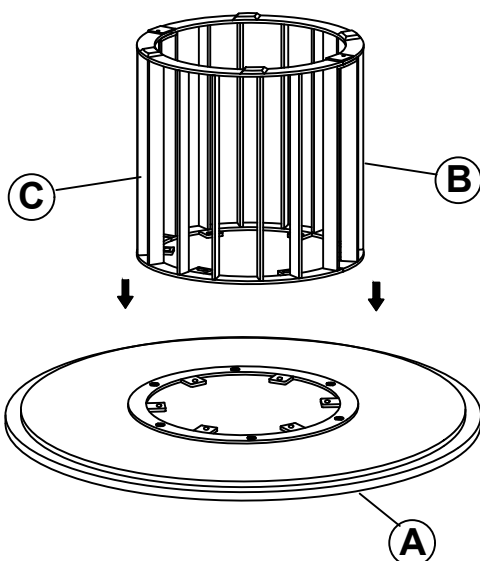

STEP 4

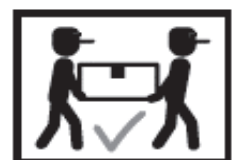
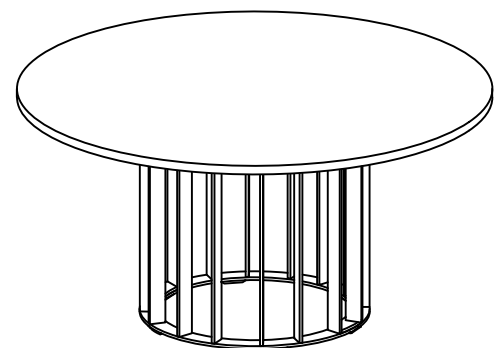

ITEM: 706208(B1&B2)

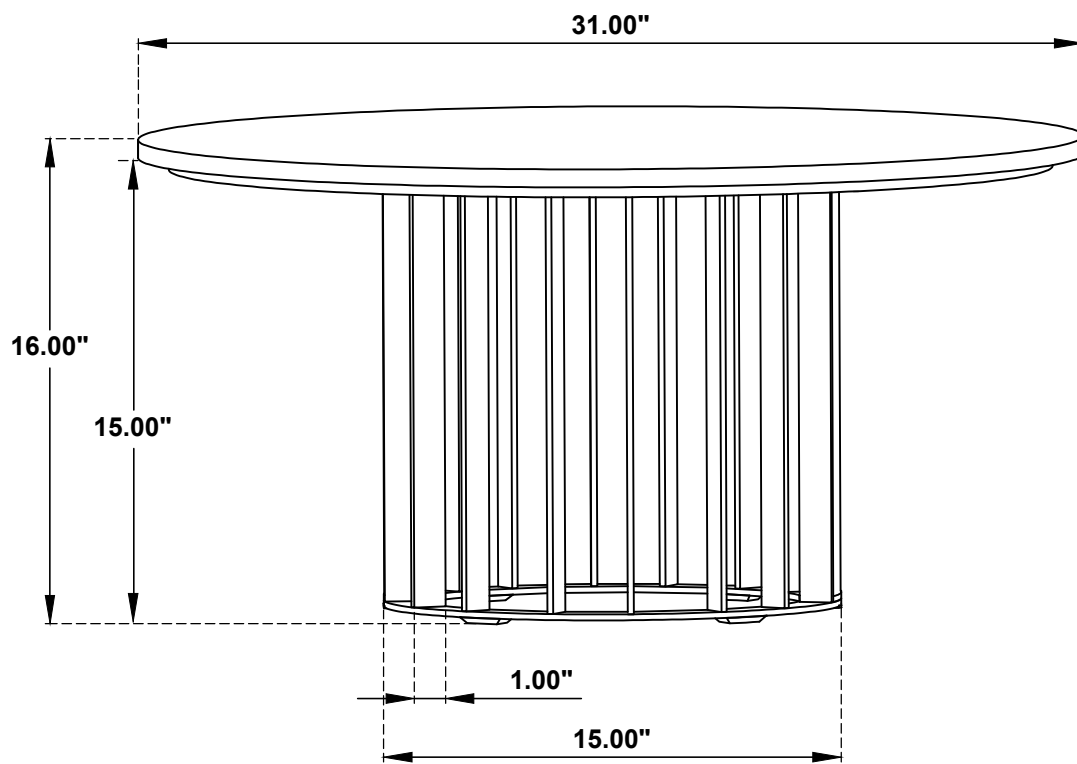

Note : Dimension tolerance $\pm 5\%$