

# Assembly Guide

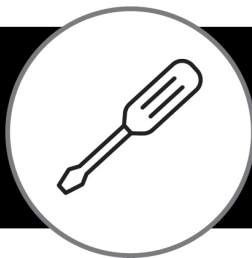

**If you're having any difficulty during assembly of this product, don't hesitate to call us**

Our customer service experts are trained to provide step-by-step instruction and can easily replace any missing or damaged parts.

60W Hutch

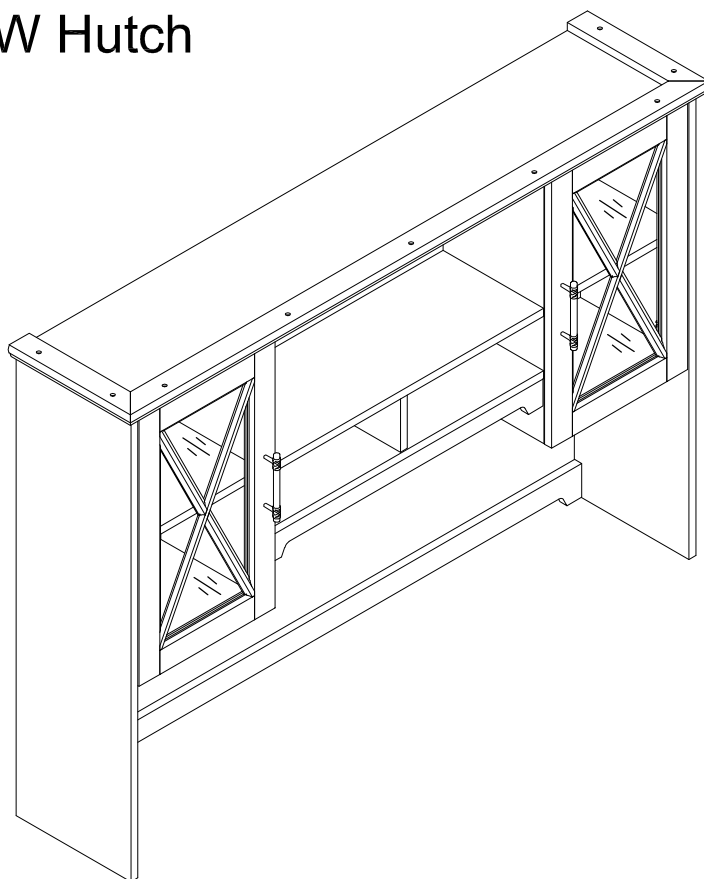

# IT'S AS EASY AS 1,2,3

**Assembly tips:**

1. Read the instructions and become familiar with the parts.
2. Ensure this carton contains all parts, fasteners and hardware.
3. To protect floors, assemble the furniture on the carton.
4. An assistant may be helpful.
5. Use of power tools is not recommended.

**Conseils d'assemblage:**

1. Lisez les instructions et familiarisez-vous avec les pièces.
2. Assurez-vous que le carton contient toutes les pièces, toutes les pièces de fixation et toute la quincaillerie.
3. Pour protéger vos sols, assemblez le meuble sur le carton.
4. Il peut être utile de vous faire aider.
5. L'utilisation d'outils électriques n'est pas recommandée.

**Consejos de Ensamblaje:**

1. Lea las instrucciones y familiarícese con las partes.
2. Asegúrese de que esta caja contenga todas las piezas, los sujetadores y el equipo.
3. Para proteger el piso, ensamble el mueble en el carton.
4. Un asistente puede serle útil.
5. El uso de herramientas eléctricas no se recomienda.

## Get Ready to Assemble

### For best results, keep these tips in mind:

- ① We know you want to finish this assembly as quickly as possible, but trust us: you'll have a better experience if you take it one step at a time.
- ② Give yourself some room to work near where you want the fully assembled product.
- ③ If your floor isn't carpeted, assemble this product on the empty carton to avoid scratching.
- ④ Do you have a friend who owes you a favor? Some steps may go a little easier with a second set of hands.

### DOs

- ✔ Use a #2 Phillips head screwdriver (or other handheld tools as indicated)
- ✔ Wear safety glasses at all times during assembly
- ✔ Carefully follow the instructions in this guide and complete all steps in order
- ✔ Give us a call if you're having trouble with a particularly tricky step

### DON'Ts

- ✘ We know power tools are quick and easy, but you shouldn't use them when assembling this product (unless otherwise specified)
- ✘ Never move your furniture with items inside or resting on the surface
- ✘ Do not attempt to use this product before all steps have been completed

# IMPORTANT SAFETY INFORMATION



## PLEASE READ WARNINGS

Improper use can cause safety hazards, or damage to your furniture and household items.

Warning	Do	Don't	Why it's important
<b>Serious injury may occur.</b>	<ul style="list-style-type: none"><li>Assemble following all instructions using all indicated parts and hardware provided.</li><li>Attach hutch only as described in the instructions.</li><li>Verify furniture is stable on it's own.</li><li>Only place against a permanent wall structure at least as tall as the hutch or place back-to-back with hutch of same size.</li></ul>	<ul style="list-style-type: none"><li>Do not move unit when loaded.</li><li>Do not load with a television or other heavy equipment.</li><li>Do not exceed the maximum load limits stated in the instructions.</li><li>Do not allow children to climb, or hang on furniture.</li></ul>	Improper assembly, use or loading can lead to product instability, tipover, or collapse.

Advertencia	Hacer	No	Por qué es importante
<b>Pueden producirse lesiones graves.</b>	<ul style="list-style-type: none"><li>Realice el montaje siguiendo todas las instrucciones y utilizando todas las piezas indicadas y los herrajes suministrados.</li><li>Fije la conejera como se describe en las instrucciones.</li><li>Compruebe que el mueble sea estable por sí mismo.</li><li>Colóque el producto únicamente contra una estructura de pared permanente y fíjelo directamente a los montantes de la pared siguiendo las instrucciones.</li></ul>	<ul style="list-style-type: none"><li>No mueva la unidad cuando esté cargada.</li><li>No cargue el mueble con un televisor u otro equipo pesado.</li><li>No supere los límites máximos de carga indicados en las instrucciones.</li><li>No permita que los niños trepen o se cuelguen de los muebles.</li></ul>	El montaje, uso o carga inadecuados pueden provocar inestabilidad, vuelco o colapso del producto.

## IMPORTANT SAFETY INFORMATION



# PLEASE READ WARNINGS

Improper use can cause safety hazards, or damage to your furniture and household items.

Avertissement	À faire	À ne pas faire	Pourquoi c'est important
<b>Peut entraîner des blessures graves.</b>	<ul style="list-style-type: none"><li>• Assembler en suivant toutes les instructions et en utilisant toutes les pièces et la quincaillerie incluses.</li><li>• Fixez la huche conformément aux instructions.</li><li>• Assurez-vous que le meuble soit stable par lui-même.</li><li>• Placer uniquement contre une structure murale permanente et fixer directement aux montants du mur selon les instructions.</li></ul>	<ul style="list-style-type: none"><li>• Ne pas déplacer le meuble lorsqu'il est chargé.</li><li>• Ne pas charger le meuble avec un téléviseur ou tout autre équipement lourd.</li><li>• Ne pas dépasser les limites de poids maximales indiquées dans les instructions.</li><li>• Ne pas laisser les enfants grimper ou s'accrocher aux meubles.</li></ul>	Un assemblage, une utilisation ou un chargement incorrects peuvent entraîner l'instabilité, le basculement ou l'effondrement du produit.

# IMPORTANT SAFETY INFORMATION



## PLEASE READ WARNINGS

Improper use can cause safety hazards, or damage to your furniture and household items.

Caution	Do	Don't	Why it's important
<b>Serious injury may occur.</b>	<ul style="list-style-type: none"><li>• Handle glass carefully during assembly.</li><li>• Use proper eye and hand protection.</li></ul>	<ul style="list-style-type: none"><li>• Do not exceed maximum load limits stated in the instructions.</li></ul>	<ul style="list-style-type: none"><li>• Improper handling or loading may result in glass breakage.</li></ul>

Atención	Hacer	No	Por qué es importante
<b>Pueden producirse lesiones graves.</b>	<ul style="list-style-type: none"><li>• Manipule el vidrio con cuidado durante el montaje.</li><li>• Utilice protección adecuada para los ojos y las manos.</li></ul>	<ul style="list-style-type: none"><li>• No supere los límites máximos de carga indicados en las instrucciones.</li></ul>	<ul style="list-style-type: none"><li>• Una manipulación o carga inadecuada puede provocar la rotura del vidrio.</li></ul>

Attention	À faire	À ne pas faire	Pourquoi c'est important
<b>Peut entraîner des blessures graves.</b>	<ul style="list-style-type: none"><li>• Manipuler le verre avec précaution pendant l'assemblage.</li><li>• Utiliser une bonne protection pour les yeux et les mains.</li></ul>	<ul style="list-style-type: none"><li>• Ne pas dépasser les limites de poids maximales indiquées dans les instructions.</li></ul>	<ul style="list-style-type: none"><li>• Une manipulation ou un chargement inadéquats risquent de briser le verre.</li></ul>

# Get to know your Boards

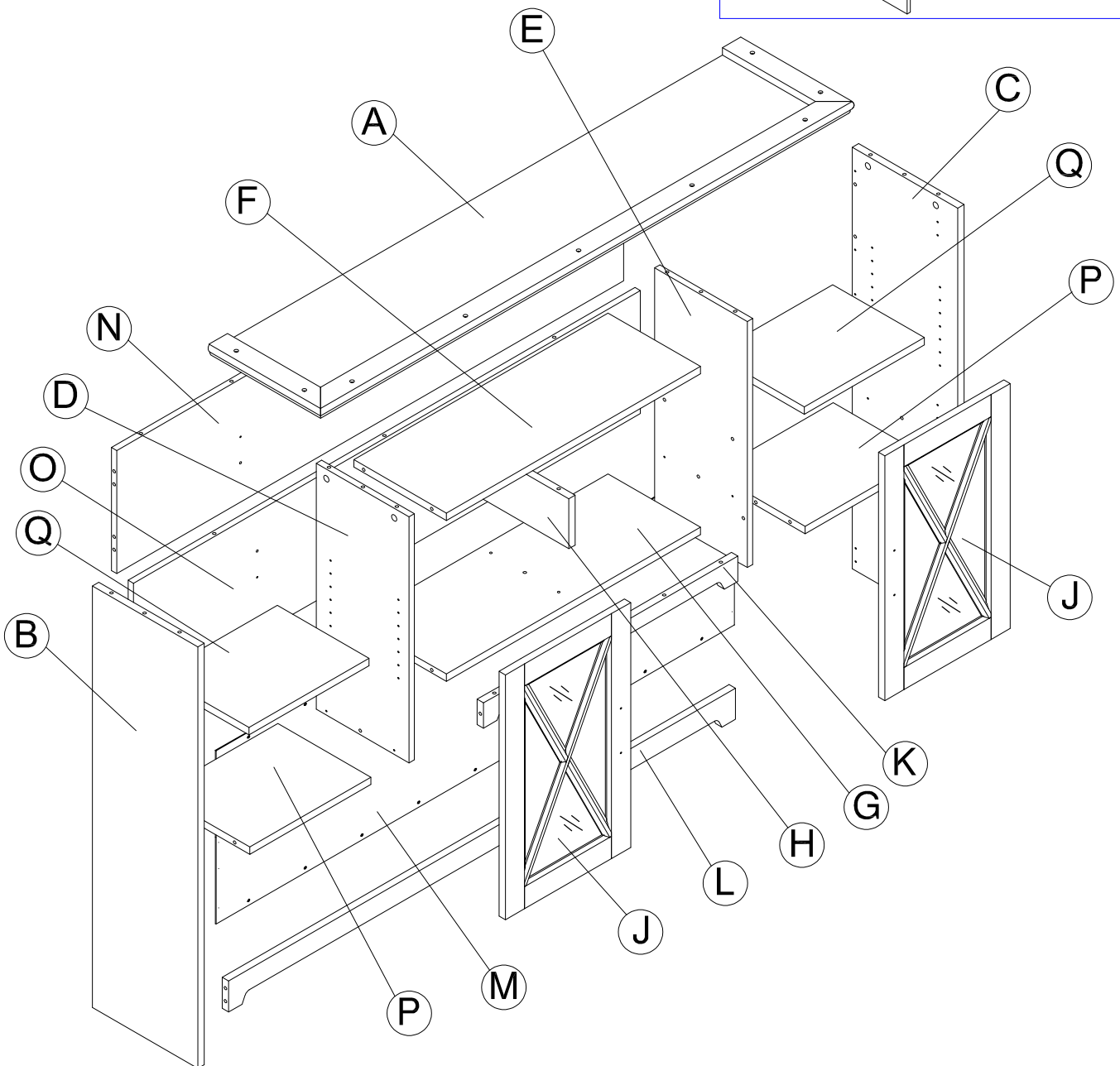
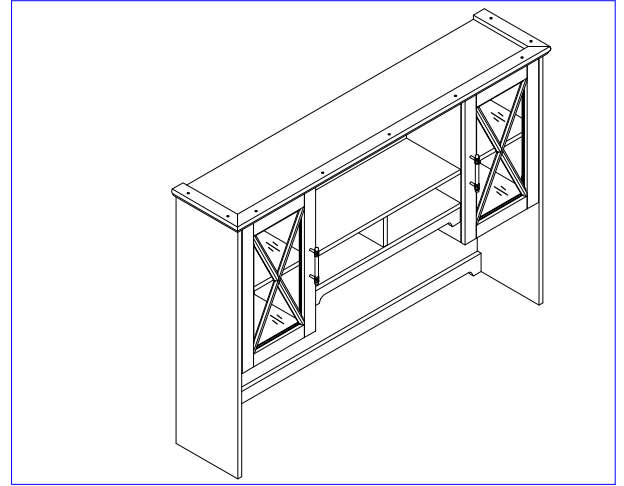

# Get to know your Fasteners

Fasteners are shown actual size.

H38169



Wood Dowel  
8 x 30mm

[ 37 ]

H181468

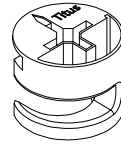

KD Cam

[ 41 ]

H72988

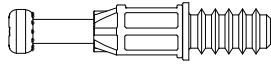

KD Bolt

[ 41 ]

H208081

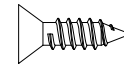

#8 x 5/8"

[ 8 ]

H160460

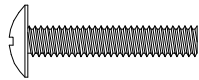

M4 x 22mm

[ 4 ]

H34174



#3 x 3/4"

[ 12 ]

H23198

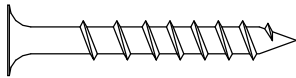

#10 x 1-1/2"

[ 8 ]

H211930

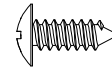

#8 -18x 15/32"

[ 18 ]

H23682

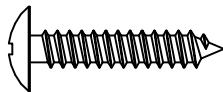

#10 x 1"

[ 8 ]

# Get to know your Hardware

Hardware not to scale.

H170611

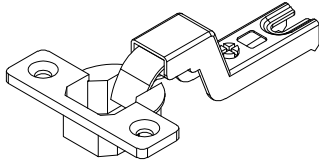

[ 4 ]

Hinge Arm

H170612

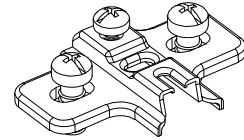

[ 4 ]

Mounting Plate

H209491

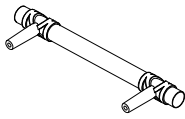

[ 2 ]

Handle

H200203



[ 22 ]

Cover Cap

H158707

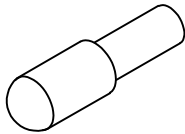

[ 8 ]

Shelf Pin

H209492

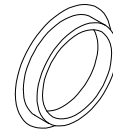

[ 2 ]

Hole Plug

H211039

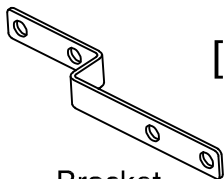

[ 2 ]

Bracket

H149989



[ 4 ]

Bumper

# Get to know your Hardware

Hardware not to scale.

## TIP OVER RESTRAINT HARDWARE

### Q203419

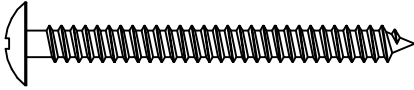
H181434  [ 1 ]  
#10x2"

H107572  [ 1 ]  
#8x1-1/2"

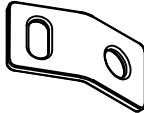
H181412  [ 2 ]  
Connecting Plate

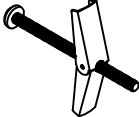
H181419  [ 1 ]  
Toggle Bolt

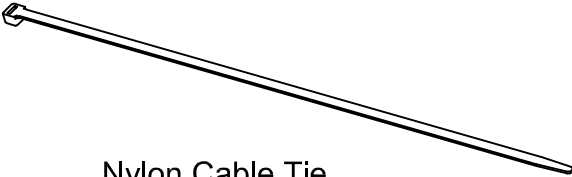
H181411  [ 1 ]  
Nylon Cable Tie

Have an assembly question or need a replacement part? Just call  
**1-800-950-4782**, we are here to help.

# STEP 1

# Prepare Doors

H170611

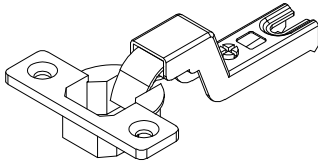

[ 4 ]

Hinge

H208081

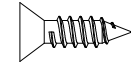

[ 8 ]

#8 x 5/8"

H209491

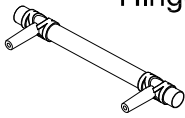

[ 2 ]

Handle

H160460

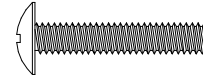

[ 4 ]

M4 x 22mm

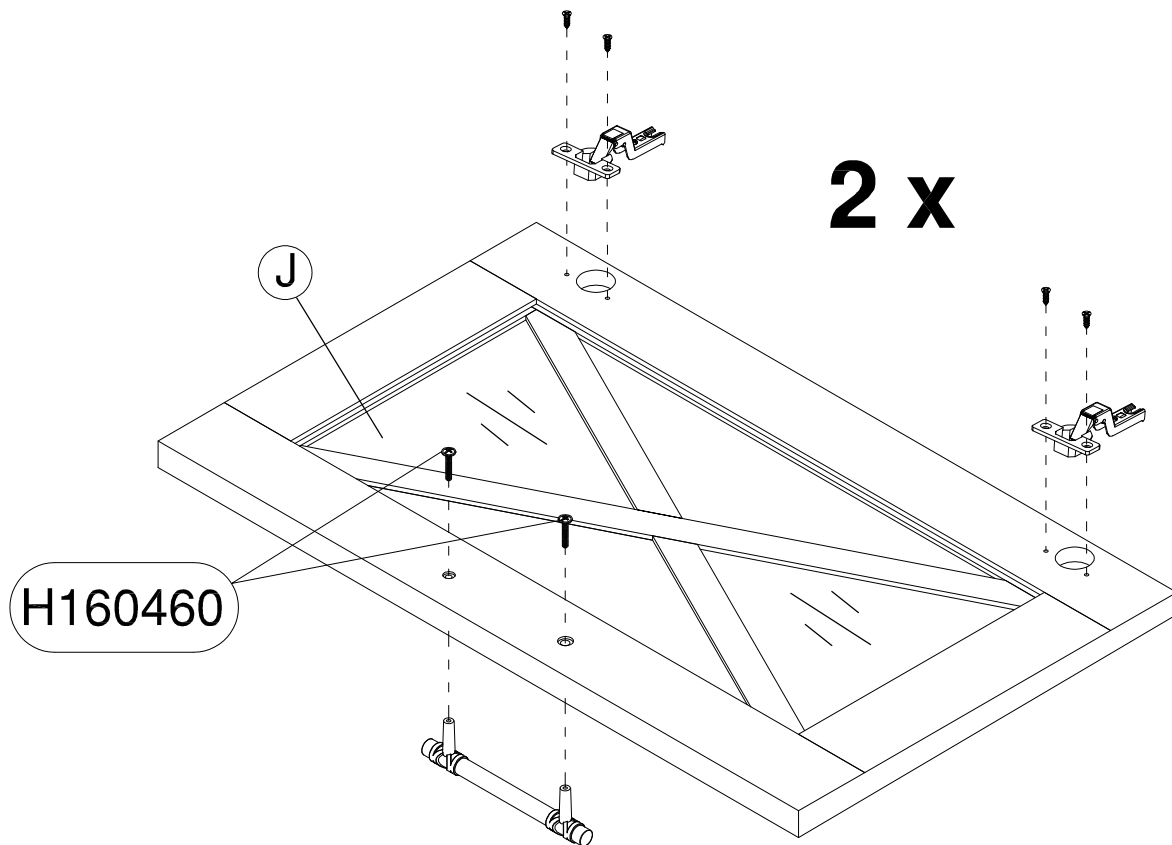

## CAUTION



Risk of breaking glass. Handle glass carefully during assembly. Use eye and hand protection. Improper handling can result in cuts or lacerations.

Riesgo de romper el vidrio. Maneje el vidrio con cuidado al ensamblar esta unidad. Use protección para sus ojos y sus manos. El manejo inapropiado del vidrio puede causarle cortaduras o laceraciones.

Risque de bris de verre. Faites attention lors de la manipulation du verre pendant l'assemblage. Utilisez des protections pour les yeux et les mains. Une mauvaise manipulation peut provoquer des coupures ou des lacérations.

# STEP 2

# Prepare Panels

H38169

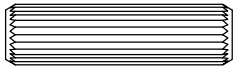

[ 6 ]

Wood Dowel  
8 x 30mm

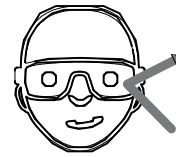
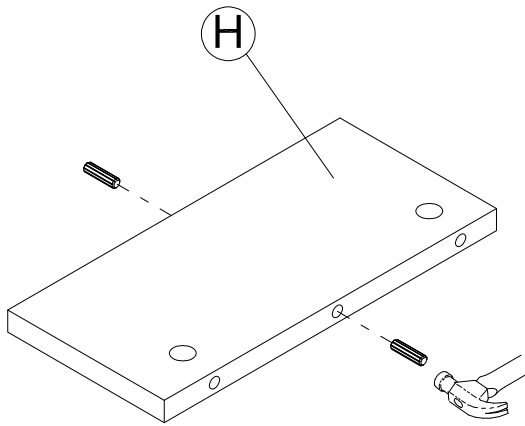

Safety glasses  
Gafas de seguridad  
Lunettes de protection

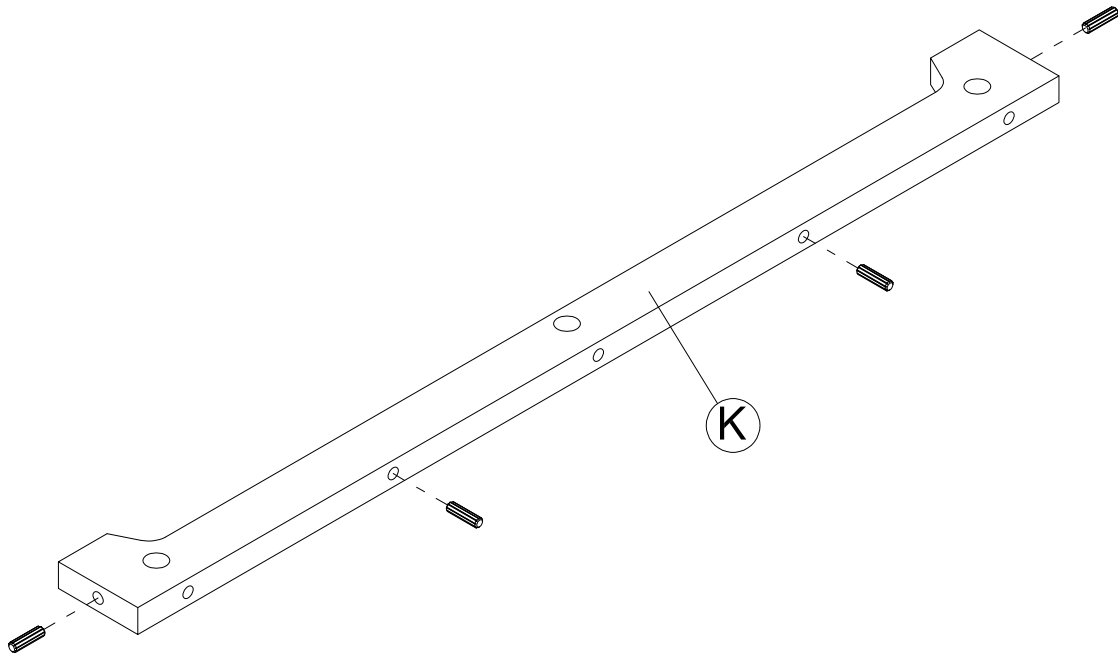

# STEP 3

# Prepare Panels

H38169

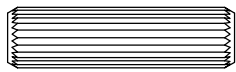

[ 6 ]

Wood Dowel  
8 x 30mm

H72988

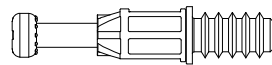

[ 5 ]

KD Bolt

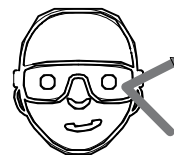
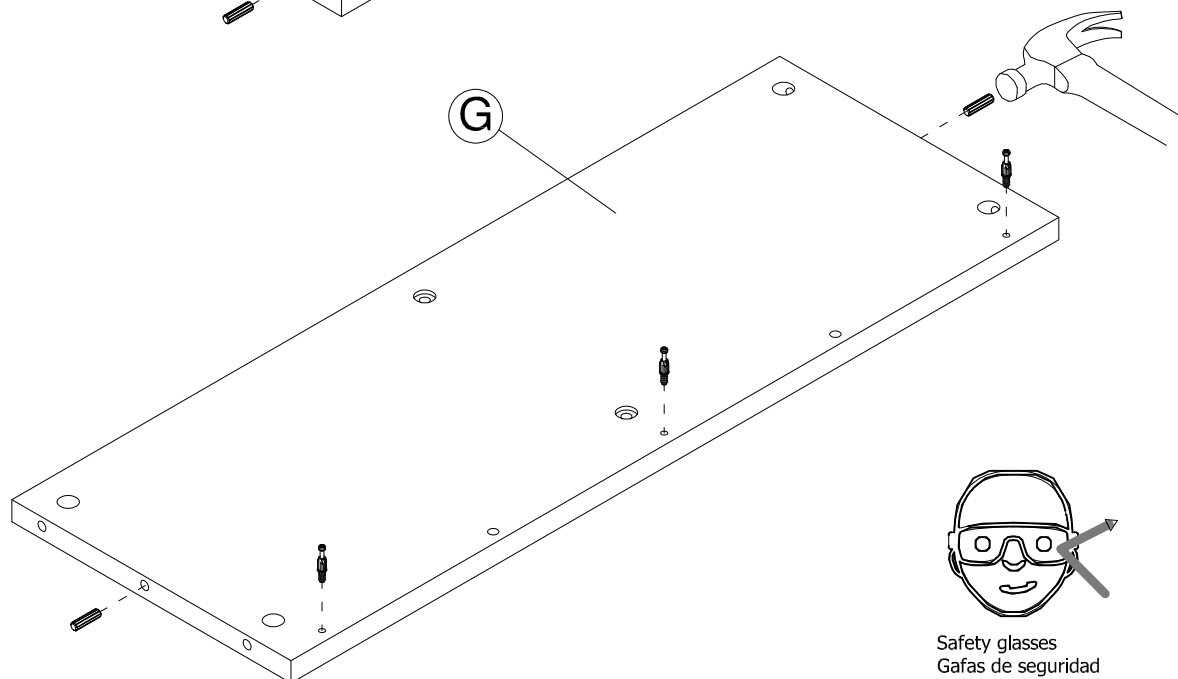
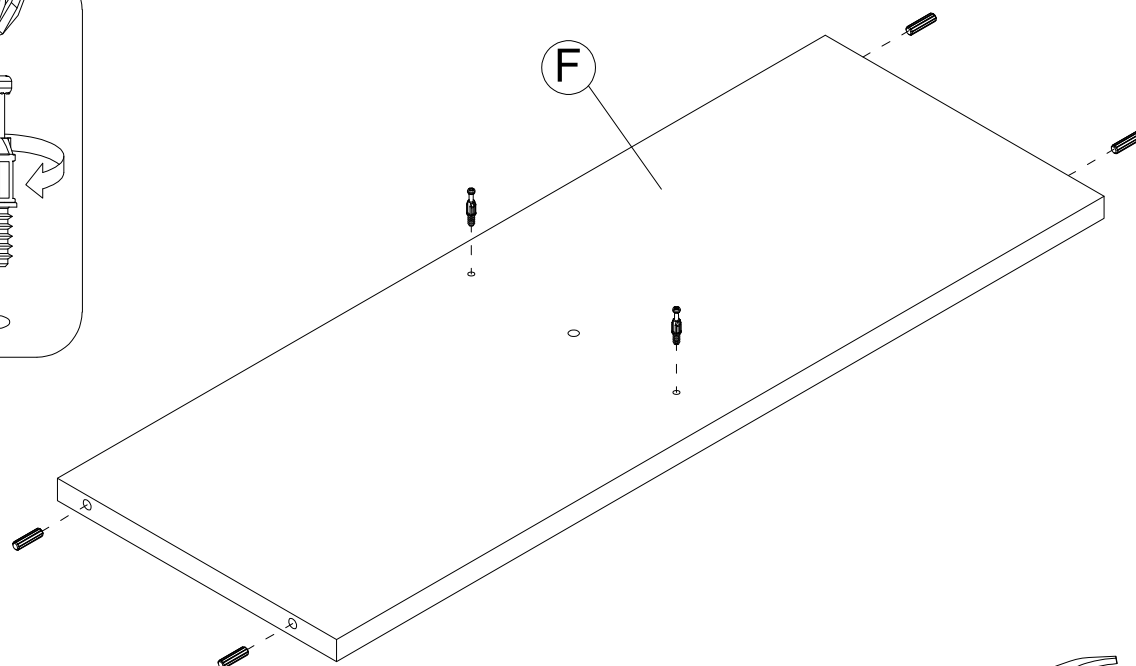
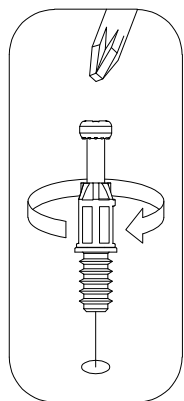

Safety glasses  
Gafas de seguridad  
Lunettes de protection

# STEP 4

# Prepare Panel

H38169



[ 3 ]

Wood Dowel  
8 x 30mm

H72988

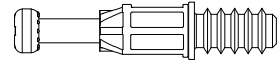

[ 4 ]

KD Bolt

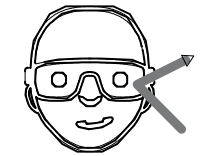
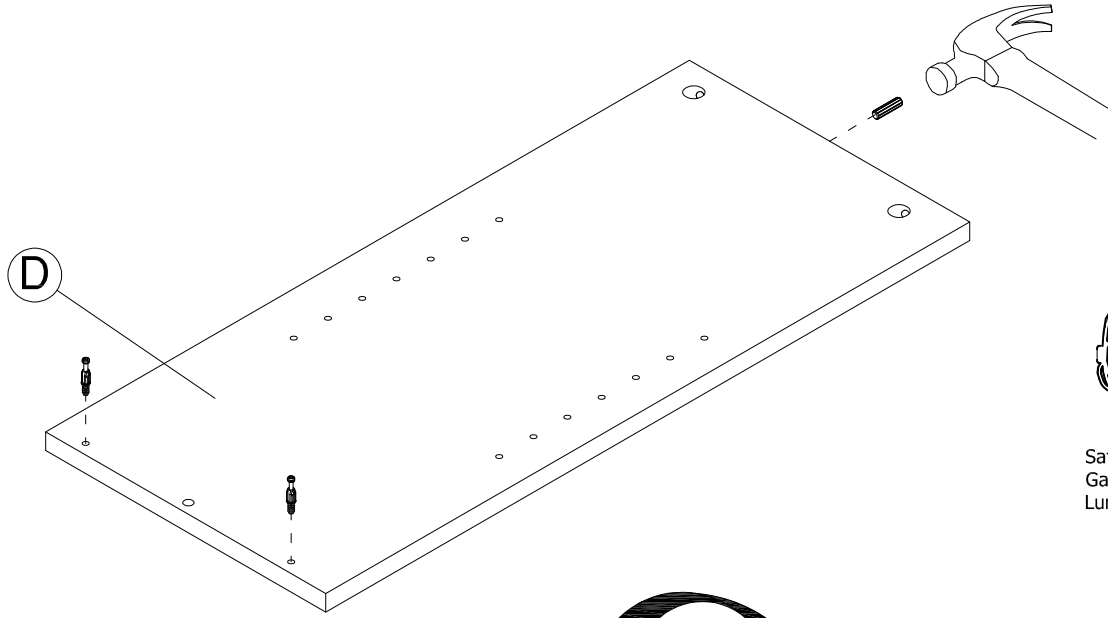

Safety glasses  
Gafas de seguridad  
Lunettes de protection

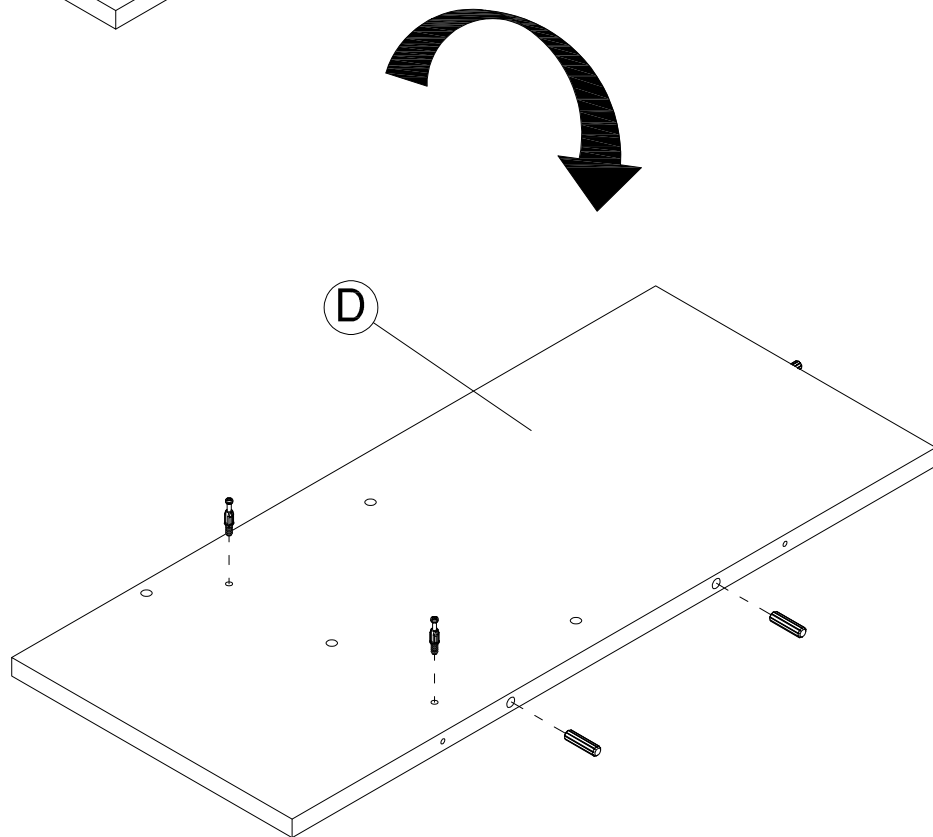
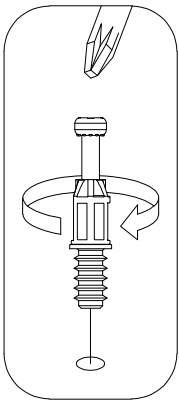

# STEP 5

# Prepare Panel

H38169



[ 3 ]

Wood Dowel  
8 x 30mm

H72988

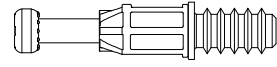

[ 4 ]

KD Bolt

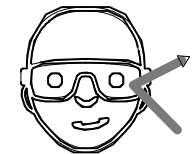
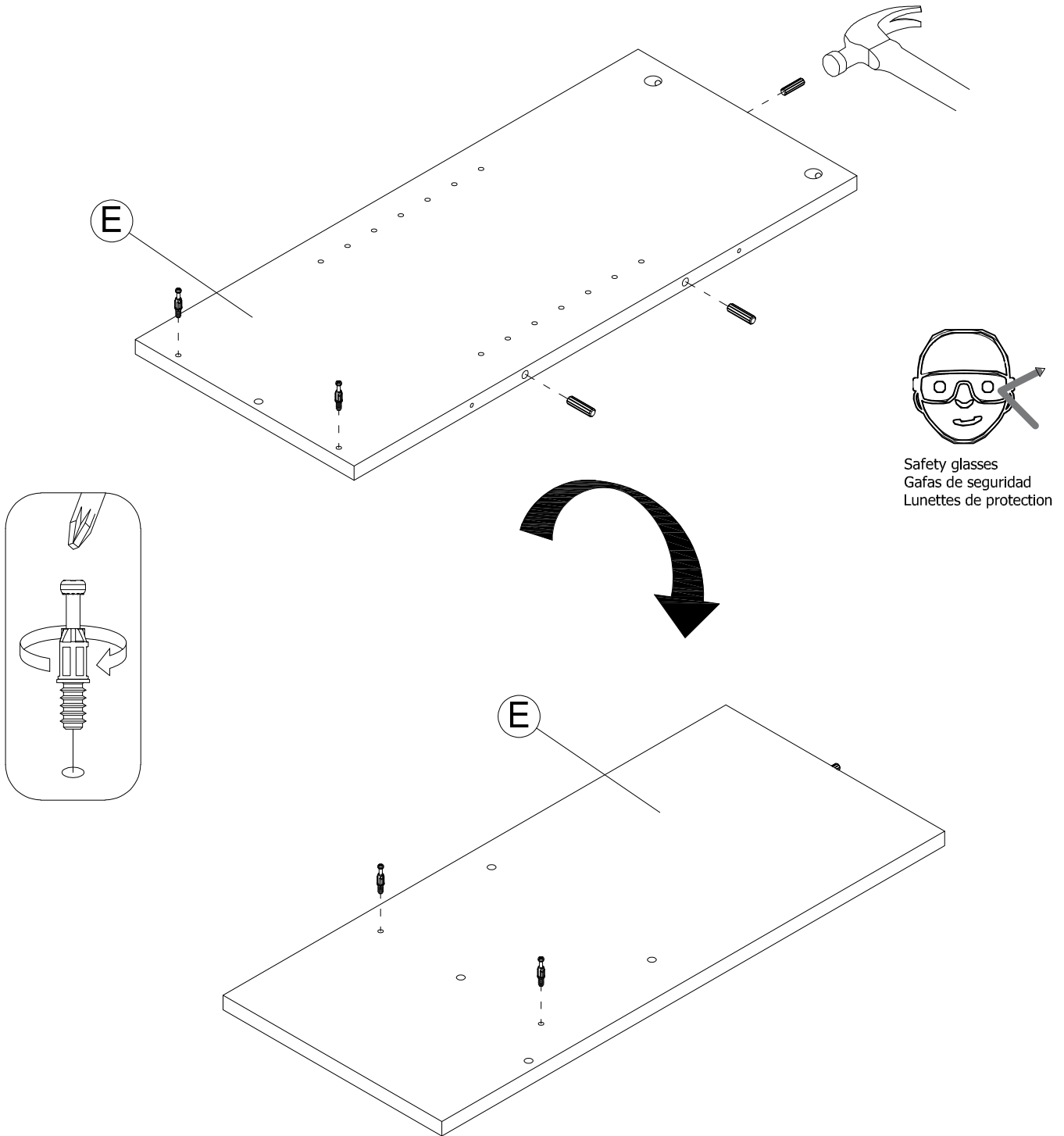

Safety glasses  
Gafas de seguridad  
Lunettes de protection

# STEP 6

## Assemble Panels

H181468

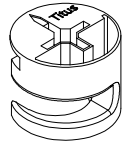

[ 3 ]

KD Cam

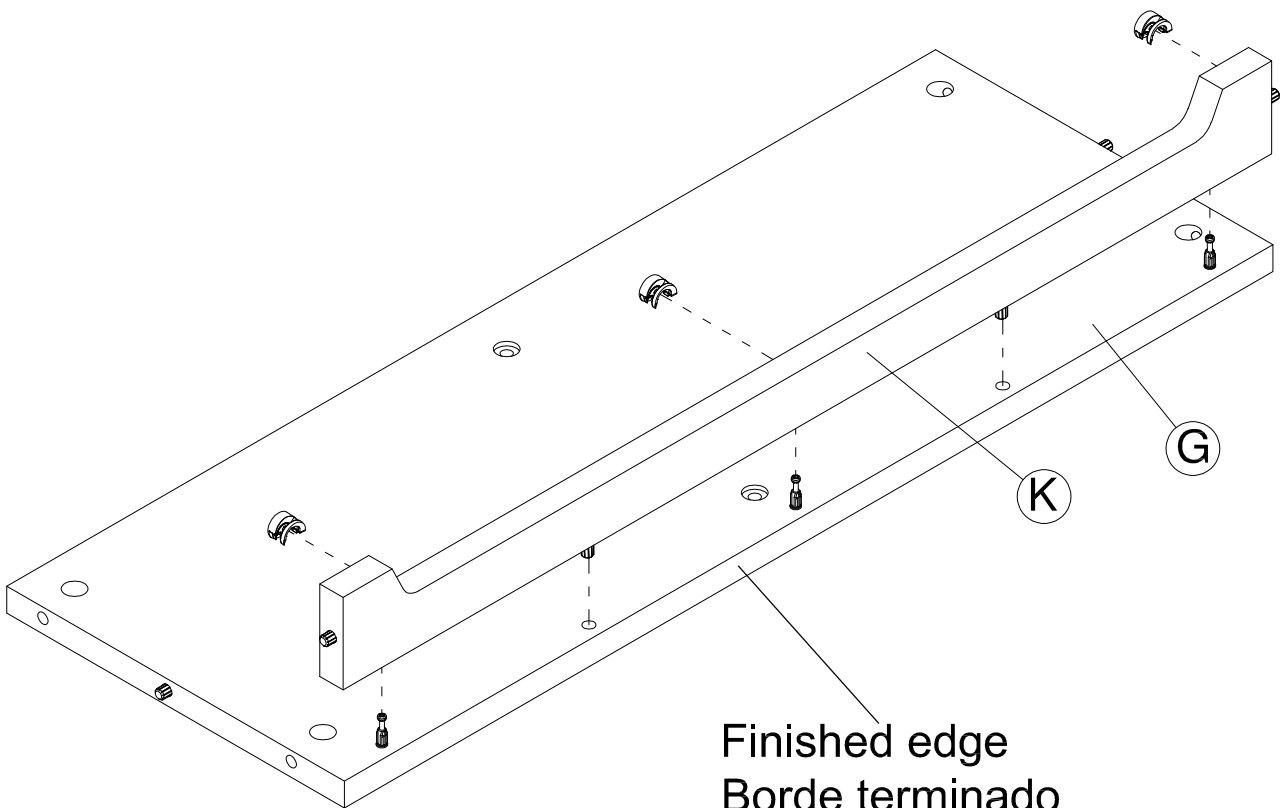
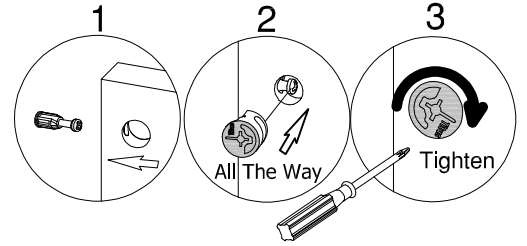

Finished edge  
Borde terminado  
Côté fini

# STEP 7

## Assemble Panels

H181468 [ 2 ]  
KD Cam

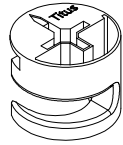

KD Cam

H200203 [ 2 ]  
Cover Cap

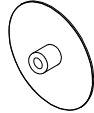

Cover Cap

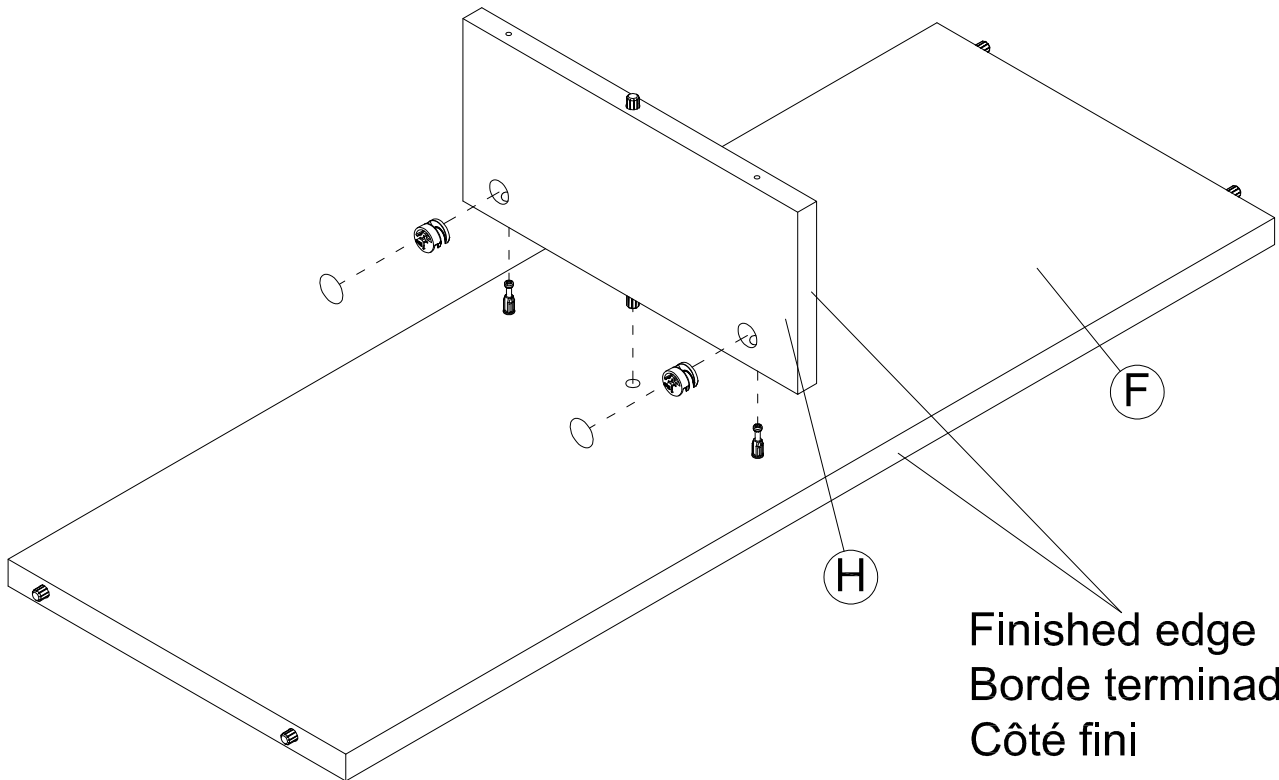
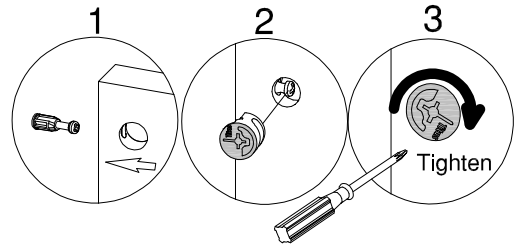

Finished edge  
Borde terminado  
Côté fini

# STEP 8

## Assemble Panels

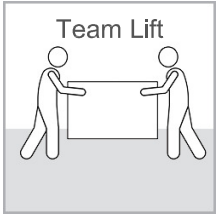

H23198

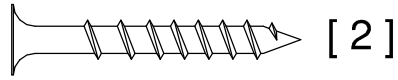

#10 x 1-1/2"

H209492

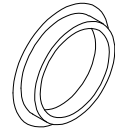

Hole Plug

Finished edge  
Borde terminado  
Côté fini

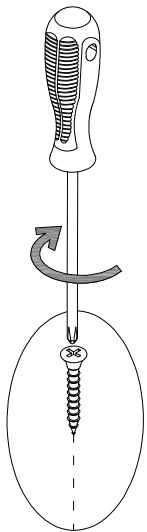
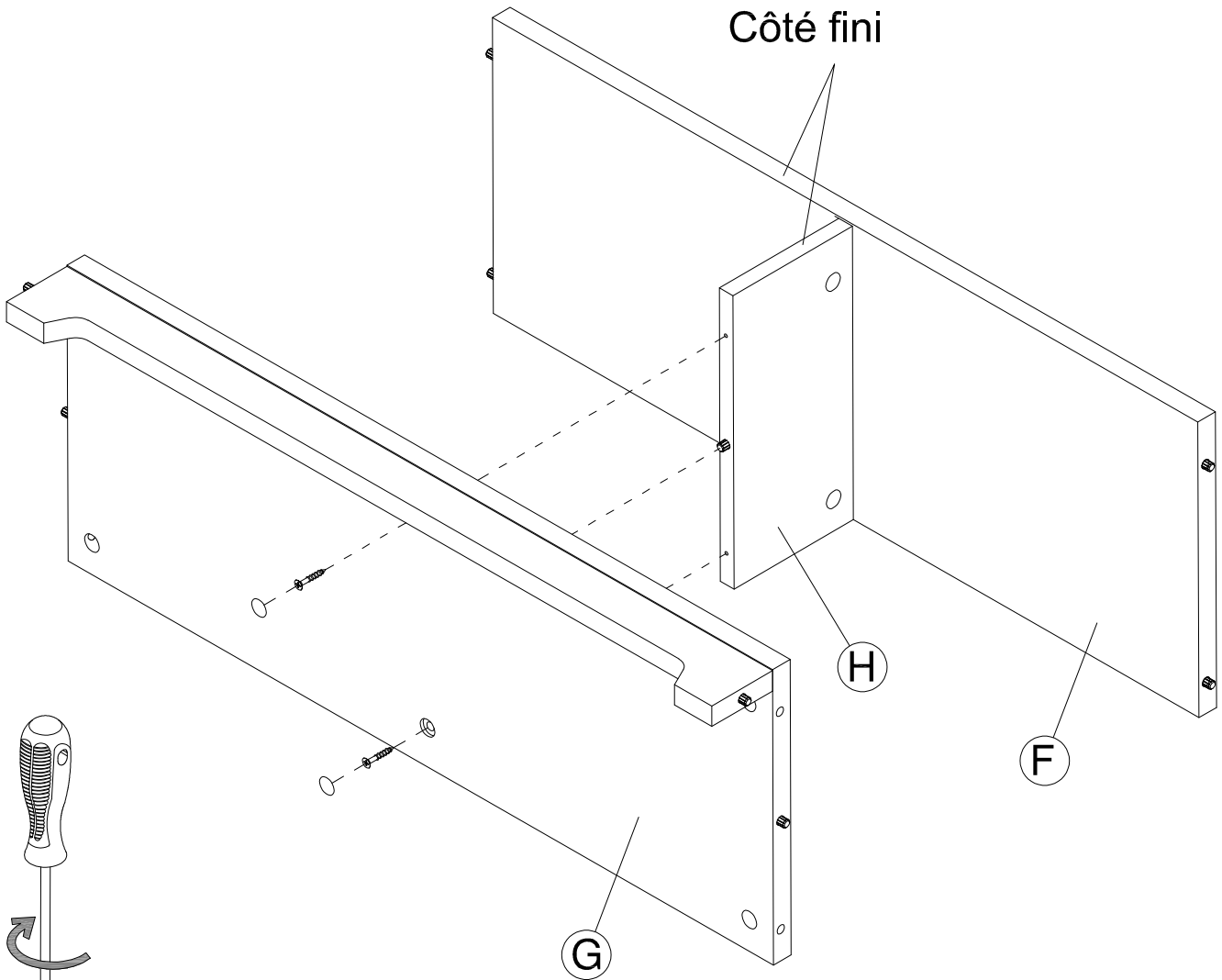

# STEP 9

# Assemble Panels

H181468

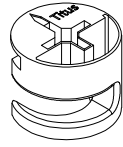

[ 4 ]

KD Cam

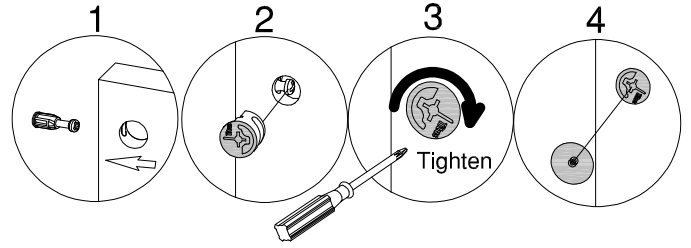

H200203

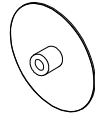

[ 4 ]

Cover Cap

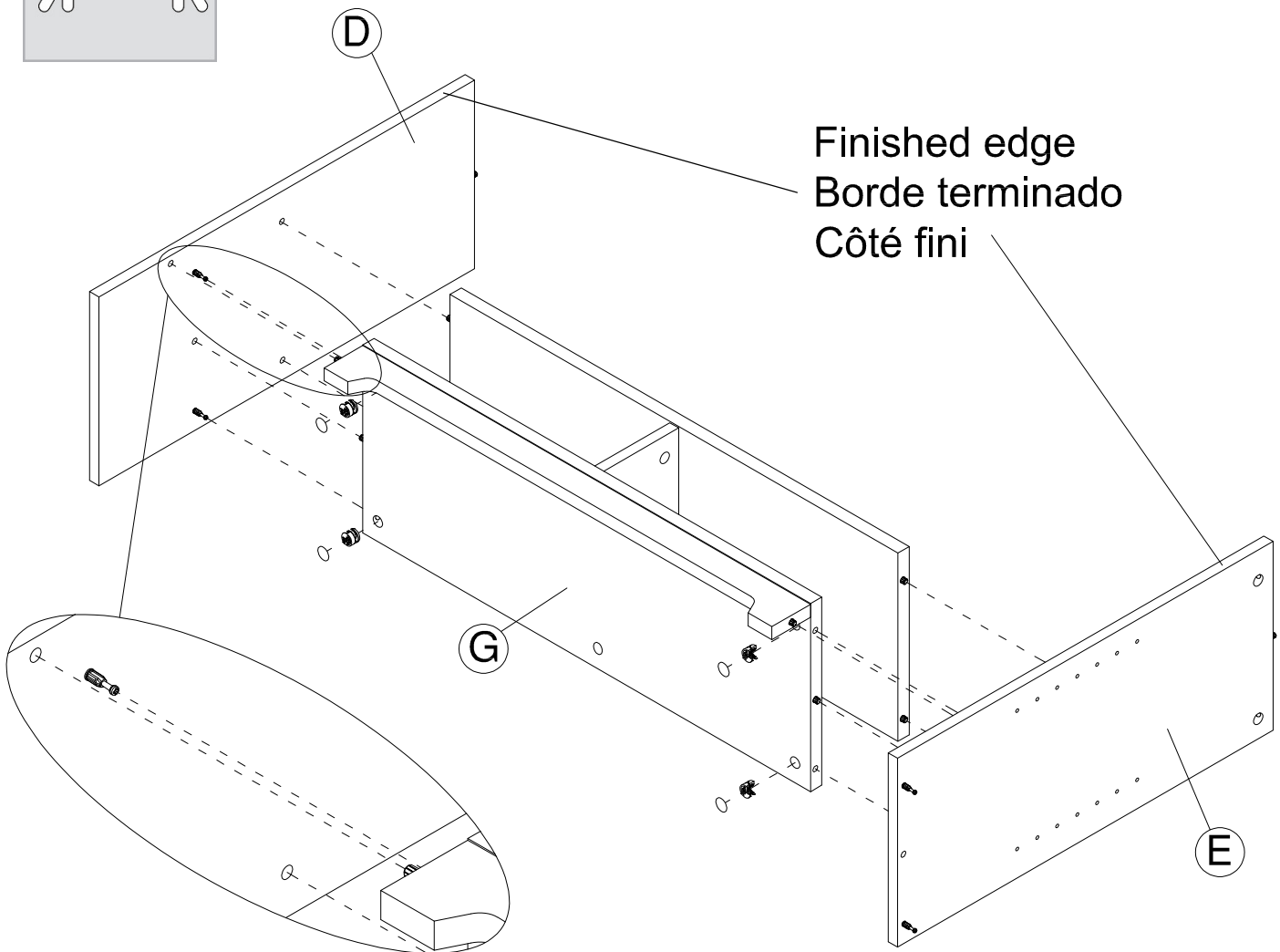
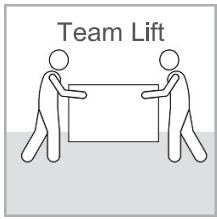

# STEP 10

# Prepare Panels

H38169

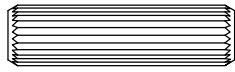

[ 4 ]

Wood Dowel  
8 x 30mm

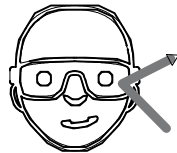

Safety glasses  
Gafas de seguridad  
Lunettes de protection

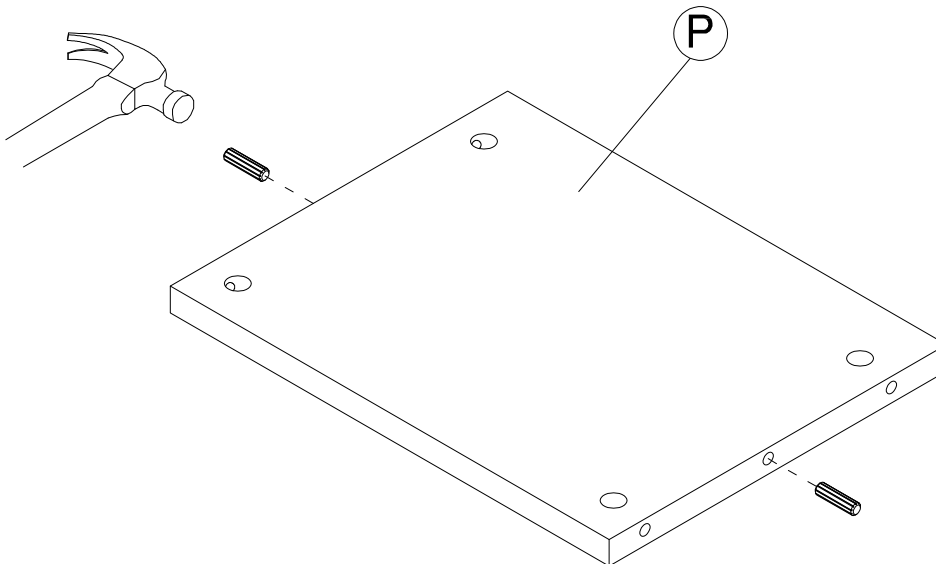

**2 x**

# STEP 11

# Assemble Panels

H181468

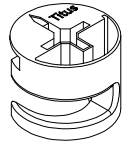

[ 4 ]

KD Cam

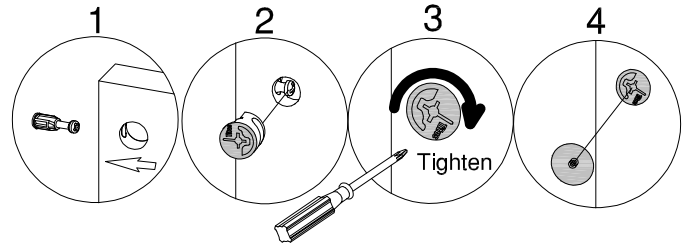

H200203

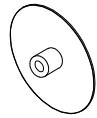

[ 4 ]

Cover Cap

Finished edge  
Borde terminado  
Côté fini

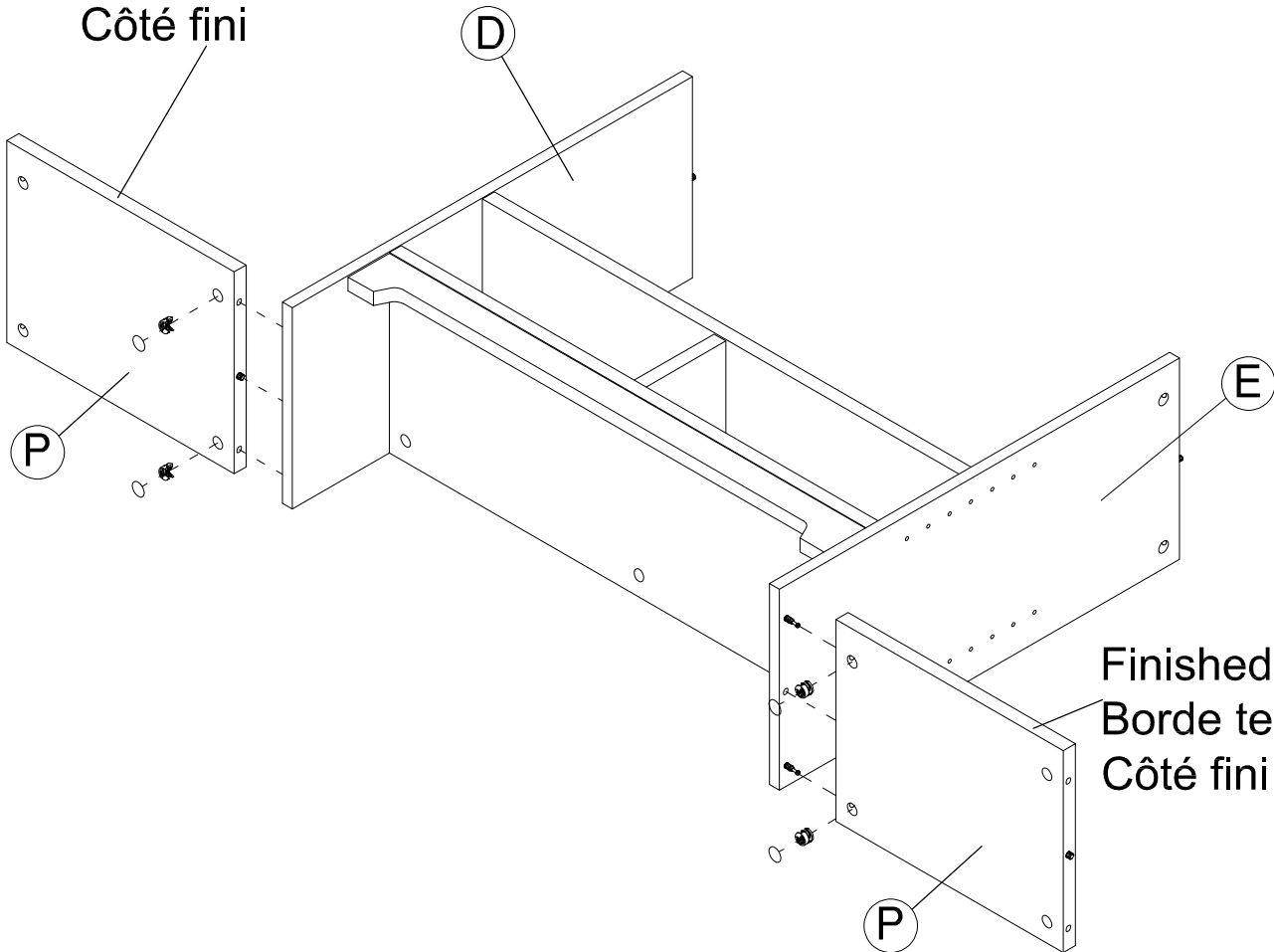

Finished edge  
Borde terminado  
Côté fini

# STEP 12

# Prepare Panels

H38169



[ 13 ]

Wood Dowel  
8 x 30mm

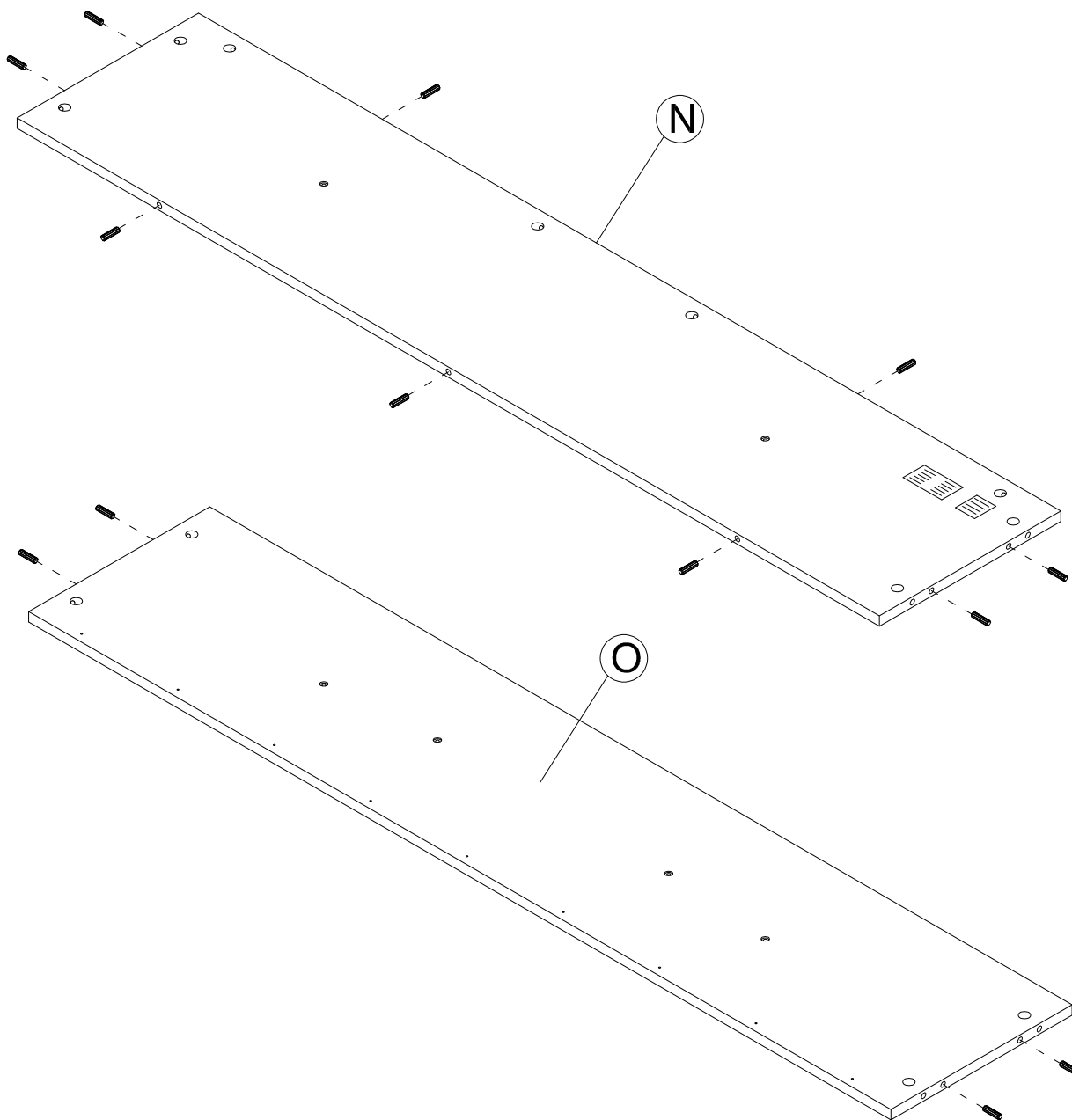

# STEP 13

# Assemble Panels

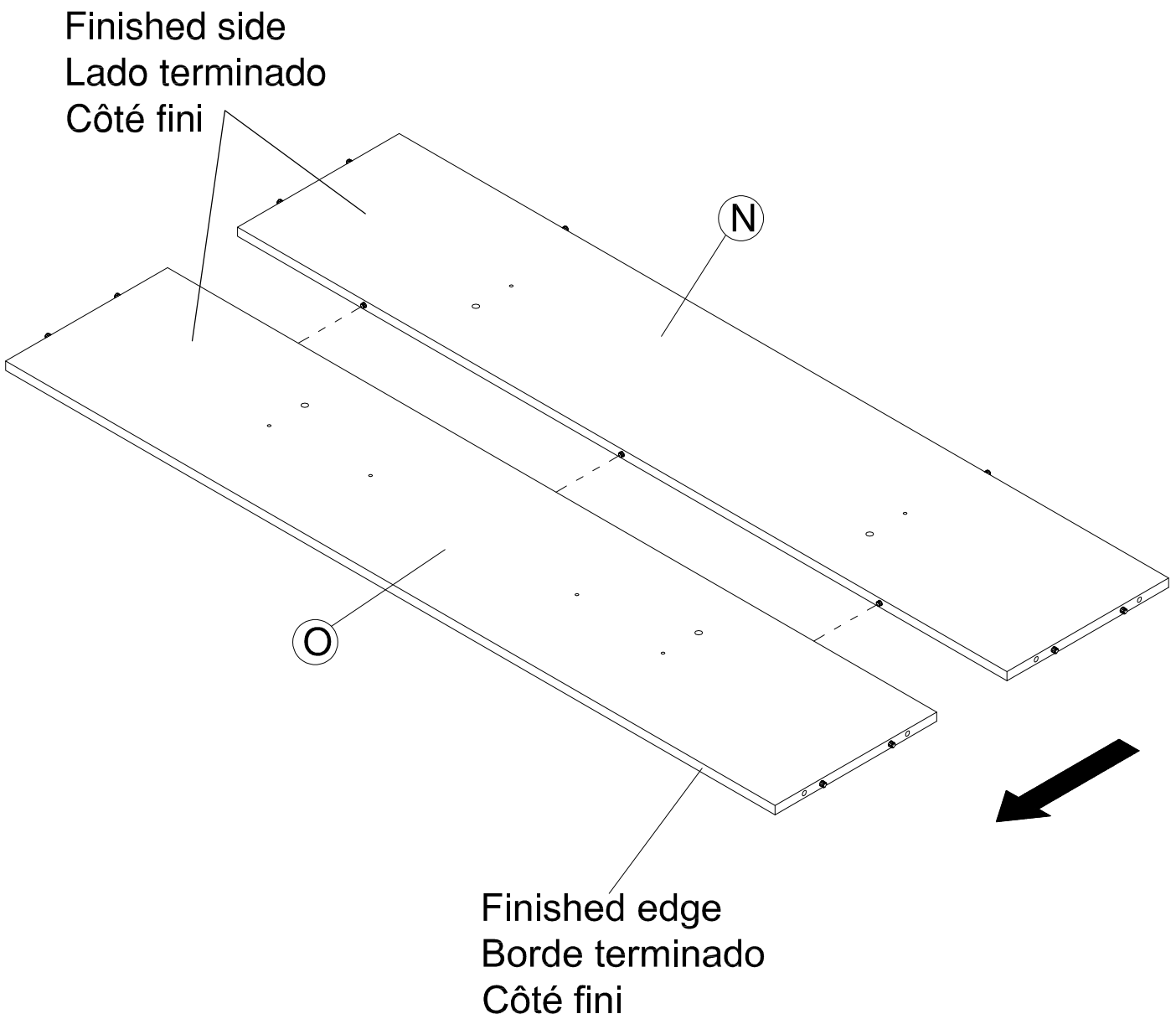
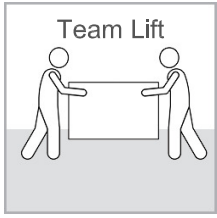

# STEP 14

# Assemble Panels

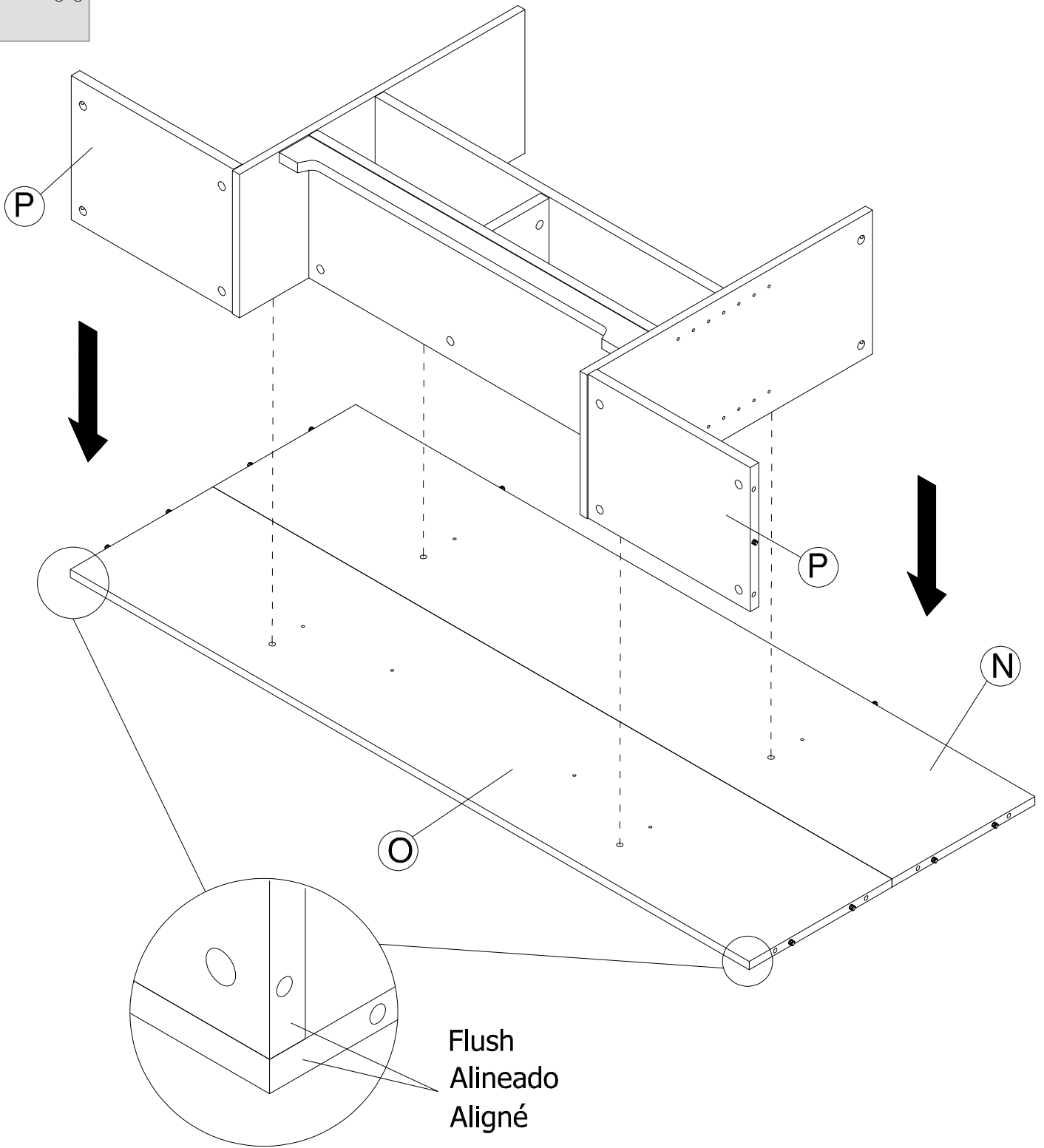
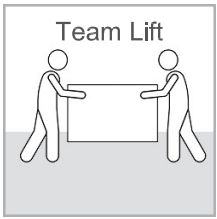

# STEP 15

# Prepare Panel

H170612

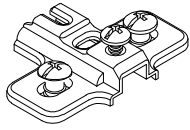

[ 2 ]

Mounting Plate

H38169

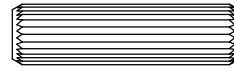

[ 1 ]

Wood Dowel  
8 x 30mm

H72988

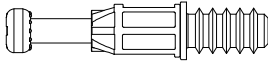

[ 8 ]

KD Bolt

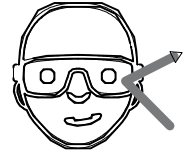

Safety glasses  
Gafas de seguridad  
Lunettes de protection

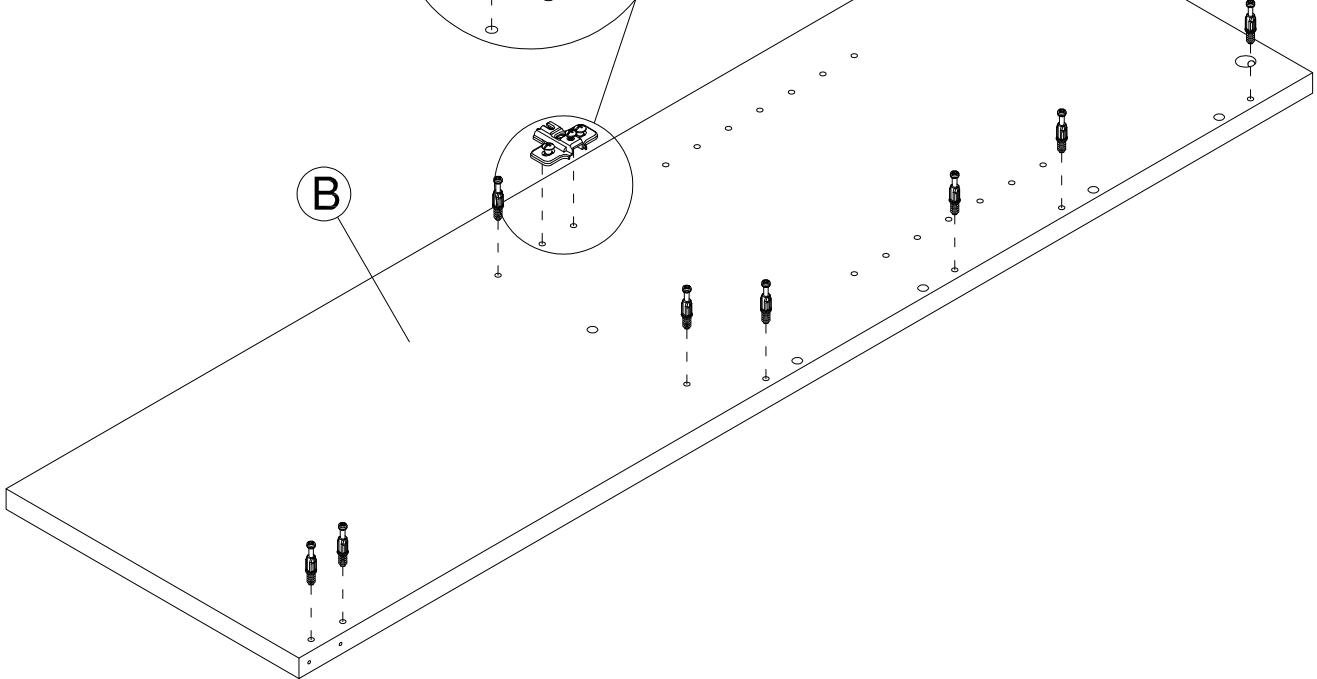
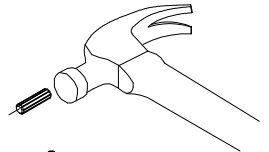
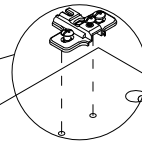
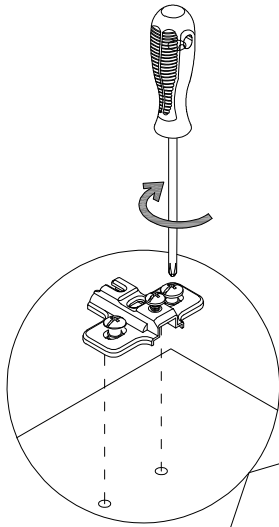
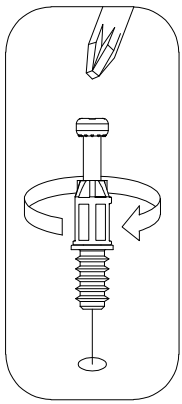

# STEP 16

# Prepare Panel

H170612

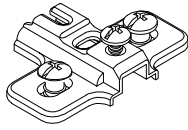

[ 2 ]

Mounting Plate

H38169



[ 1 ]

Wood Dowel  
8 x 30mm

H72988

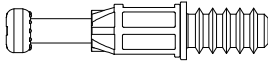

[ 8 ]

KD Bolt

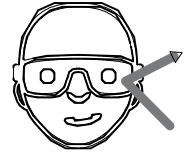

Safety glasses  
Gafas de seguridad  
Lunettes de protection

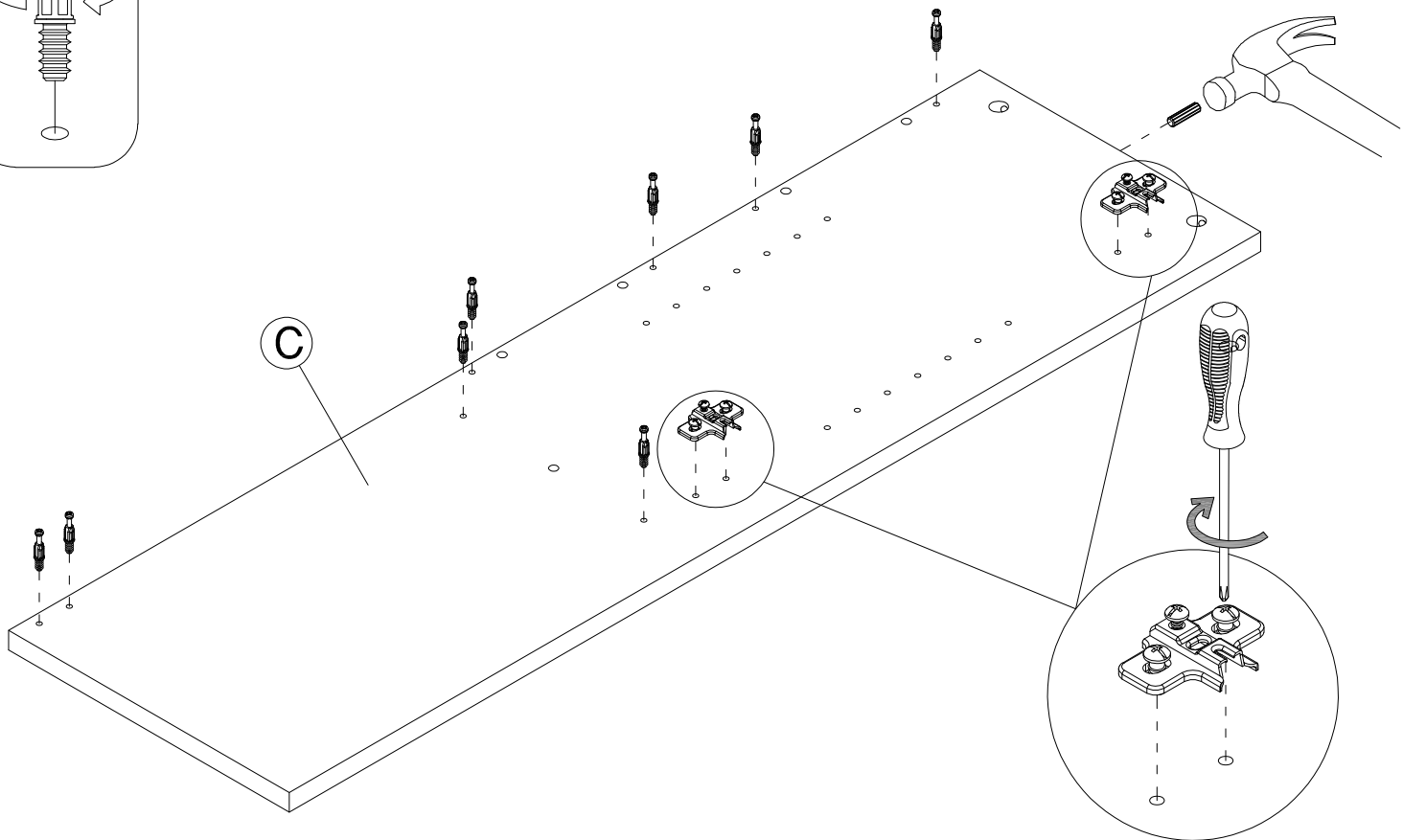
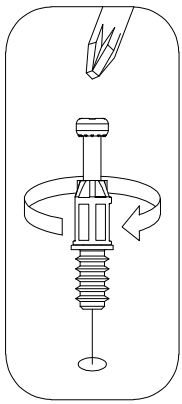

# STEP 17

# Assemble Panels

H181468 [ 2 ]  
KD Cam

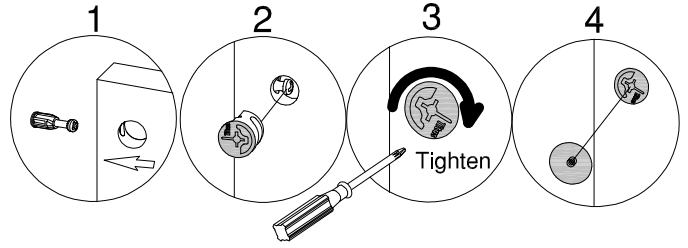

H200203 [ 2 ]  
Cover Cap

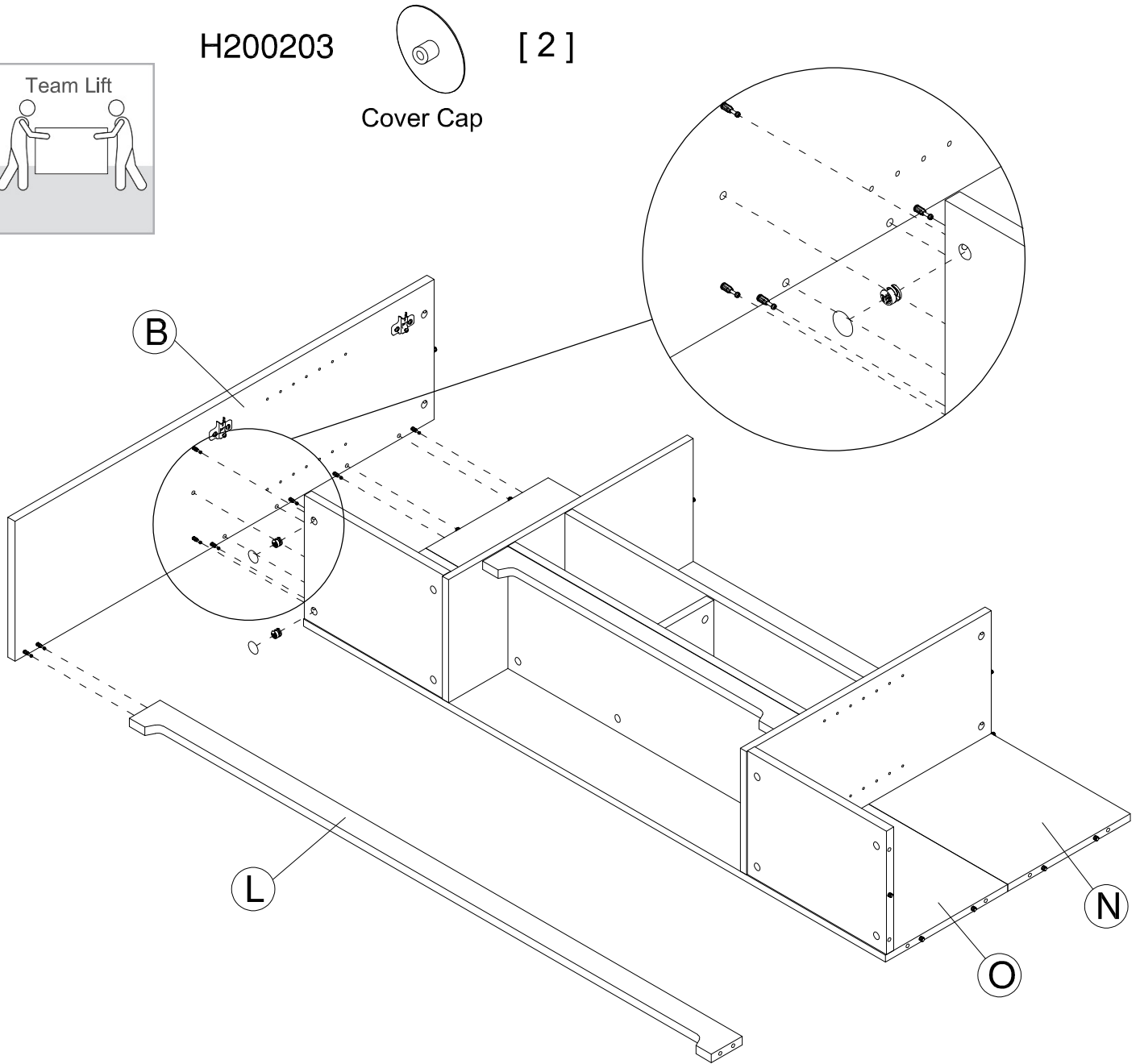
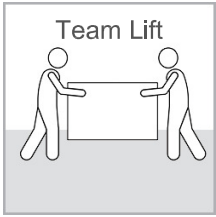

# STEP 18

# Assemble Panels

H181468

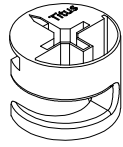

[ 2 ]

KD Cam

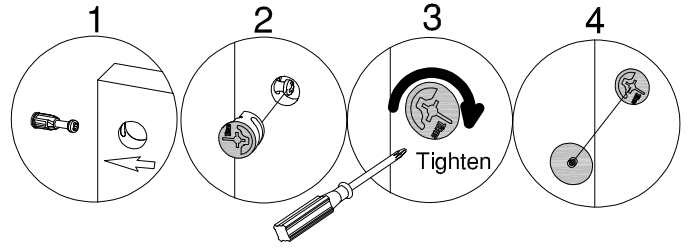

H200203

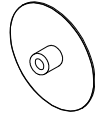

[ 2 ]

Cover Cap

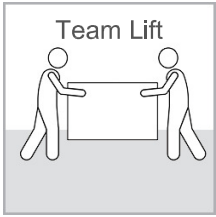

Team Lift

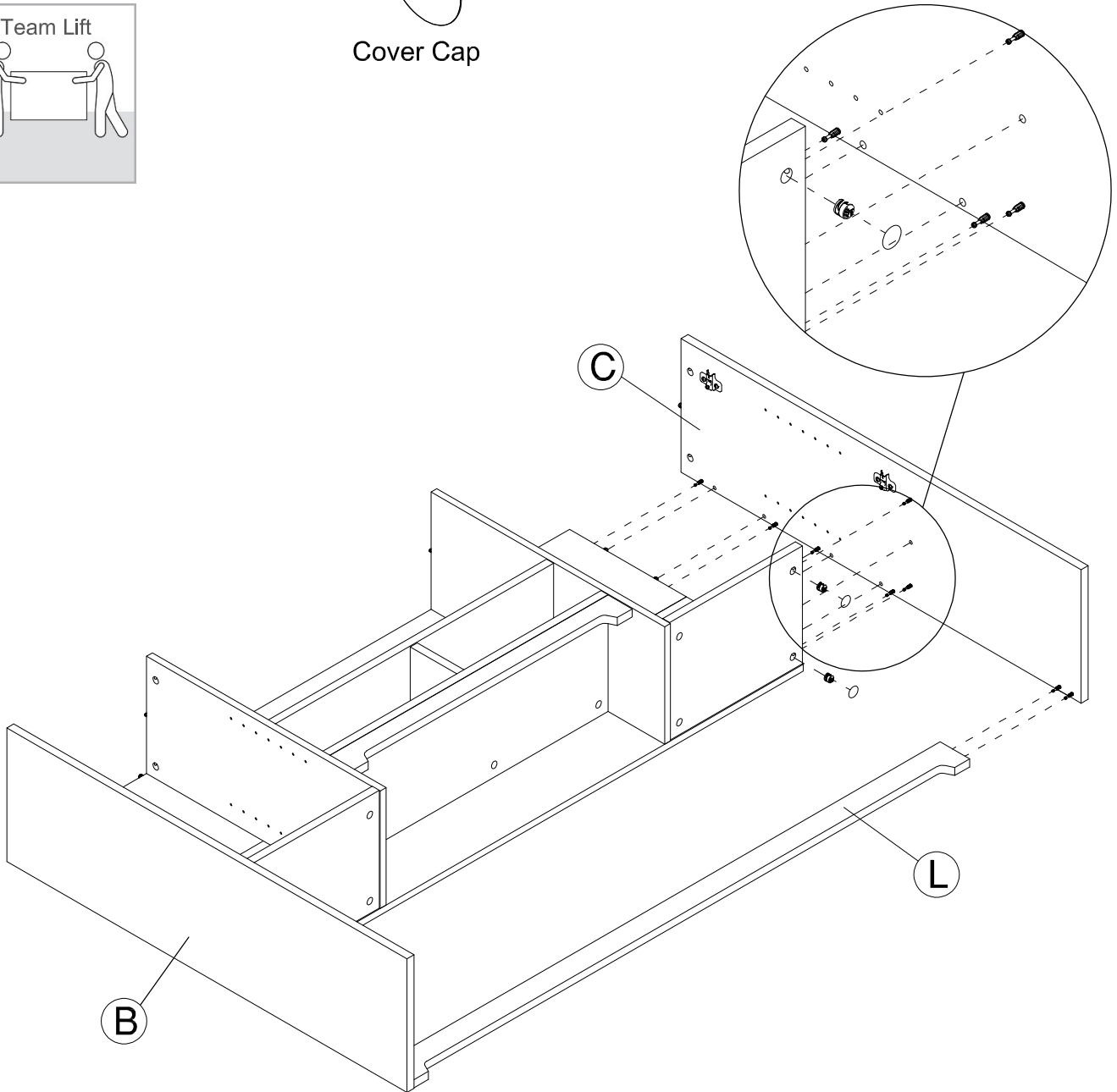

# STEP 19

# Prepare Panel

H72988

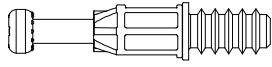

[ 12 ]

KD Bolt

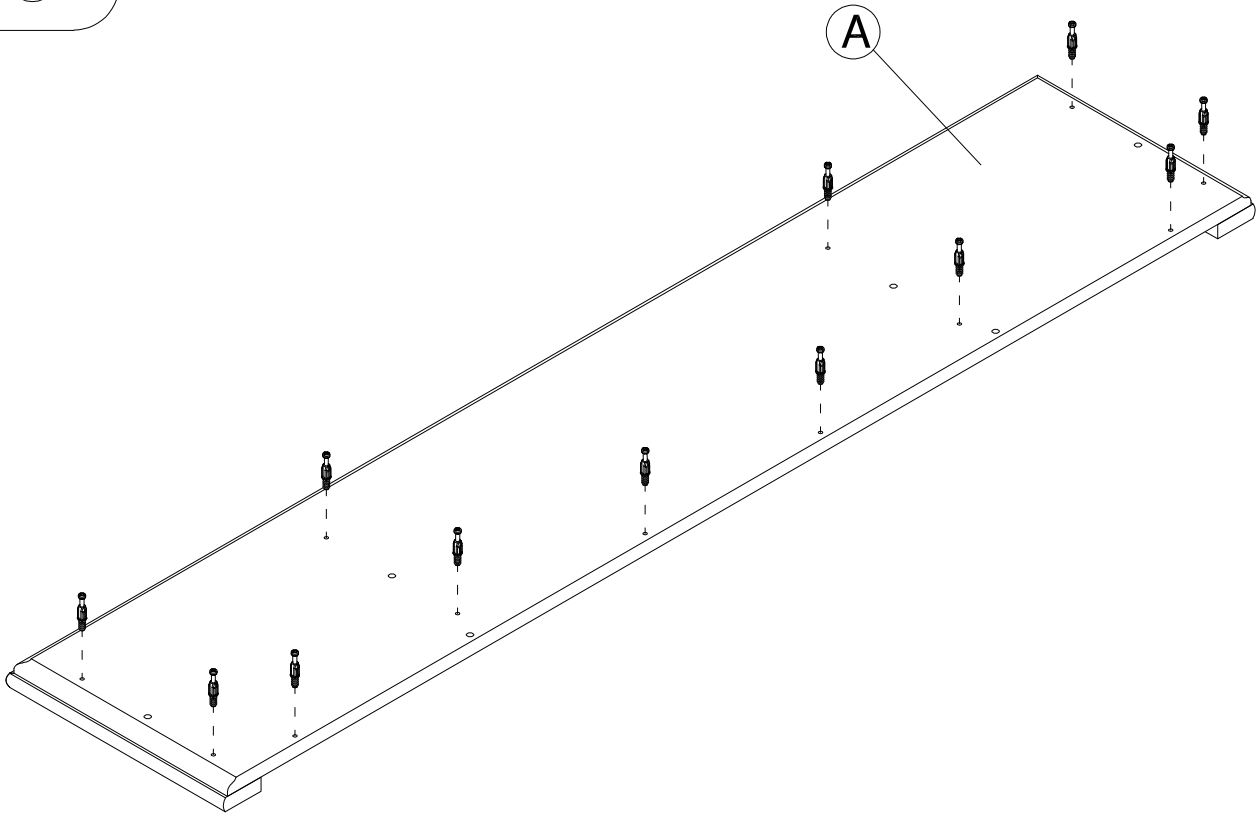
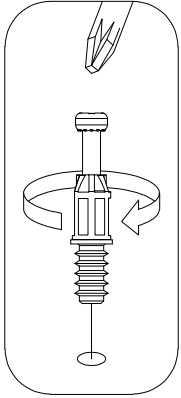

# STEP 20

# Assemble Panels

H181468

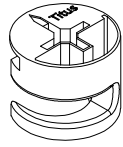

[ 8 ]

KD Cam

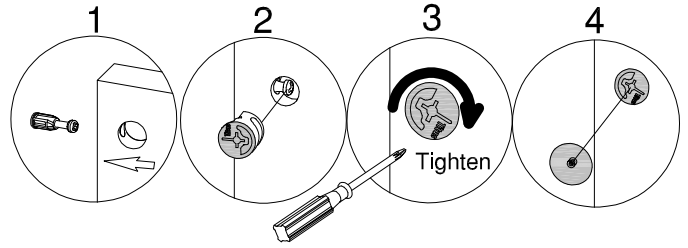

H200203

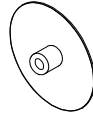

[ 8 ]

Cover Cap

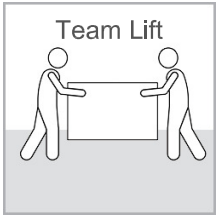

Team Lift

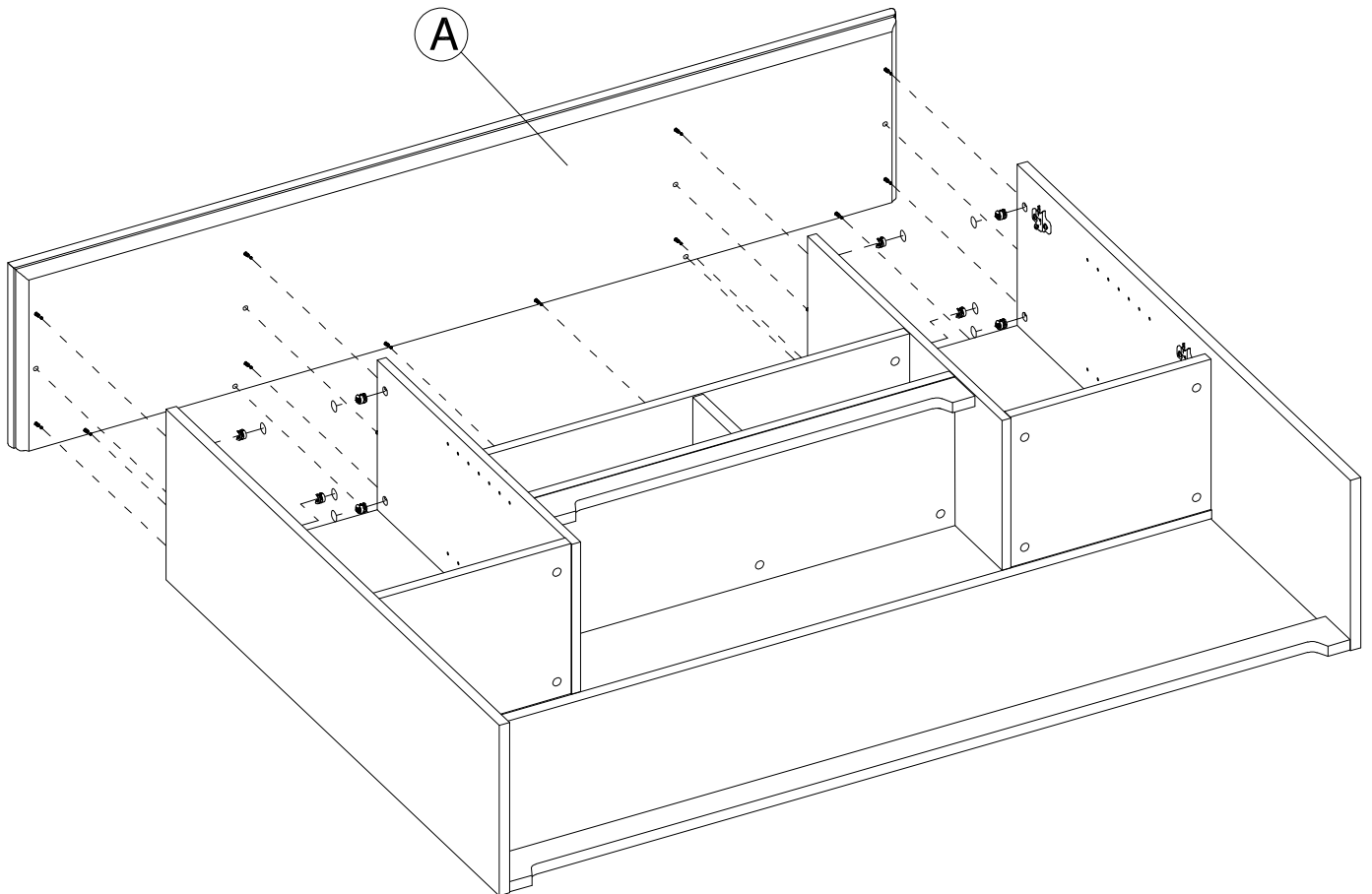

# STEP 21

# Assemble Panels

H181468

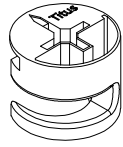

[ 16 ]

KD Cam

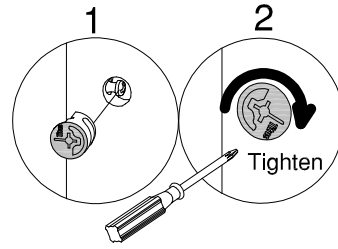

H23198

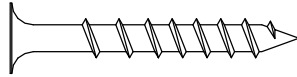

[ 6 ]

#10 x 1-1/2"

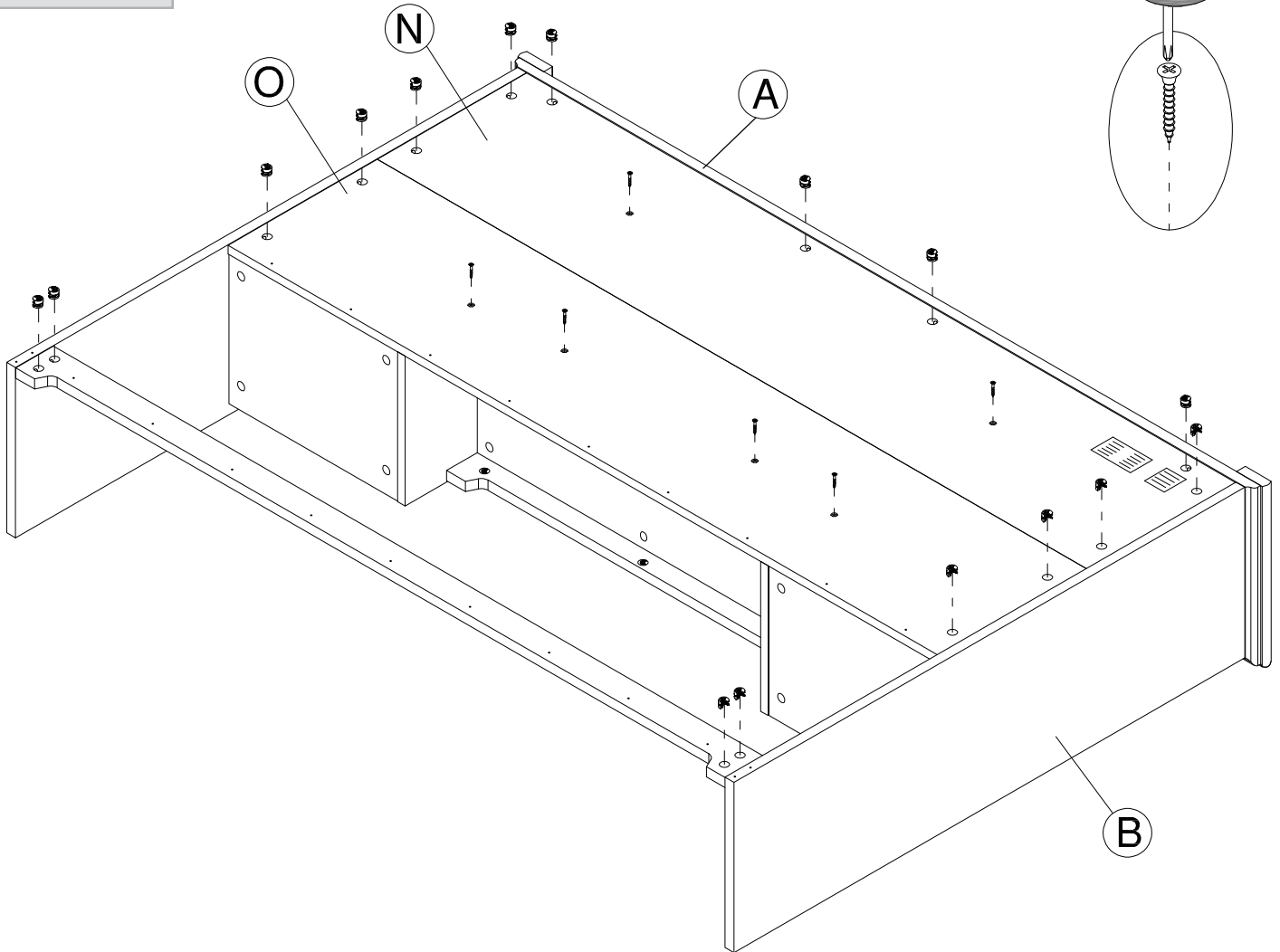
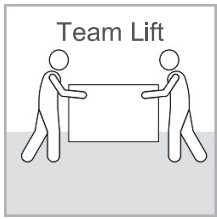
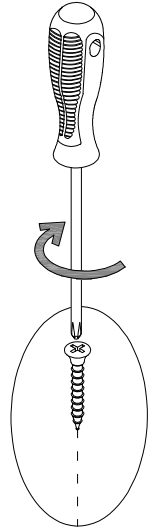

# STEP 22

# Attach Back Panel

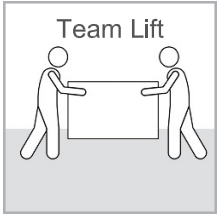

H34174  [ 12 ]  
#3 x 3/4"

H211930  [ 18 ]  
#8 -18x 15/32"

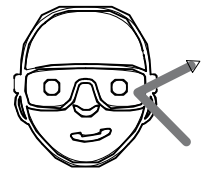
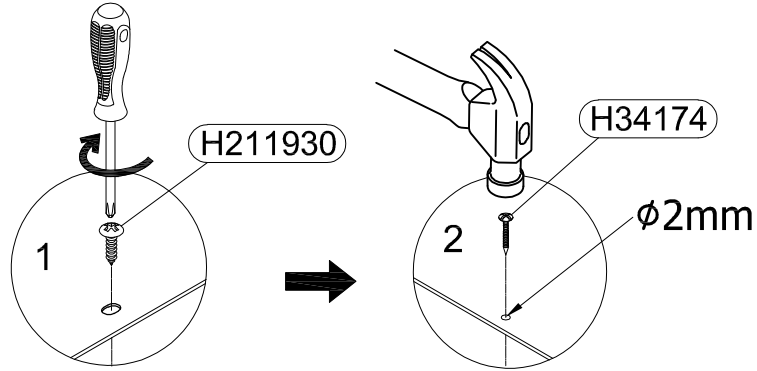

Safety glasses  
Gafas de seguridad  
Lunettes de protection

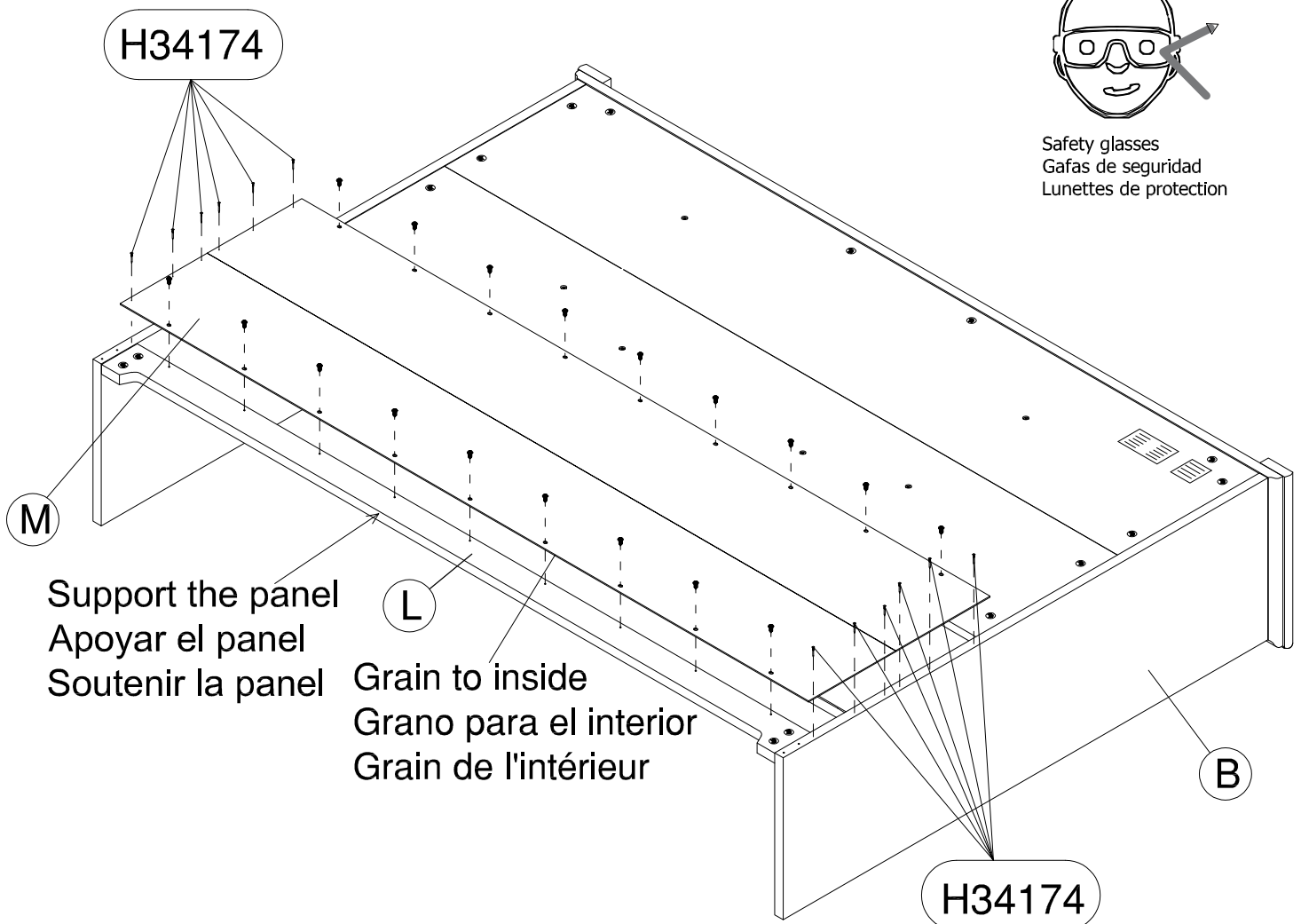

# STEP 23

# Assemble Panels

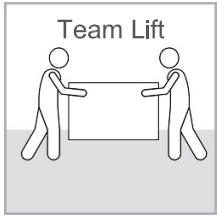

H211039

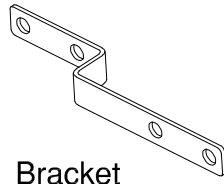

Bracket

[ 2 ]

H23682

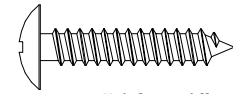

#10 x 1"

[ 8 ]

LEH160LW

LED160LW  
LED260LW

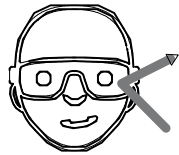
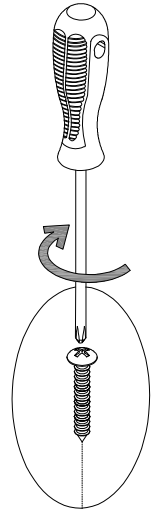
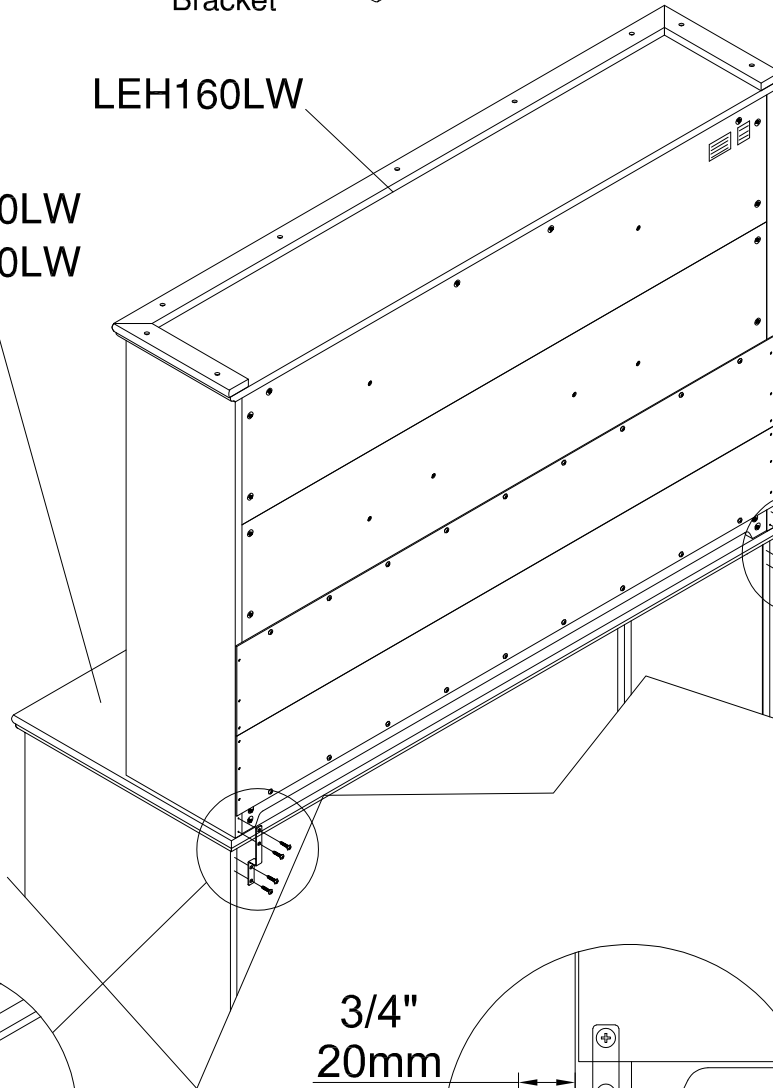

Safety glasses  
Gafas de seguridad  
Lunettes de protection

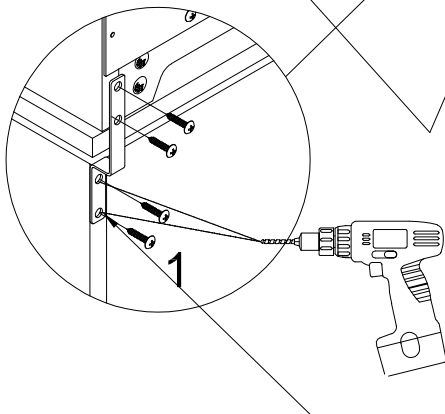

3/4"  
20mm

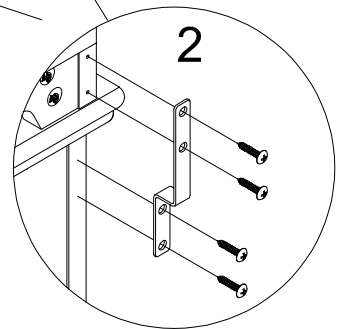
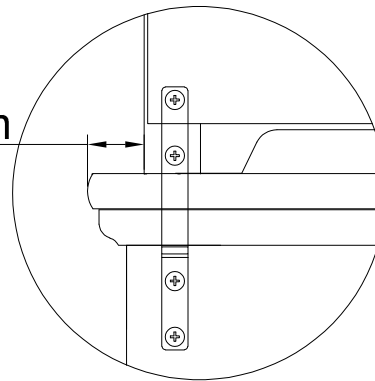

Drill (4) 1/8" holes 3/4" deep.

Perfore (4) agujeros de 3mm a 19mm de profundido.

Percer (4) trous de 3mm de diamètre et 19mm de profondeur.

## STEP 24

## Wall Attachment

Secure unit to the wall with a tip-over restraint.

Unidad de seguro a la pared con un sistema de retención de un vuelco.

Fixer l'unité au mur avec un dispositif de retenue renversement.

1. Place unit in desired location.
2. Locate wall stud nearest unit center. **FIG A**
3. On wall, mark center of stud location 1" below top of unit. **FIG A**
4. If a wall stud cannot be located mark hollow wall at unit center. **FIG A**
5. On back of unit, mark corresponding location 3/8" below top of unit. **FIG B**

1. Coloque la unidad en el lugar deseado.
2. Localice pie derecho de pared centro de unidad más próxima.
3. En la pared del, marque el centro de la ubicación del montante 1 "abajo la parte superior de la unidad.
4. Si un poste de la pared no se puede localizar marcar pared hueca en el centro de la unidad.
5. En el dorso de la unidad, marque la ubicación 3/8 correspondiente abajo la parte superior de la unidad.

1. Placez l'unité à l'endroit désiré.
2. Localiser centre d'unité la plus proche de la paroi Stud.
3. Sur le mur, centre de emplacement du montant 1 "ci-dessous dessus de l'appareil de la marque.
4. Si un montant de mur ne peut pas être situé marquer mur creux au centre de l'unité.
5. Le dos de l'appareil, marquer l'emplacement 3/8 correspondant ci-dessous dessus de l'appareil.

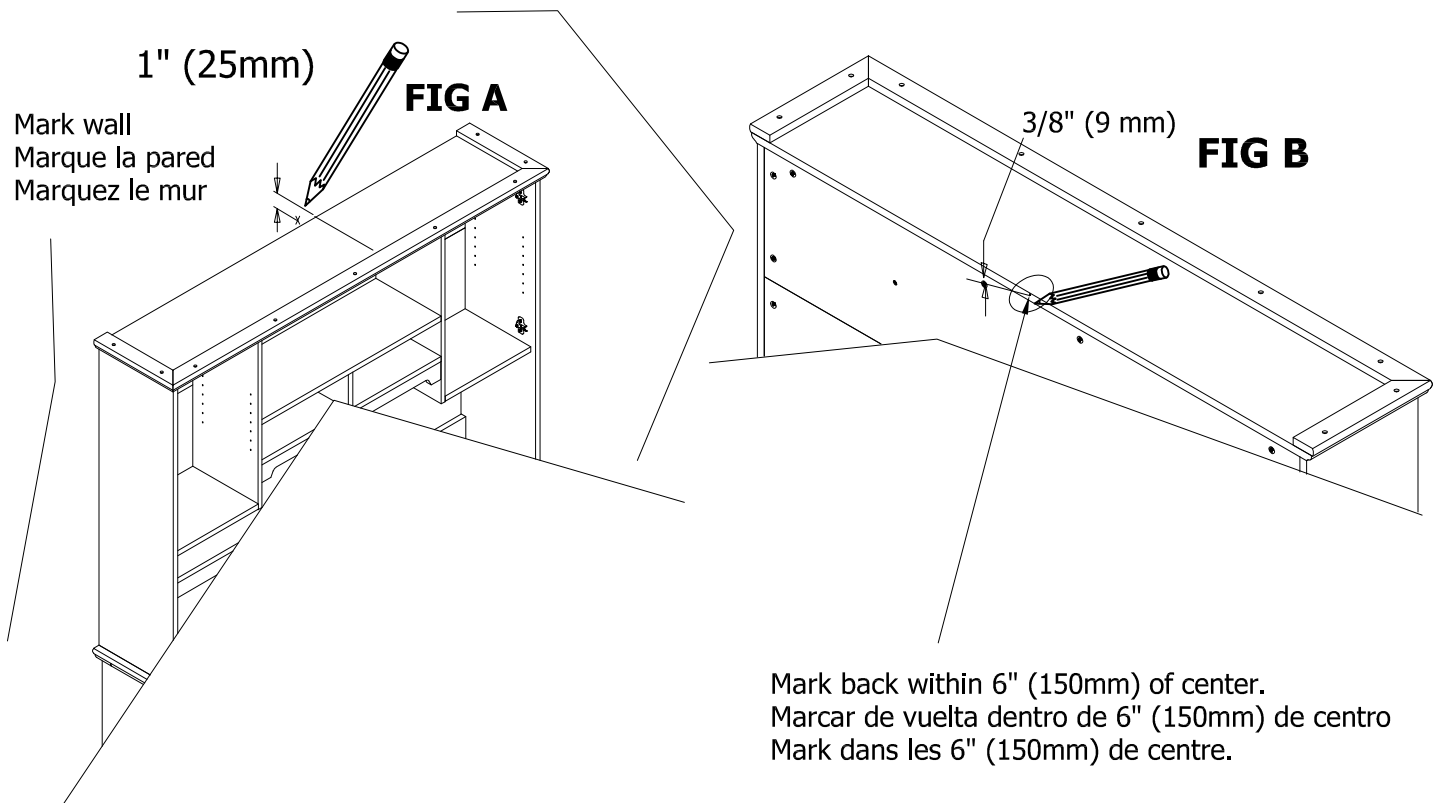

## WALL STUD ATTACHMENT

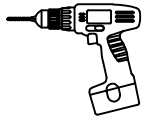

Drill 1/8" hole 2" deep at mark on wall.

Taladro 1/8 "agujero 2" de profundidad en la marca en la pared.

Percer 1/8 "trou de 2" de profondeur à la marque sur le mur.

H181434

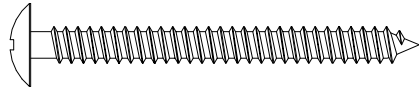

[ 1 ]

#10x2"

H181412

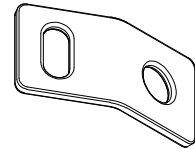

[ 1 ]

Connecting Plate

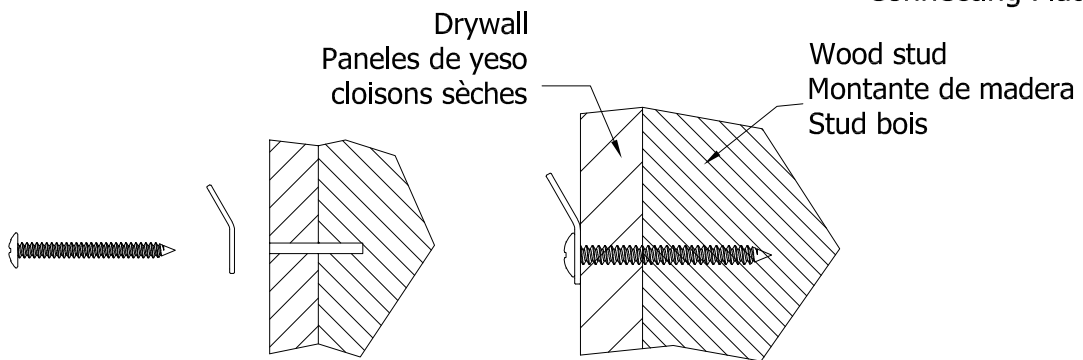

## HOLLOW WALL ATTACHMENT

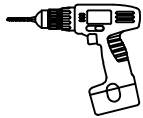

Drill 1/2" hole 1" deep at mark on wall.

Taladro 1/2 "agujero 1" de profundidad en la marca en la pared.

Percer 1/2 "trou de 1" de profondeur à la marque sur le mur.

H181419

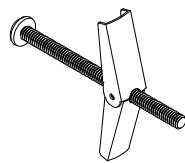

[ 1 ]

Toggle Bolt

H181412

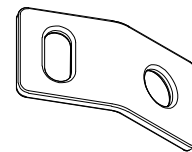

[ 1 ]

Connecting Plate

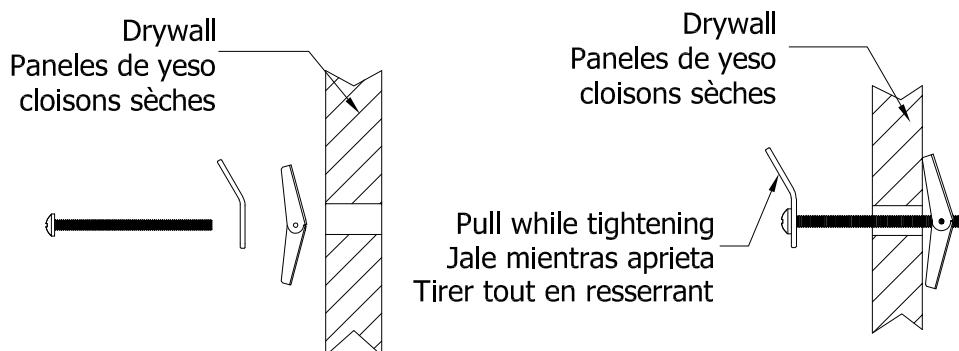

# STEP 26

# Wall Attachment

H107572  [ 1 ]  
#8x1-1/2"

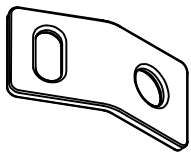
H181412  [ 1 ]  
Connecting Plate

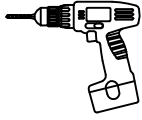

Drill 1/8" hole 1-1/4" deep at mark on unit.  
Taladro 1/8 "agujero de 1-1/4" de profundidad en la marca de la unidad.  
Perçer 1/8 "trou 1-1/4" de profondeur à la marque sur l'unité.

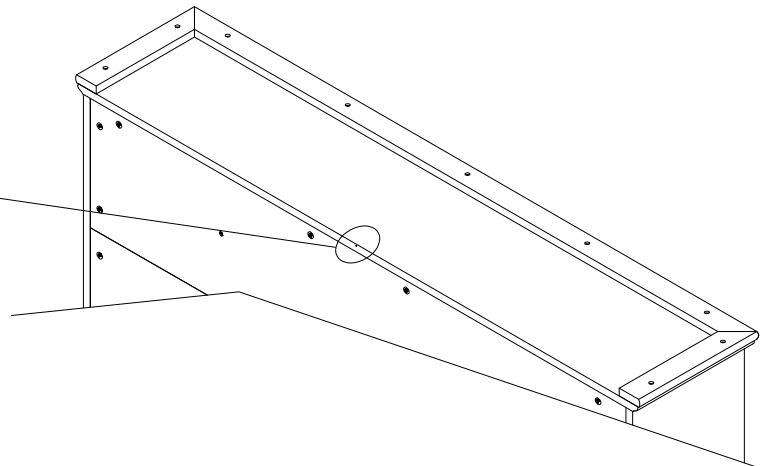
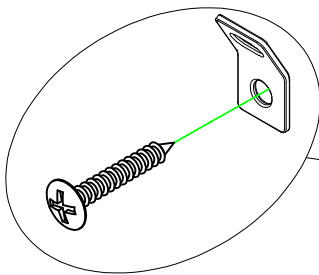

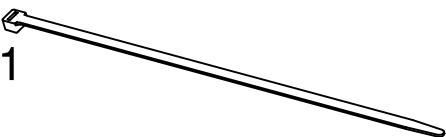
H181411  [ 1 ]  
Nylon Cable Tie

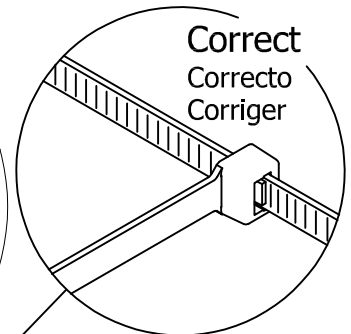
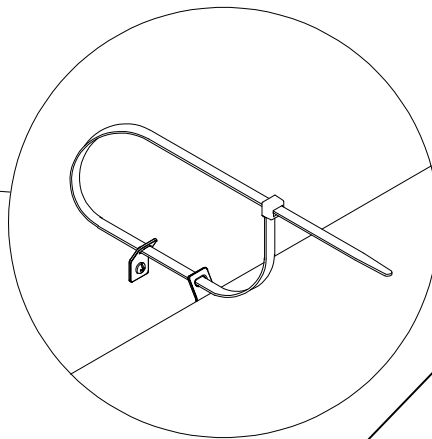
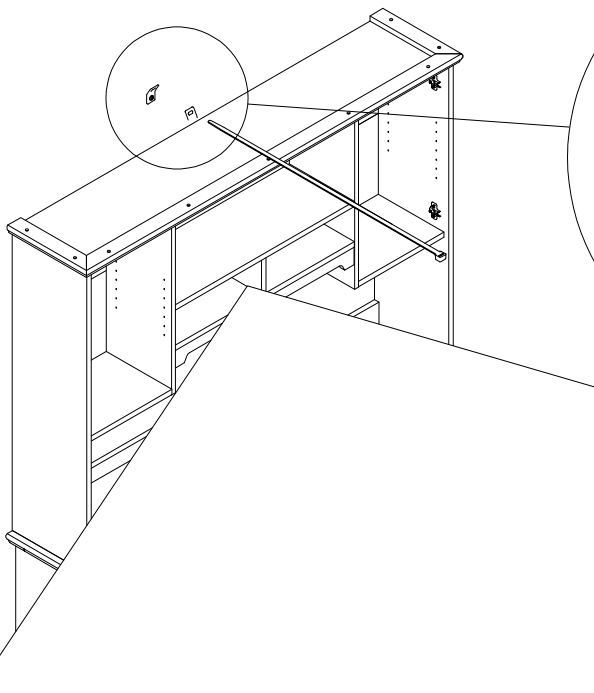

Correct  
Correcto  
Corriger

Pull to verify lock  
Tire para verificar cerradura  
Tirez pour vérifier serrure

Use replacement cable tie with minimum breaking strength of 120lbs.  
Utilice reemplazo empate Cable con resistencia a la rotura mínima de 120 libras.  
Utilisez remplacement Attache de câble avec une force de rupture minimale de 120 lbs.

# STEP 27

# Assemble Panels

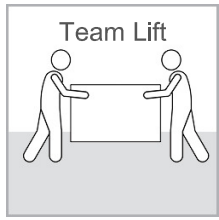

H158707

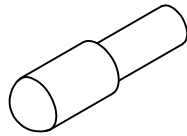

Shelf Pin

[ 8 ]

H149989

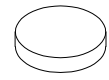

Bumper

[ 4 ]

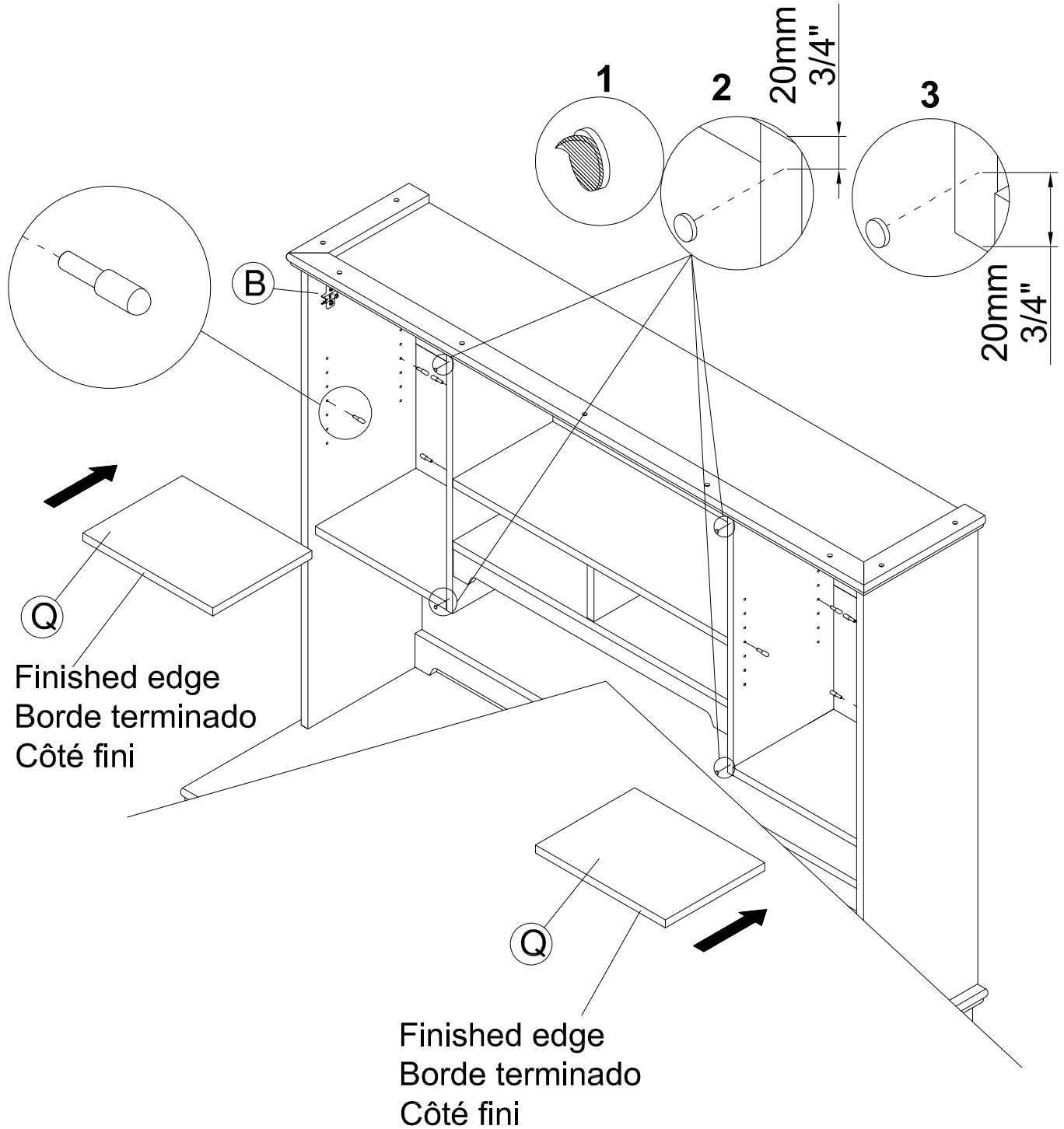

# STEP 28

# Attach Doors

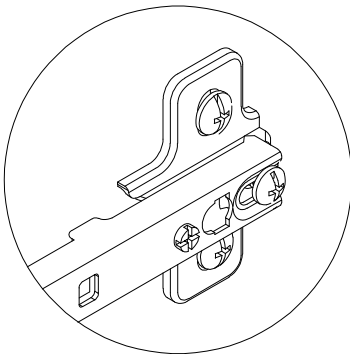
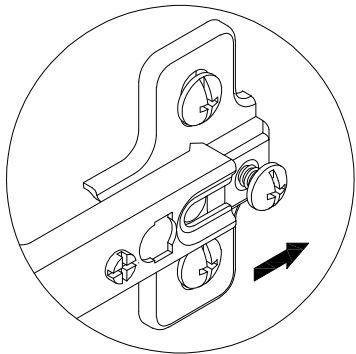
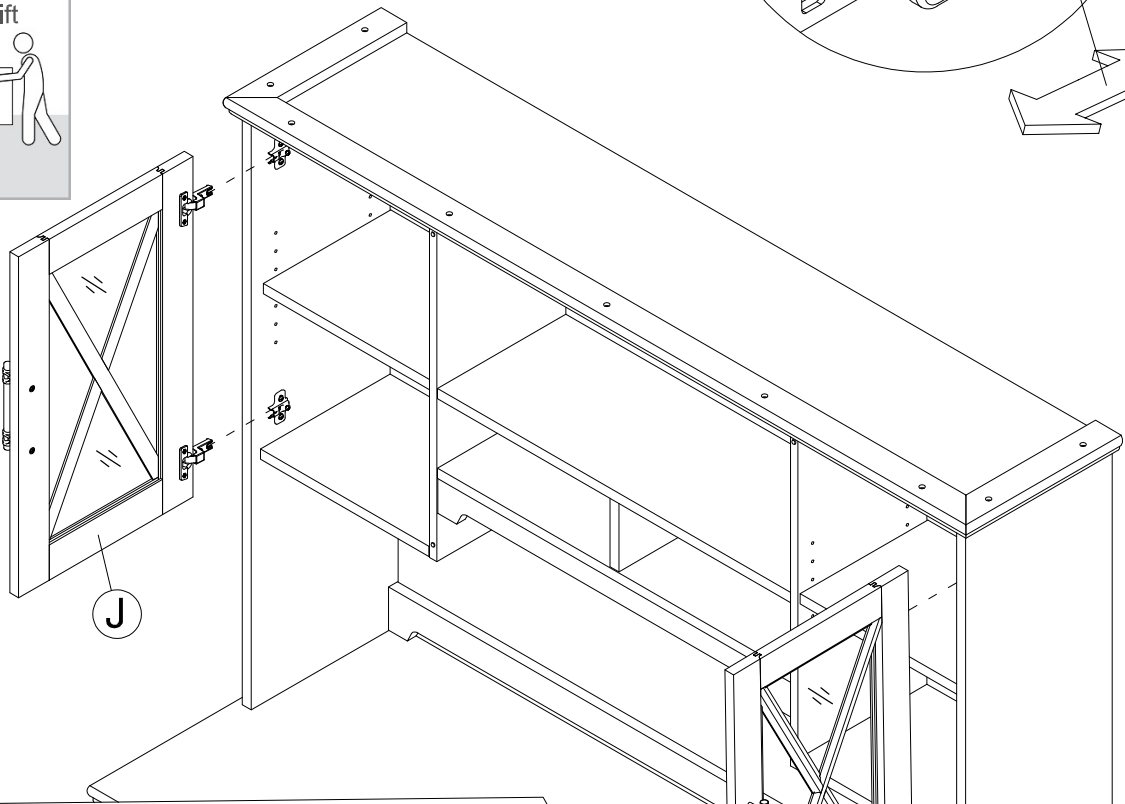
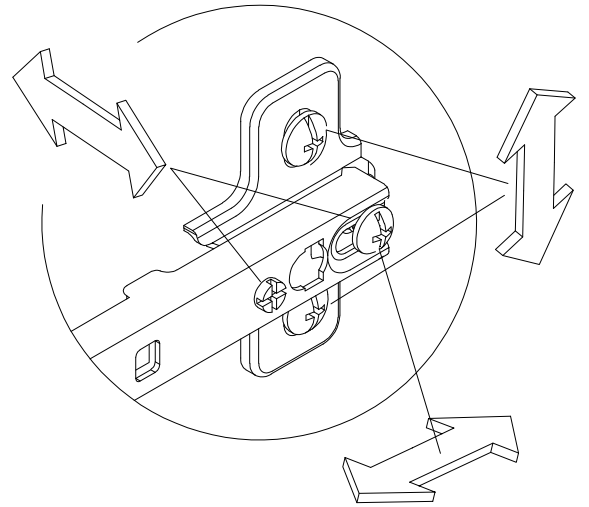
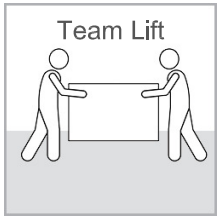

# STEP 29

# Maximum Loading and Cleaning

Gently clean surfaces with a damp sponge eraser.

**MAXIMUM WEIGHT: 0 LBS (0 KG)**  
**PESO MÁXIMO: 0 LIBRAS (0 KILOGRAMO)**  
**POIDS MAXIMUM: 0 LIVRES (0 KILOGRAMME)**

**MAXIMUM WEIGHT: 50 LBS (22.68 KG)**  
**PESO MÁXIMO: 50 LIBRAS (22.68 KILOGRAMO)**  
**POIDS MAXIMUM: 50 LIVRES (22.68 KILOGRAMME)**

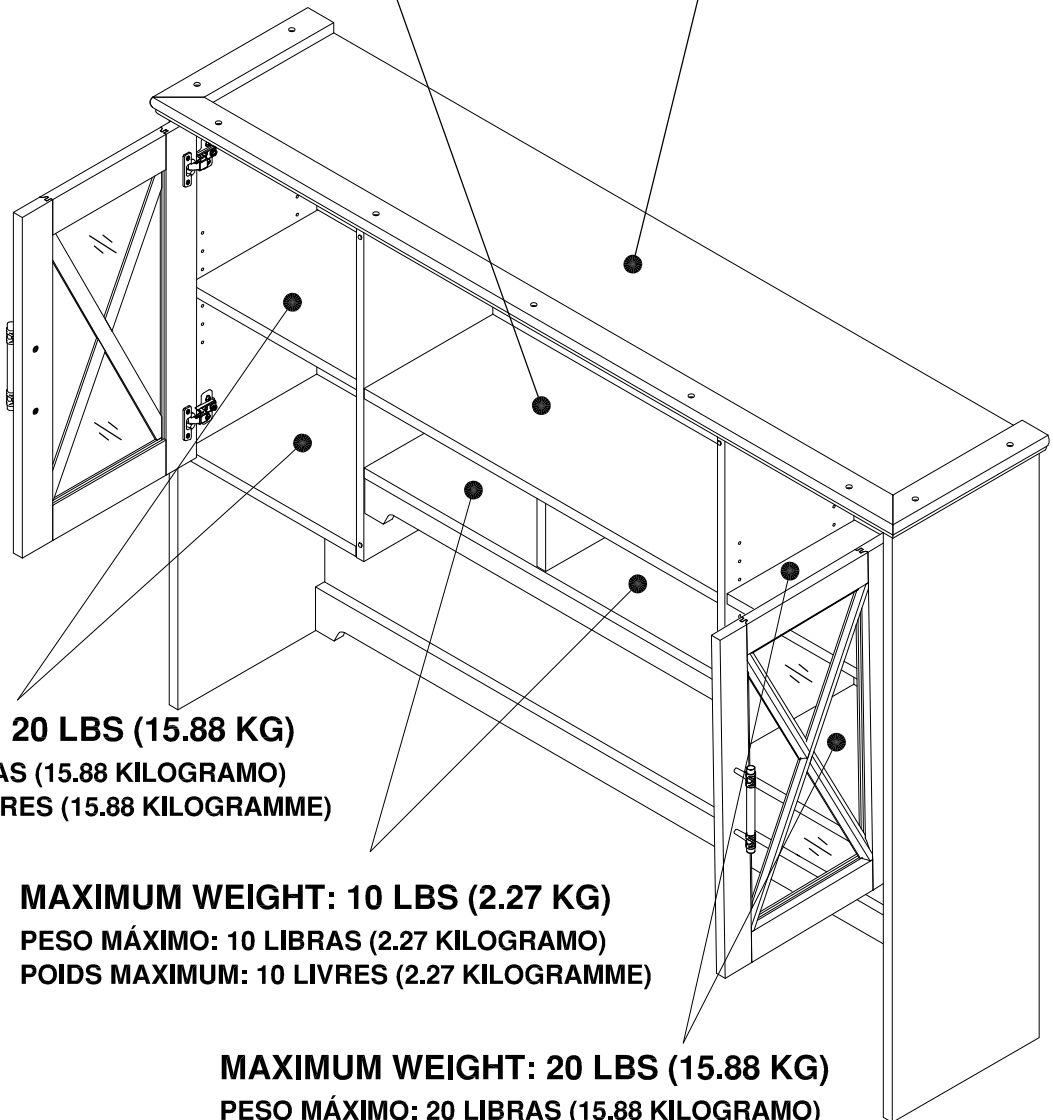

**MAXIMUM WEIGHT: 20 LBS (15.88 KG)**  
**PESO MÁXIMO: 20 LIBRAS (15.88 KILOGRAMO)**  
**POIDS MAXIMUM: 20 LIVRES (15.88 KILOGRAMME)**

**MAXIMUM WEIGHT: 10 LBS (2.27 KG)**  
**PESO MÁXIMO: 10 LIBRAS (2.27 KILOGRAMO)**  
**POIDS MAXIMUM: 10 LIVRES (2.27 KILOGRAMME)**

**MAXIMUM WEIGHT: 20 LBS (15.88 KG)**  
**PESO MÁXIMO: 20 LIBRAS (15.88 KILOGRAMO)**  
**POIDS MAXIMUM: 20 LIVRES (15.88 KILOGRAMME)**

Congratulations! You are all done. If you have any questions or concerns, please call.

# PARTS LIST

A	[1]	S211123	J	[2]	S211131
B	[1]	W211124	K	[1]	W211132
C	[1]	W211125	L	[1]	W211133
D	[1]	W211126	M	[1]	W211134
E	[1]	W211127	N	[1]	W211135
F	[1]	W211128	O	[1]	W211136
G	[1]	W211129	P	[2]	W211137
H	[1]	W211130	Q	[2]	W211138

# WARRANTY INFORMATION/INFORMATIONS POUR LA GARANTIE/INFORMACIÓN DE GARANTÍA

## WRITTEN WARRANTY TO YOU

In order to provide you with timely assistance, please thoroughly inspect your furniture for missing or defective parts immediately after opening the carton. To receive replacement or missing parts under this warranty, call our Consumer Service Department. Please have the Model, Part, and Lot Numbers found in the instruction manual available for your reference. You will also need your sales receipt or other proof of purchase. Replacement part(s) will be shipped to you at no charge with assuming all shipping and handling charges.

This product is warranted to the original purchaser at the time of purchase and for a period of one year thereafter.

We warrant to you, the original purchaser, that our furniture and all its parts and components are free of defects in material or workmanship. "Defects," as used in this warranty, is defined as any imperfection which impairs the use of the furniture product.

Our warranty is expressly limited to the replacement of furniture parts and components. For one year after the date of purchase, we will replace any parts that are defective in material or workmanship.

This warranty applies under conditions of normal use. Our products are not intended for outdoor use. This warranty does not cover: 1) defects caused by improper assembly or disassembly; 2) defects occurring after purchase due to product modification, intentional damage, accident, misuse, abuse, negligence or exposure to the elements; and 3) labor or assembly costs. 4) batteries are not included.

IMPLIED WARRANTIES, INCLUDING THE WARRANTY OF MERCHANTABILITY, SHALL NOT EXTEND BEYOND THE DURATION OF THE WRITTEN WARRANTY STATED ABOVE, AND IN NO EVENT SHALL BE LIABLE FOR INCIDENTAL OR CONSEQUENTIAL DAMAGES RESULTING FROM USE OF THE PRODUCT. Some states do not allow a limitation on how long an implied warranty lasts or the exclusion or limitation of incidental or consequential damages, so the above limitation and exclusion may not apply to you.

This warranty gives you specific legal rights. You may also have other rights that may vary from state to state.

## VOTRE GARANTIE

Afin de vous assister rapidement, veuillez inspecter votre mobilier en détail immédiatement après l'ouverture du carton en cas de pièces manquantes ou défectueuses. Pour recevoir une pièce de rechange ou manquante couverte par cette garantie, appelez notre département de service clientèle GRATUITEMENT. Veuillez tenir à disposition les numéros de modèle, de pièce et de lot qui se trouvent dans le manuel d'instruction pour votre référence. Vous aurez également besoin de votre reçu ou d'une autre preuve d'achat. La (les) pièce(s) de rechange vous sera (seront) envoyée(s) sans frais, se chargeant de tous les frais d'expédition.

Tout le produit est garanti à l'acheteur original à partir de la date d'achat pour une période d'un an.

Nous vous garantissons, à vous l'acheteur original, que notre mobilier et toutes ses pièces et composants sont sans défaut de matériau ou de fabrication. Le terme "défauts" utilisé dans cette garantie, est défini comme étant toutes les imperfections qui compromettent l'utilisation du meuble.

Notre garantie est expressément limitée au remplacement des pièces et des composants du mobilier. Pendant un an après la date d'achat, remplacera toute pièce défectueuse dans le matériau ou sa fabrication.

Cette garantie d'applique sous des conditions d'utilisation normale. Nos produits ne sont pas destinés à être utilisés en plein air. Cette garantie ne couvre pas: 1) les défauts causés par un mauvais assemblage ou démontage, 2) les défauts ayant lieu après l'achat et dus à la modification du produit, des dommages intentionnels, des accidents, une mauvaise utilisation, un mauvais traitement, la négligence ou l'exposition aux éléments, et 3) les frais de main d'œuvre ou d'assemblage. 4) les piles ne sont pas incluses.

LES GARANTIES TACITES, Y COMPRIS LA GARANTIE DE QUALITE MARCHANDE, NE S'ETENDRONT PAS AU-DELA DE LA DUREE ECRITE CITEE CI-DESSUS, ET NE SERA EN AUCUN CAS RESPONSABLE DES DOMMAGES ACCESSOIRES OU INDIRECTS RESULTANT DE L'UTILISATION DU PRODUIT. Certains états ne permettent pas d'appliquer une limite à la durée de la garantie tacite, ni une exclusion ou limitation des dommages accessoires ou indirects; dans ce cas les limitations ou exclusion ci-dessus peuvent ne pas s'appliquer à vous.

Cette garantie vous donne des droits légaux spécifiques. Il se peut que vous ayez également d'autres droits qui peuvent varier d'un état à l'autre.

## GARANTIA ESCRITA DE PARA USTED

Para brindarle asistencia oportuna, por favor, verifique detalladamente que a su mueble no le falte o tenga piezas defectuosas inmediatamente después de abrir la caja. Para recibir un reemplazo o la parte faltante bajo esta garantía, llame a nuestro Departamento de Servicio al Consumidor GRATIS. Sírvase traer los números de modelo, parte y lote que se encuentran en el manual de instrucciones disponible para su referencia. Además, necesitará el recibo de su compra u otra prueba de compra. La(s) pieza(s) de reemplazo será(n) enviada(s) sin recargo por asumiendo los gastos de envío y manipuleo.

Todo mueble es garantizado al comprador original al momento de la compra y por un periodo de uno año en adelante.

Le garantizamos a usted, el comprador original, que nuestros muebles sus partes y componentes están libres de defectos en materiales o trabajo. "Defectos", según se usa en esta garantía, se define como una imperfección que perjudica el uso del producto mobiliario.

Nuestra garantía se limita expresamente al reemplazo de partes y componentes mobiliarios. Durante uno año después de la fecha de compra, reemplazará cualquier parte defectuosa en material o trabajo.

Esta garantía se aplica bajo condiciones de uso normal. Nuestros productos de no son para uso en exteriores. Esta garantía no cubre: 1) defectos causados por un ensamblaje

o desensamblaje inadecuado; 2) defectos que ocurran después de la compra debido a modificación del producto, daño intencional, accidente, mal uso, abuso, negligencia o exposición a los elementos; y 3) costos de trabajo o ensamblaje. 4) las baterías no están incluidas.

LAS GARANTÍAS IMPLICADAS, INCLUYENDO LA GARANTÍA DE COMERCIABILIDAD, NO SE EXTENDERÁN MÁS ALLÁ DE LA DURACIÓN DE LA GARANTÍA ESCRITA MENCIONADA, Y EN NINGÚN CASO SERÁ RESPONSABLE POR DAÑOS INCIDENTALES O CONSIGUIENTES COMO RESULTADO DEL USO DEL PRODUCTO. Algunos estados no permiten una limitación sobre el tiempo de duración de la garantía implicada o la exclusión o limitación de daños incidentales o consiguientes, de manera que la limitación y exclusión mencionadas pueden no aplicarse para usted.

Esta garantía le otorga derechos legales específicos. Puede también tener otros derechos que pueden variar según los estados.