

**B1 & B2
QUEEN SIZE BED**

ASSEMBLY INSTRUCTIONS



ASSEMBLY INSTRUCTIONS

ASSEMBLY TIPS:

- 1 . Remove hardware from box and sort by size.
- 2 . Please check to see that all hardware and parts are present prior to start of assembly.
- 3 . Please follow attached instructions in the same sequence as numbered to assure fast & easy assembly.



Warning !

- 1 . Don't attempt to repair or modify parts that are broken or defective. Please contact the store immediately.
- 2 . This product is for home use only and not intended for commercial establishment.



ASSEMBLY TIME	20 MINUTES
---------------	------------

PARTS IDENTIFICATION

B1 (BOX 1)

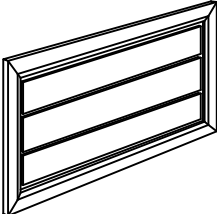
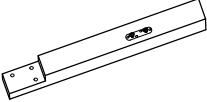
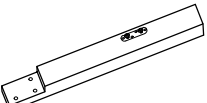
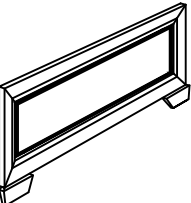
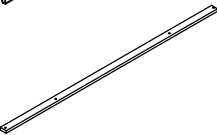
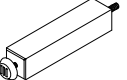
A		HEADBOARD PANEL	1PC
B		RIGHT HEADBOARD LEG	1PC
C		LEFT HEADBOARD LEG	1PC
D		FOOTBOARD	1PC
E		BED SLAT	4PCS
F		BED SLAT SUPPORT WITH LEVELER	4PCS

B2 (BOX 2)

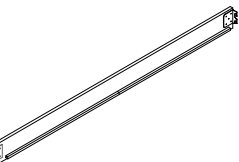
G		BED RAIL	2PCS
----------	---	----------	------

HB

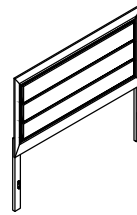

(B1) HEADBOARD COMPLETE *FROM BOX 1 1PC



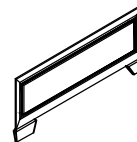



D



(B1) FOOTBOARD *FROM BOX 1 1PC

HARDWARE IDENTIFICATION

Z - B1 (BOX 1) - HARDWARE PACK IS LOCATED IN (B1)

1		BOLT	6PCS
2		LOCK WASHER	6PCS
3		FLAT WASHER	6PCS
4		FLAT HEAD SCREW	8PCS
5		SMALL ALLEN WRENCH	1PC
6		BIG ALLEN WRENCH	1PC

NOTE : PHILLIPS HEAD SCREW DRIVER IS REQUIRED IN THE ASSEMBLY PROCESS; HOWEVER MANUFACTURER DOES NOT PROVIDE THIS ITEM.

ASSEMBLY INSTRUCTIONS

BOX 1

STEP 1

Please take note the marking on the leg and headboard

"L" Marking behind the Headboard & Leg

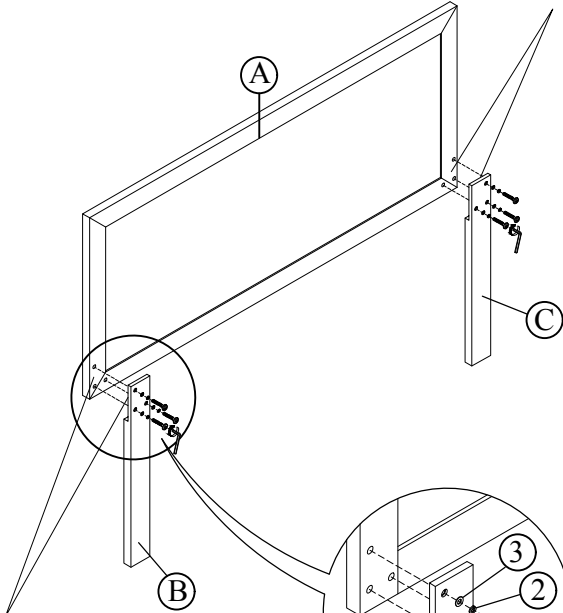

"R" Marking behind the Headboard & Leg

BOX 1 & BOX 2

STEP 2

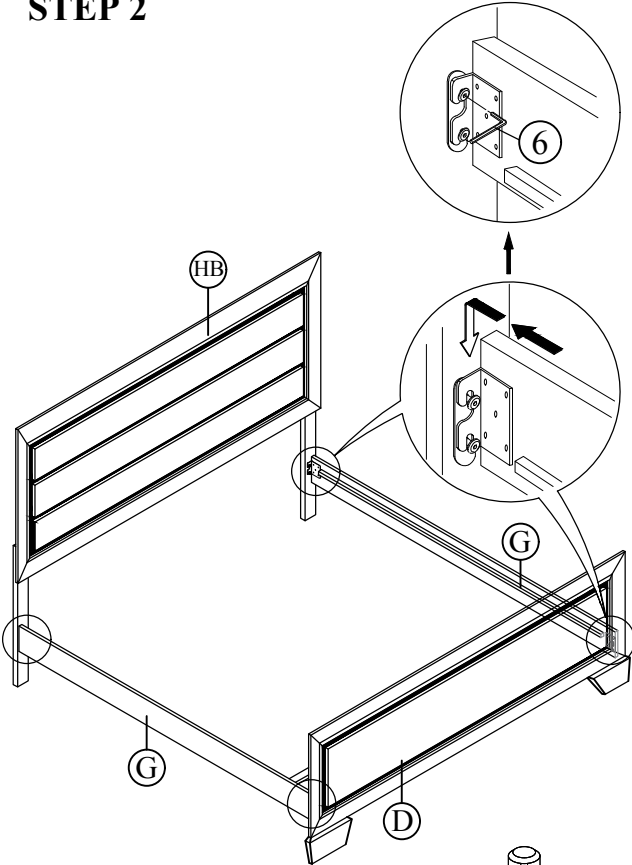

STEP 3

