

ASSEMBLY INSTRUCTIONS

ASSEMBLY INSTRUCTIONS

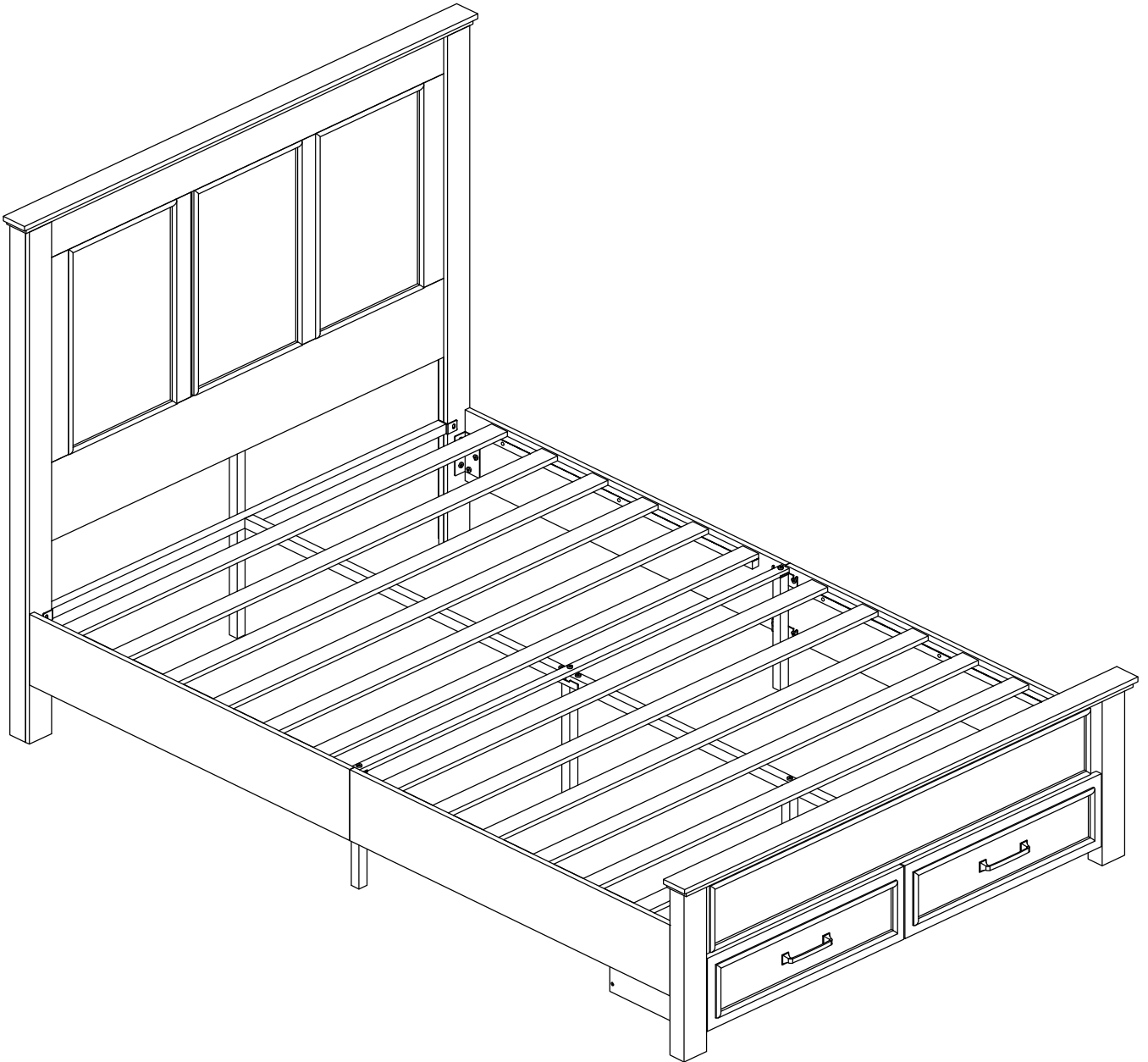

Dear Customers,
Thank you for purchasing our product. Please read this instruction manual carefully after receiving this product. It will help you assemble this product quickly, safely and correctly. You can keep this manual for future reference.
MADE IN CHINA

ASSEMBLY INSTRUCTIONS



Please follow the instruction manuals and use a pad to protect the product during your assembly.

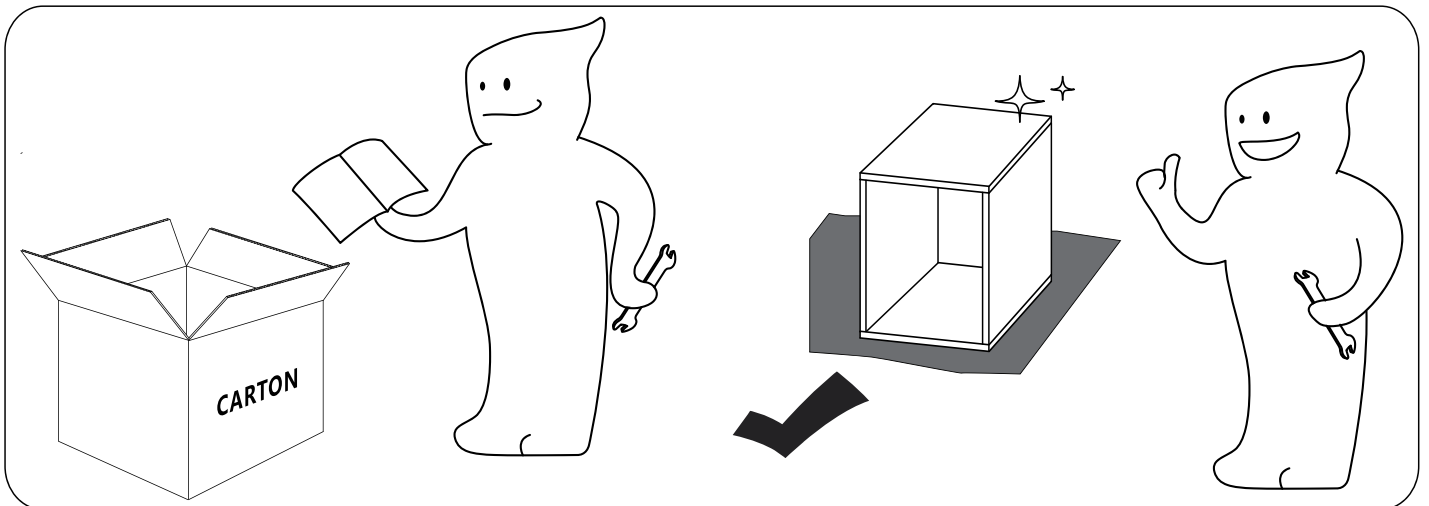
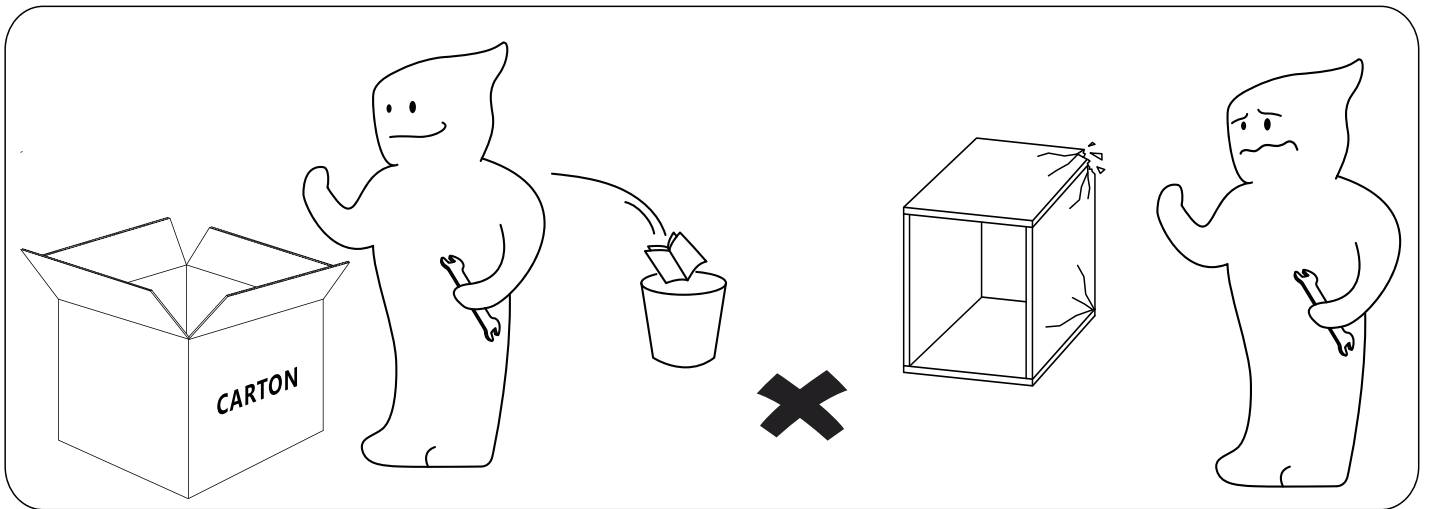

Note:

1. Should be assembled on flat ground to keep balance.
2. Before completing the installation, do not tighten the screws.

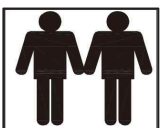





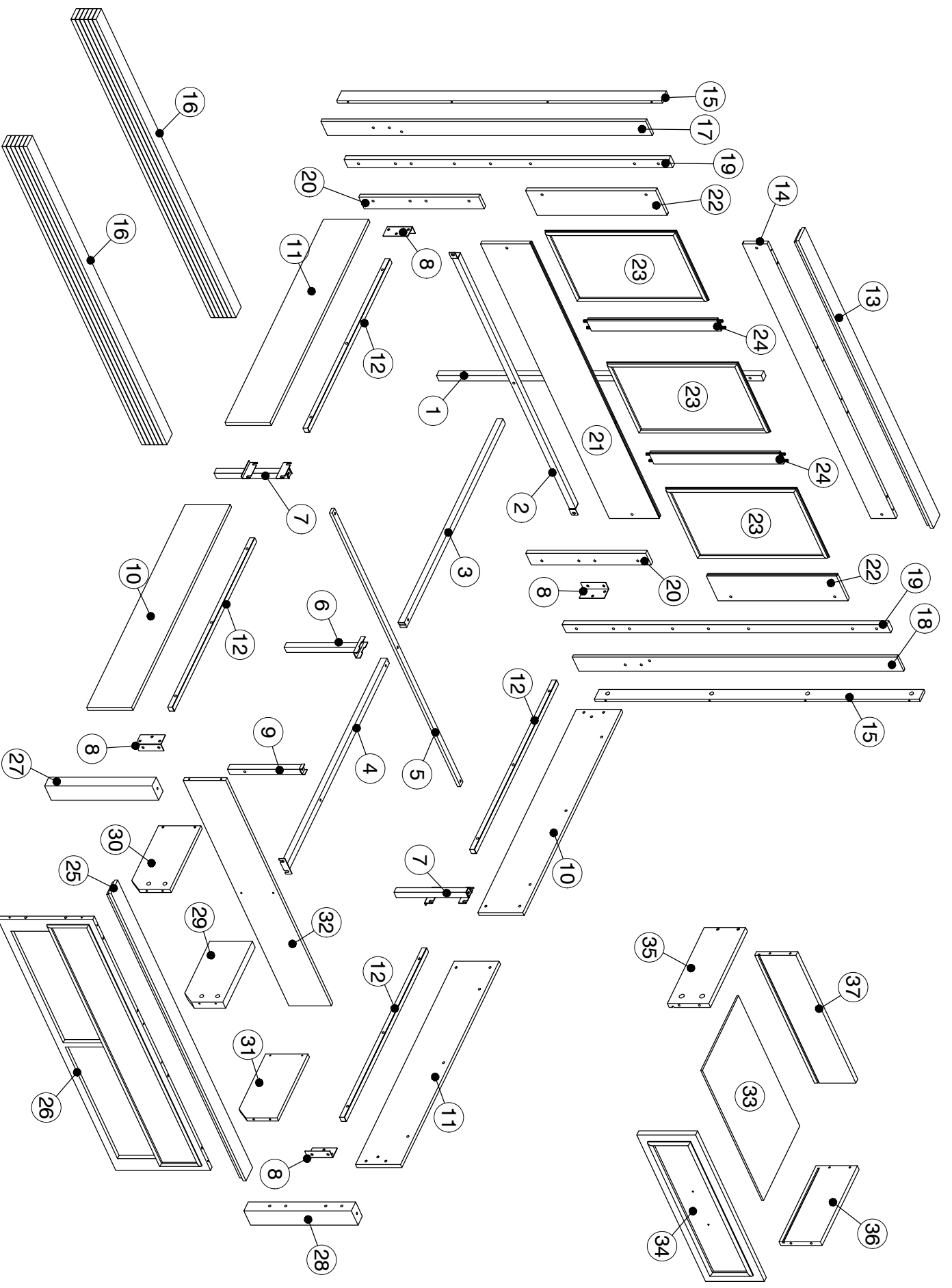

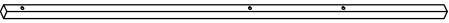
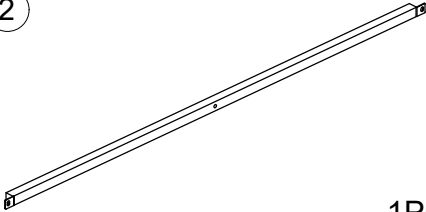
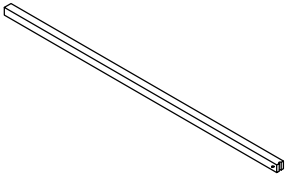
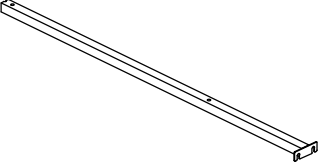
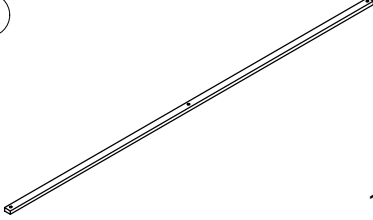
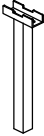

For easier and better assembly, **2** or more adults are required.

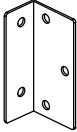

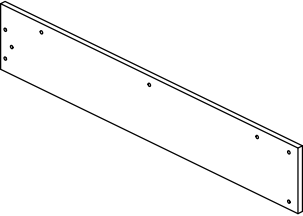
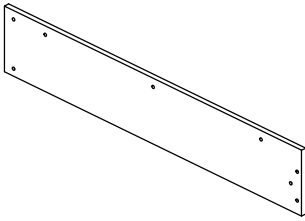
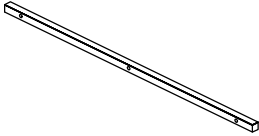
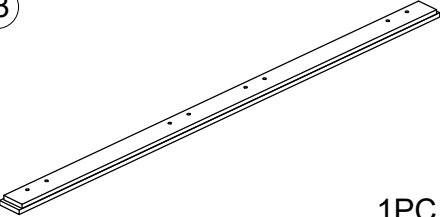
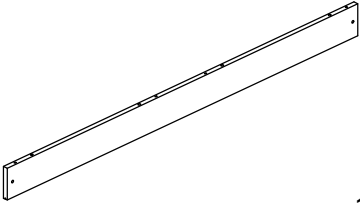
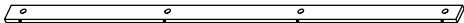
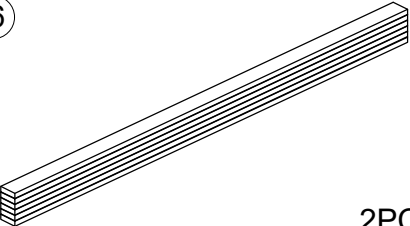
ASSEMBLY INSTRUCTIONS

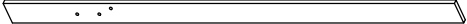
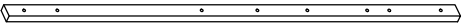
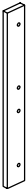
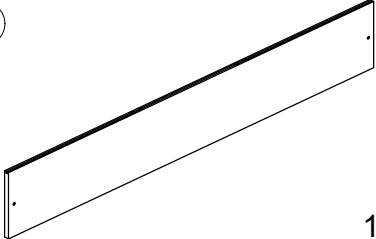
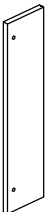
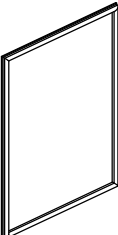





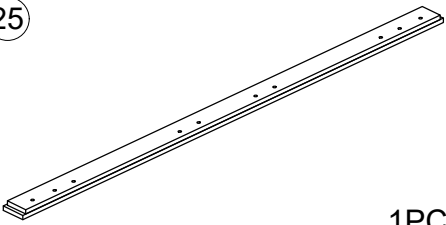
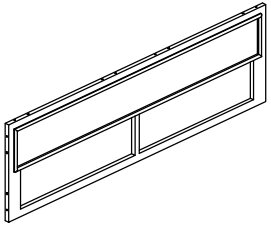

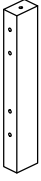
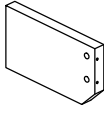
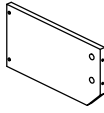
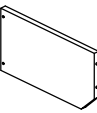
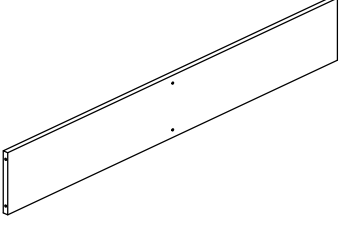
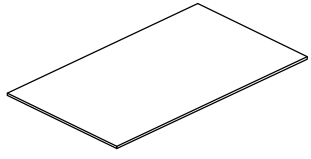
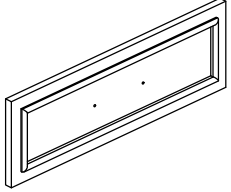
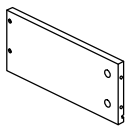
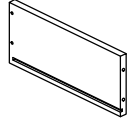
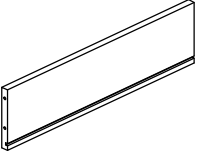

ASSEMBLY INSTRUCTIONS

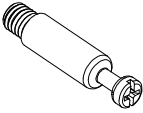
<p>①</p>  <p>1PC</p>	<p>②</p>  <p>1PC</p>	<p>③</p>  <p>1PC</p>
<p>④</p>  <p>1PC</p>	<p>⑤</p>  <p>1PC</p>	<p>⑥</p>  <p>1PC</p>
<p>⑦</p>  <p>2PCS</p>	<p>⑧</p>  <p>4PCS</p>	<p>⑨</p>  <p>1PC</p>
<p>⑩</p>  <p>2PCS</p>	<p>⑪</p>  <p>2PCS</p>	<p>⑫</p>  <p>4PCS</p>
<p>⑬</p>  <p>1PC</p>	<p>⑭</p>  <p>1PC</p>	<p>⑮</p>  <p>2PCS</p>
<p>⑯</p>  <p>2PCS</p>	<p>⑰</p>  <p>1PC</p>	<p>⑱</p>  <p>1PC</p>
<p>⑲</p>  <p>2PCS</p>	<p>⑳</p>  <p>2PCS</p>	<p>㉑</p>  <p>1PC</p>
<p>㉒</p>  <p>2PCS</p>	<p>㉓</p>  <p>3PCS</p>	<p>㉔</p>  <p>2PCS</p>

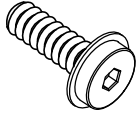
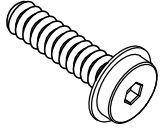
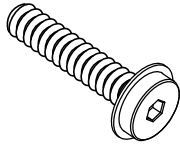
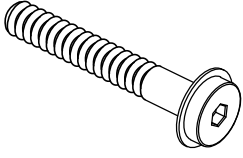
ASSEMBLY INSTRUCTIONS

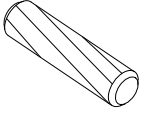
<p>25</p>  <p>1PC</p>	<p>26</p>  <p>1PC</p>	<p>27</p>  <p>1PC</p>
<p>28</p>  <p>1PC</p>	<p>29</p>  <p>1PC</p>	<p>30</p>  <p>1PC</p>
<p>31</p>  <p>1PC</p>	<p>32</p>  <p>1PC</p>	<p>33</p>  <p>2PCS</p>
<p>34</p>  <p>2PCS</p>	<p>35</p>  <p>2PCS</p>	<p>36</p>  <p>2PCS</p>
<p>37</p>  <p>2PCS</p>		

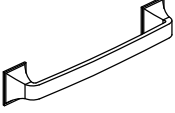
ASSEMBLY INSTRUCTIONS

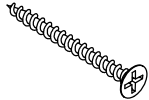
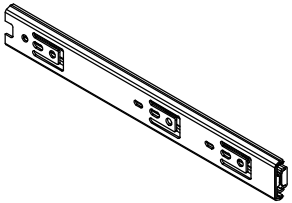
<p>A</p>  <p>34PCS+1PC</p>	<p>B</p>  <p>34PCS+1PC</p>	<p>C</p>  <p>M8*12mm 28PCS+1PC</p>
<p>D</p>  <p>M8*35mm 3PCS</p>	<p>E</p>  <p>M8*30mm 14PCS+1PC</p>	<p>F</p>  <p>M8*45mm 20PCS+1PC</p>
<p>G</p>  <p>M8*65mm 1PC</p>	<p>H</p>  <p>M5 1PC</p>	<p>I</p>  <p>Ø6*30mm 22PCS+1PC</p>
<p>J</p>  <p>4PCS</p>	<p>K</p>  <p>2PCS</p>	<p>L</p>  <p>Ø3.5*15mm 24PCS+1PC</p>
<p>M</p>  <p>Ø4*30mm 14PCS+1PC</p>	<p>N</p>  <p>4PCS</p>	

ASSEMBLY INSTRUCTIONS

1

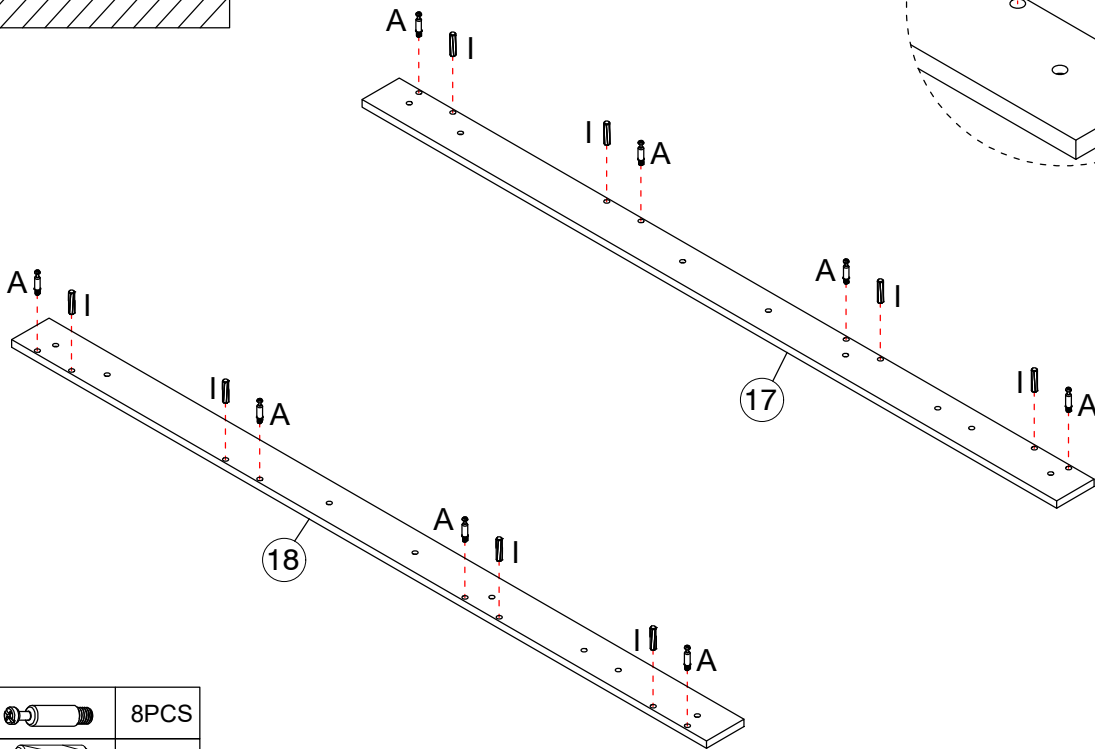
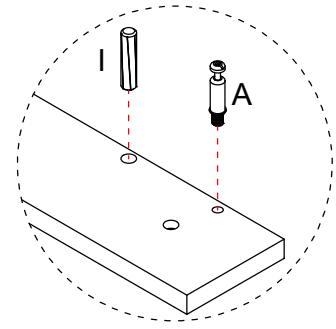
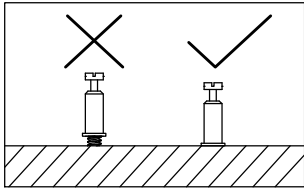

A		8PCS
I		8PCS

2

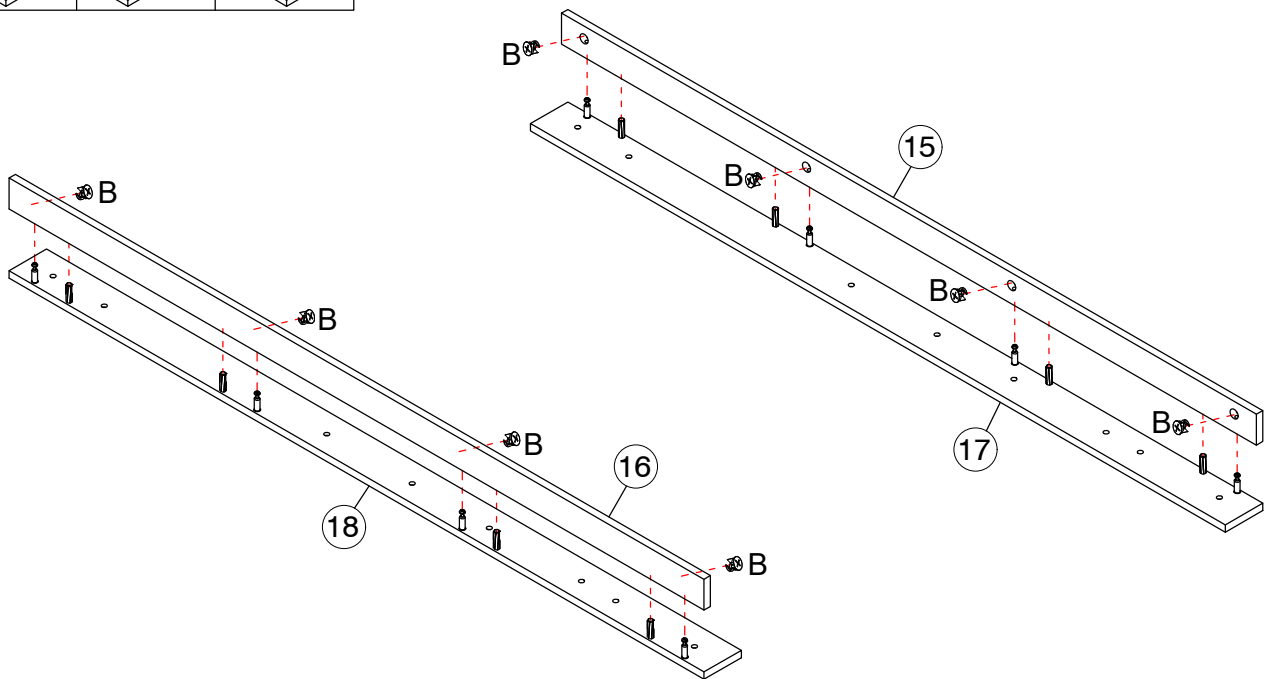
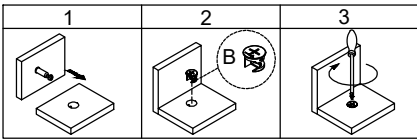

B		8PCS
---	--	------

ASSEMBLY INSTRUCTIONS

3

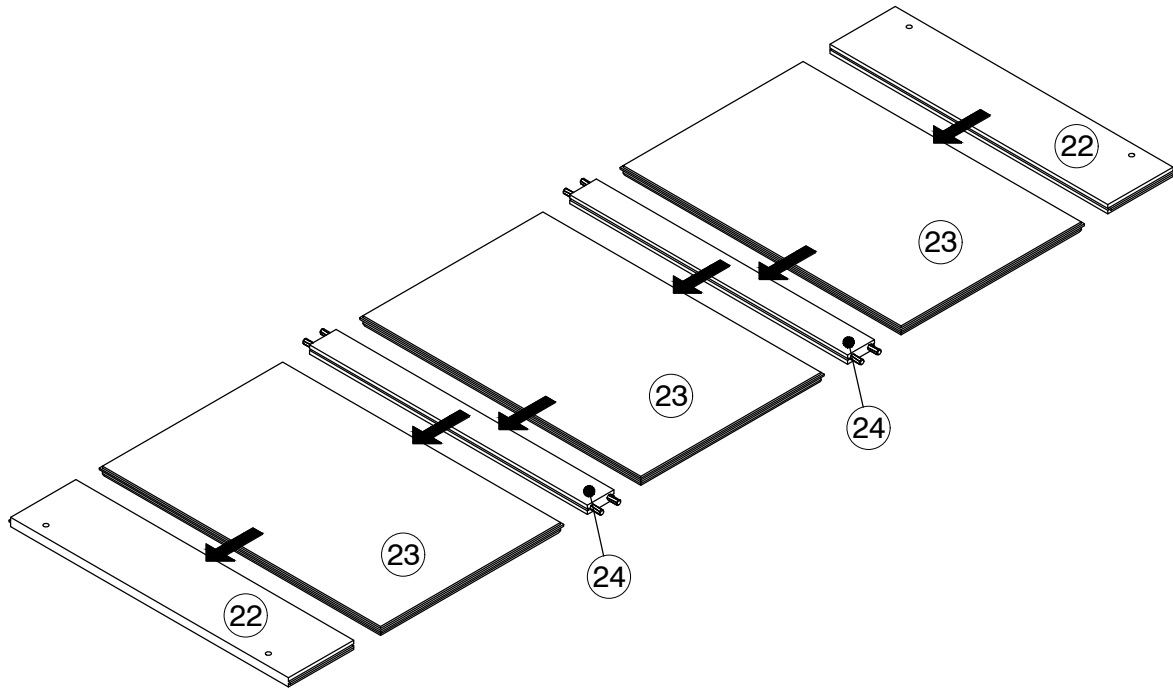

4

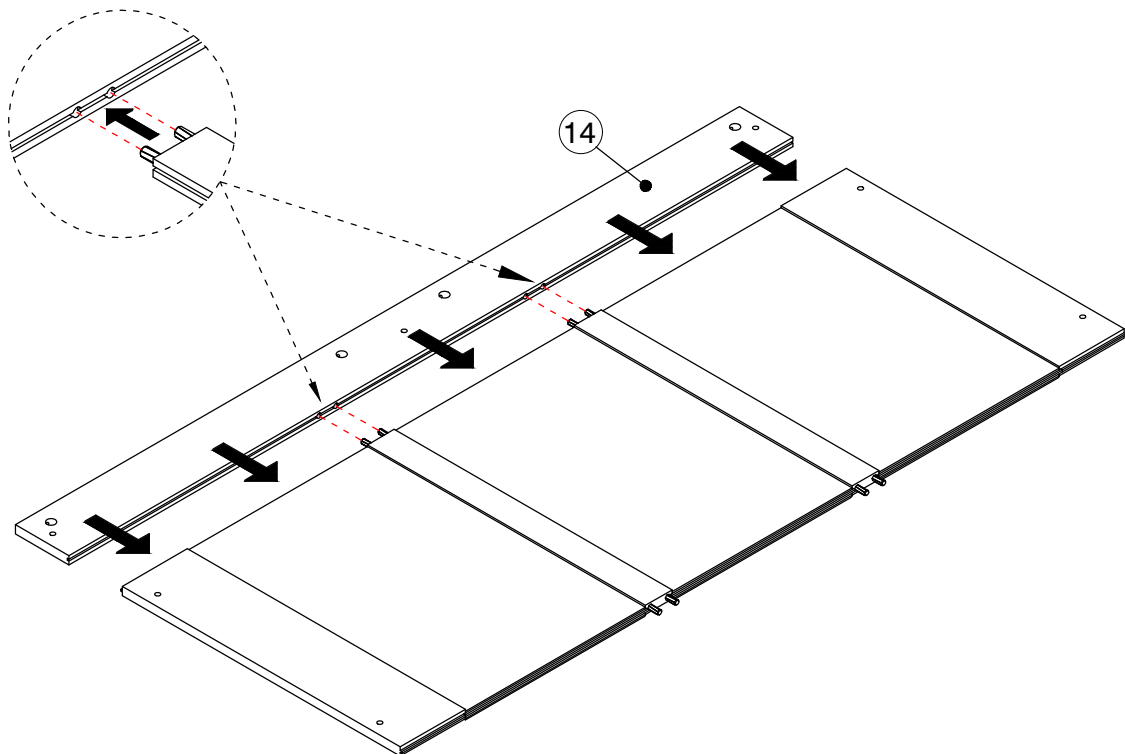

ASSEMBLY INSTRUCTIONS

5

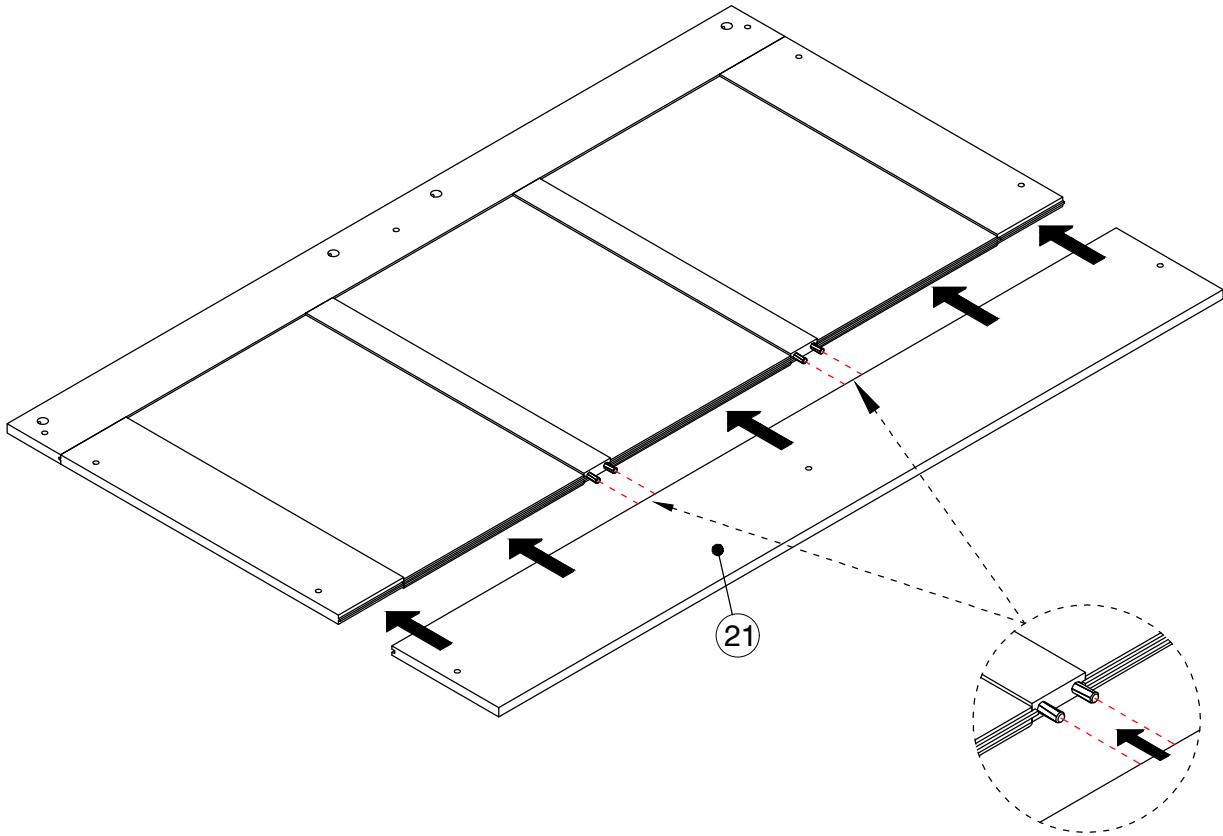

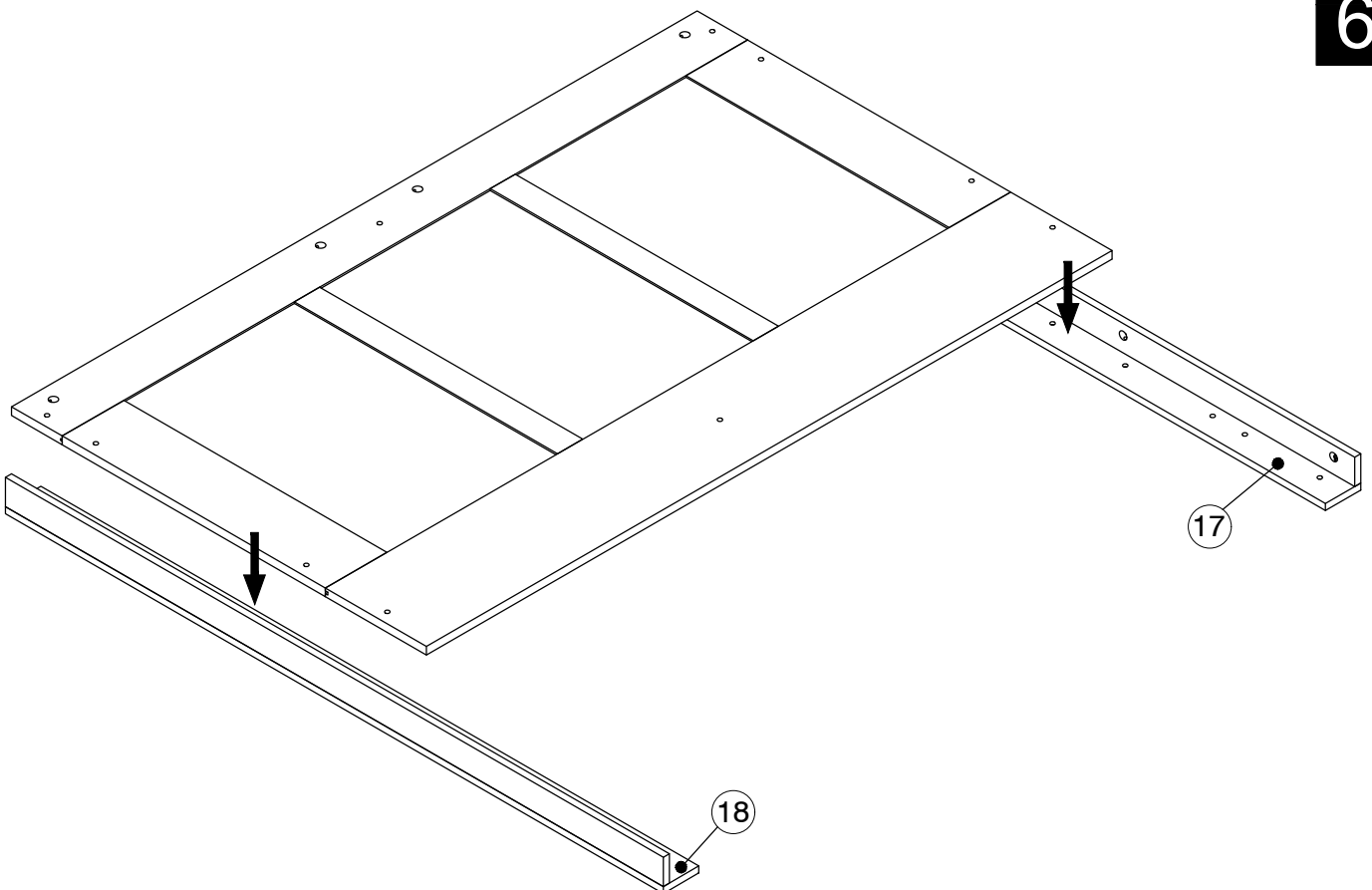

6



ASSEMBLY INSTRUCTIONS

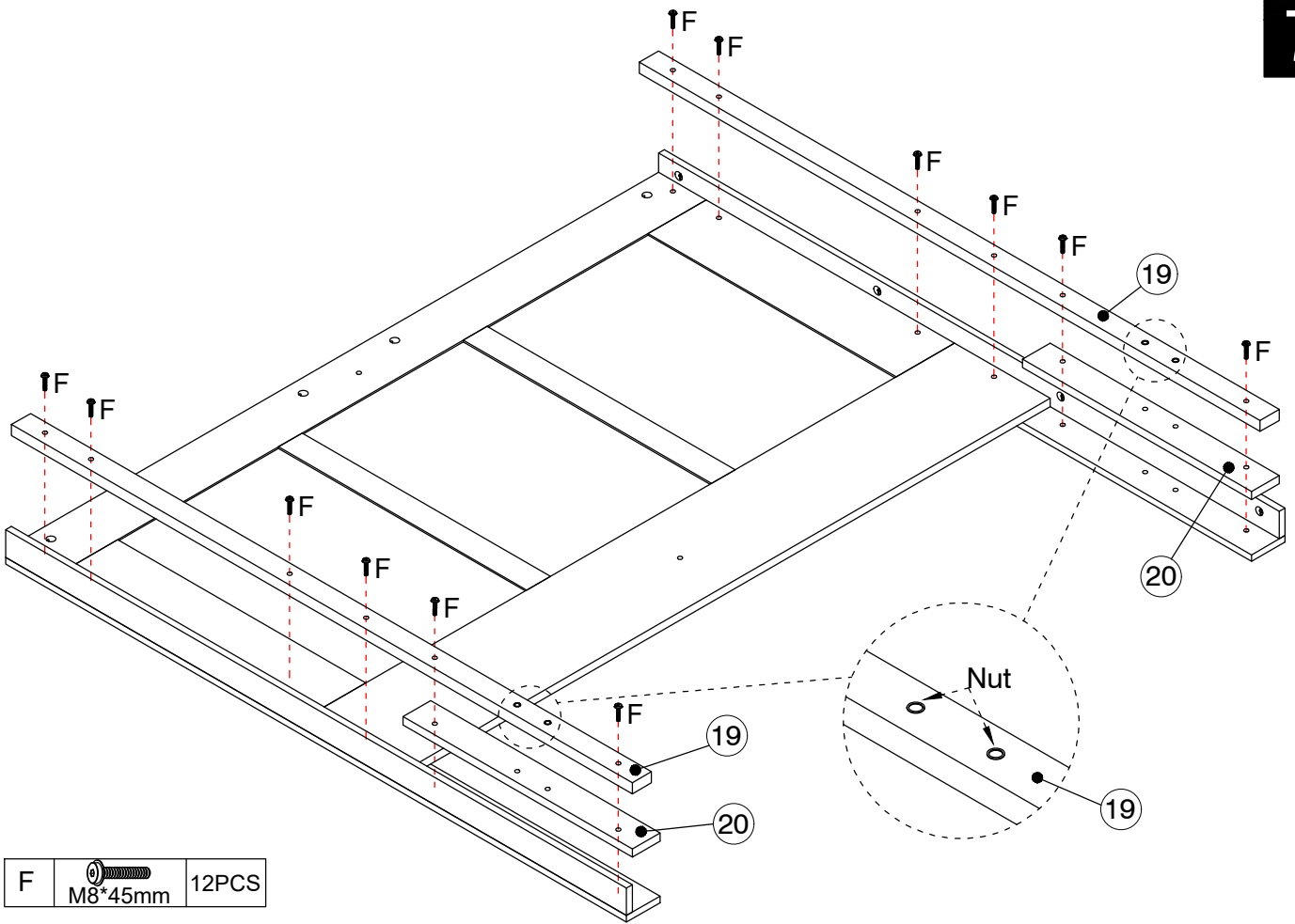

7

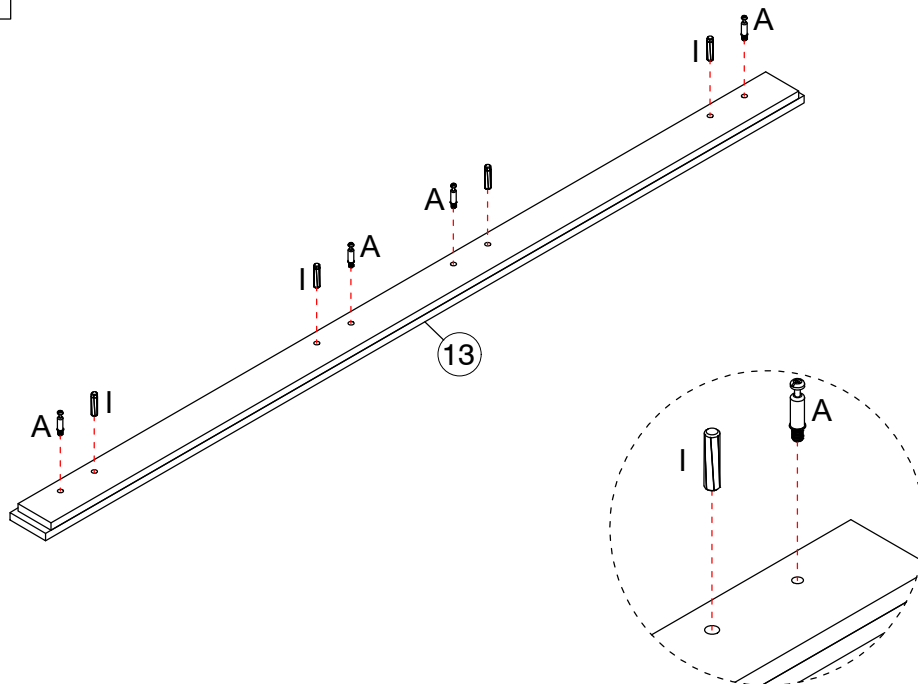
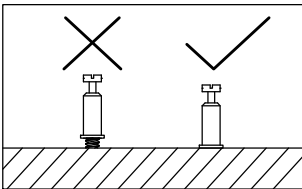

F		12PCS
	M8*45mm	

8



A		4PCS
I		4PCS
	Ø6*30mm	

ASSEMBLY INSTRUCTIONS

9

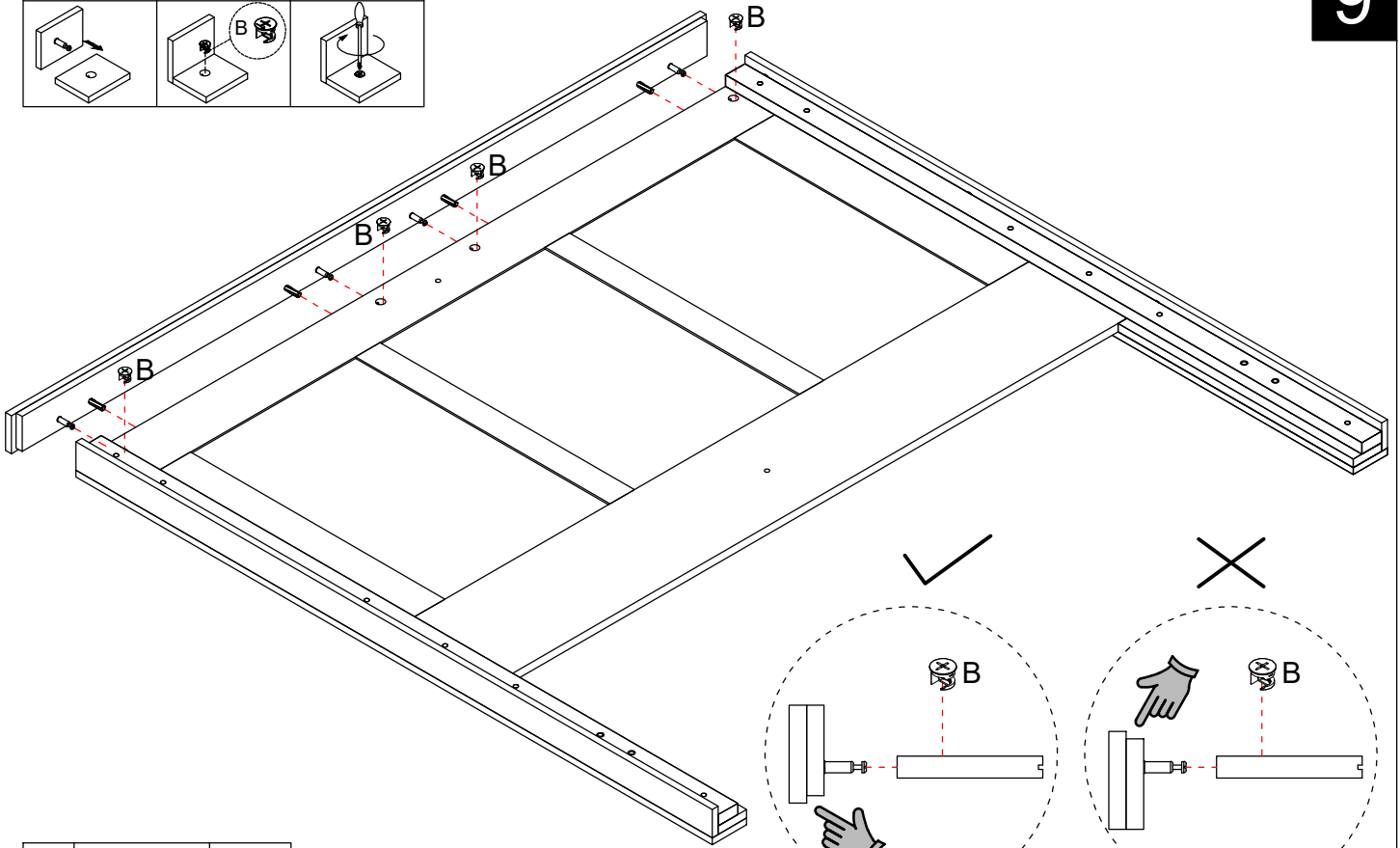
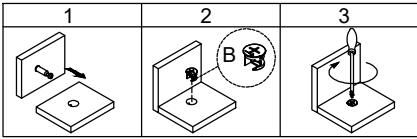

10

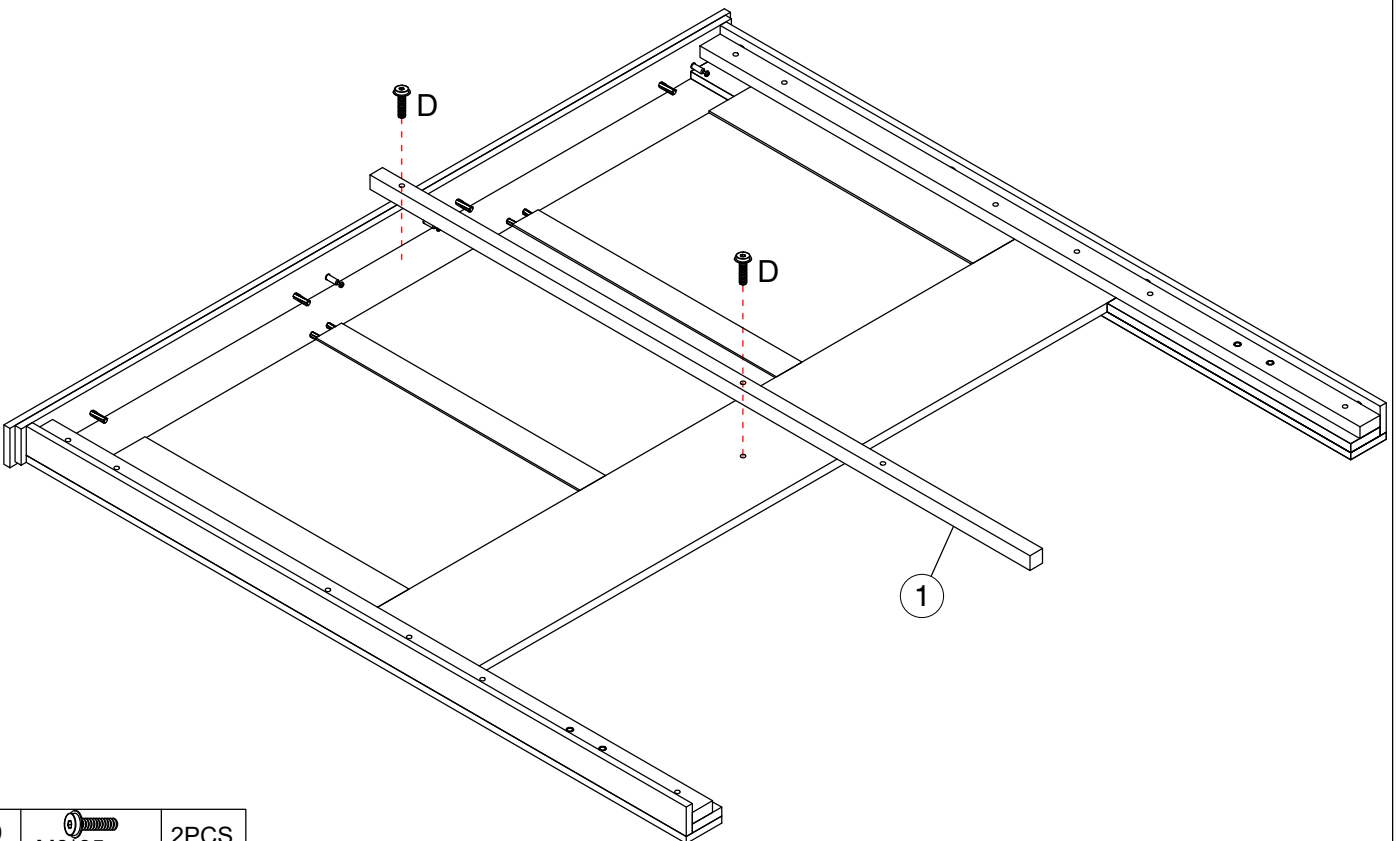

ASSEMBLY INSTRUCTIONS

11

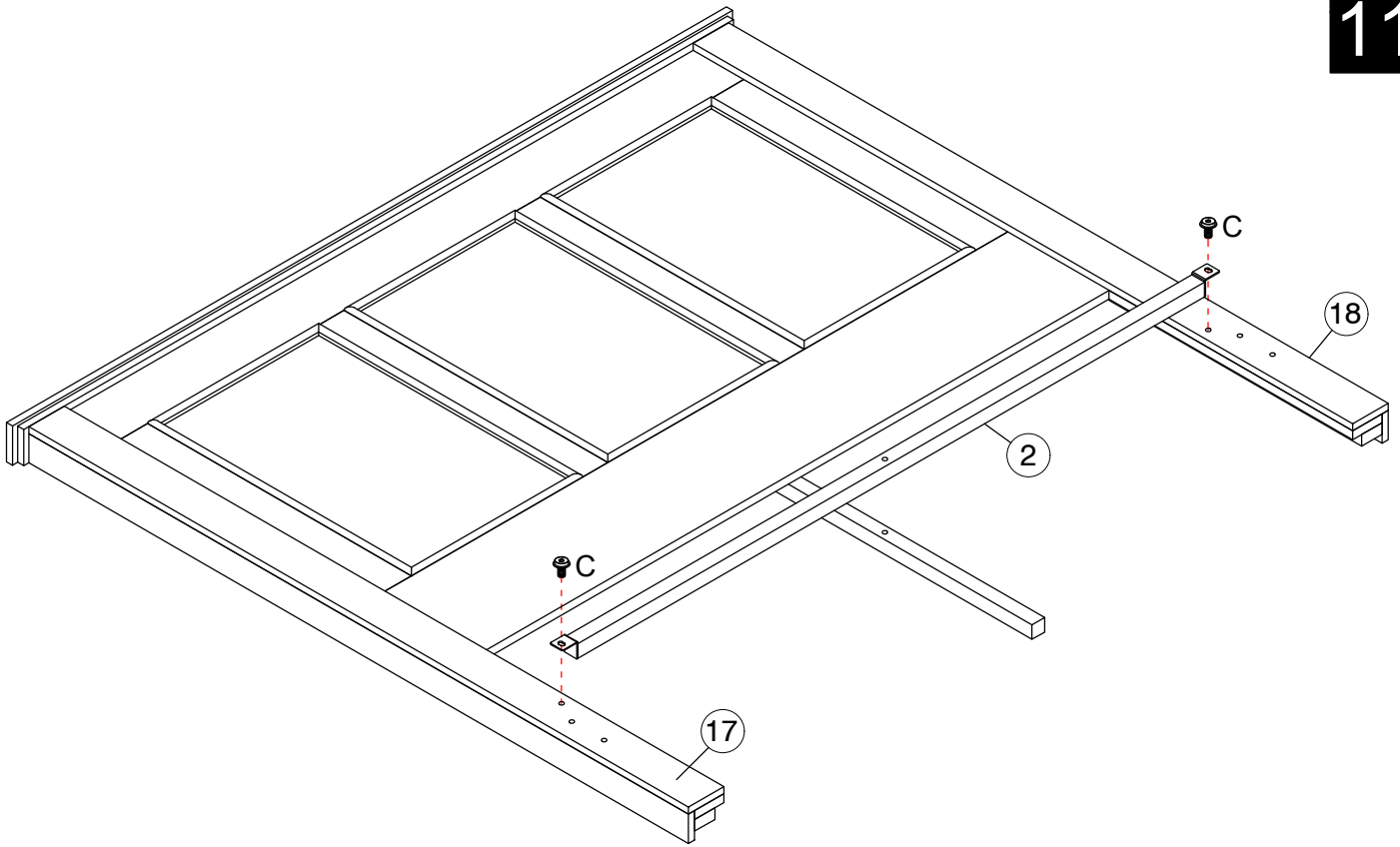

C	 M8*12mm	2PCS
---	---	------

12

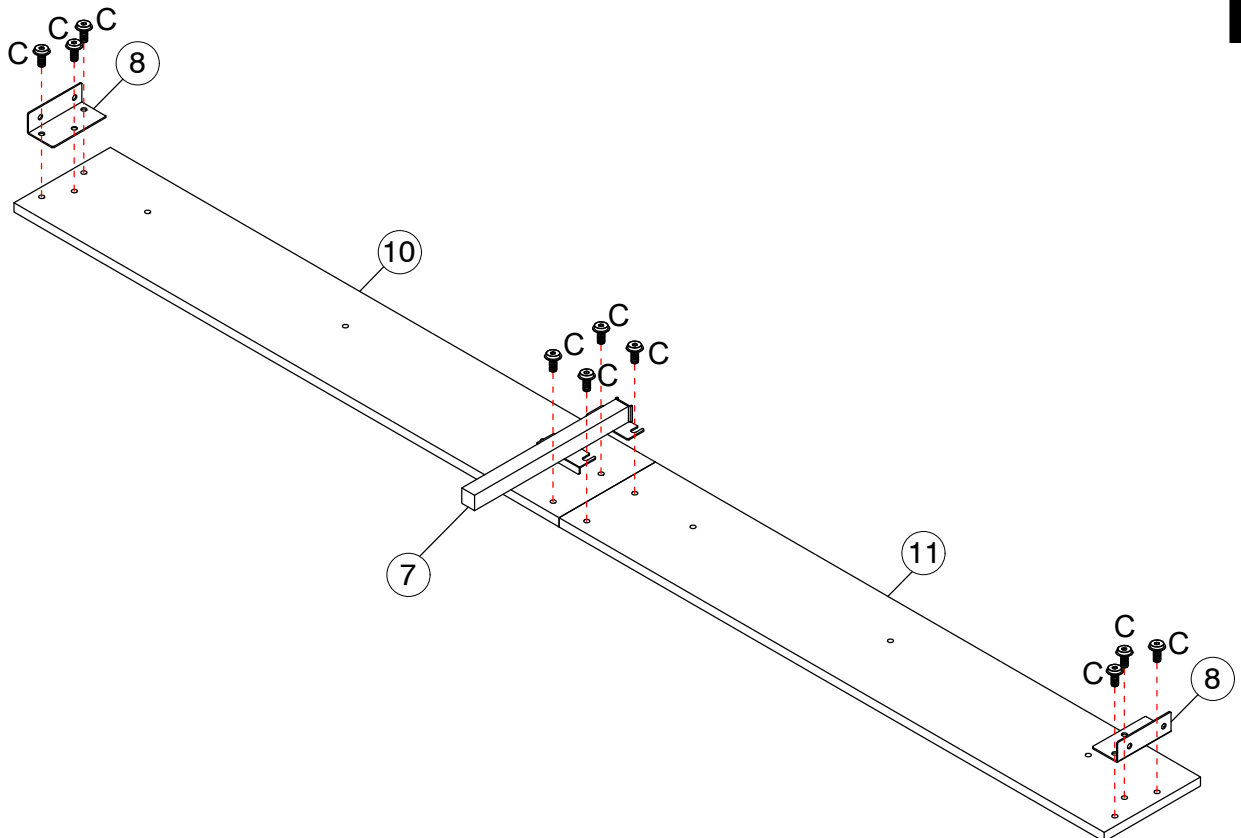



C	 M8*12mm	20PCS
---	---	-------

x2

ASSEMBLY INSTRUCTIONS

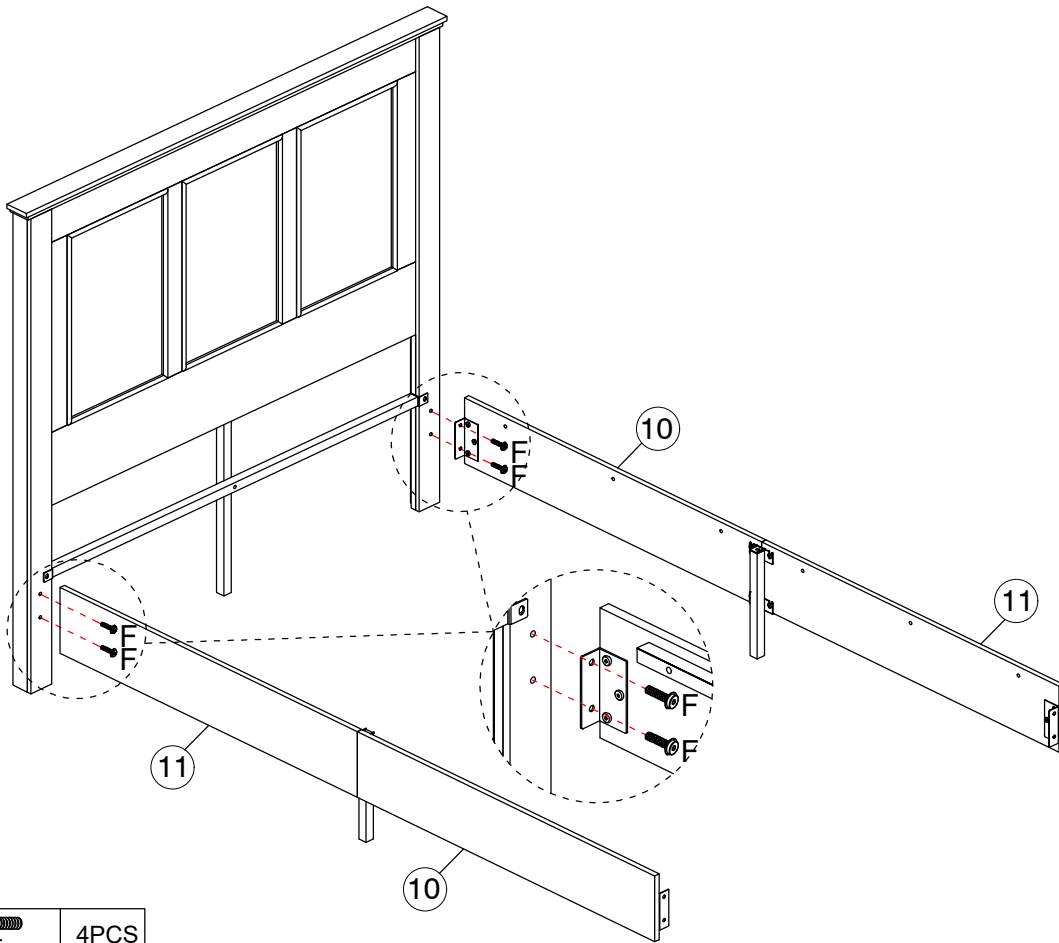
13



F  M8*45mm 4PCS

x2

14

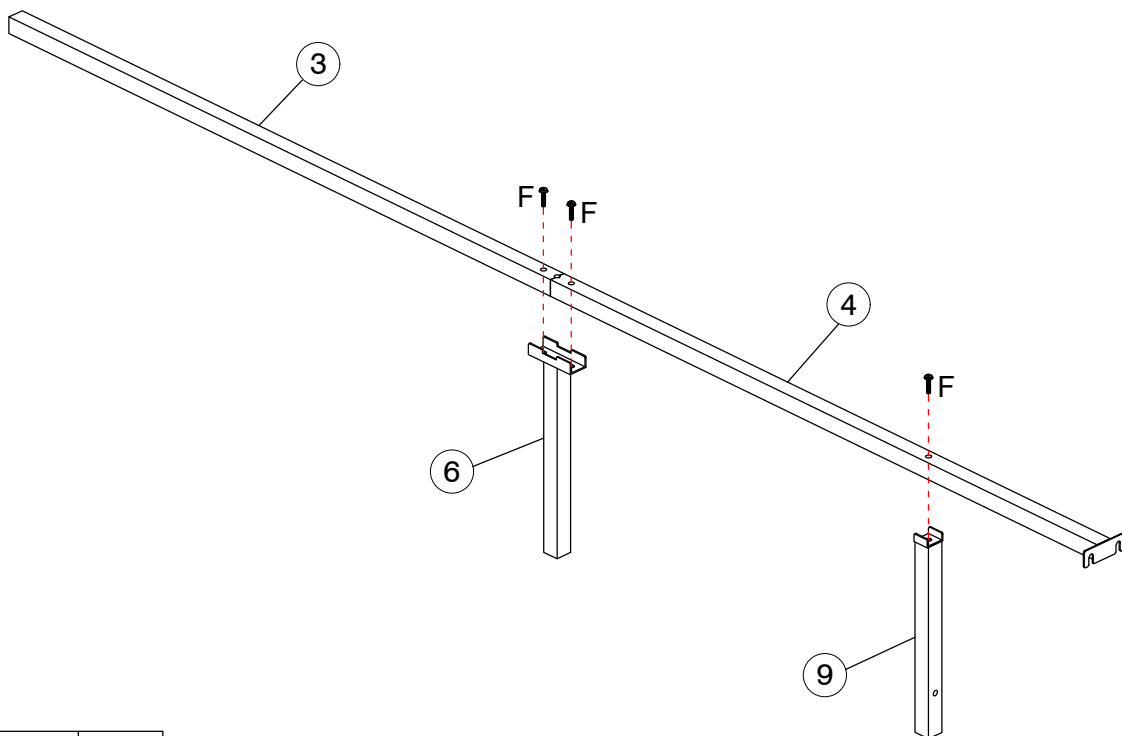

F  M8*45mm 3PCS

ASSEMBLY INSTRUCTIONS

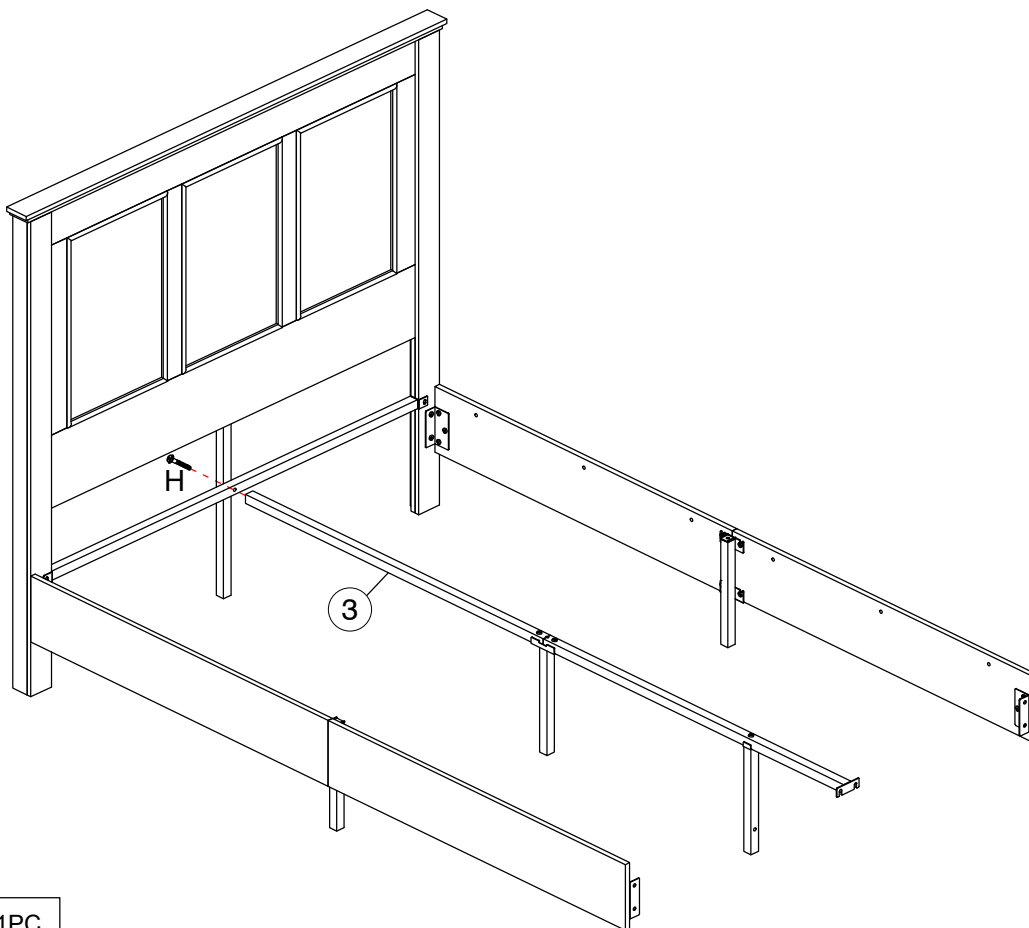

15

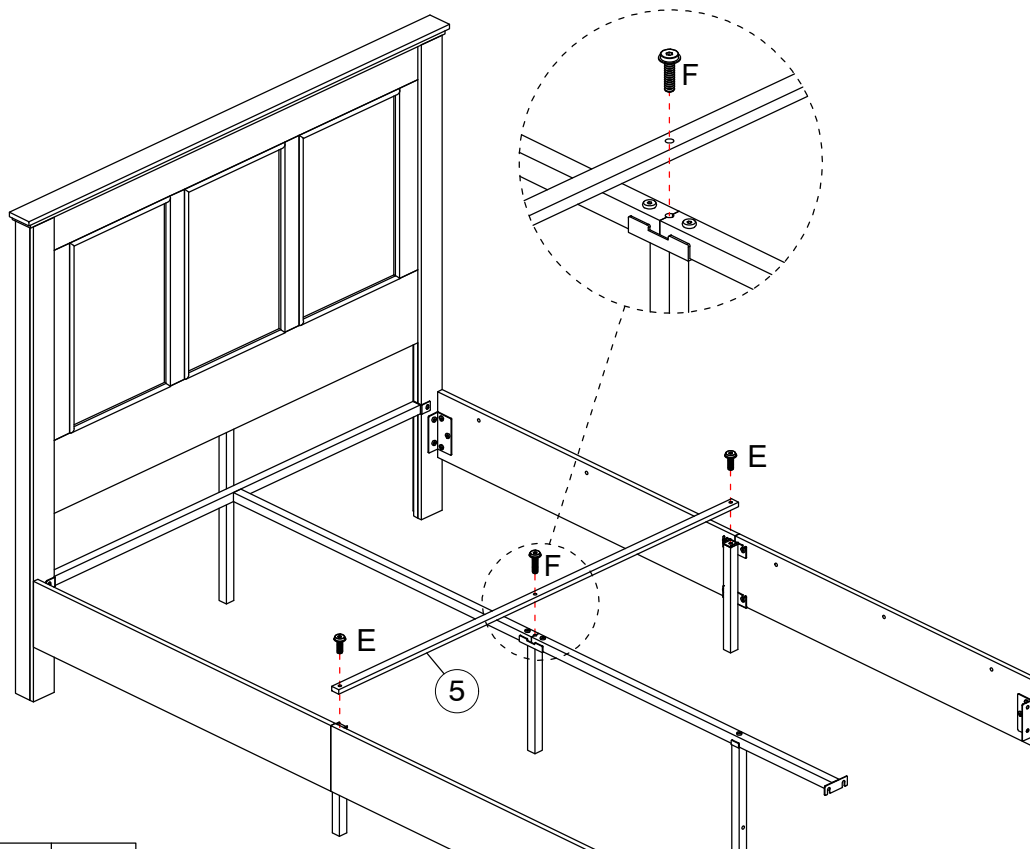

H		1PC
M8*65mm		

16



E		2PCS
M8*30mm		
F		1PC
M8*45mm		

ASSEMBLY INSTRUCTIONS

17

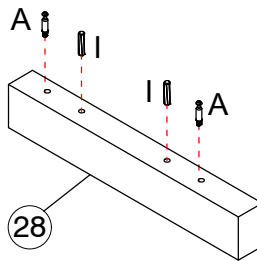
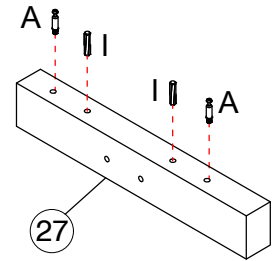
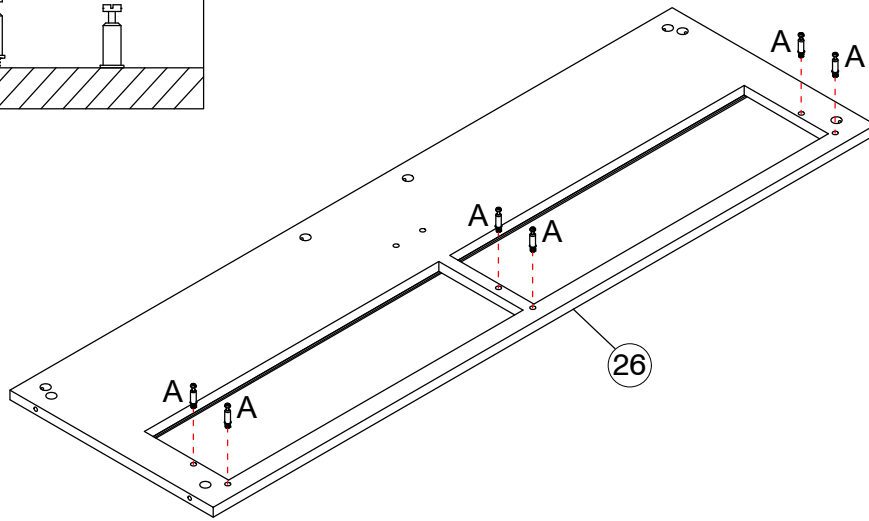
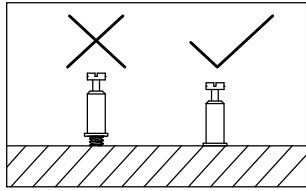

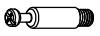
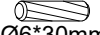
A		10PCS
I		4PCS

18

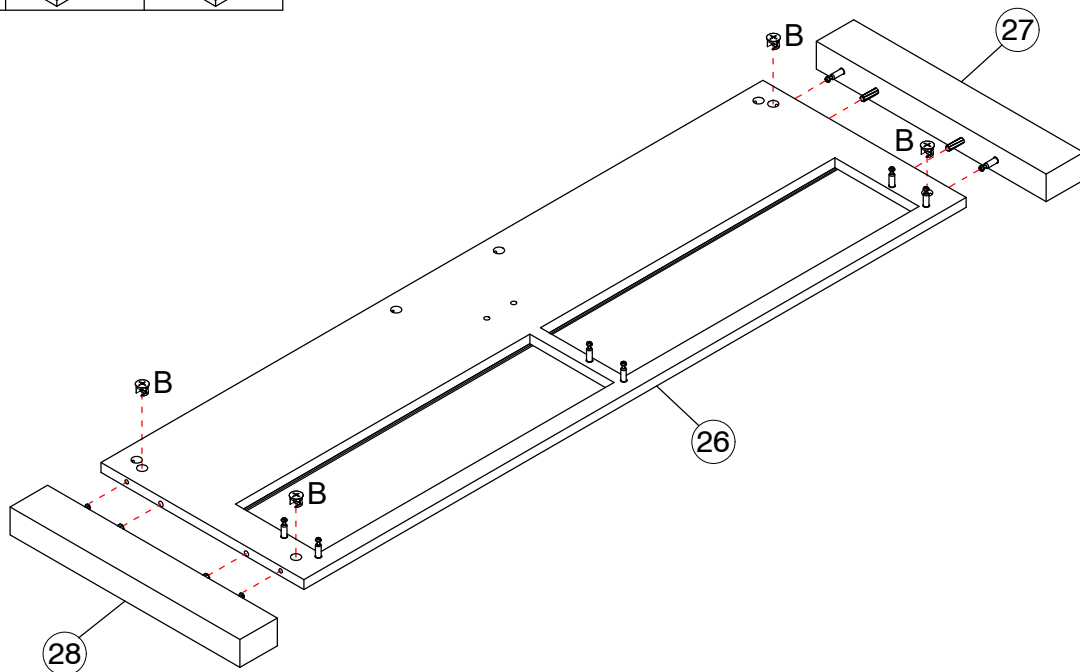
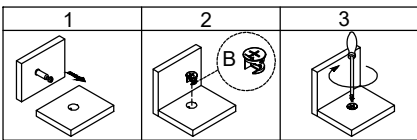

B		4PCS
---	---	------

ASSEMBLY INSTRUCTIONS

19

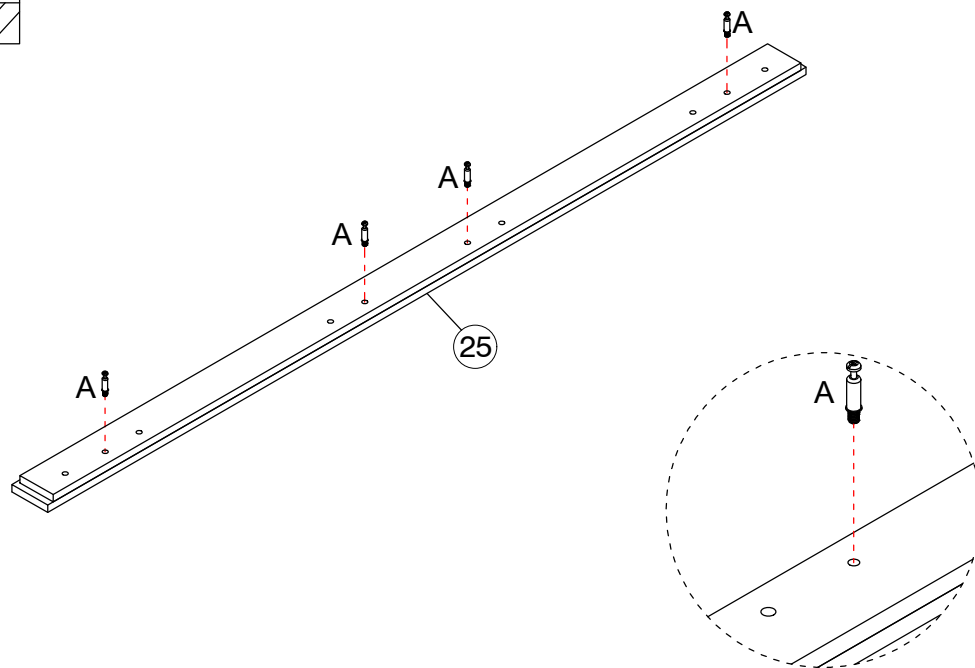
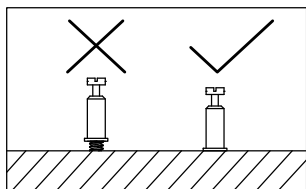

A		4PCS
---	--	------

20

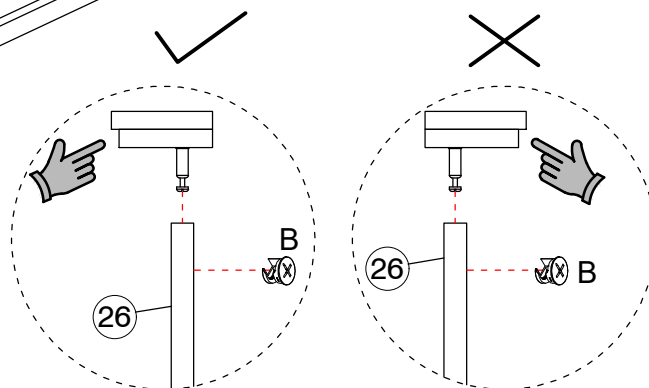
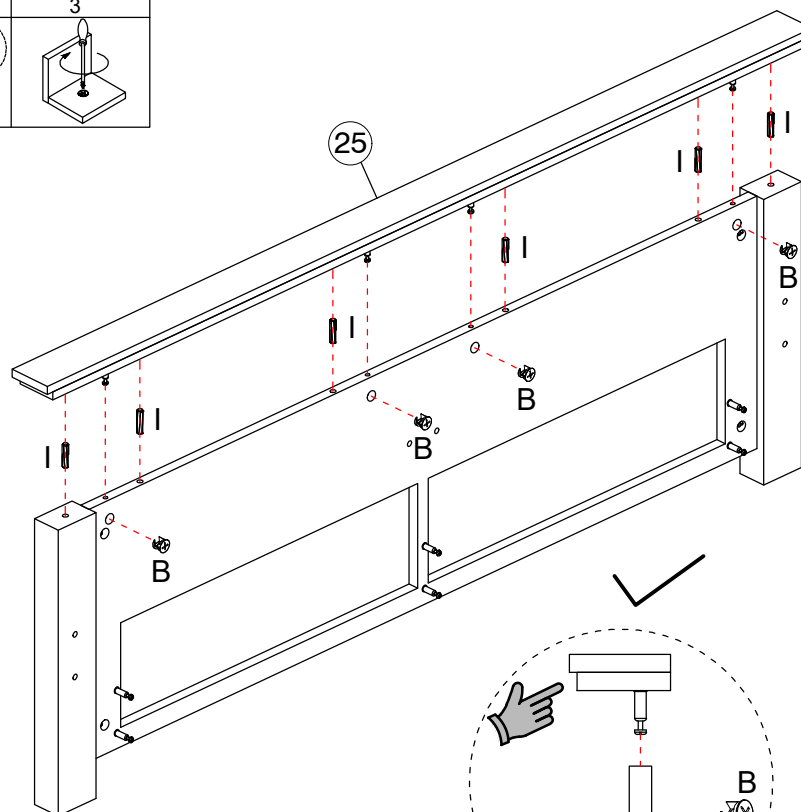
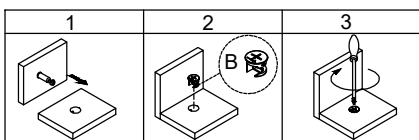

B		4PCS
I		6PCS Ø6*30mm

ASSEMBLY INSTRUCTIONS

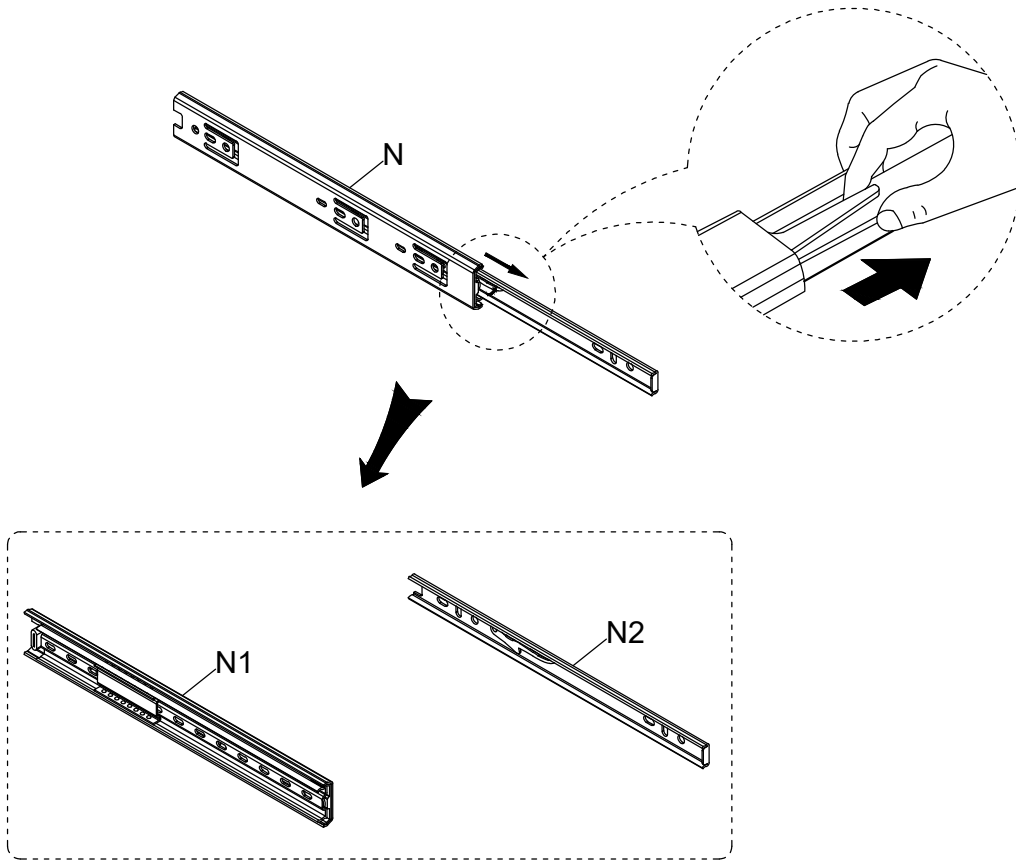

21

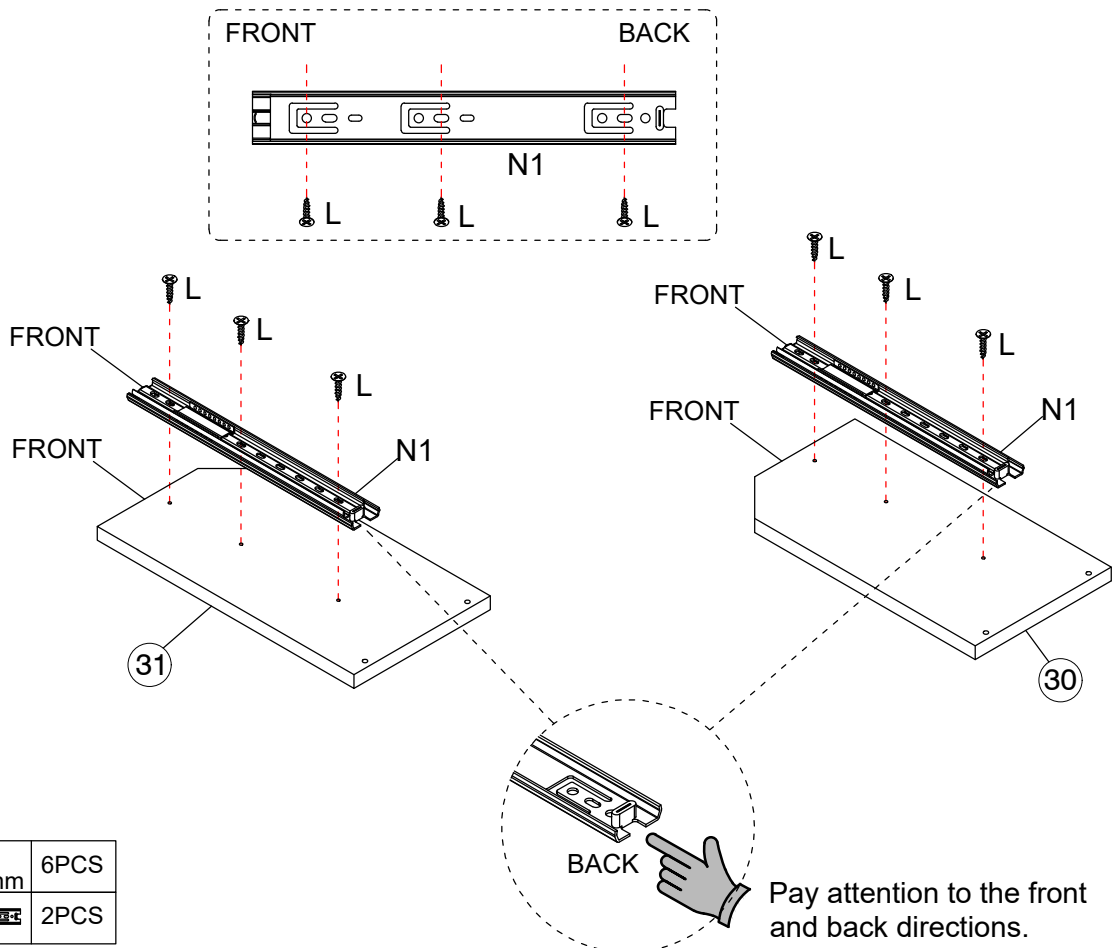

x4

22



L	 Ø3.5*15mm	6PCS
N1		2PCS

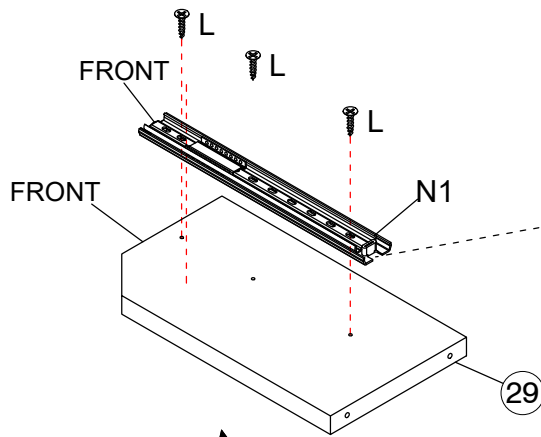
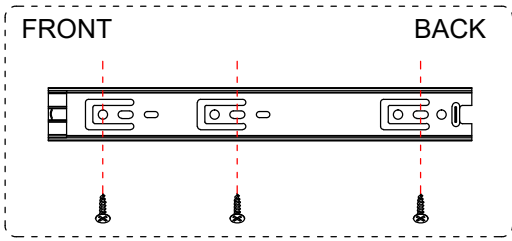

Pay attention to the front and back directions.

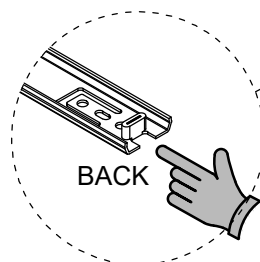
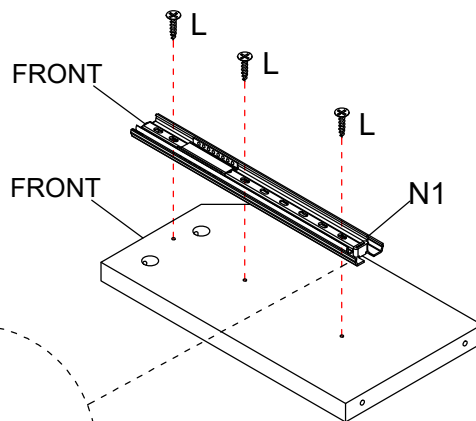
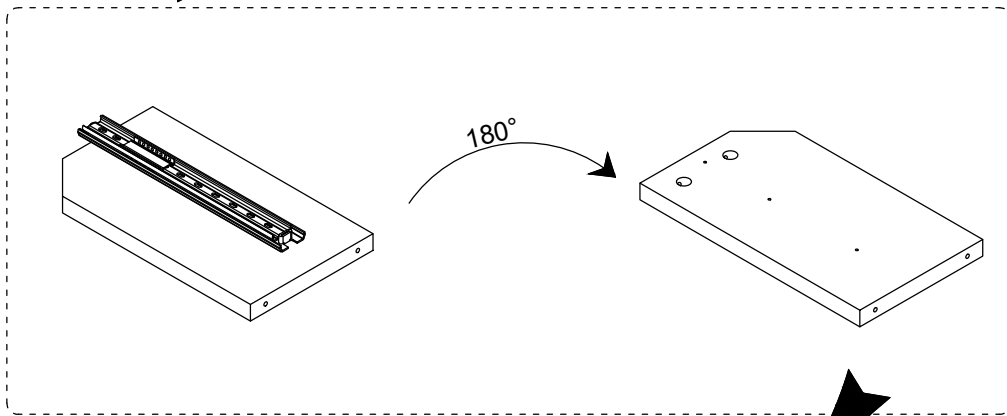
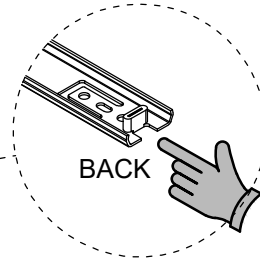

Pay attention to the front and back directions.



Pay attention to the front and back directions.

L	 Ø3.5*15mm	6PCS
N1		2PCS

ASSEMBLY INSTRUCTIONS

24

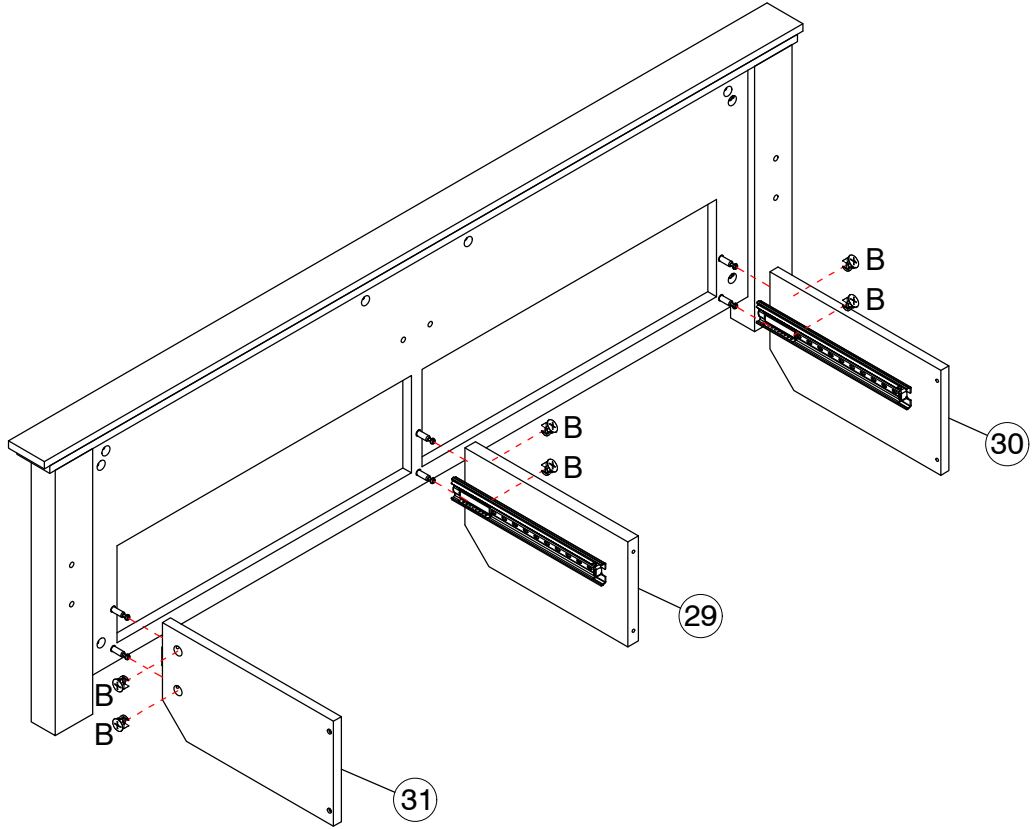

B		6PCS
---	---	------

25

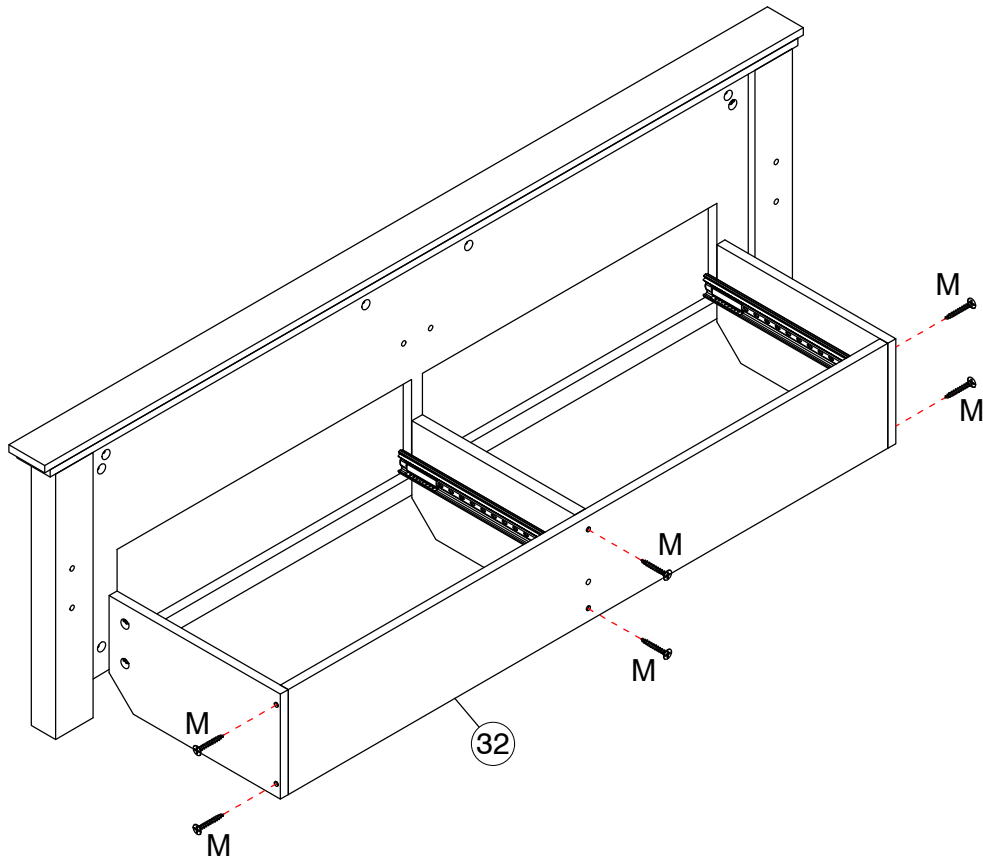



M		Ø4*30mm	6PCS
---	---	---------	------

ASSEMBLY INSTRUCTIONS

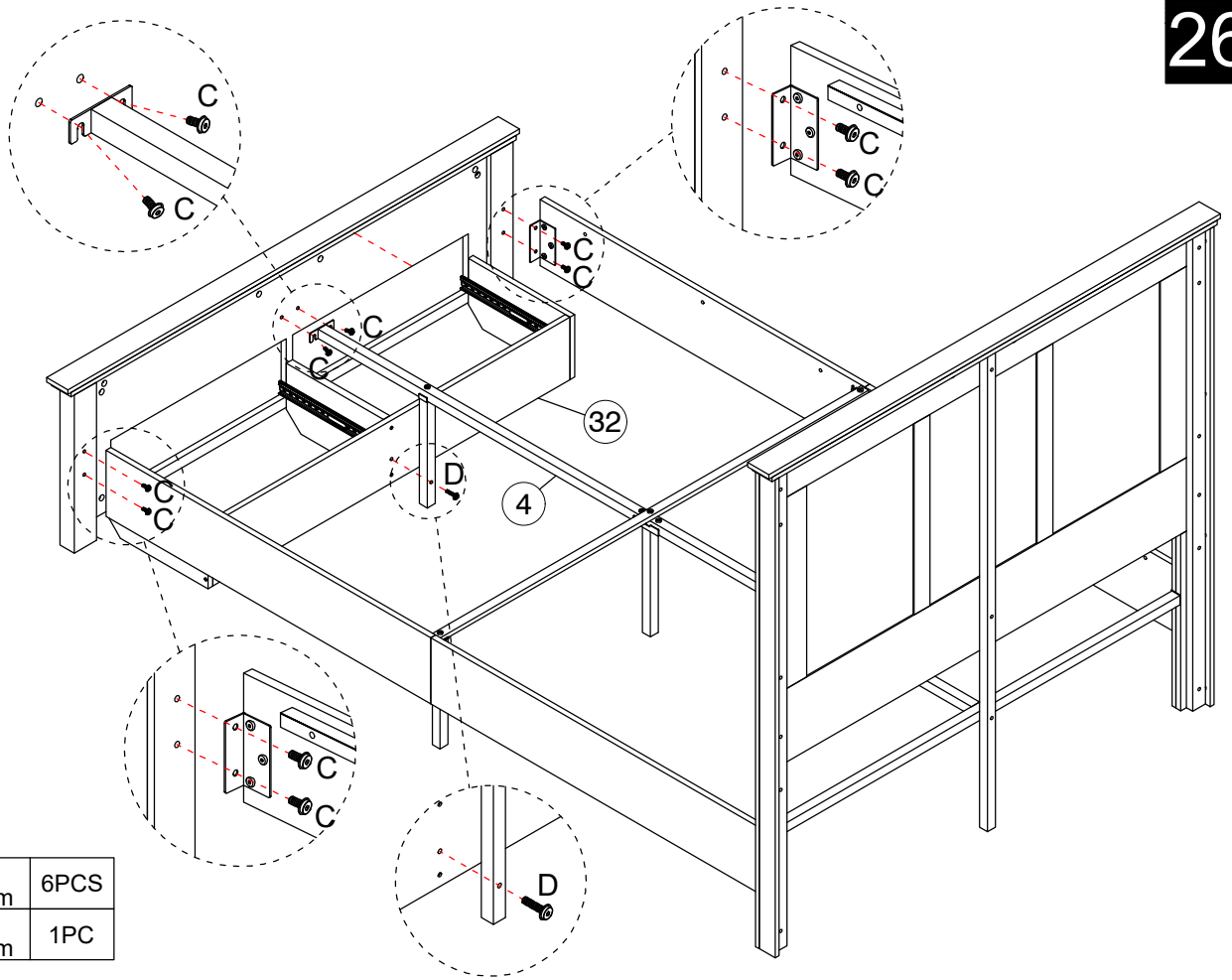
26



C	 M8*12mm	6PCS
D	 M8*35mm	1PC

27

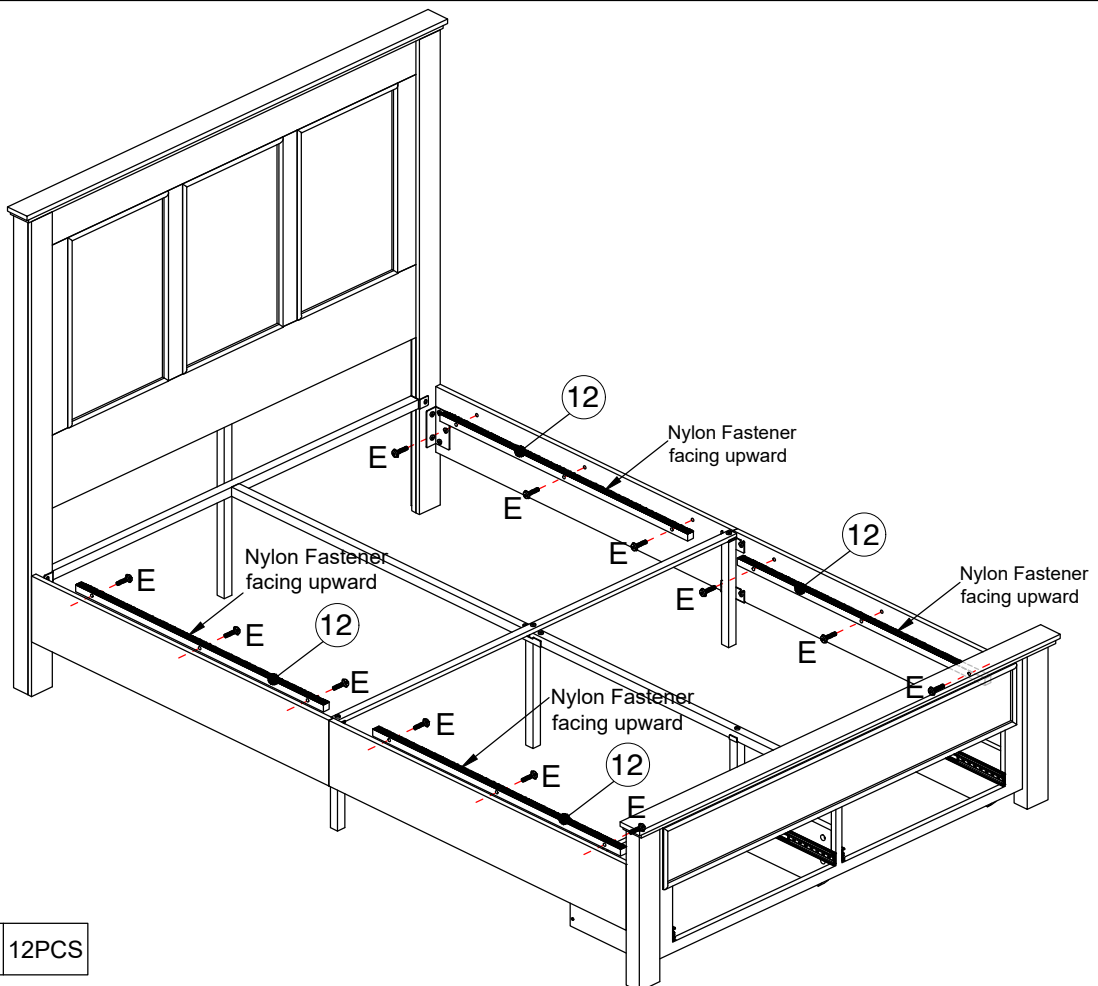

E	 M8*30mm	12PCS
---	---	-------

ASSEMBLY INSTRUCTIONS

28

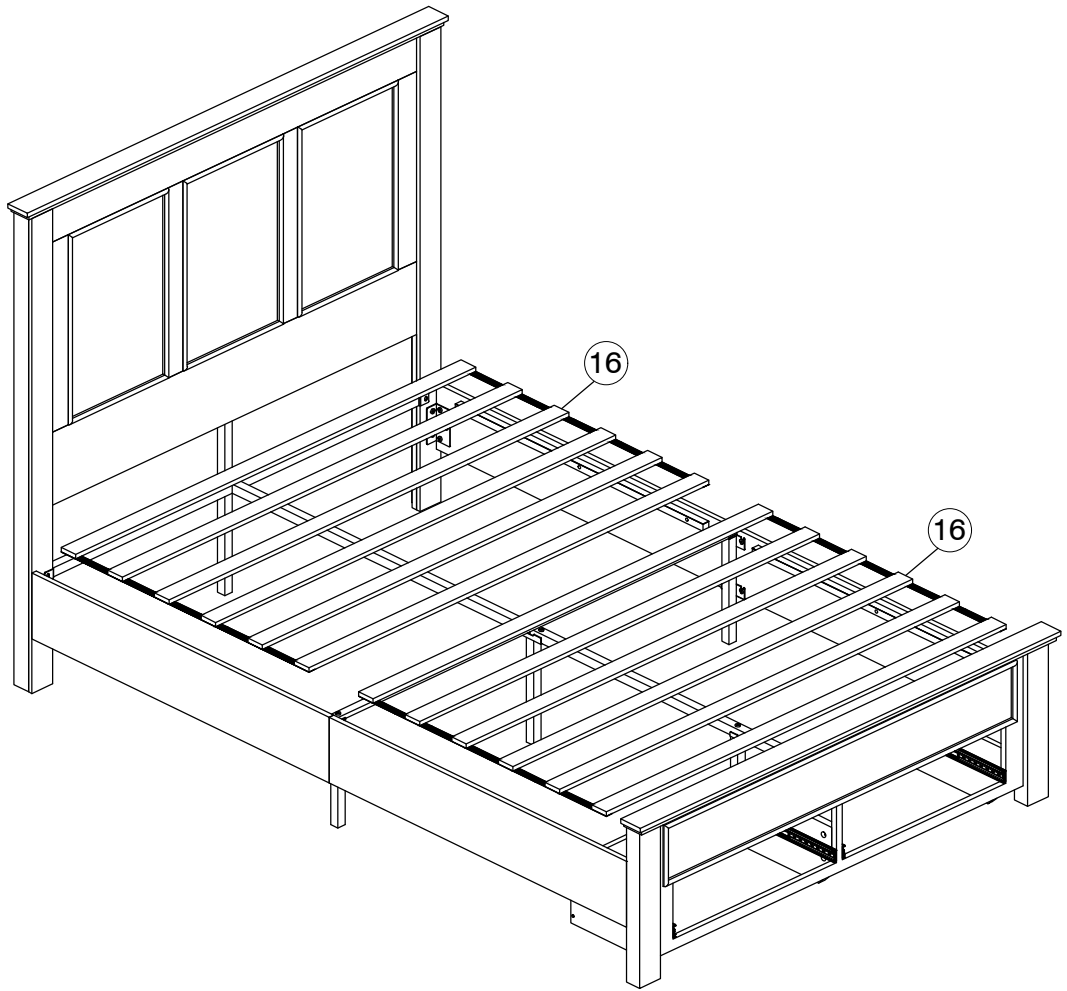

29

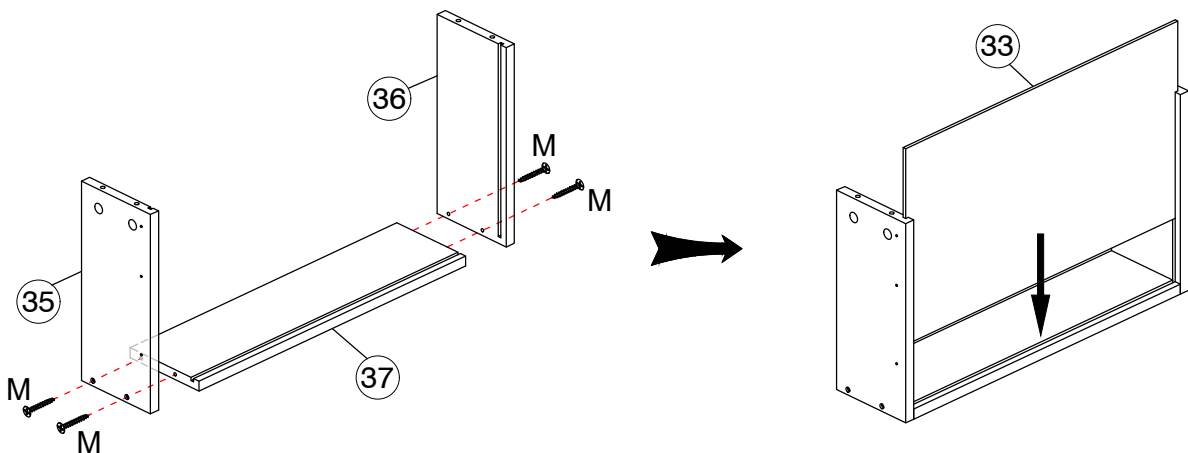
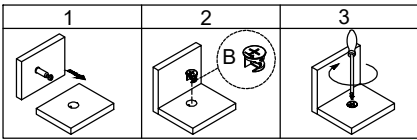

M		8PCS
---	---	------

Ø4*30mm

x2

ASSEMBLY INSTRUCTIONS

30

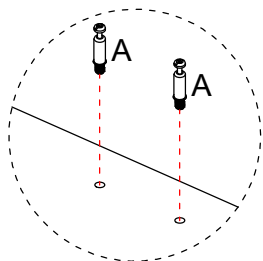
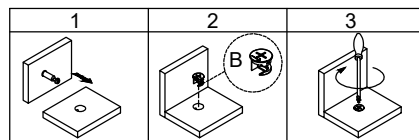
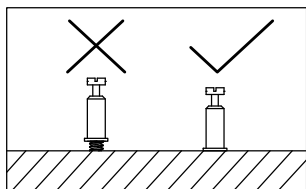

When installing, make sure the groove on part 34 aligns with part 33.

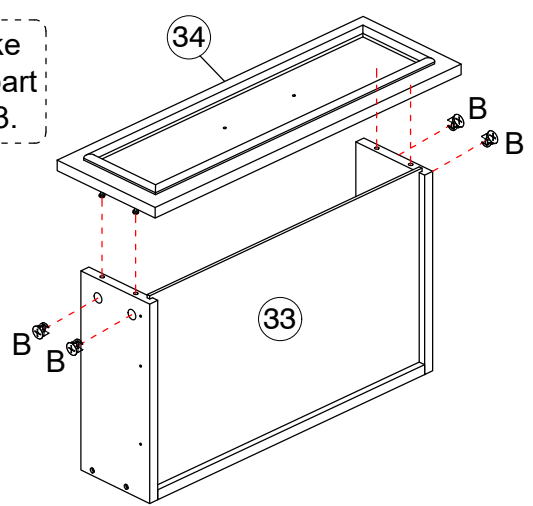
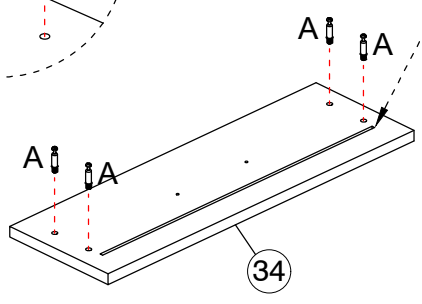

A		8PCS
B		8PCS

x2

31

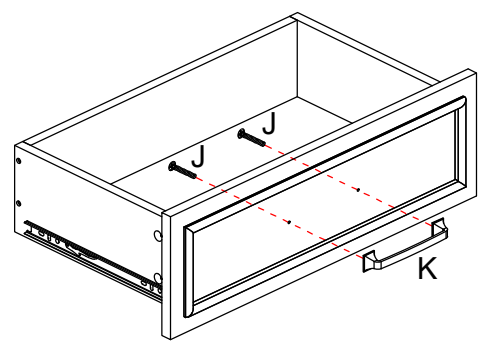
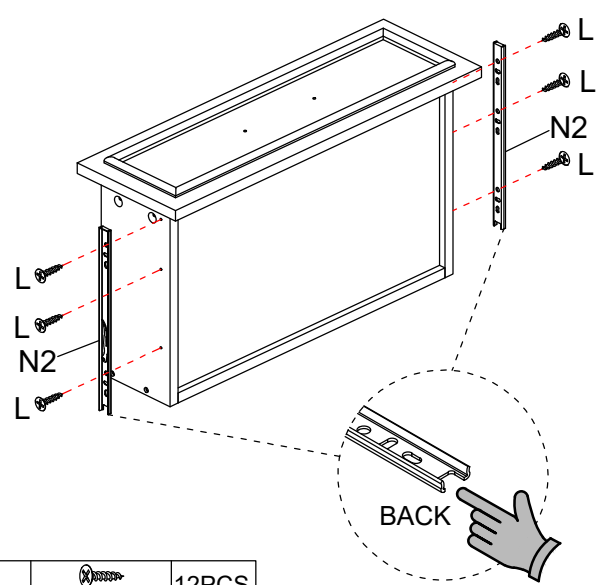
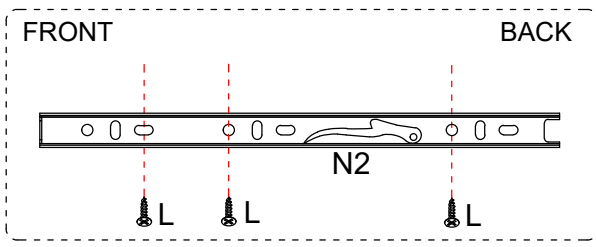

L		12PCS
N2		4PCS

J		4PCS
K		2PCS

x2

Try to find a partner to install with you, which can speed up the installation efficiency and shorten the time.

Please make sure that the balls in the tracks on both sides are pulled to the top, and then insert the tracks to ensure smooth entry.

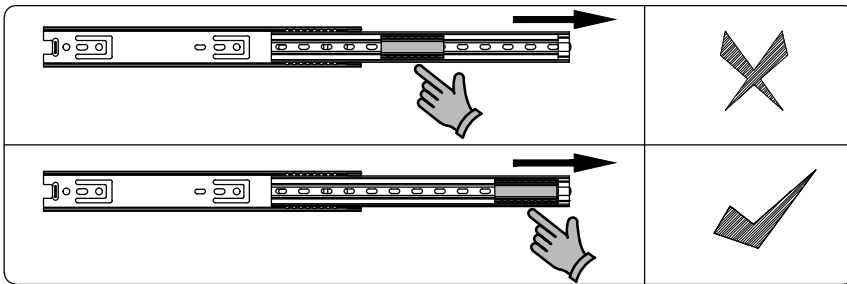

1. Drawers must be horizontally put into the cabinets.
2. Make sure both sides sliders match well to avoid damage.

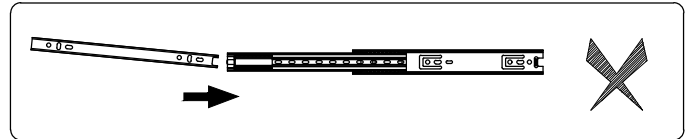
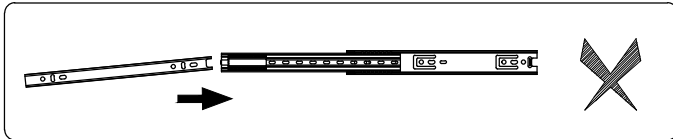
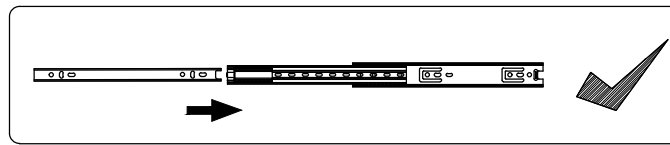

Attention:

1. Pull out the rail installed on the cabinet.
 2. Align the slide runners on the drawer with the unit and push it carefully inside until it stops.
- * If the drawer does not go in smoothly, please take it out and repeat the steps.

