

ASSEMBLY INSTRUCTIONS

COVE DINING CHAIR

Please read instructions carefully

Remove all wrapping materials, staples and packing straps from the carton. Refer to Parts List and Hardware List and ensure they are complete before you start assembling. Place all wooden parts on a clean, flat and soft surface (e.g carpet or rug) to prevent parts from being scratched.

CAUTIONS: 1) DO NOT FULLY TIGHTEN BOLTS AND NUTS UNTIL ALL PARTS HAVE BEEN ASSEMBLED.

2) DO NOT OVER-TIGHTEN BOLTS AND NUTS.

3) KEEP ALL HARDWARE PARTS OUT OF REACH OF CHILDREN.



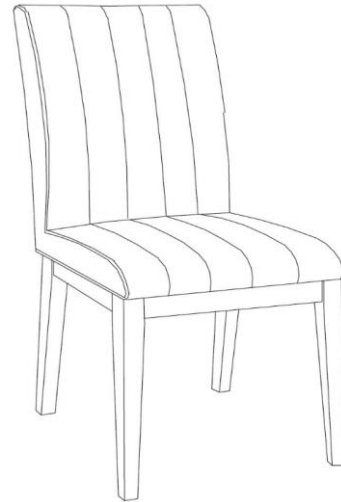

PARTS LIST (FOR 2 COMPLETE CHAIRS)

NO.	COMPONENT	QTY.
P1	CHAIR SEAT FRAME	2
P2	FRONT LEGS	4
P3	BACK LEGS with stickers (R)	2
P4	BACK LEGS with stickers (L)	2







COMPLETE ASSEMBLY

HARDWARE LIST (FOR 2 CHAIRS)

NO.	DESCRIPTION	QTY.
H1	JCBC SCREW M6X60 	16
H2	SPRING WASHER 	16
H3	FLAT WASHER 	16
H4	ALLEN KEY 	1

STEP 1 - PREPARE 8 SCREWS (H1) FOR ASSEMBLY BY INSERTING SPRING WASHER (H2) THEN FLAT WASHWER (H3) ONTO SCREW.

STEP 2 -SECURE CORNER HOLES OF THE CHAIR SEAT WITH THE SCREWS PREPARED. USE ALLEN KEY (H4) TO FULLY TIGHTEN EACH LEG. TWO SETS OF SCREWS NEEDED IN EVERY CORNER, REPEAT THIS STEP IN EVERY LEG.

H1 x 8	
M6 x 60mm	
H2 x 8	
H3 x 8	
H4 X 1	

STEP 1

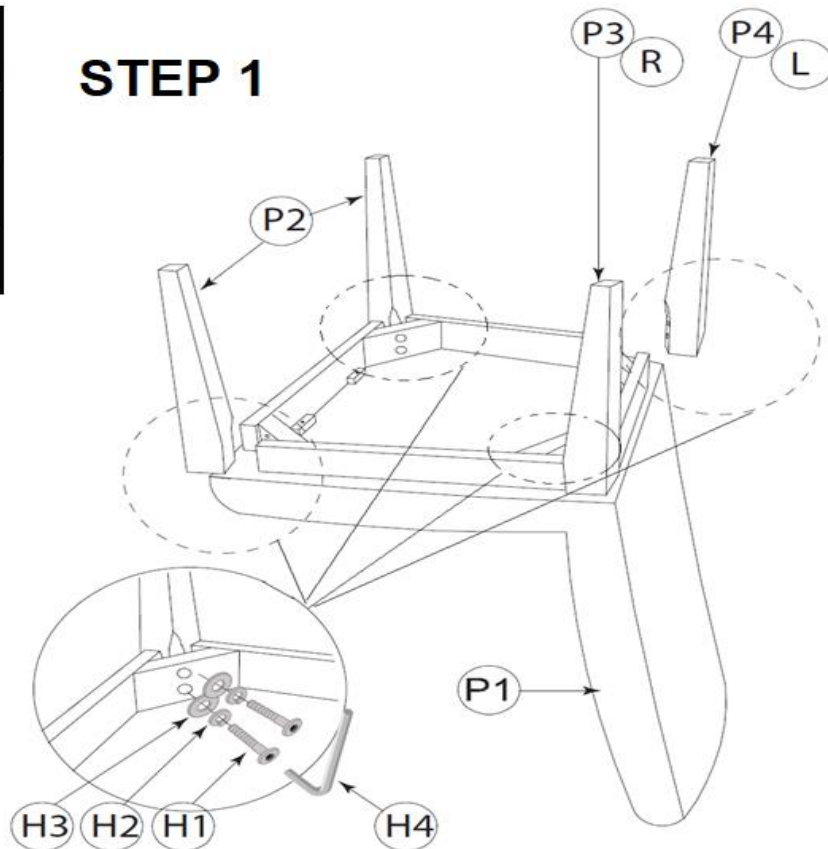

STEP 2

CARE AND MAINTENANCE

SAFETY - To avoid any risk of suffocation to children or animals, dispose off the plastic bags immediately.

CLEANING - Clean with damp cloth and mild detergent. Do not use bleach or abrasive products.

FITTINGS - Tighten bolts and nuts from time to time to ensure all parts of product are securely fitted.