

Read this instruction carefully. See hardware and furniture part list for guidance. Be sure all parts are complete, before you assemble. Place all wooden furniture parts on a clean and flat soft surface to prevent from being scratched. Follow the figure to start assembling.

- CAUTIONS :**
1. Do not FULLY - TIGHTEN the nut or nut bolt until all nut or bolt is ready assembled.
 2. Do not OVER - TIGHTEN the nut or bolt to avoid causing damages to the thread.
 3. Keep all hardware parts out of reach of children.

NOTE : THE LIST AND QUANTITY SHOWN ARE FOR 1 UNIT ASSEMBLY.

Tool needed : Screwdriver (not provider).

PARTS LIST		
ITEM	DESCRIPTION	QTY
A	HEADBOARD	1 PC
B	FOOTBOARD	1 PC
C	SIDE RAIL	2 PCS
D	CENTER RAIL	2 PCS
E	CENTER SUPPORT LEG	6 PCS
F	SLAT	1 SET
G	BED LEG	4 PCS

HARDWARE LIST		
ITEM	DESCRIPTION	QTY
1	JCBC BOLT M6 x 20mm	8 PCS
2	JCBC BOLT M8 x 50mm	4 PCS
3	M6 FLAT WASHER	8 PCS
4	M6 SPRING WASHER	8 PCS
5	WOOD SCREW M4 x 38mm	12 PCS
6	M4 ALLEN KEY (BALL SHAPE)	1 PC
7	M5 ALLEN KEY (BALL SHAPE)	1 PC
8	201 LEG BRACKET	4 PCS
9	WOOD SCREW M4 x 20mm	20 PCS
10	M8 FLAT WASHER	8 PCS
11	M8 SPRING WASHER	8 PCS
12	5/16" HEX NUT	4 PCS
13	SPANNER 13mm	1 PC

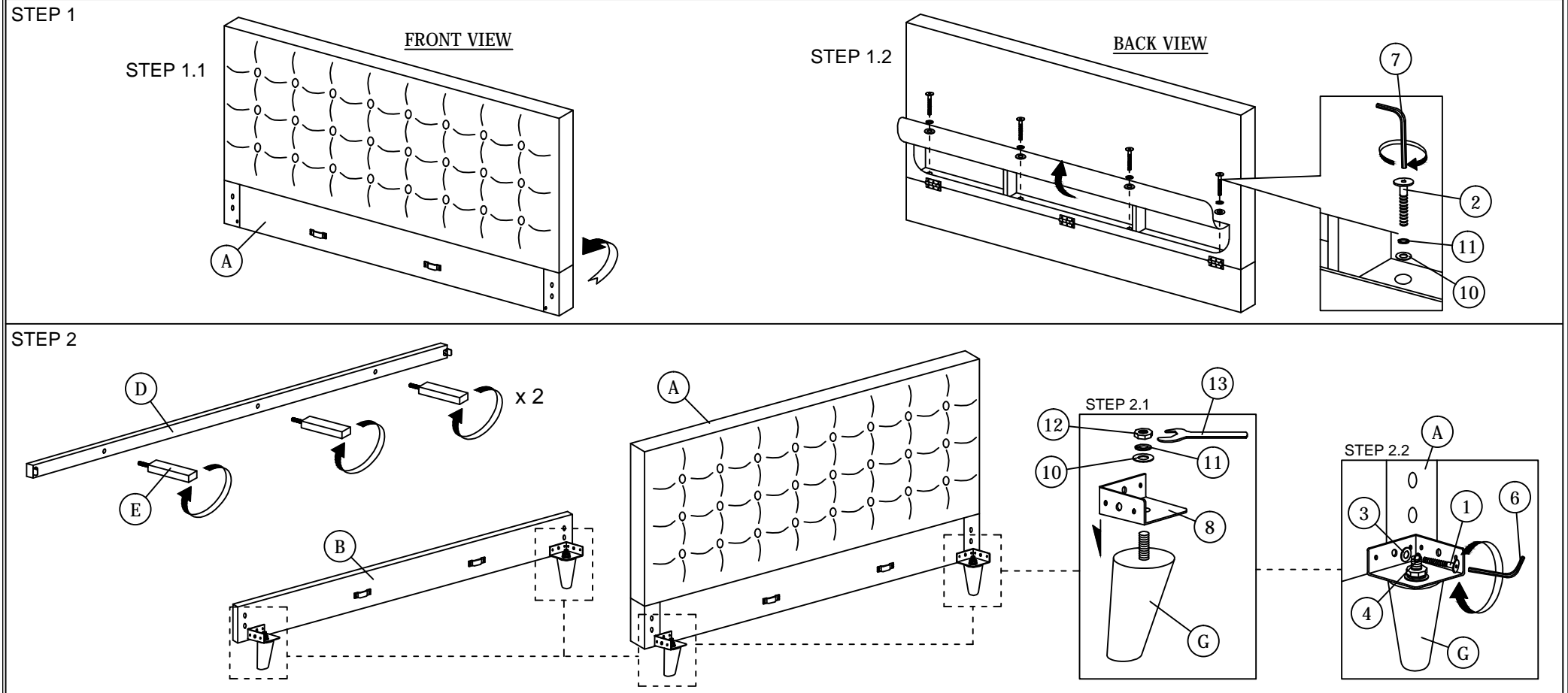

ASSEMBLY INSTRUCTIONS

STEP 3

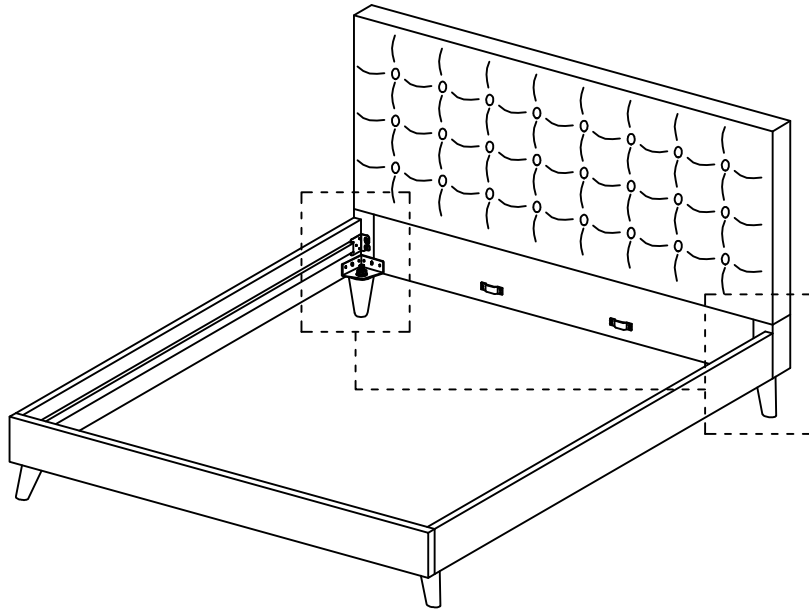

STEP 3.1

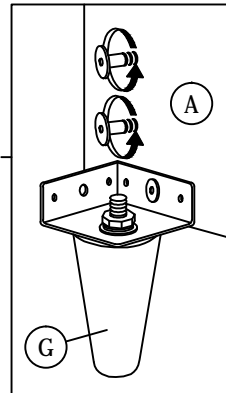

STEP 3.2

Don't screw tied.

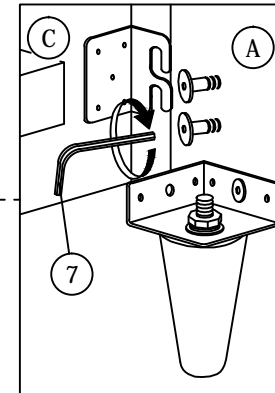

STEP 3.2

Don't screw tied.

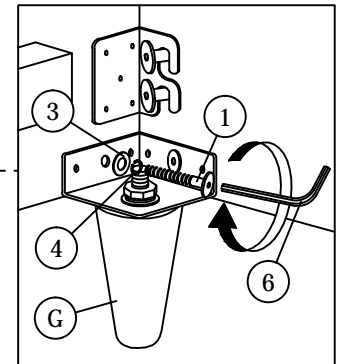

STEP 4

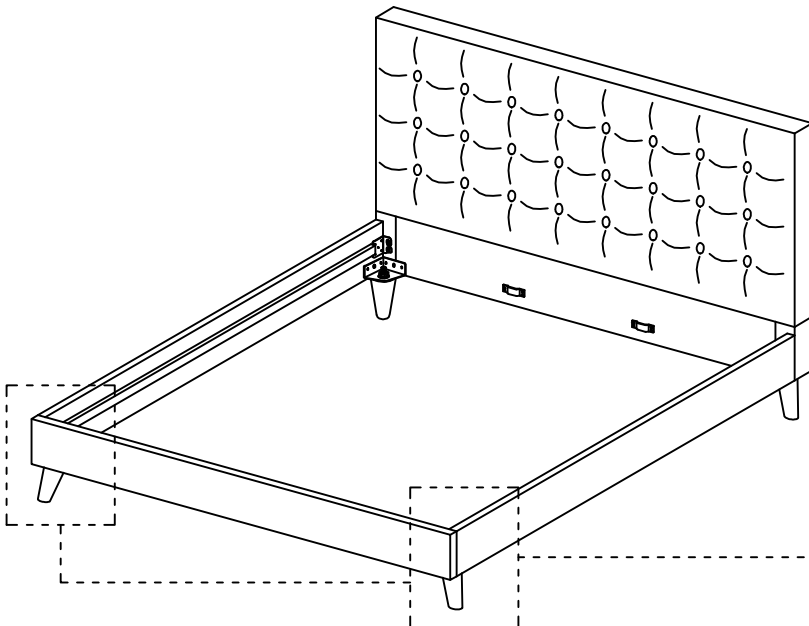

STEP 4.1

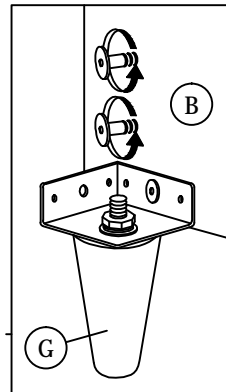

STEP 4.2

Don't screw tied.

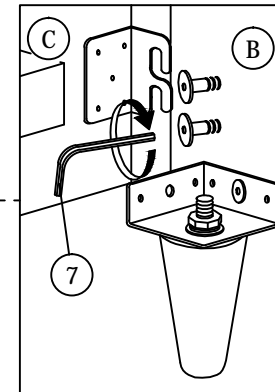

STEP 4.2

Don't screw tied.

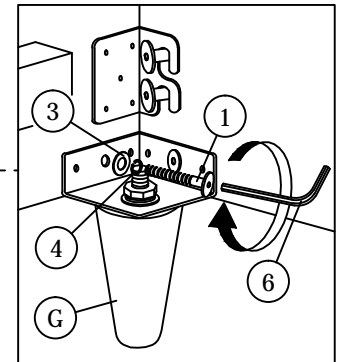

ASSEMBLY INSTRUCTIONS

STEP 5

STEP 5.1

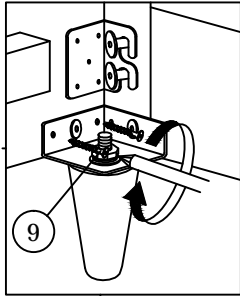

****Finish step 5,
Please screw tied the step 3,4 bolt.**

STEP 5.2

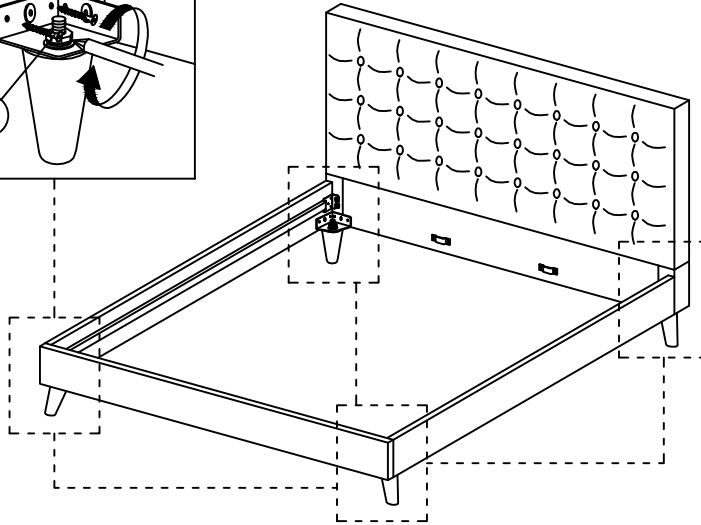
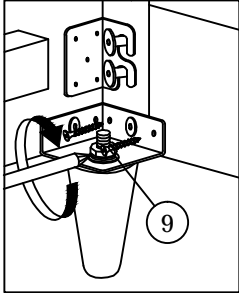

STEP 6

STEP 5.1

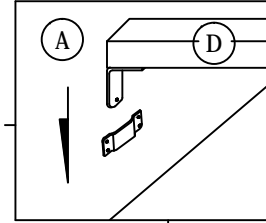

STEP 5.2

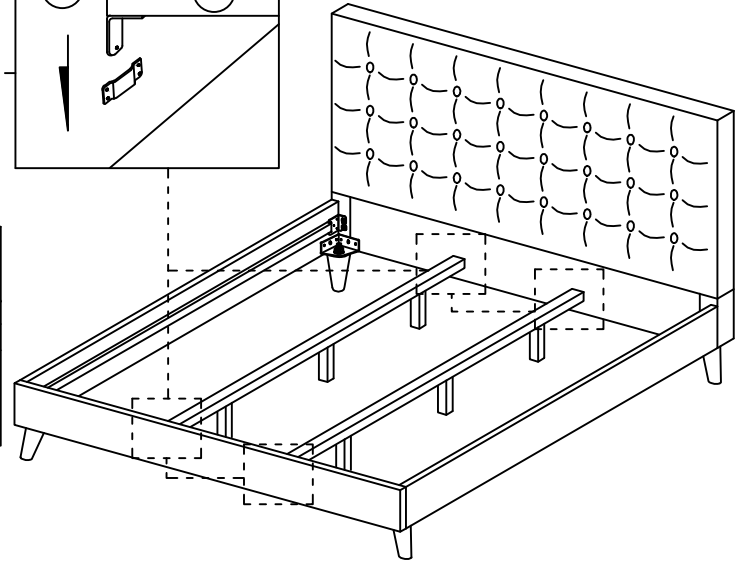
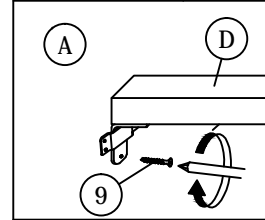

STEP 7

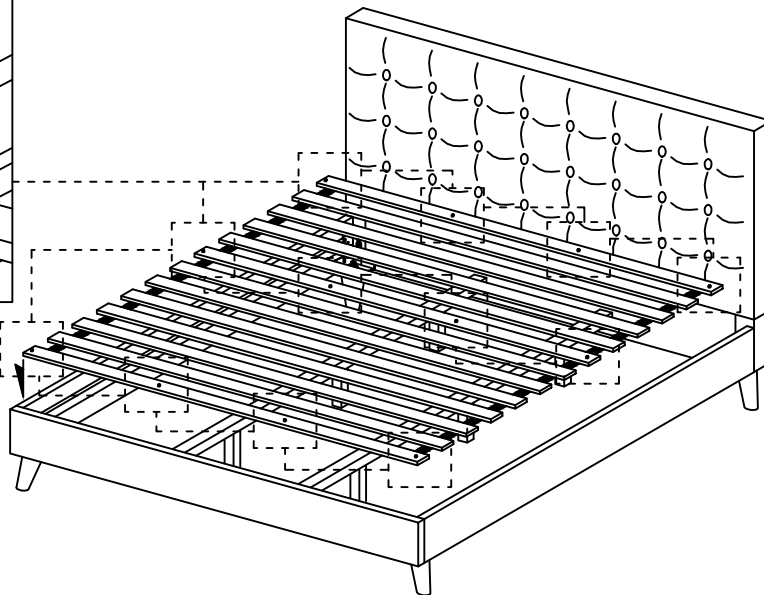
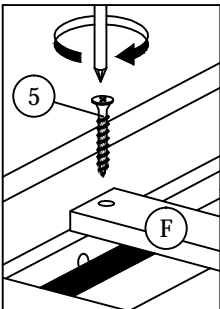

STEP 8

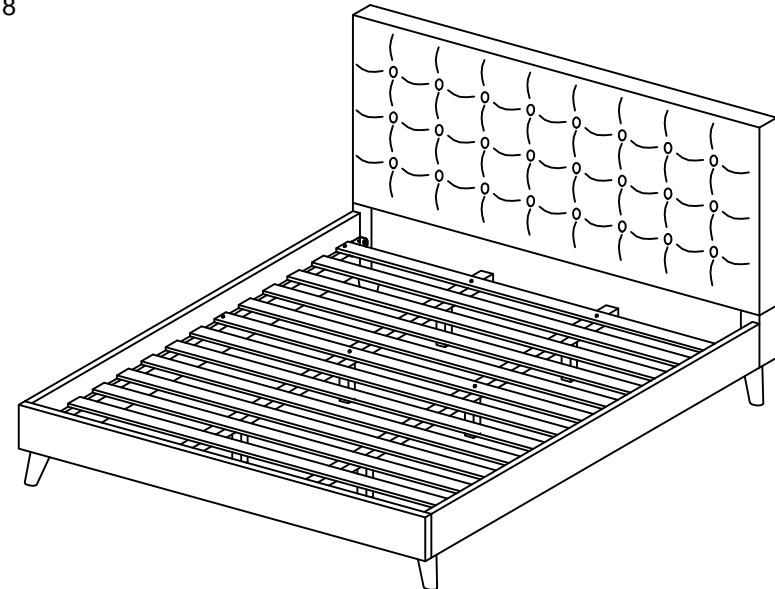

** When moving the bed position, the center support legs
must be adjust to be straight to avoid any broken problem.*