

MASSAGE CHAIR

USER MANUAL

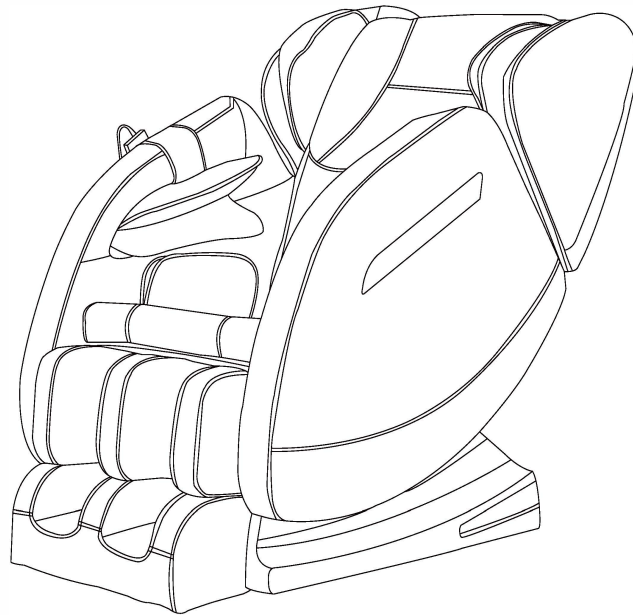

PLEASE READ AND SAVE THESE INSTRUCTIONS

Thank you very much for purchasing our massage chair. This operating manual contains important information about how to use the chair safely and correctly. Be sure that you have read all safety precautions thoroughly before using your chair. Keep this manual nearby so that you can refer to it anytime.

We reserves the right to change the product design at any time without notice. Pictures are for reference only and may vary from actual product.

CONTENTS

Safety Precautions and Maintenance

Components and Description

Main Features

Operations

Specifications

NOTICE

Our massage chair is 100% tested before leaving the factory.

IMPORTANT

1. Make sure the chair is connected to an outlet having the correct voltage. Make sure that the power cord is seated fully into the power outlet. Otherwise it may result in fire or electric shock.
2. Do not modify the plug provided with the product if it will not fit the outlet.
3. Do not use the chair outdoors.
4. Do not use the chair in any way not prescribed by the Operating Manual.
5. Do not install the chair in an area of high humidity such as a sauna.
6. Persons with the following conditions should seek medical advice before using the chair:
 - Those in the early stages of pregnancy or immediately after giving birth.
 - People with weak bones, osteoporosis, or spinal fractures.
 - People with sensory impairment caused by circulatory or other serious ailments.

- People suffering from heart disease.
 - People have a pacemaker or other medical devices prone to electronic interference.
 - People who are heat sensitive.
 - People under a doctor's care, or those experiencing unusual physical discomfort
 - Persons who are suffering from any other serious impairment or illness.
7. Keep massage sessions to no more than 30 minutes and rest after every massage.
 8. If you begin to experience pain or other physical discomfort while using the chair, immediately discontinue use .
 9. Do not fall asleep in the chair during a massage.
 10. Do not use the chair after consuming alcohol.
 11. If the chair does not start, or if there is any type of malfunction, please stop the chair immediately and turn the main POWER switch to the OFF position.
 12. Contact us for assistance regarding professional repairs or maintenance.
 13. Make sure to turn the main POWER switch to OFF after every use and to unplug the chair from the power outlet.
 14. Make sure to turn the main POWER switch to OFF and unplug the chair from the power outlet during cleaning.
 15. Never plug or unplug the chair from a power source (surge protector, wall outlet, ect.) with wet hands.
 16. Never use a wet cloth to clean the power switch, power cord, or any other electronic component.

COMPONENTS AND DESCRIPTION

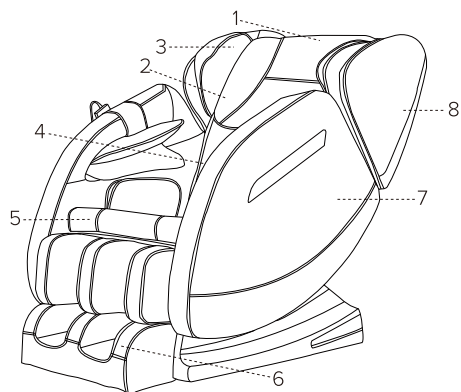

- 1.Pillow
- 2.Backpad
- 3.Shoulder Air Bag
- 4.Heater
- 5.Seat
- 6.Footrest
- 7.Armrest
- 8.Shoulder Units

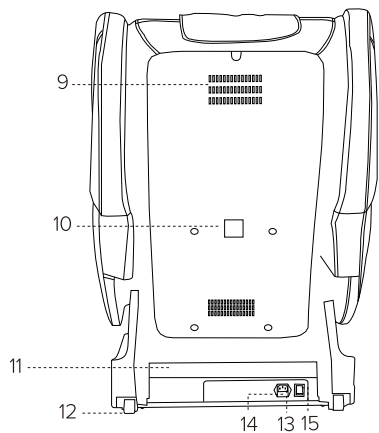

- 9.Air Vent
- 10.Specification Label
- 11.Power Supply
- 12.Wheels
- 13.Cord Connector
- 14.Electrical Fuse
- 15.Power Switch

INTERNAL STRUCTURE

- | | |
|--------------------------------|--------------------------------|
| 1 Shoulder Air
Massage Unit | 6 Back Massage
Points |
| 2 Armrest Air
Massage Unit | 7 Waist Massage
Points |
| 3 Seat Air
Massage Unit | 8 Back Heat |
| 4 Foot Air
Massage Unit | 9 Slide Rail |
| 5 Sole Air
Massage Unit | 10 Foot Roller
Massage Unit |

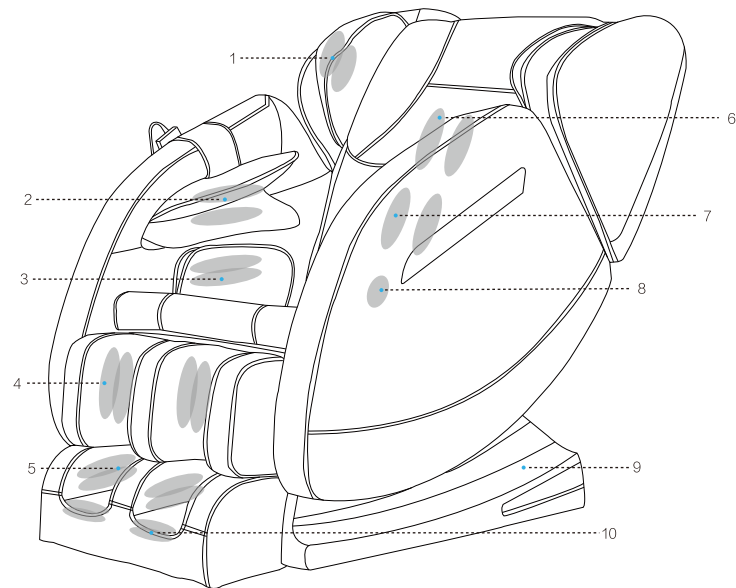

ACCESSORIES FROM BOX

- 1 TFT Display
- 2 Massage Rollers speed+
- 3 Back Massage ON/OFF
- 4 AUTO Programs Switch
- 5 Back Massage Forward and Reverse
- 6 Foot Massage ON/OFF
- 7 Buttock Airbags ON/OFF
- 8 Calf Airbags ON/OFF
- 9 Backrest UP
- 10 Heater ON/OFF
- 11 Power Button
- 12 Massage Rollers speed-
- 13 Waist Massage ON/OFF
- 14 Waist Massage Forward and Reverse
- 15 Foot Roller Speed
- 16 Airbags Strength+
- 17 Arm Airbags ON/OFF
- 18 Airbags Strength-

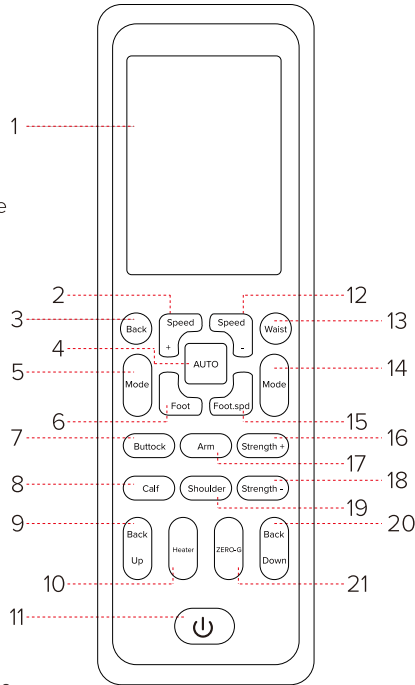

- 19 Shoulder Airbags ON/OFF
- 20 Backrest Down
- 21 One-button Zero-Gravity

MUSIC SYSTEM

Our product is designed with Bluetooth audio connection function. It can play music through connect with smart phone, tablet computer or other audio devices.

How to use:

1. Open mobile-phone/ipad/computer BLUETOOTH capabilities, and access to the search state, your device will automatically search neighboring BLUETOOTH devices.
2. In a few seconds, our massage chair name will show up under the device list, select massage chair name, and the connection complete.

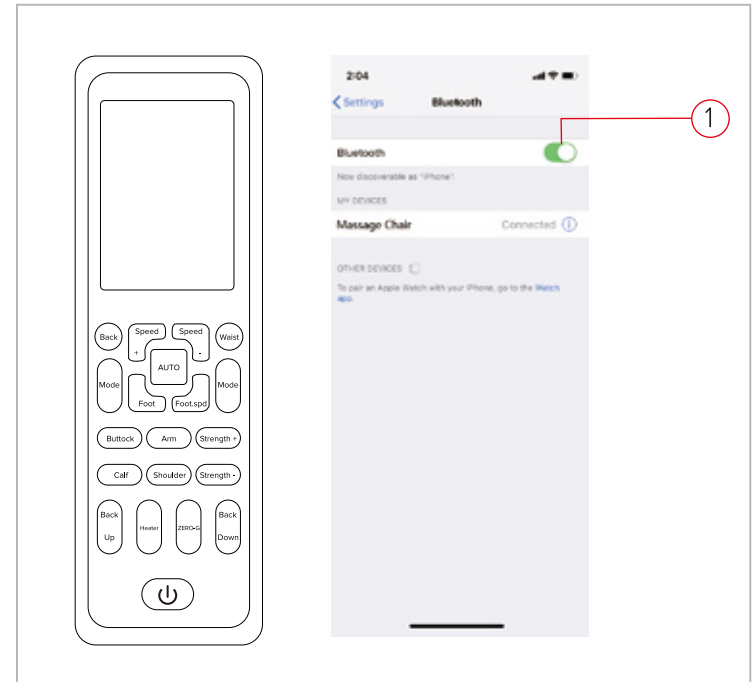

ACCESSORIES FROM BOX

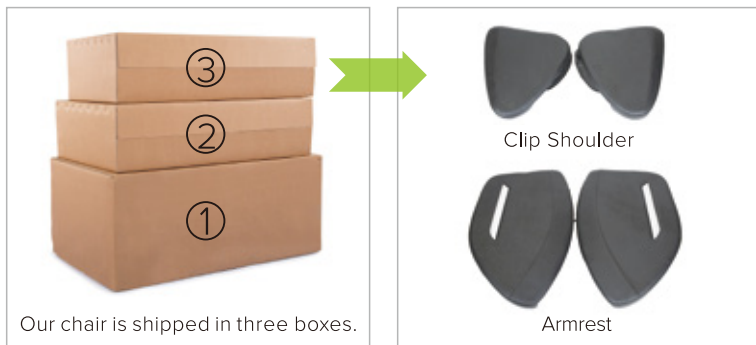

Components



INSTALLATION INSTRUCTIONS

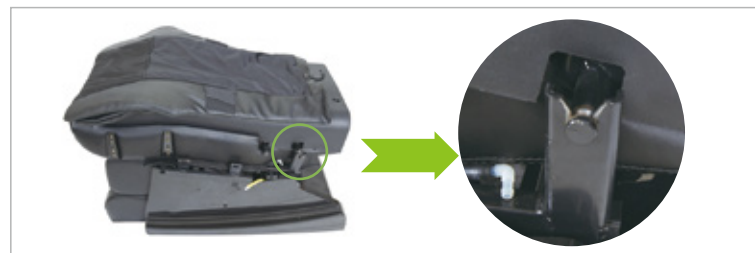

INSTALLATION INSTRUCTIONS



Fasten the armrest with two screws.



Connect air tube of armrest.



Connect air tube of near seat.



Slide the shoulder into the backrest.

INSTALLATION INSTRUCTIONS



Connect air tube of shoulder.



Connect back cushion heat wire.



Connect hand controller.

INSTALLATION INSTRUCTION



Put seat cushion into the chair.

INSTALLATION INSTRUCTION



Bottom wheel sketch map



Use screws to install left bottom wheel.



Connect air tube of backrest.



Connect wire of backrest.



Use screws to install right bottom wheel.



Connect power wire.

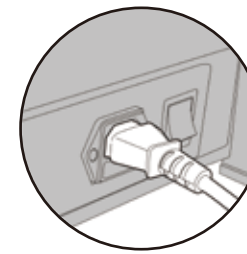

AUTO MODE

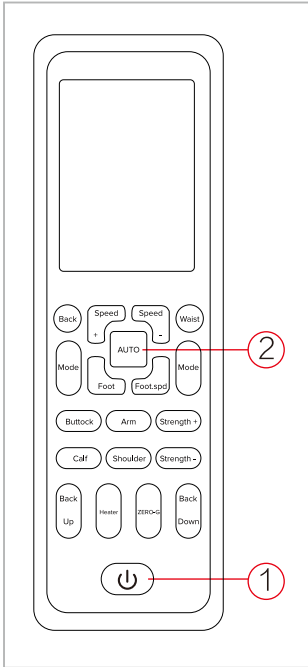

Select Auto massage mode

1.Power:when the unit is turned on it will automatically start to massage.

In automatic massage modes intensity and strength cannot be adjusted. If you would like to adjust intensity and strength please select a specific area . such as: arm , foot, or shoulders.

Press "Power" to switch time from 15/20/25/30
Press Power button for 3 seconds to turn off massage chair

2.Press "AUTO" to switch six modes:

We have six Automatic modes,press "AUTO" to switch six modes.

3.Auto massage mode will stop automatically after 15/20/25/30 minutes.

Adjusting the reclining angle

- Adjust the angle between backrest and footrest.

Leg extension settings

- Footrest unit will automatically extend to suit taller individuals.



CUSTOM MESSAGE MODE

- By selecting a single massage area, auto massage will stop
You can turn on a single massage area, or multiple areas.
- This allows you to give yourself a complete customizable massage.
- You can also adjust the strength of the air bags and intensity of the rollers.

About the remote control panel

- On/Off: press power button to turn on the chair or adjust time frame, press for more than 2 second to turn off.
- Back: manual mode up back massage
- Waist: manual mode waist massage
- Mode: up back , waist forward and reversal
- Speed + and Speed -: back roller speed adjustment
- AUTO: auto mode switch
- Foot and Foot.spd: foot roller and speed adjustment
- Buttock: hips air bag switch
- Calf: calf air bag switch
- Arm: arm air bag switch
- Shoulder: shoulder air bag switch
- Strength + and Strength -: air bag strength adjustment
- Heater: turn on heat function
- ZERO-G: recline till zero gravity
- Back Up and Back Down: backrest recline and forward adjustment when chair is working(can be adjusted to find the best position for rest when hand controller is off.)

AFTER USE

RESET THE CHAIR



Make sure children, pets, and foreign objects are away from the chair.

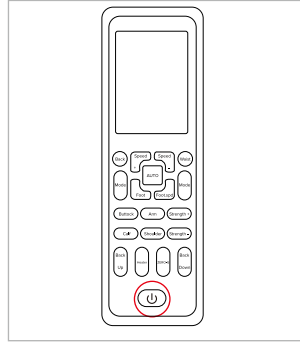

Turn off the power, the reclining seat will return to its storage position

THE MAIN POWER

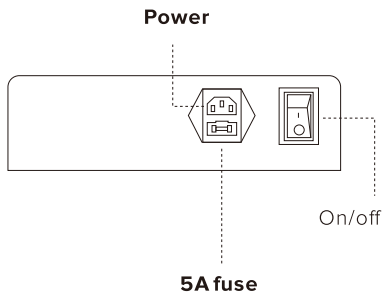

Shut down the main power

MAINTENANCE

1. Anyone other than an authorized service person must not repair or disassemble the chair.
2. Stop the main power after massage is finished.
3. If you are not going to use the product for some time, store the power cord in a dry and clean place.
4. Do not leave the chair outdoors, in direct sunlight, in a high temperature environment, or near fire.
5. Use a piece of soft, dry cloth to clean the chair. Do not use alcohol or household cleaners on the chair.
6. Do not operate the chair continuously for long periods of time.

TROUBLE SHOOTING

1. Check the power connector is fully plugged into the wall outlet if the chair doesn't work after the main power is connected.
2. The sound of the motor during operation is a normal part of the product's operation.
3. The chair will automatically power off after a massage. Press the power button to return the chair to an ON state.

TURN ON POWER SUPPLY

- 1.Plug the power cord into three core socket with well grounding.
- 2.Turn on the power switch on the bottom of massage chair.



CAUTION

- Before switching on the chair, please make sure there is no damage on the power wire and other exposed wires.
- Make sure the power switch is off before the chair is connected to electricity.

MOVE METHOD

- There are moving rollers at the bottom of the chair.
- Raise the back to the highest point.
- Switch off and plug out the chair.
- Lift the front part of the chair as showed in the figure(one person raise the front part via holding moving holder, another person push the chair when holding the top of the chair), move the chair by the rollers.



CAUTION

- Don't move it when there is people in it.
- Don't use the armrest while moving the chair, only hold the moving holder in the back and front.

INSTALLATION

Please leave the space around the massage chair when preparing the massage.

- (1) Place a massage chair in a place where there is enough space for the back of the chair to recline and the stand to rise.
- (2) Make sure that there is at least 20 cm in the back of the massage chair and at least 30 cm in front of the massage chair. In order to prevent from signal interference, please keep at least 1m away from the TV, radio and other video and audio devices.



CAUTION

Before using, please tidy up well the cables to avoid twining or damage. When the whole chair makes slide movement forward or backward to original position, please check first whether there are kids, pets or any other objects to avoid accidents. Please put carpet or other pad under the massage chair, in order to avoid any unpredictable impression on the floor.

SURROUNDING ENVIRONMENT



Keep the massage chair away from damp places (for example: bathroom) to avoid electric leakage



Keep the massage chair away from high temperatures sources (for example: stove) to avoid fire or damage to leather material

⚠️ GROUNDING INSTRUCTIONS

This product must be grounded. If it should malfunction or breakdown, grounding provides a path of least resistance for electric current to reduce the risk of electric shock. This product is equipped with a cord having an equipment-grounding conductor and a grounding plug. The plug must be plugged into an appropriate outlet that is properly installed and grounded in accordance with all local codes and ordinances. DANGER – Improper connection of the equipment-grounding conductor can result in a risk of electric shock. Check with a qualified electrician or serviceman if you are in doubt as to whether the product is properly grounded. Do not modify the plug provided with the product – if it will not fit the outlet; have a proper outlet installed by a qualified electrician.

⚠️ AFTER USING THE CHAIR

- Please power off the chair and unplug power cable from power the supply socket after using disconnect the controller and store carefully
- Please power off the chair and unplug the chair from the power supply socket when the chair is not in use, to avoid children to start the chair accidentally
- Please store well the chair if it is not in use for a long time.

⚠️ METHODS OF STORAGE

- Do not dismount the back of the chair
- Keep the massage chair free of dust
- Cover the chair with dust-free cloth to prevent dust from collecting
- Do no store in a hot, humid, damp place or in direct sunlight or heat
- Do not store in an overly cold place

⚠️ MAINTENANCE

- Before cleaning unplug from electrical source to avoid shock
- Clean the doth surface with neutral detergent or special mild detergent for cloth
- Dust can be cleaned off with a damp cloth of mild detergent and air dry
- Do not spray pesticide on device
- Specified cleaner can be used on the leather, plastic, and dried with a cloth
- Do not use a damp cloth on the electronic components which can cause shock and damage
- The leather covers (headrest, seat cushion, foot cushion) can be removed for cleaning

⚠️ KIND REMINDING

During daily use, please check whether the following phenomenon exist: Scorched smell
When touch the wire, the power is on, but sometimes off
The power supply cord is hot
Other abnormal phenomenon

⚠️ If problems happen above, please turn off power supply and contact the distributor or manufacturer for assistance.

TROUBLESHOOTING GUIDE

Problems/Issues	Possible Cause	Trouble Shooting Method
Sounds like tapping or hum sounds	Sounds from air pump, motor or other mechanical parts	Normal phenomenon
Suddenly stops working	1. Bad power connection 2. Auto program timers is up	1. Unplug and reinsert power cord to he chair 2. Normal
Does not work after power up	1. Power switch is not turned on 2. Bad connection between plug and socket 3. Massage remote is not turned on 4. Have broken power wire plug 5. Bad fuse 6. Control unit for functioning properly	1. Turn power switch on 2. Connection power cord again 3. Press power button on remote 4. Contact professional technician 5. Replace fuse 6. Contact professional technician
Roller height changes	Rollers work alternately	Normal phenomenon
Abnormal sounds suddenly while working	Maybe from over working the massage chair	1. Cut down usage 2. Contact professional technician
Can not recline the chair	Obstruction—be sure that the chair is allowed enough room to fully recline	Stop chair operation, and move obstruction
can not restore position after reclined	Problem on electric motion pole or plug under bad connection	Contact professional technician

⚠️ ATTENTION

If problems are not from above reasons, please turn off power supply and contact the distributor or manufacturer for assistance.

Note : Do not dismantle the produce by yourself, and our company shall shoulder no responsibility to the damage of the product or the inquiry of people caused by improper use. Thanks for your cooperation !

! Please keep the original packaging for our customer service

Our Chairs and accessories (the "Products") are warranted for a period of One(1) years (the "Warranty Period") against:

- Missing materials from the Products at the time of delivery;
- Defects in the manufacturing of materials used for the Products at the time of delivery;
- Failure of the Products to correspond with the description in the applicable contract of sale at the time of delivery;
- Major defects in the functionality of motors, armrests, backrest recline, and casters.

The warranty services include the followings if your chairs is under warranty and inartificial:

- i. Provide free accessories and parts.
- ii.Customer pay for the back and forth shippingcost to return for maintenance.
- Note1: If you require a return service, please show the valid warranty card and complete product package, and bear the freight of returning.

If your product cannot be repaired, we offer the following options:

- Option 1. You can contact our customer service for the depreciation and deduction of your purchased massage chair, and directly purchase any model of massage chair in our official website.
- Option 2. You can check the depreciation and deduction of your massage chair with our customer service and exchange for the equivalent cash coupon to offset of our official website for the future purchase.
- Note2: we do not accept unjustified return with non-quality problem.

Subject to the following:

- Any replacement parts shall be fully provided by Realrelax and any shipping costs shall be half-borne by the consumer;
- To benefit under this warranty,Realrelax must be notified of any defect within 14 days of the occurrence of such defect via an image or video of the relevant defect sent electronically to service@realrelaxmassage.com;
- This warranty shall be warranted for the remainder of the original Warranty Period, or 30 days, whichever is longer. Damaged cause by a drop, rough or careless handling, or other negligent action.

Warranty not covered:

- Wear and tear of Pu leather, including but not limited to cuts, scratched or damage caused by accident, abuse, misuse, water, flood , fire and other acts o nature or external causes.
- Consequential or incidental damage.
- Damage caused by personal modification or altering without permission from REAL RELAX.

! ATTENTION

For more warranty and products information,please visit our website:www.realrelaxmassage.com

FUNCTIONS



Auto



Arm



Foot



Zero-g



Air Squeeze



Music



Heating

Measurement: 39.8" * 25.8" * 17.3"

37" * 24.6" * 14.8"

39.8" * 13.6" * 21.1"

G.W/N.W:73.4LB/88.6LB

34.1LB/42.3LB

37.4LB/43.5LB

Rated Power:100W

Rated Voltage:110V-60Hz

