

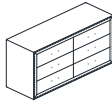





ASSEMBLY INSTRUCTION

ITEM :

BOX OF DRESSER DRESSER

ITEM	DRAWING	DESCRIPTION	QTY
A		DRESSER	1
B		LEG	4
C		SUPPORT LEG (Located in the bottom drawer)	1
D		TIPPING RESTRAINT (Affix dresser to wall) *Located in the top right side front Drawer of the Dresser	1

BOX OF DRESSER HARDWARE LIST

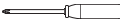
ITEM	DRAWING	DESCRIPTION	QTY
1		JCB SCREW M6x20mm	8
2		L-KEY M4x65mm	1
		SCREWDRIVER not included	

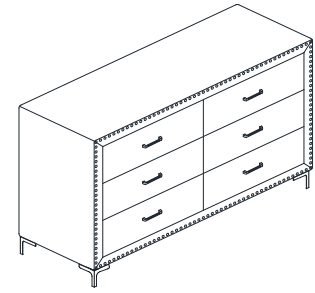

COMPLETED DRESSER ASSEMBLY

STEP 1

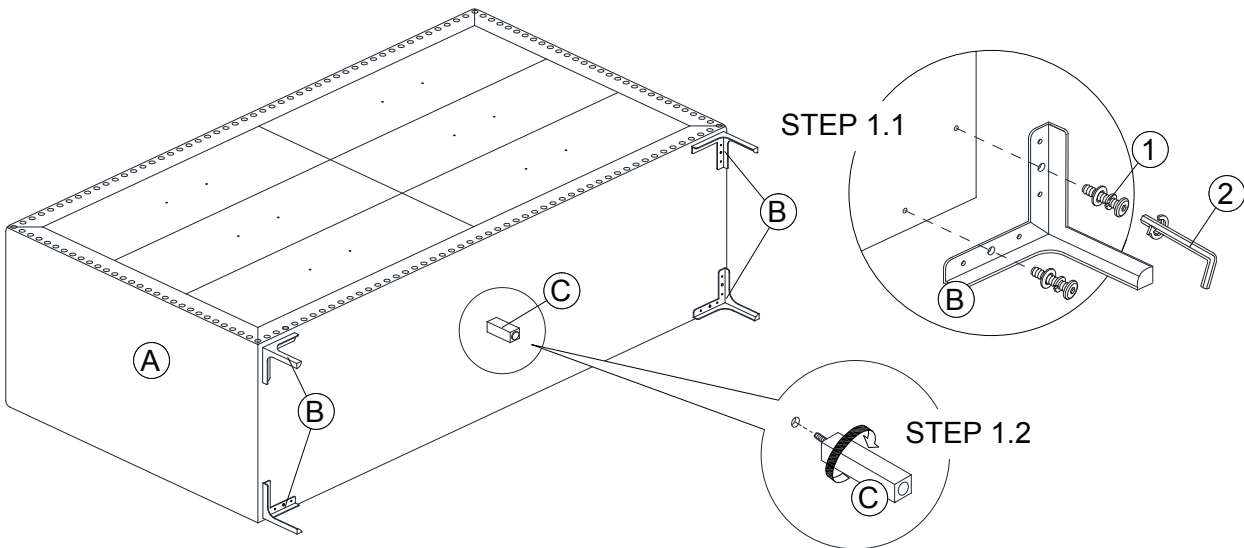

STEP 1.1

STEP 1.2

STEP 2

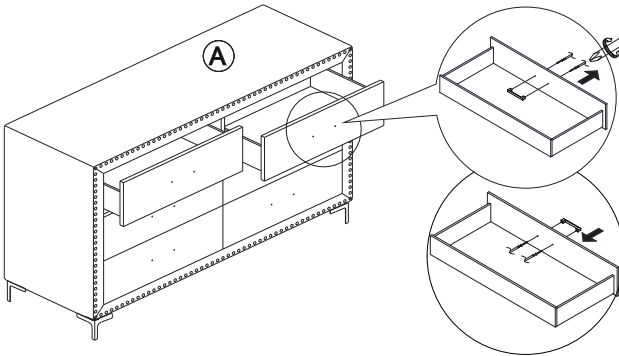

STEP 3

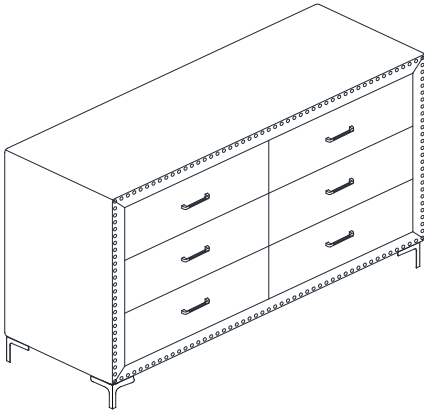

THE HARDWARE IS LOCATED IN THE PACKING ITEMS

THE ANTI TIPPING HARDWARE IS LOCATED IN THE TOP RIGHT SIDE FRONT DRAWER OF THE DRESSER.

NOTE : MUST TIGHTEN SCREWS PERIODICALLY. WITH USE SCREWS MAY BECOME LOOSE.
CHECK TIGHTNESS OF ALL SCREWS EVERY 6-8 WEEKS.

MADE IN MALAYSIA