

ASSEMBLY INSTRUCTIONS & PARTS IDENTIFICATION END TABLE

Hardware Kit

Ltr	Q'ty	Description	Size
A	1 pc	Allen wrench	4mm
B	8 pcs	Bolt	1/4"Dia*2"
C	8 pcs	Lock washer	1/4"Dia
D	8 pcs	Flat washer	1/4"Dia*3/4"
E	4 pcs	Screw	#8*1-1/2"

Part List

No.	Parts	Description	Q'ty
①	A	Leg	4 pcs
②	B	Shelf	1 pc
③	C	Storage Box	1 pc
④	D	Drawer	1 pc
⑤	E	Floor Glide	4 pcs
⑥	F	Knob/Screw	1 set
⑦	G	Drawer Stopper	1 pc
⑧	H	Drawer Glide	1 pc
⑨	I	Drawer support	1 pc



STEP 1: ▼

First pull out the drawer, remove the drawer by pushing down on the plastic drawer stop and gently pulling out the drawer.

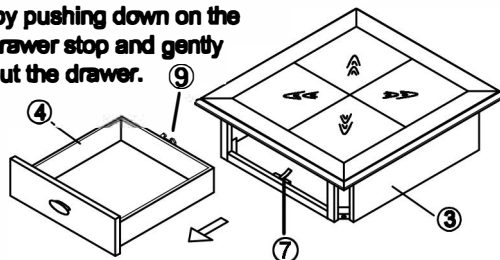

STEP 2: ▼

Carefully place the table top upside-down on a smooth, flat surface to prevent scratches during assembly. Attach three legs and to the table top with Allen bolt (B), Lock washer (C) and Flat washer (D), loosely tightening with the provided Allen wrench (A). Do not completely tighten bolts at this point.

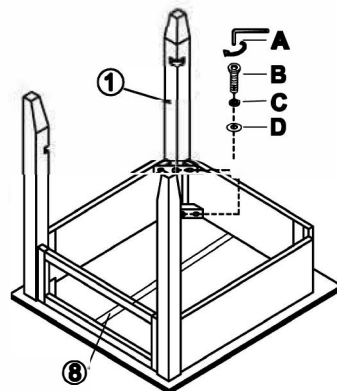

STEP 3: ▼

Insert the shelf between the three legs. Add the fourth leg and secure with a bolt, lock washer and flat washer

Secure the shelf to the legs using screws (E). Once the shelf is in place fully tighten all bolts and screws.

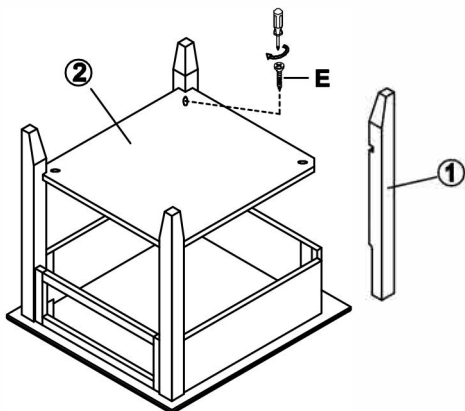

STEP 4: ▼

Carefully turn the assembled table the upright position. Put back the drawer. Assembly is now complete.

