

ESSENTIAL ASSEMBLY TIP- SADDLE STOOLS

1

When assembling your New Ridge saddle stools, avoid fully tightening the bolts while the stool is upside down. Begin by securing the bolts loosely, which allows for minor adjustments and ensures the legs are fully aligned.

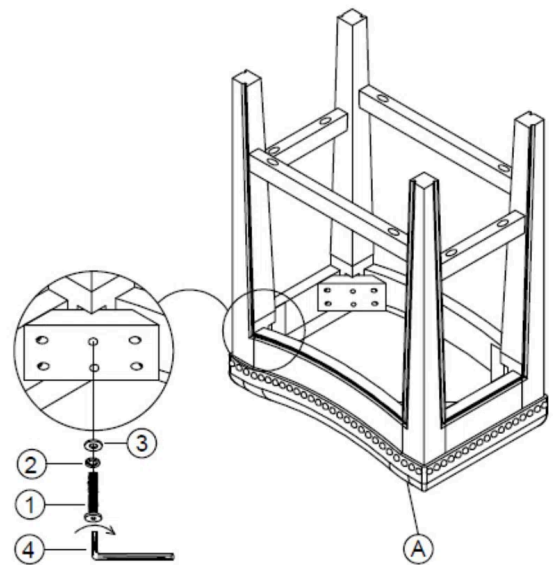

2

Once you've flipped the stool over and the legs are fully aligned, you can then tighten the bolts completely. This method not only ensures a balanced and stable stool but also prevents stress on the joints and potential damage to the materials, ultimately extending the life of your stools.

