

SHADOWSPEC SERENITY & UNITY™

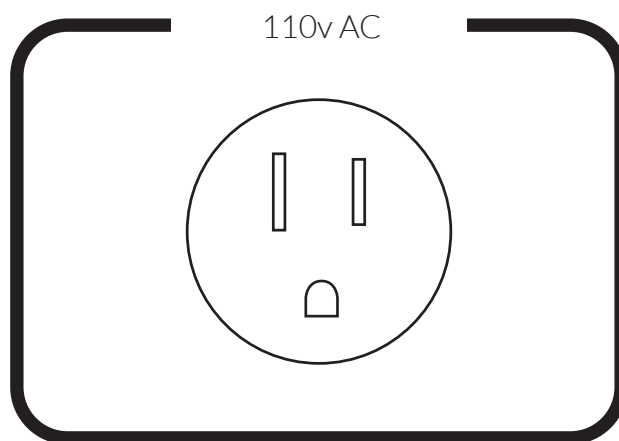

HARDWIRE KIT INSTALLATION GUIDE

P01/22



United States of America





Parts List - New Zealand & Australia Specification					
Kit Code	Part Code	Image	Part Name	Notes	Qty
UM - 510018-US	UM - 510030		12v AC/DC Adapter (US)	Capable of powering up to 4 LED Lights.	1
	UM - 510020		12v DC to 9v Converter	One per LED light. Shadowspec LED lights are strictly 9v DC	1
	UM - 510021		5-way connector	12vDC Feed wire to Voltage Converter input wires	2
	UM - 510022		Crimp Connector	Voltage Converter output to Main Spar Wire	2
	UM - 510031		Connection Cover	Connecting the feed wire to the adapter.	2
	UM - 510023		20m Feed Cable	Garden Cable. One wire has ridge to show polarity	1
	UM - 510024		Cable Ties	Cable management at the top of the Mast	4

The Hard Wire Base Kit comes with the above components. Please check your kit to ensure that it is complete. If you have a Shadowspec Serenity™ Umbrella, you will need one Base Kit per umbrella. If you have purchased a Shadowspec Unity™ you will need one Base Kit and then one additional Canopy Kit for each Canopy purchased.

Note: After your Hardwire Installation, You can still use your Shadowspec SS-1 Smart Controller, if you have one.



Additional Canopy Kit					
Kit Code	Part Code	Image	Part Name	Notes	Qty
UM - 510025	UM - 510020		12v DC to 9v Converter	Suitable for one LED light. Shadowspec LED lights are strictly 9V DC	1
	UM - 510022		Crimp Connector	Voltage Converter output to Main Spar wire	1
	UM - 510026		Cable Ties	Cable management at the top of the mast	2

NOTICE

Equipotential Bonding Compliance Obligation

This product is subject to Equipotential Bonding compliance in accordance with the Australian/ New Zealand Standards (AS/NZS 3000: 2018 Electrical Installations) otherwise known as the Wiring Rules and the USA code, NFPA 70, National Electrical Code (NEC) – 2020 edition - Article 680. If this product is installed within arms reach (NZ/AU*) or 5' (USA*) of a body of water including spa, swim spa or pool, then Equipotential Bonding **MUST** be performed by a licensed electrical person prior to the product being used. This is a mandatory requirement. As the purchaser of this product, you are responsible for ensuring compliance with this requirement at your own expense.

* Please verify the minimum distance required as stipulated by your specific regional regulations outside NZ/AU/USA



- The installation of this permanent Hard Wire Kit is best done during the install of your umbrella.
- Routing the 20m Feed Wire safely and out of sight will require some preplanning.
- The wire must enter through the bottom of the Umbrella Spigot and run up the inside of the Mast.
- For Concrete surfaces, tiling or In-Ground Anchor installs, we recommend using a concealed conduit pipe that enters through the surface plate and into the bottom of the Spigot.
- Wooden decks with underneath access require the wire to be fed through a hole that aligns with the Spigot.
- The supplied Feed Wire cable can be laid underground in your garden.
- Take care not to run it together with 220V/110V AC cabling as this is not safe practice.
- We do not recommend using the Hard Wire Kit where a portable base for the umbrella mount is used.
- The Installation method is similar for both Shadowspec Unity™ and Shadowspec Serenity™ umbrellas.

Tip: Always Label cables where possible. This makes it much easier to do installs and finding faults later.

General Notes and Safety



- We recommend consulting a certified electrician prior to installation.
- Unplug the 12v AC/DC Adapter from the wall socket during install process or when not in use.
- Never install the 12v AC/DC Adapter in or near your Umbrella. Maintain at least a 2M distance.
- Only use the supplied 20m 12v DC Feed Cable into the umbrella.
- Ensure that the 12v AC/DC Adapter is plugged into AC power socket that has been installed by a certified electrician and is protected from the outside elements.
- Do not cut or extend the AC Power Lead on the 12v AC/DC Adapter.
- Do not submerge the 12v AC/DC Adapter or any connection point into water.
- Please take care to wire your umbrella light using the correct DC polarity: Do not mix the + and - wires as this will damage your umbrella LED light.
- Ensure all wire connections are secure and sealed with the supplied gel filled connectors.
- Do not connect any other 12V devices to the supplied 12v DC adapter as this will void your warranty.

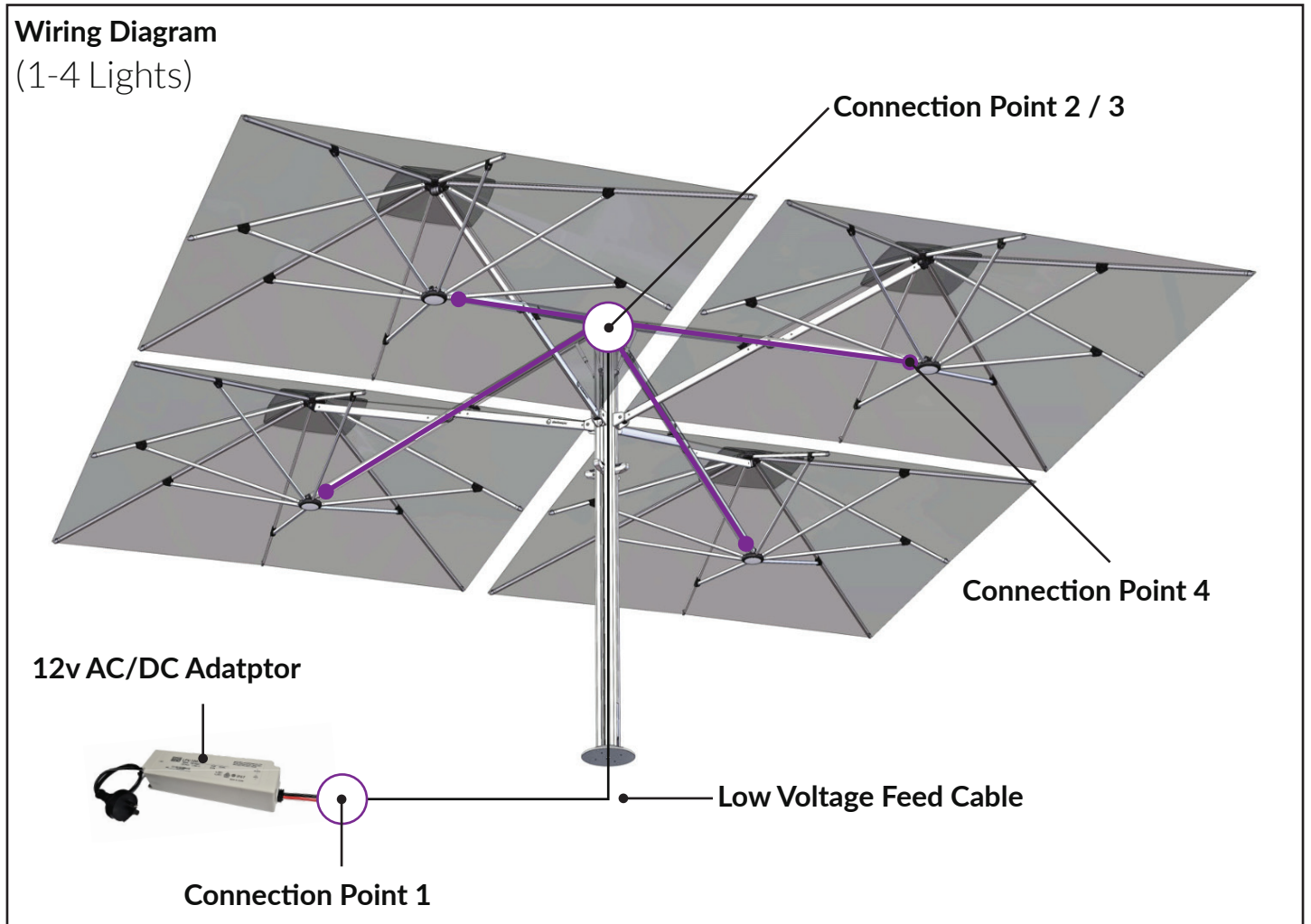

Components for each Connection Point

Connection Point 1

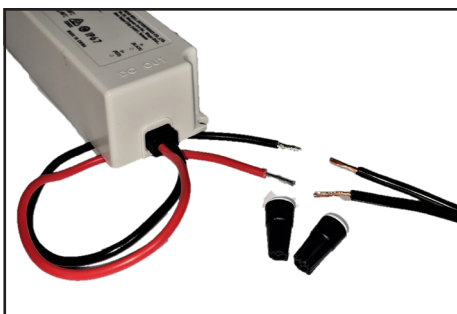
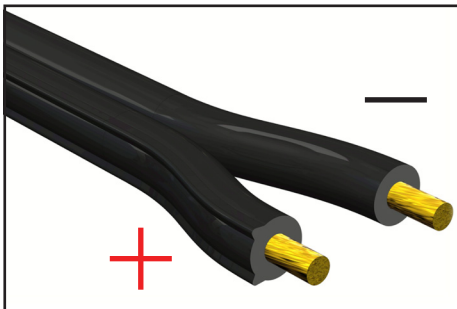

Connection Point 2

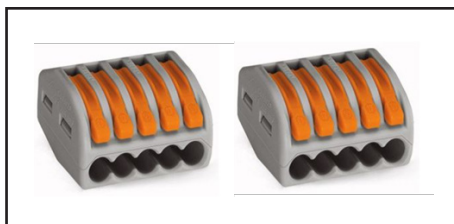

Connection Point 3



Note: 12v DC to 9v Converter is shared between Connection Point 1 & Connection Point 2

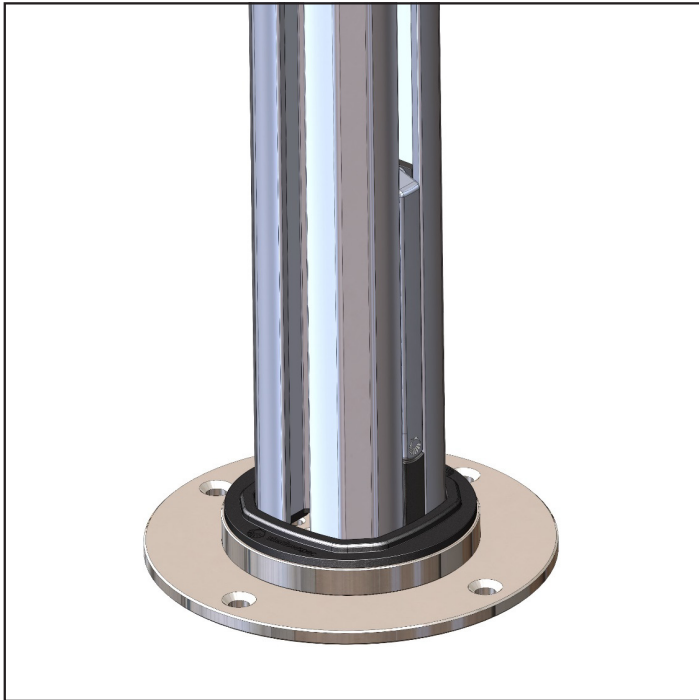

If you are retrofitting the Hardwire Kit - Remove your Umbrella from the Spigot.

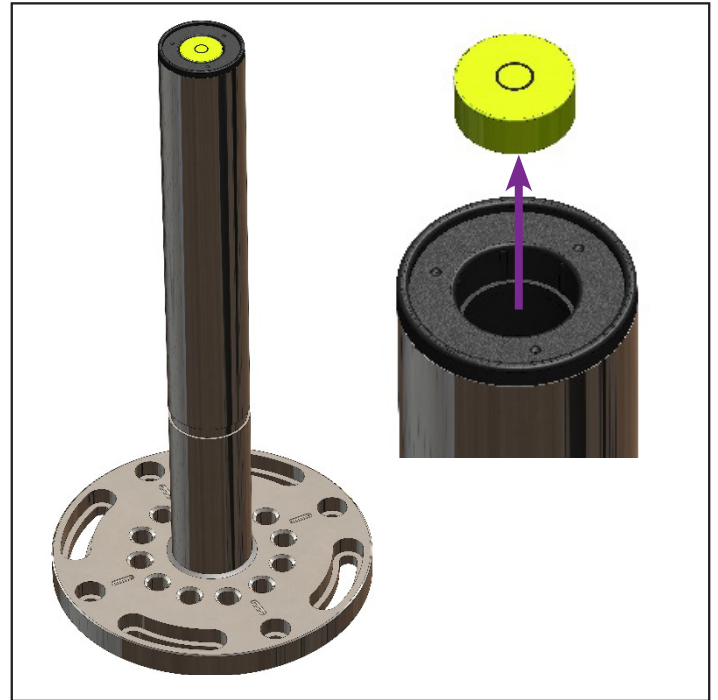

Remove the Spirit Bubble from the top of your Spigot

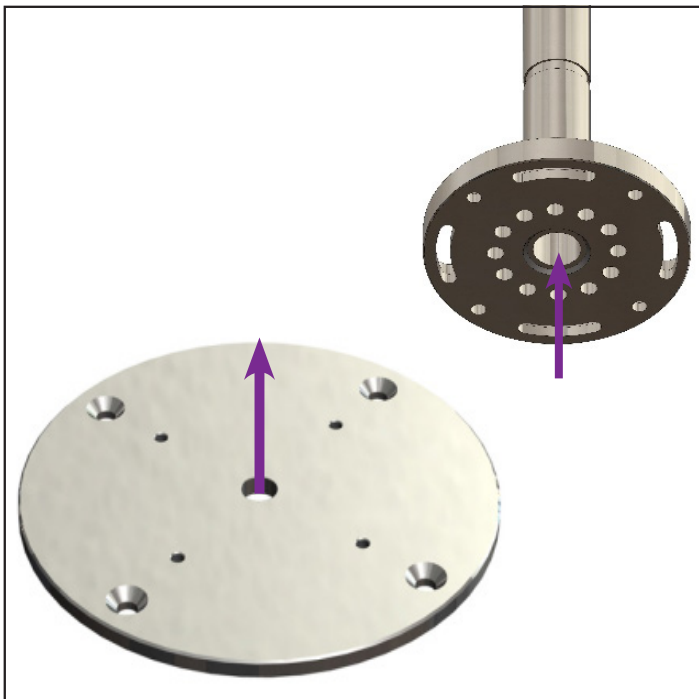

Feed the Feed Cable through the Wire Feed Hole on the Surface Plate and Spigot



Run the Feed Cable through the Spigot and into and through the Mast.

Tip: Shadowspec Serenity and Unity Spigots have the same wire path

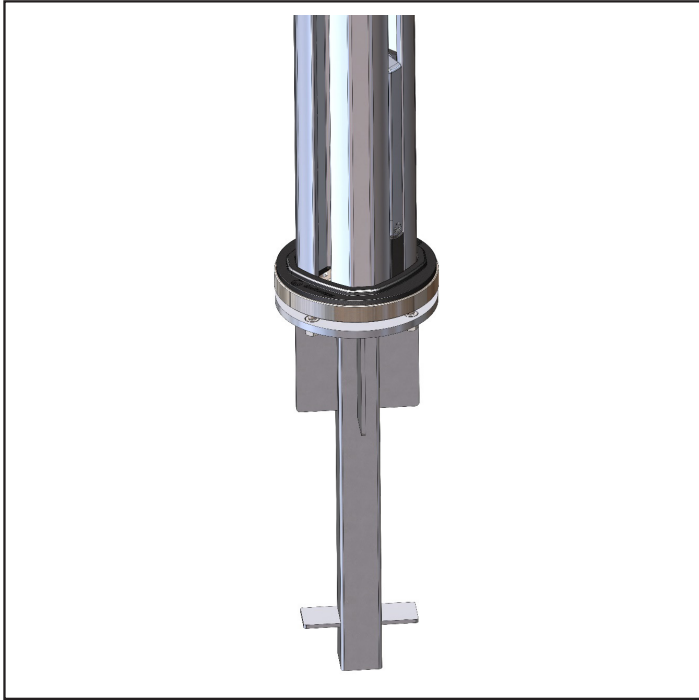

If you are retrofitting the Hardwire Kit - Remove your Umbrella from the Spigot.

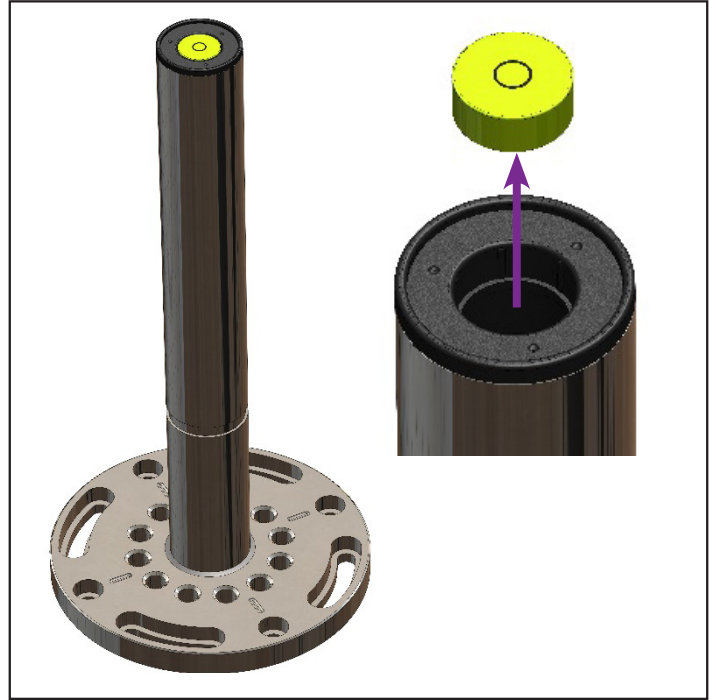

Remove the Spirit Bubble from the top of your Spigot

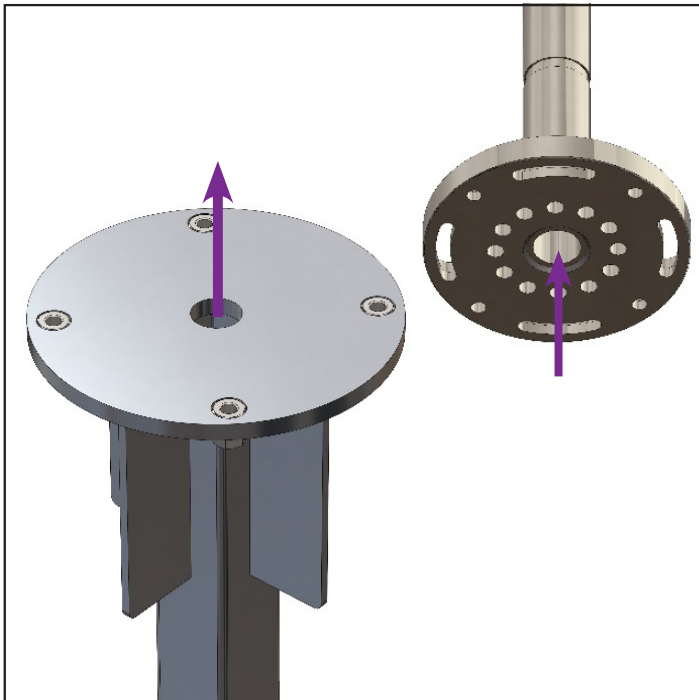

Feed the Feed Cable through the Wire Feed Hole on the Surface Plate and Spigot

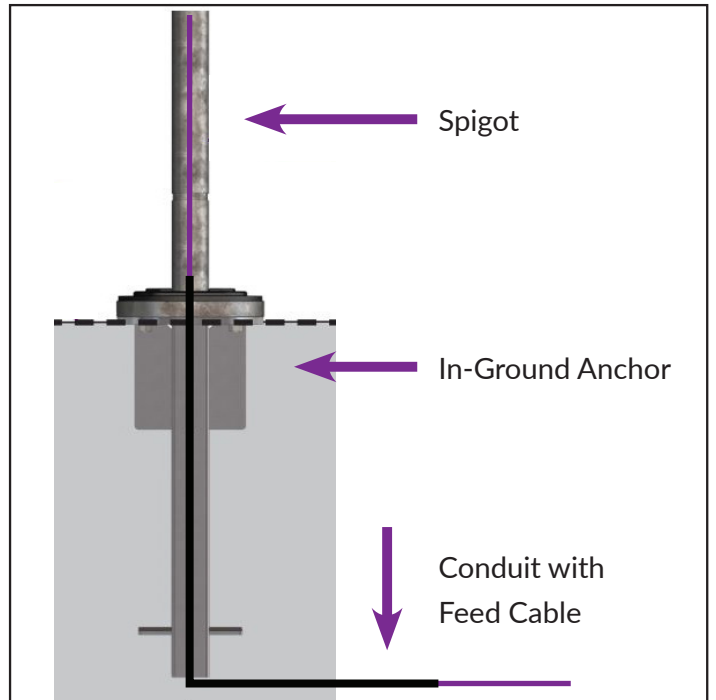

Install a conduit when you set the In-Ground Anchor to make feeding the cable easier.



- The 110V AC/DC Adaptor Input Plug should only be used with a fixed wall socket that was installed by a certified electrician.
- Please use a wall socket that is mounted in a dry and protected area or a socket that has a rain proof lid.
- Please wall mount the adaptor off the ground, ensuring that it remains dry.
- The Adaptor has an IP67 rating which makes it rain proof but not suitable for submersion into water.
- Keep in mind that the light will need to be controlled from the wall socket so access to a switch is important.
- Minimum install distance of 2 Meters and a maximum distance of 40 Meters from your umbrella.
- Please secure and conceal all wiring to ensure a reliable connection for years to come.
- All in-ground or exposed extension connections should be done using a waterproof enclosure.

Important Safety Note: Do not plug the adapter into the 110V AC mains socket until all the wiring is completed as this could cause a short circuit as you wire the umbrella.

Important

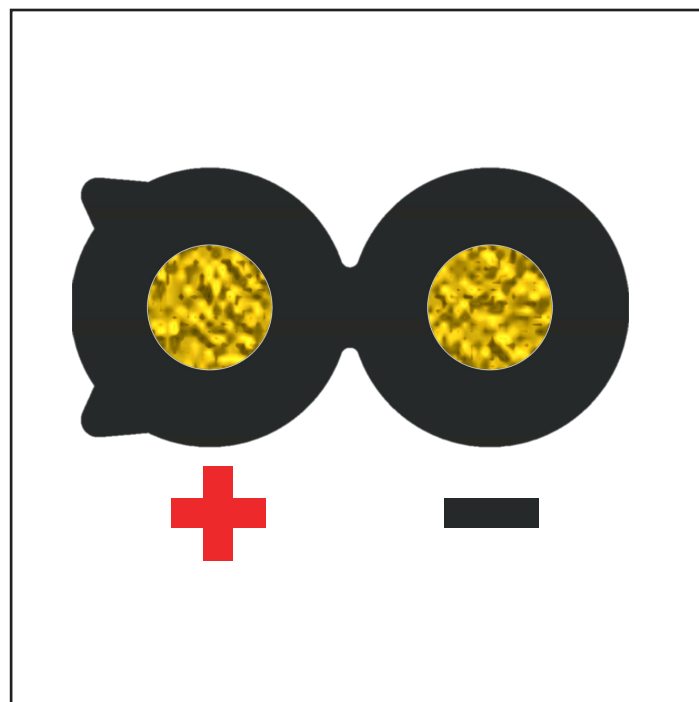

Ridged Wire is ALWAYS Positive

WARNING: Never cut or extend the 110v Mains Input Cable. Using a third-party adaptor or any other 12v DC source will void the warranty on all the umbrella LED light components.

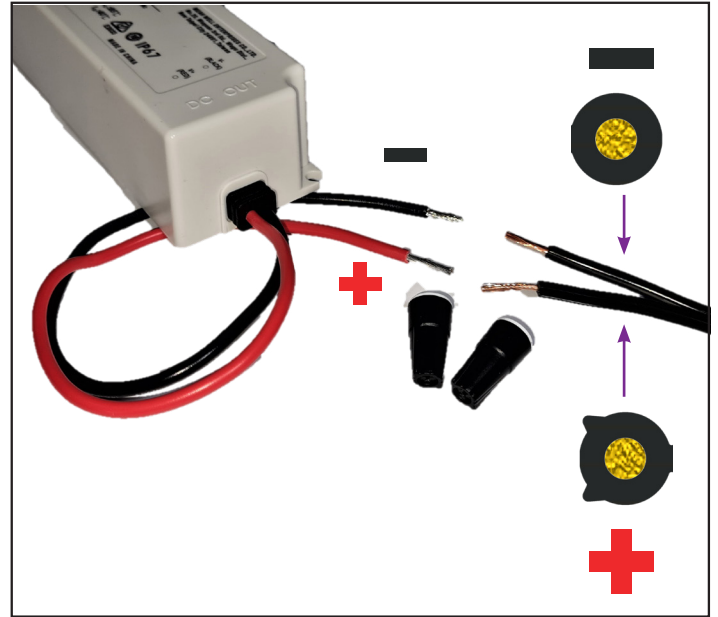
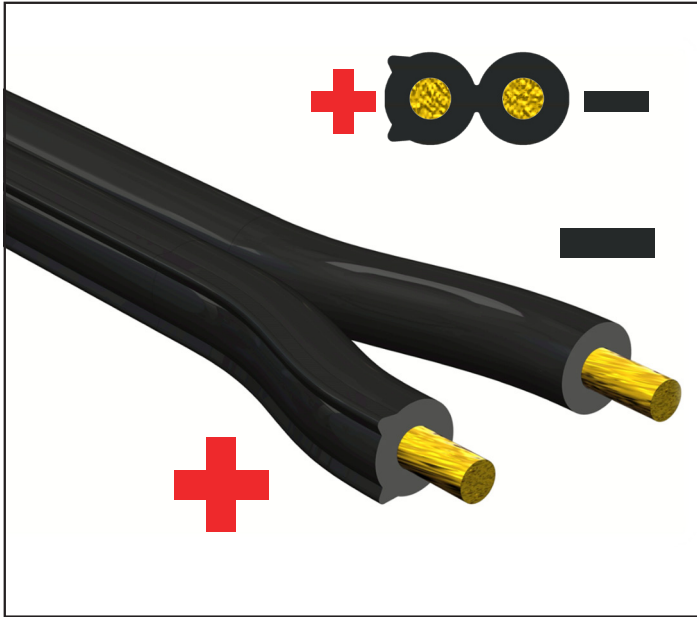

1. Strip the Feed Cable back about 15mm to expose the bare wires.

2. Twist tightly together with the 12v DC output wires from the included adaptor - please ensure to get the polarity correct.

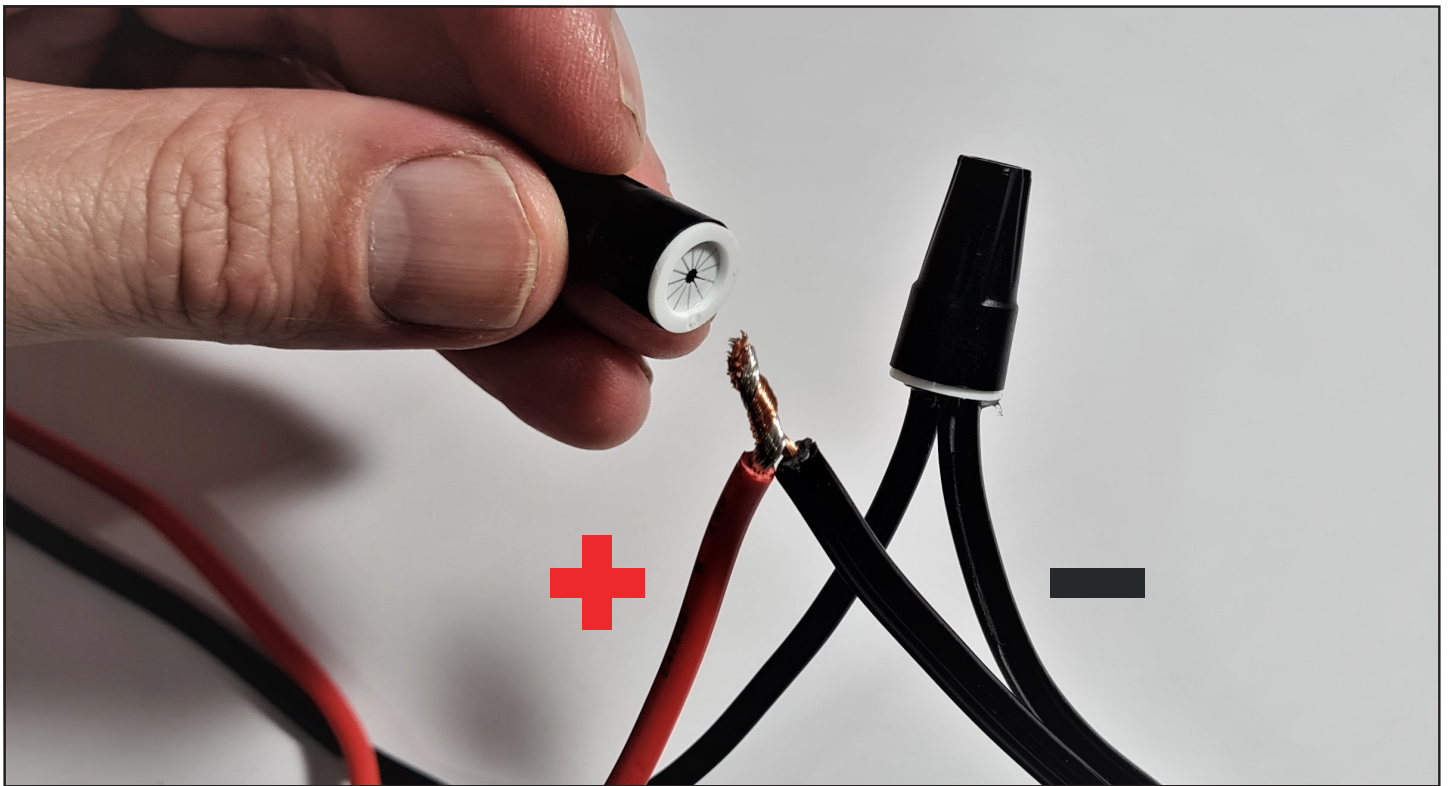

3. Tightly push the Gel Filled caps over the connection - ensure no bare wires are exposed. Secure the wires so there is no chance of the connection coming apart when the wires are pulled.

Red is always the positive wire.

Connection Point 2: 12V DC Feed cable to 9V DC Converter

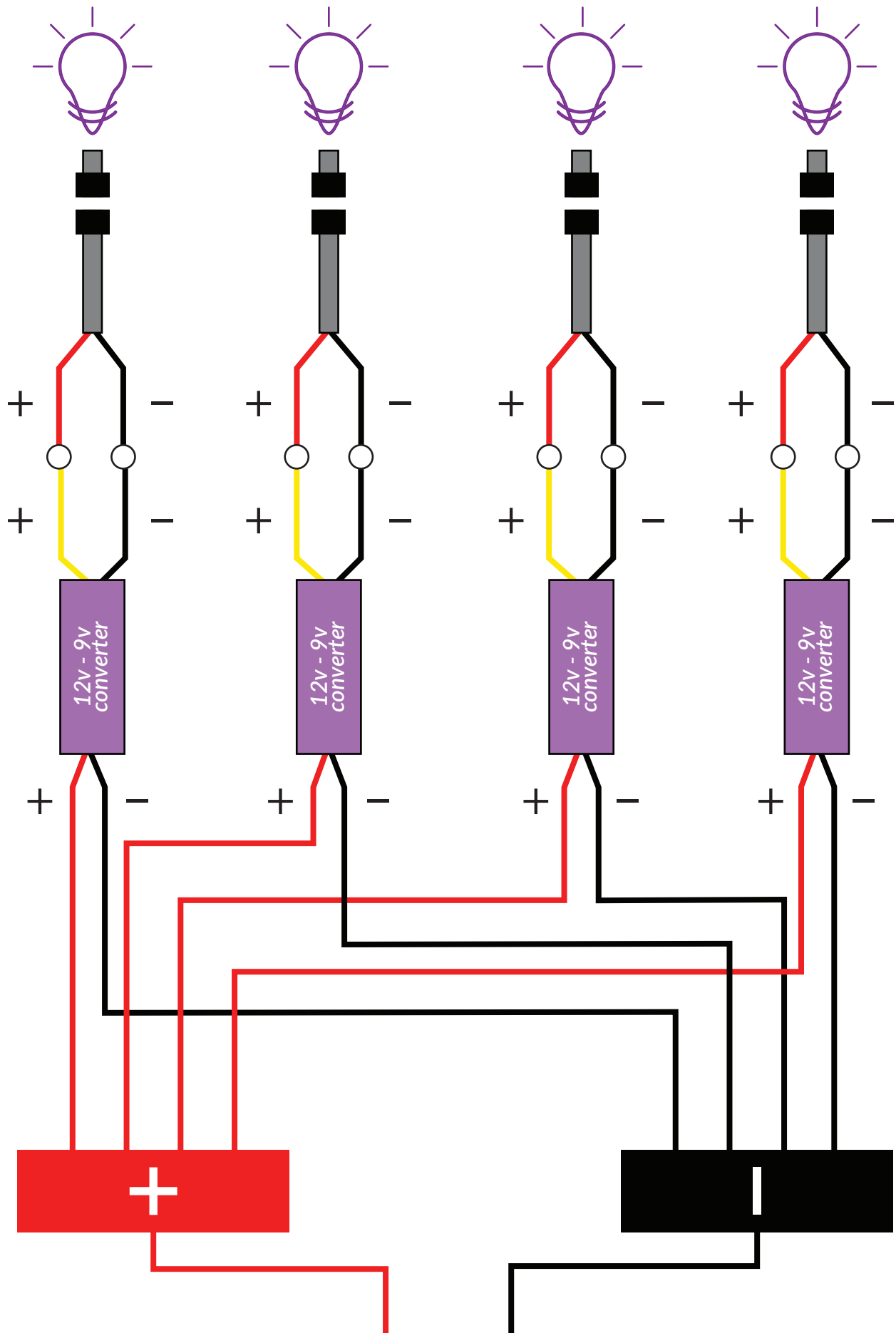

Connection Point 2: 12V DC Feed cable to 9V DC Converter



1. Remove the Top Cap from the Mast.
2. Feed the 12v Feed Cable from the Spigot (See Fig 1.) through to the top of the Mast.
3. Secure the Feed Cable with supplied Cable Ties and place Mast back on the Spigot.
4. Pull the Feed Cable taught and trim so you have 300mm of Feed Cable protruding from the top of the Mast.

All connections will be done outside the mast before being returned to the top of the Mast.

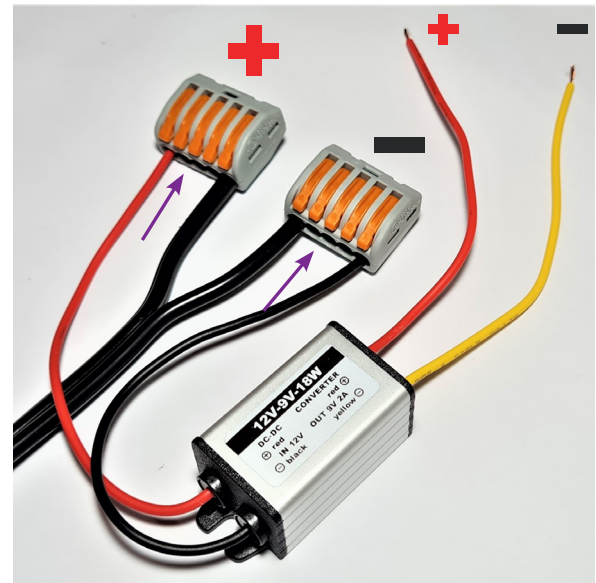
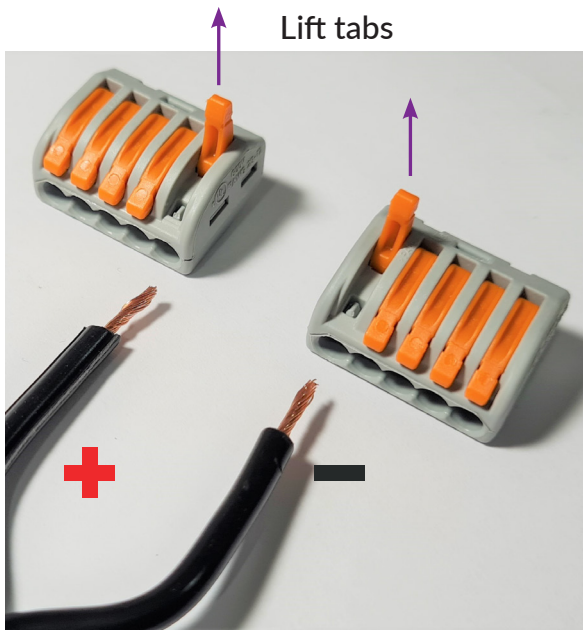
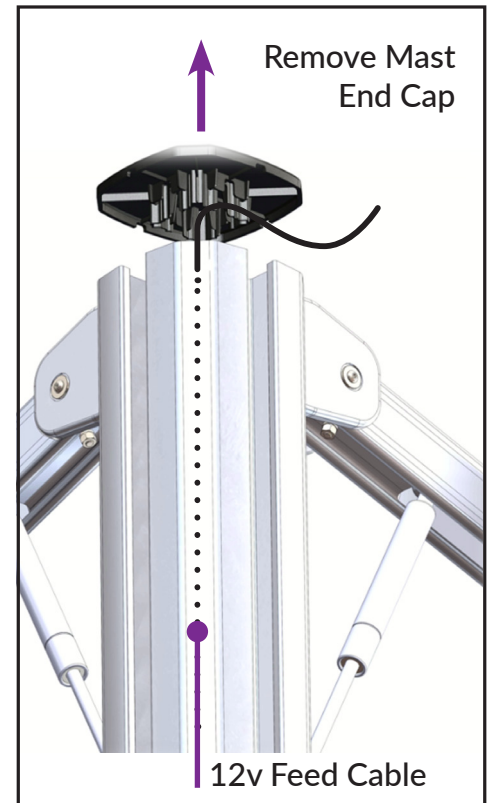
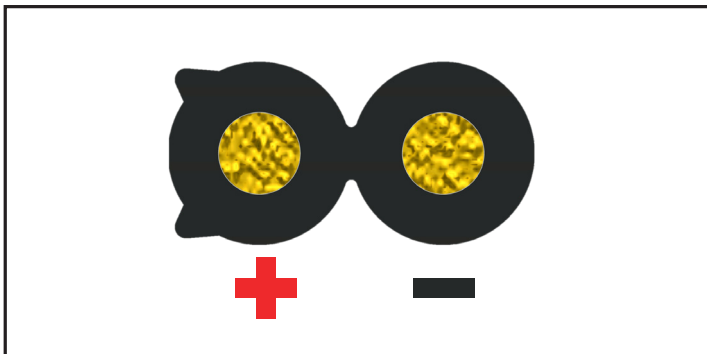

5. Strip the Feed Cable back about 10mm to expose the bare wires.
6. Roll each wire tip together. Lift the 5-Way Connector tabs and insert the Feed Cable all the way into the connector holes.
7. Strip the ends of the supplied 12v DC to 9v DC Converter back about 10mm to expose the bare wire.
8. Insert the Black and Red side of the Converter into the 5-Way Connector.
The Red Wire is positive and **MUST** be in the same 5-Way connector as the Ridged Feed Cable.
9. Repeat the process for each light you are connecting if you have more than one.
10. Double check each connector to ensure polarities and colours aren't mixed.

WARNING: Always use the 12v DC to 9v DC converters to connect to the Main Spar LED wire. **DO NOT** connect the 12V DC directly to the LED wire without using the supplied voltage converter.

Connection Point 3: 9v DC Output to Main Spar LED Wire



1. Locate the Main Spar LED Cable at the back of the Main Spar.
2. With care, pull the loose end out of the transport hole.
3. Connect the Red Wire from the 9v DC Output to the Red Wire of the LED Cable with Crimp Connector.
4. Connect the Yellow Wire from the 9v DC Output to the Black Wire of the LED Cable with Crimp Connector.
Ensure the cables are pushed all the way into the Crimp Connectors.
5. Using a pair of plyers - squeeze the coloured cap on the Crimp Connector down until it is flush.
The Connector will splice through the individual wire sleeve so there is no need to strip the wires.
6. Repeat the process for each canopy installed.

Cable location in Main Spars

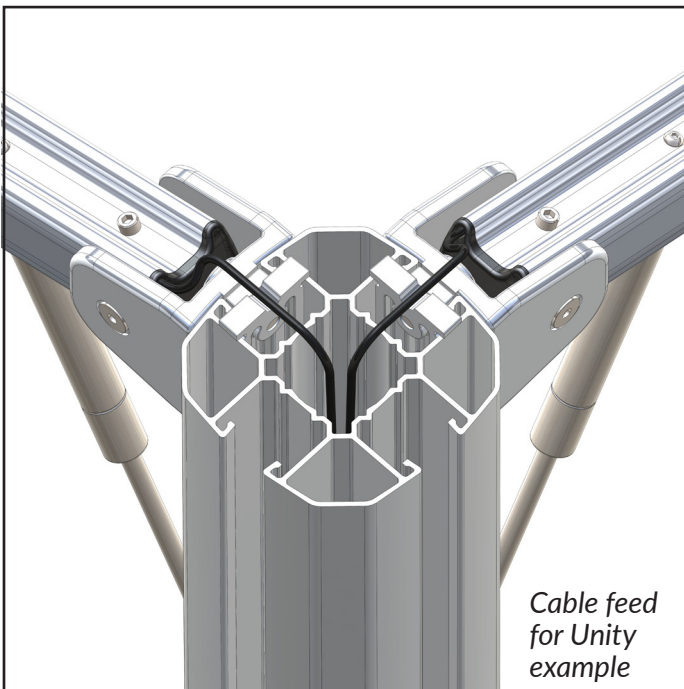

Connect the Cables with Crimp Connectors

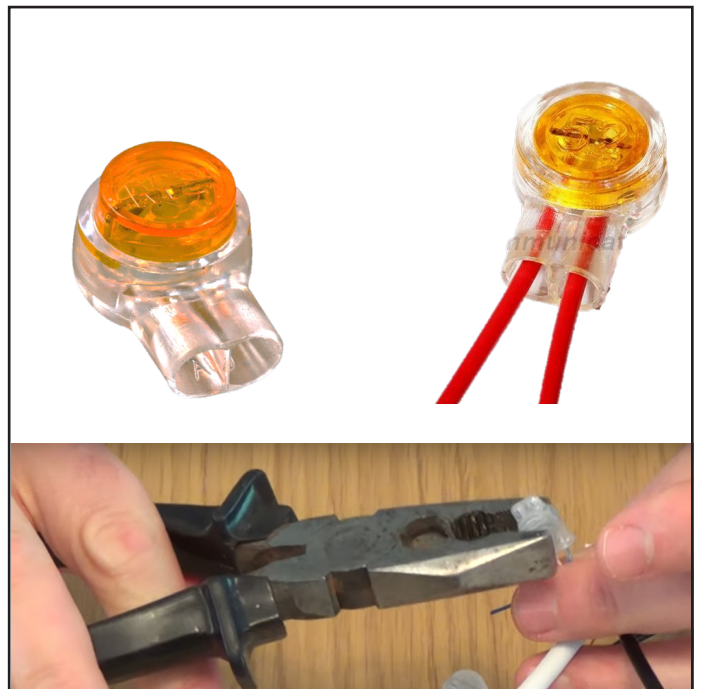

Ensure Polarity is Correct

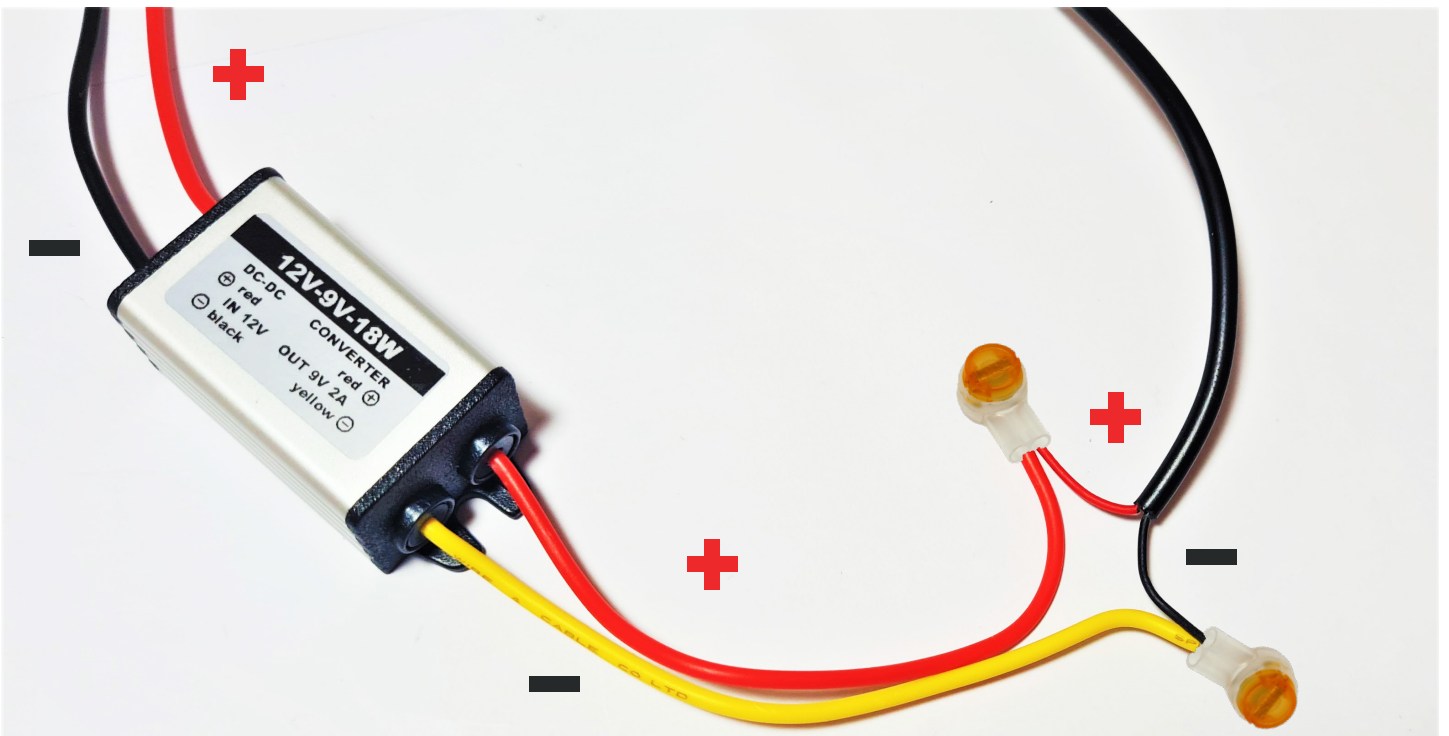

Connection Point 4: Main Spar LED Wire to LED Light



1. Plug the Main Spar LED Plug into the LED Light via the DC Plug Connector.
Ensure the connection is tight as this is a water-proof connection.
2. Push any additional slack back into the Main Spar.
3. Repeat for each Canopy installed.
4. Test all cable connections by carefully pulling on them to ensure they are secure.
5. Double check all polarity across the system.
Red wires must only be connected to red wire

Important: Connecting any third-party power source to the LED light will void the warranty.

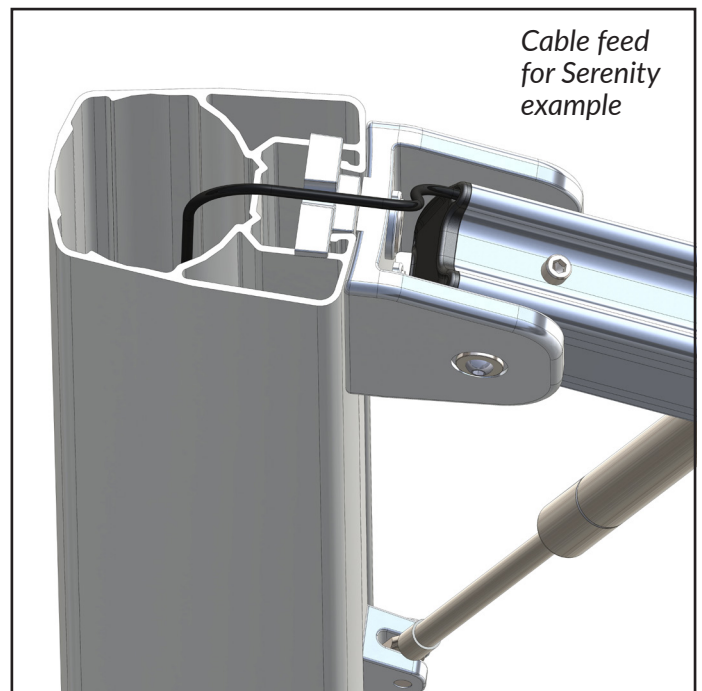
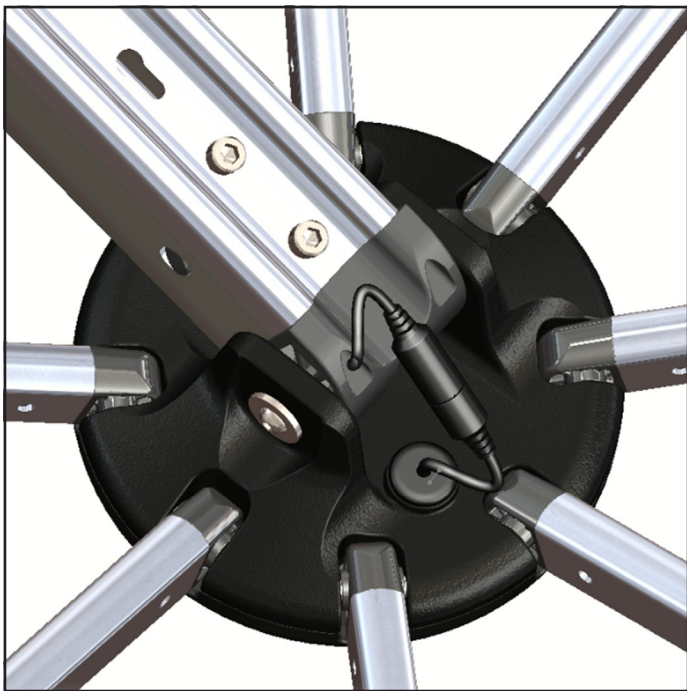

6. Return the Connection Point 3 system to the inside of the top of the Mast.
7. Double check that all connections inside the Mast are secure with no risk of bare wires touching each other inside the Mast.
Ensure the Main Spar LED Cable fits into the Groove before returning the Top Cap
8. Use the supplied Cable Ties to secure the system.
9. Replace the Top Cap on the Mast.



Fault	Suggested Solutions
The lights are not turning on when testing	<ul style="list-style-type: none"> • Double check that there is power at the mains • Double check the Main Spar cable is plugged into the LED Light • Inspect all the connections starting at connection point 1 all the way to 4 • Double Check Polarity on all connections
The lights are not turning on after previously working	<ul style="list-style-type: none"> • Double check there is power at the mains • Inspect all the connections starting at connection point 1 all the way to 4 • Check for corrosion on connection points
Not all lights are working (Shadowspec Unity)	<ul style="list-style-type: none"> • Inspect the relevant connections, starting with the connections closest to the light.
Continued issues	<ul style="list-style-type: none"> • Failing the above, remove the LED Lens cover on the Shadowhub and inspect the internal connection to the LED PCBA

Warranty and After Sales Support



- The obligation of Shadowspec under this warranty is limited to faulty manufacturing, defective materials, and faulty parts for a period of 12 months. If any parts are replaced under warranty, the warranty period will not be extended. Shadowspec shall, at its sole discretion, determine whether repair or replacement is appropriate.
- This warranty does not cover the following:
 - Damage caused by an accident, negligence, storm, wind, accumulation of water or snow, or caused by an act of God, incorrect installation.
 - Damage caused by exposure to hazardous atmospheric situations due to industry or a high slat level.
 - Damage by a third party.
 - Repair by a third party.
- This warranty does NOT cover lightning damage, or any damage caused by power surges from the mains supply. The foregoing sets out the extent of this warranty.
- Shadowspec shall not otherwise be liable or responsible for any direct, indirect, incidental, or consequential damage, costs or losses of any kind arising out of or in connection with your umbrella or components or for any delay by Shadowspec or the component manufacturer in undertaking repairs or replacement under this warranty. Except as expressly provided herein, all other warranties, representations, conditions, undertakings, rights, duties, or liabilities, whether arising by implication of law or otherwise, are hereby expressly excluded.
- If you need to enquire about a warranty claim, please either contact Shadowspec direct or the sales agent you purchased your product from.



shadowspec

umbrellas with distinction

Contact our in-house shade and outdoor specialists
for more information and advice.

AUSTRALIA

Australian Nest
Laverton North, Victoria
1800 144 155
www.shadowspec.com.au

NEW ZEALAND

Heron Base
Whangarei, Northland
0800 144 155
www.shadowspec.co.nz

UNITED STATES

North American Nest
Atlanta, Georgia
844 888 5577
www.shadowspec.com