







ASSEMBLY INSTRUCTIONS

Thank you for purchasing this quality product. Be sure to check all packing materials carefully for small parts that may have come loose inside the carton during shipment.

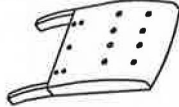
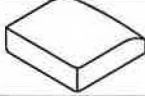
Before you start assembly: Please read all instructions carefully before beginning the assembly process. It is recommended that 2 people work together during assembly to prevent personal injury and to ensure that heavy or cumbersome parts are not damaged during the process.

CAUTION: For your safety, this product requires two people to lift.

PART LIST

No.	Description	Sketch	Quantity
A	Chair Seat EHF PART # PU3725-BACK		1PC
B	Chair Frame EHF PART # PU3725-SEAT		1PCS
C	Leg EHF PART # PU3725-FLEG		2PCS
1	Allen Bolt EHF PART # PU3725-HDWR	 5/16"*2"	9PCS
2	Spring Washer EHF PART # PU3725-HDWR	 5/16"	9PCS
3	Flat Washer EHF PART # PU3725-HDWR	 5/16"*19	9PCS
4	Allen Key EHF PART # PU3725-HDWR	 5mm	1PC

Step 1: Attach Chair Seat (A) to the Chair Frame (B) by using the Flat Washer (3), the Spring Washer (2), the Bolt (1) and tighten with the Allen Key (4).

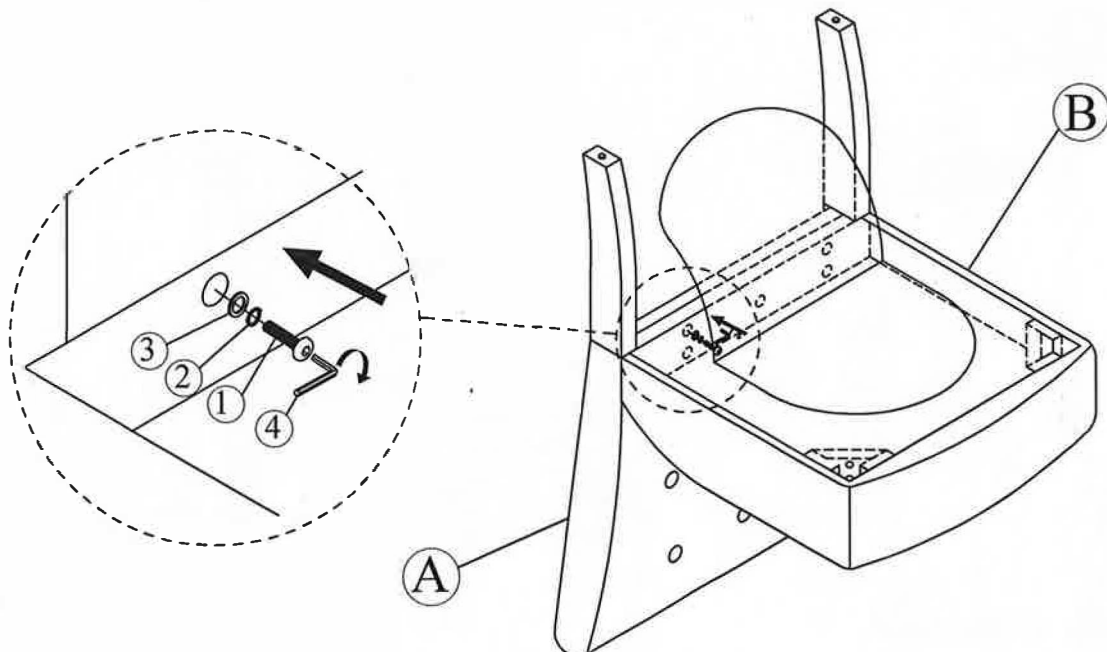

ASSEMBLY INSTRUCTIONS

Thank you for purchasing this quality product. Be sure to check all packing materials carefully for small parts that may have come loose inside the carton during shipment.

Before you start assembly: Please read all instructions carefully before beginning the assembly process. It is recommended that 2 people work together during assembly to prevent personal injury and to ensure that heavy or cumbersome parts are not damaged during the process.

CAUTION: For your safety, this product requires two people to lift.

Step 2: Attach The Leg (C) to the Chair Frame (B) using Allen Bolt (1), Spring Washer (2) and Flat Washer (3) with Allen Key (4) as above shown.

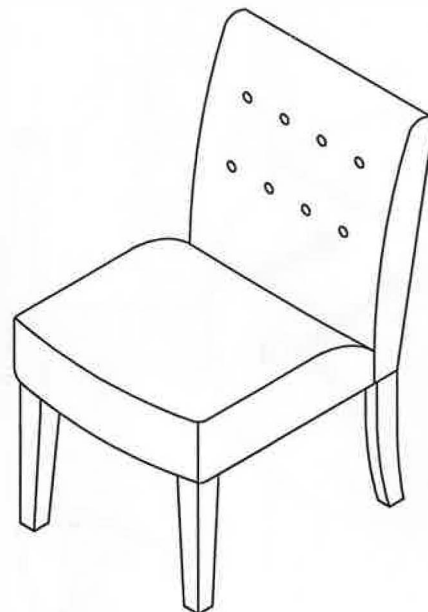
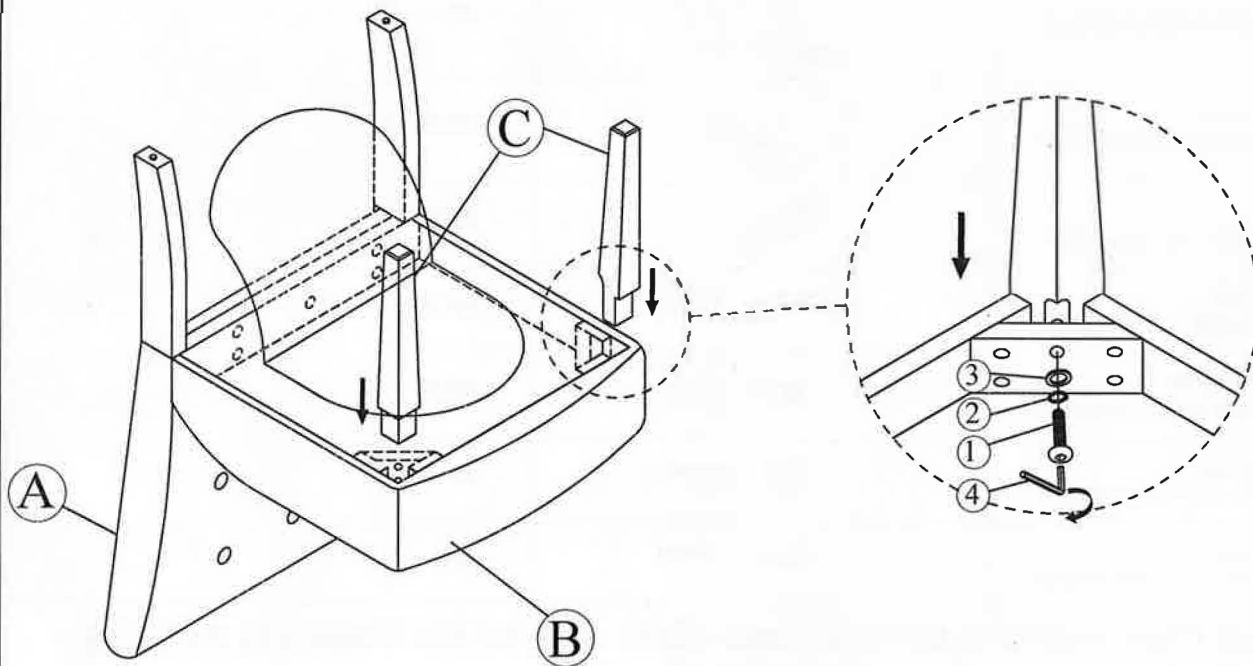

Assembly is completed.