

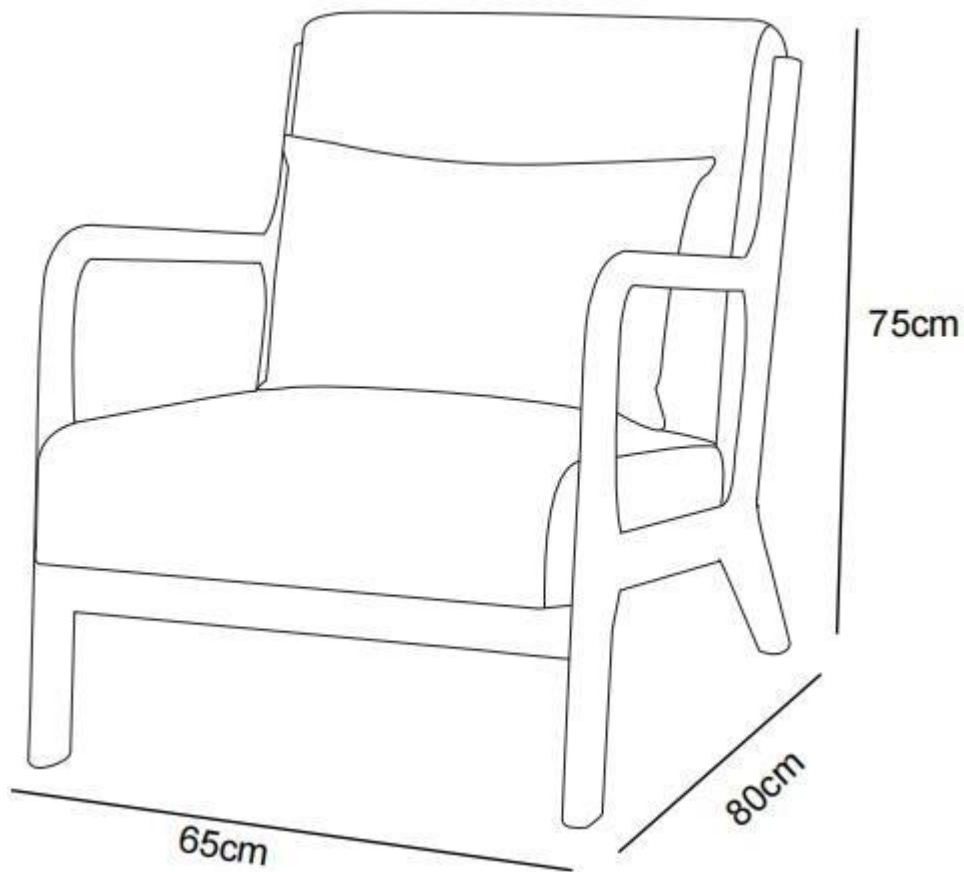

# Global Procurement & Marketing Ltd

## Nova Wooden Armchair

Assembly Instructions – Please keep for future reference

CHRNOVCRM



Dimensions	No. people	Assembly Time	OW #
Width:65cm Depth:80cm Height:75cm		20 mins (approx.)	CHRNOVCRM

### **Important**

- PLEASE READ THESE INSTRUCTIONS FULLY BEFORE STARTING ASSEMBLY
- PLEASE DO NOT THROW THE PACKAGING AWAY UNTIL YOU ARE SATISFIED WITH PURCHASE, GOODS NEED TO BE RETURNED IN ORIGINAL PACKAGING.

If you need help or have damaged or missing parts, please email [aftersales@gpmfurniture.co.uk](mailto:aftersales@gpmfurniture.co.uk)

## Safety and Care Advice

### **Important**

- PLEASE READ THESE INSTRUCTIONS FULLY BEFORE STARTING ASSEMBLY
- PLEASE DO NOT THROW THE PACKAGING AWAY UNTIL YOU ARE SATISFIED WITH PURCHASE, GOODS NEED TO BE RETURNED IN ORIGINAL PACKAGING.

- Check you have all the components and tools listed on pages 4 and 5.
- Remove all fittings from the plastic bags and separate them into their groups.
- Keep children and animals away from the work area, small parts could choke if swallowed.
- Make sure you have enough space to lay out the parts before starting.
- Do not stand or put weight on the product, this could cause damage.
- Assemble the item as close to its final position (in the same room) as possible.
- Assemble on a soft, level surface to avoid damaging the unit or your floor.
- We do not recommend the use of power drill/drivers for inserting screws, as this could damage the unit. Only use hand screwdrivers.
- Dispose of all packaging carefully and responsibly.



### **Care and Maintenance**

- Only clean using a damp cloth and mild detergent, do not use bleach or abrasive cleaners.
- From time to time check that there are no loose screws on this unit.
- This product should not be discarded with household waste. Take to your local authority waste disposal centre.

**If you are unhappy with the product and wish to return it, please follow the retailer's returns procedure.**

## Components – Chair

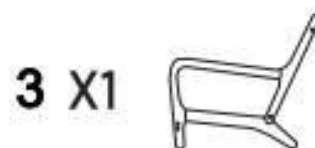
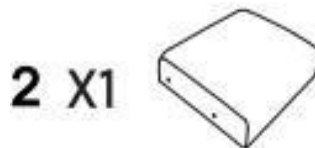
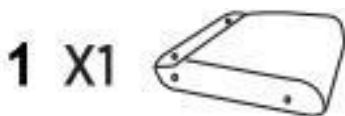

## Components – Chair







# Components - Fixings

If you have damaged or missing components,  
email: [aftersales@gpmfurniture.co.uk](mailto:aftersales@gpmfurniture.co.uk)

**Please check that you have all the components listed below before constructing your item.**

**Note:** The quantities below are the correct amount to complete the assembly. In some cases more fittings may be supplied than are required.

(A)	 Screw M8X60MM X10	(B)	 screw nut x 4	(C)	 Washer X 2	(D)	 Srew sticker x8
(E)		(F)		(G)		(H)	
(I)		(J)		(K)		(L)	
(M)		(N)		(O)		(P)	
(Q)		(R)		(S)		(T)	
(U)		(V)		(W)		(X)	

## Tools Supplied



**Ruler** – Use this to measure your screws (mm)

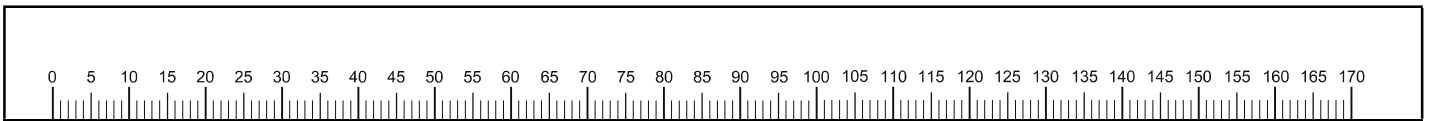

**Important** – Please read these instructions fully before starting assembly

If you need help or have damaged or missing parts, please email [aftersales@gpmfurniture.co.uk](mailto:aftersales@gpmfurniture.co.uk)

# Assembly Instructions

If you have damaged or missing components,  
email: [aftersales@gpmfurniture.co.uk](mailto:aftersales@gpmfurniture.co.uk)

## Step 1

Turn over the seat, using the hex key, attach the seat to the backrest likebelow.

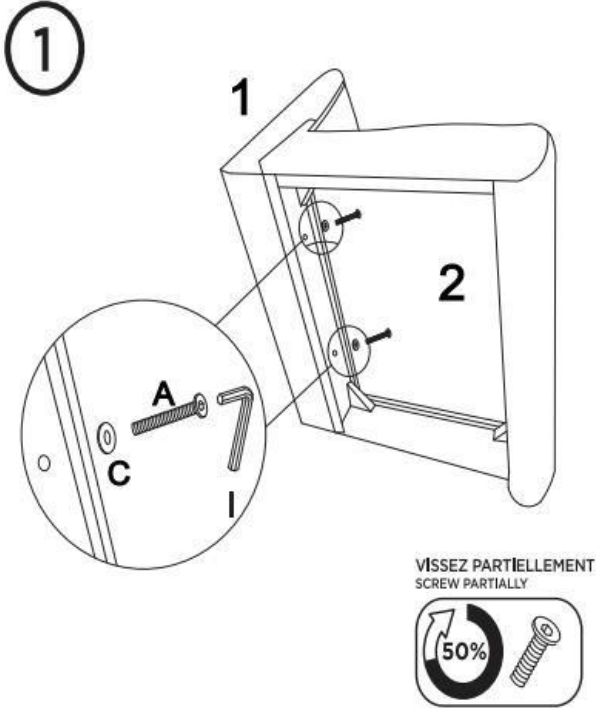

## Step 2

Put the screw nut into the holes on the seat bar.

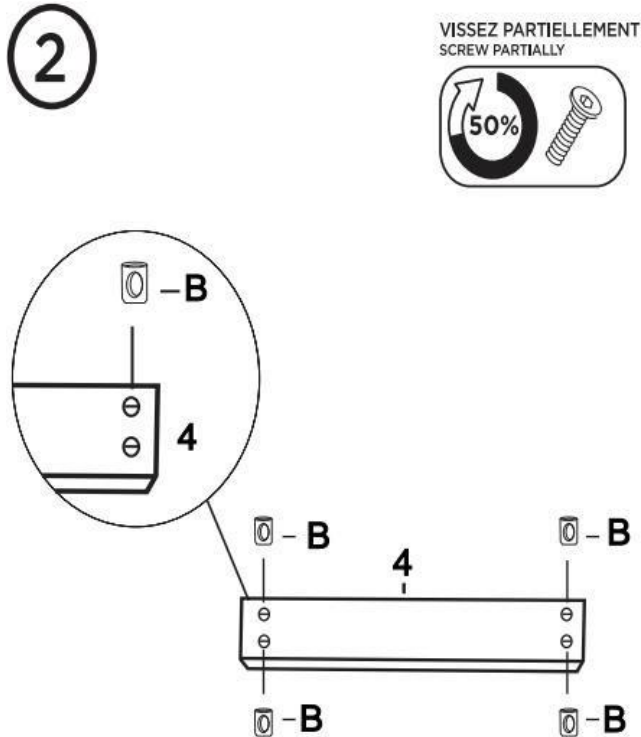

Step 3

Using the hex key, attach the frames to the seat bar.

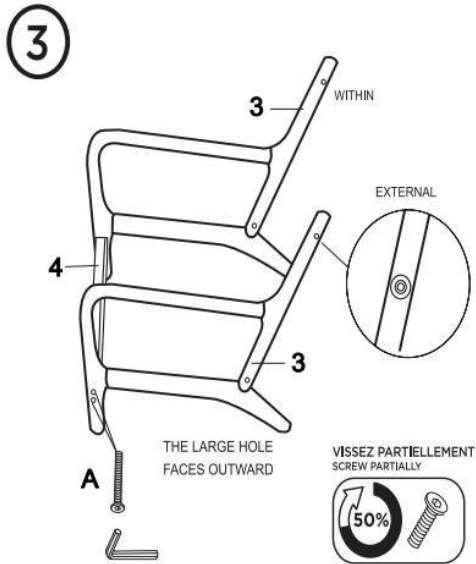

Step 4

Using the hex key, attach the seat and backrest.

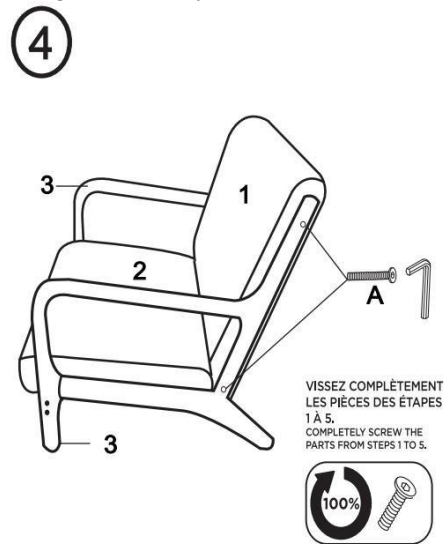

Step 5

Stick the screw stickers on the screws.

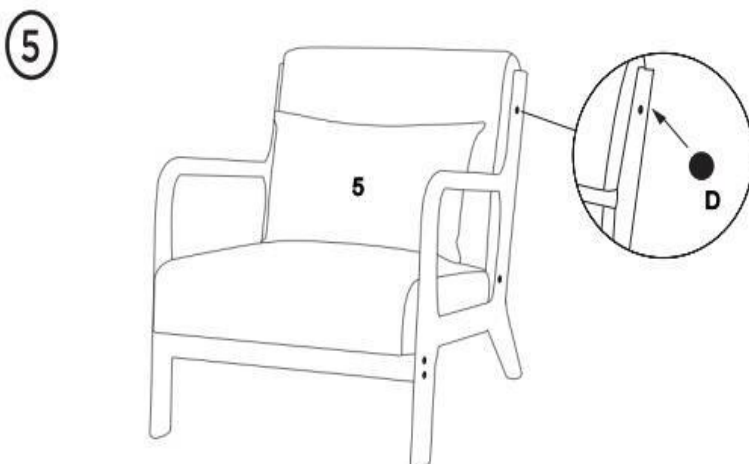

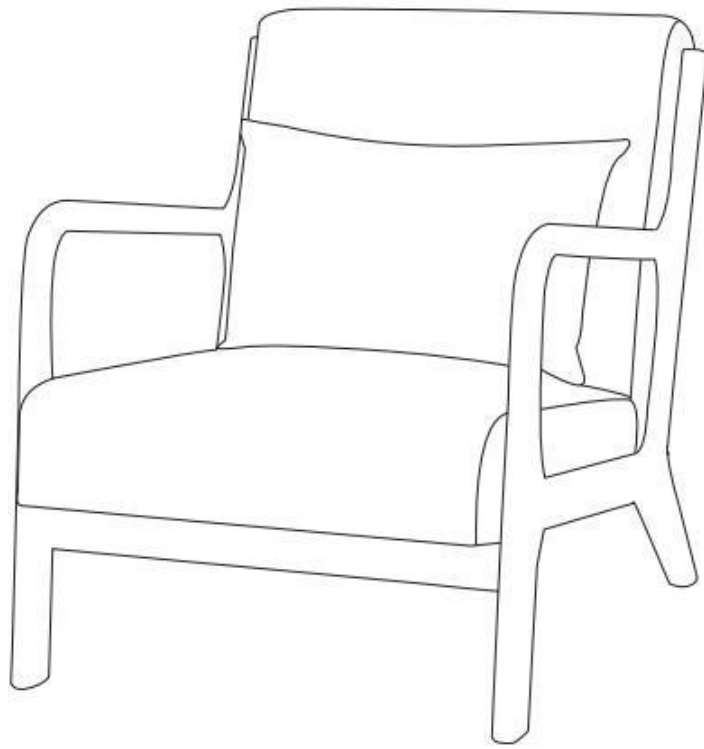

**Assembly is complete**