

Vanity Desk

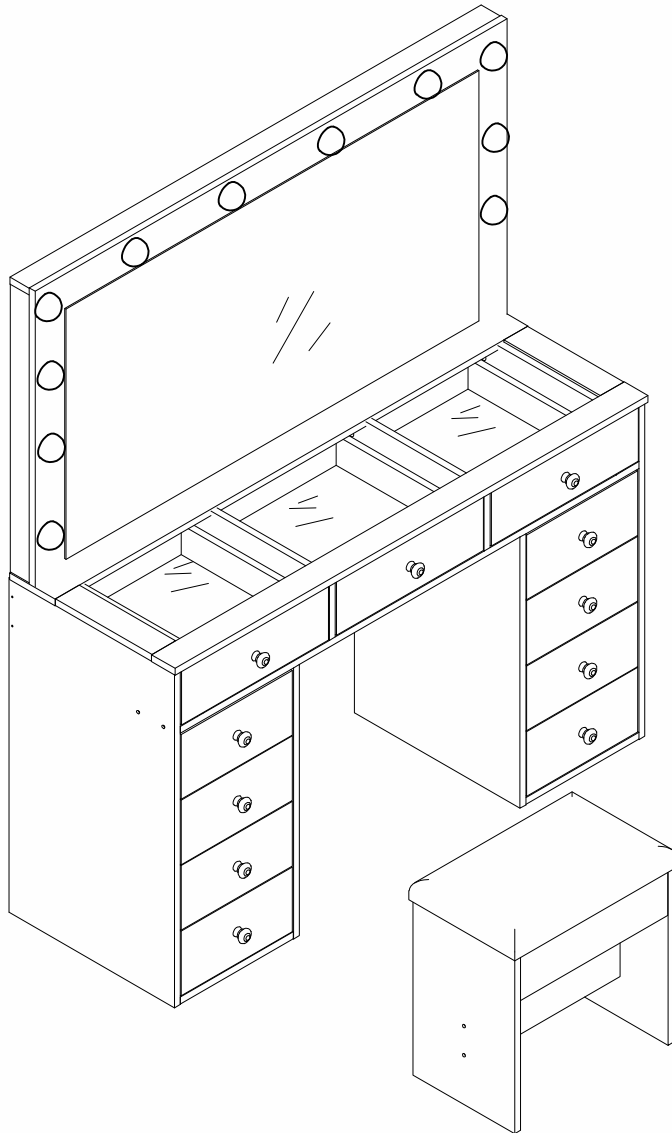

Suggestion: To make the installation process easier and faster, we recommend that two people work together to install the **Vanity Desk**

EN

General Guidelines

- Please read the following instructions carefully and use the product accordingly.
- Please keep this manual and hand it over when you transfer the product.
- This summary may not include every detail of all variations and considered steps. Please contact us when further information and help are needed.

Notes

- Product is intended for indoor use only. It must be assembled and used according to the instructions. The seller does not accept any responsibility for damage or injury resulting from improper assembly or use.
- Please avoid long-term exposure to humid environment to prevent mildew.
- During assembly, align all screws with the corresponding pre-drilled holes first and then tighten them one by one.
- Inspect the screws regularly. Screws may become loose during long-term use. If necessary, retighten them to ensure stability and security.

Warnings

- Children are not allowed to assemble the product. During assembly, keep any small part out of reach of children as they may be fatal if swallowed or inhaled.
- Children are not allowed to stand, climb or play on the product to avoid serious bodily injury by the toppling.
- Keep plastic packing bags out of reach of children to avoid any potential danger, such as suffocation.
- Avoid sharp objects and corrosive chemicals to prevent damage to the product or bodily injury.

DE

Einleitung

- Bitte lesen Sie die folgende Anleitung aufmerksam durch und verwenden Sie das Produkt sachgemäß.
- Bewahren Sie diese Anleitung gut auf und händigen Sie sie bei Weitergabe des Produkts an Dritte ebenfalls mit aus.
- Aus Gründen der Übersicht können nicht alle Details zu allen Varianten und denkbaren Montagen beschrieben werden. Wenn Sie weitere Informationen und Hilfe benötigen, kontaktieren Sie uns bitte.

Hinweise

- Dieses Produkt ist nur für den Gebrauch in Innenräumen vorgesehen. Eine andere Verwendung als beschrieben, oder eine Veränderung/ein Umbau des Produkts ist nicht erlaubt und kann zu Verletzungen und/oder Beschädigungen des Produkts führen. Der Händler übernimmt keine Haftung für Schäden, die durch unsachgemäßen Gebrauch oder falsche Montage entstanden sind.
- Halten Sie das Produkt nicht langfristig in einer feuchten Umgebung, um Schimmel zu vermeiden.
- Ziehen Sie die Schrauben bitte zuerst nicht an. Nachdem Sie alle Schrauben eingesetzt haben, schrauben Sie sie erst vorsichtig fest.
- Prüfen Sie regelmäßig den festen Sitz der Schrauben und Verbindungen, falls notwendig nachziehen.

Warnhinweise

- Halten Sie Kinder bei der Montage fern, da Kleinteile bei Verschlucken oder Einatmen tödlich sein können.
- Um mögliche Körperverletzungen zu vermeiden, ist es Kindern verboten, auf diesem Produkt zu klettern oder damit zu spielen.
- Schützen Sie Ihre Kinder von Verpackungsteile wie Folien oder Plastikbeutel fern, da Verpackungsteile oft nicht erkennbare Gefahren bergen (z. B. Erstickengefahr).
- Halten Sie spitze Gegenstände und ätzende Chemikalien vom Produkt fern, da diese die Oberfläche beschädigen können.

FR

Introduction

- Lisez attentivement ces instructions et utilisez votre produit d'après ce mode d'emploi.
- Conservez ces instructions. Si vous souhaitez offrir ce produit à un tiers, joignez obligatoirement ce mode d'emploi.
- Pour des raisons de clarté, les détails concernant chaque variante ou montage envisageable ne peuvent être tous décrits. Si vous souhaitez obtenir plus d'informations ou si vous rencontrez certains problèmes non traités de manière détaillée dans ces instructions, veuillez nous contacter.

Notes

- Ce produit est conçu pour une utilisation à l'intérieur. Le produit doit être monté et utilisé d'après ce mode d'emploi. Les utilisations qui ne correspondent pas à la description ci-dessus ou les modifications de l'article ne sont pas autorisées. Le vendeur ne prend aucune responsabilité des dommages causés par un montage incorrect ou une utilisation non conforme.
- Évitez de placer le produit dans un environnement humide pendant une longue durée car peut provoquer de la moisissure.

- Lors du montage, veuillez bien positionner et régler toutes les vis et les écrous, ensuite effectuer un serrage progressif de l'ensemble des vis.
- Il est conseillé de vérifier régulièrement les vis qui pourraient se desserrer progressivement pendant l'utilisation, ce qui risque de provoquer des dommages causés par un renversement du produit. Veuillez donc à vous assurer que les vis sont bien serrées.

Avertissements

- Il est interdit aux enfants de participer à l'assemblage du produit car il comprend de nombreuses petites pièces et l'aspiration ou l'ingestion de ces pièces présente un risque mortel.
- Ne pas laissez les enfants monter ou jouer sur le produit pour éviter des blessures causés par le renversement du produit.
- Pour éviter le danger inattendu (ex. l'étouffement), gardez toutes pièces et l'emballage (films, sac plastiques, polystyrènes, etc.) loin des enfants.
- Éloignez les objets pointus ou corrosifs du produit pour éviter les dommages possibles.

IT

Linee guida generali

- Si prega di leggere attentamente le seguenti istruzioni e usare il prodotto in modo opportuno.
- Si prega di conservare questo manuale e consegnarlo quando il prodotto cambia proprietario.
- Questo riassunto potrebbe non includere ogni dettaglio di tutte le variazioni e le fasi considerate. Contattaci se hai bisogno di ulteriori informazioni e assistenza.

Note

- Il prodotto è inteso esclusivamente per uso interno. Deve essere assemblato e usato come descritto nelle istruzioni. Il rivenditore non accetta alcuna responsabilità per danni o infortuni risultanti da assemblaggio o uso improprio.
- Si prega di evitare esposizione prolungata a ambienti umidi per prevenire la formazione di muffa.
- Durante l'assemblaggio, allineare tutte le viti con i fori corrispondenti, quindi stringerle una ad una.
- Controllare regolarmente le viti. Potrebbero allentarsi dopo lunghi periodi d'uso. Se necessario, stringerle nuovamente per garantire stabilità e sicurezza.

Avvertenze

- I bambini non possono assemblare il prodotto. Durante l'assemblaggio, tenere le parti di piccole dimensioni fuori dalla portata dei bambini, potrebbero essere fatali se ingerite o inalate.
- Impedire ai bambini di salire in piedi, arrampicarsi o giocare sul prodotto per evitare infortuni gravi causati dalla caduta.
- Tenere le borse di plastica dell'imballaggio fuori dalla portata dei bambini per evitare qualsiasi potenziale rischio, come il soffocamento.
- Fare attenzione a oggetti appuntiti e sostanze corrosive per prevenire danni e infortuni.

ES

Acerca del manual

- Por favor, lea detenidamente las instrucciones y respete los debidos usos del producto.
- Por favor, conserve bien este manual y en caso de cesión, no omita entregarlo junto al producto.
- Este manual podría no incluir todos los detalles de cada paso del montaje. Si necesita ayuda o información adicional, póngase en contacto con nosotros.





Notas

- Este producto está diseñado para uso interior. Ha de montarse y utilizarse el producto paso a paso siguiendo las instrucciones. De lo contrario, el vendedor no asume ninguna responsabilidad por los daños causados por el montaje y usos inadecuados.
- No coloque el producto en un ambiente húmedo durante un largo período de tiempo para evitar causar moho.
- Durante el montaje, por favor, no apriete completamente ningún tornillo, después de completar la instalación, apriete fuertemente todos los tornillos.
- Inspeccione regularmente los tornillos. Durante el uso, los tornillos tal vez se vayan soltando, causarán daños por la caída del producto, por eso asegure que todos los tornillos estén apretados.

Advertencias

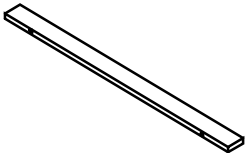
- Debido a múltiples tornillos y otras piezas pequeñas, no permita que se acerquen los niños por el riesgo de asfixia producido por tragar alguna pieza.
- No permita que el niño se suba o juegue con el producto para prevenir las lesiones causadas por la caída del producto.
- Guarde la bolsa de plástico fuera del alcance de los niños para evitar el peligro de asfixia.
- Mantenga el producto alejado de los objetos afilados y sustancias químicas agresivas.

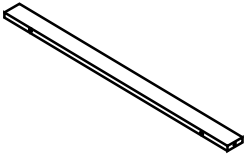
Accessories list

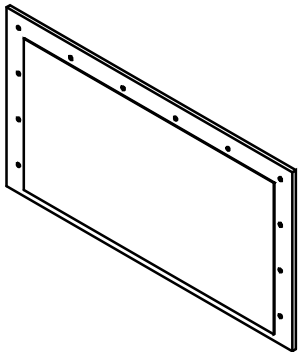
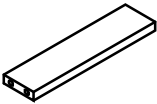
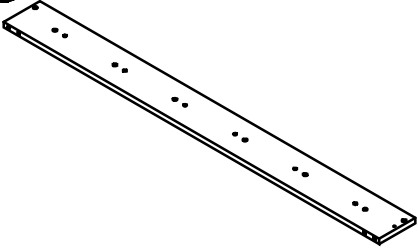
<p>1 X1</p> 	<p>2 X1</p> 
<p>3 X1</p> 	<p>4 X1</p> 
<p>5 X1</p> 	<p>6 X1</p> 
<p>7 X2</p> 	<p>8 X1</p> 

Accessories list

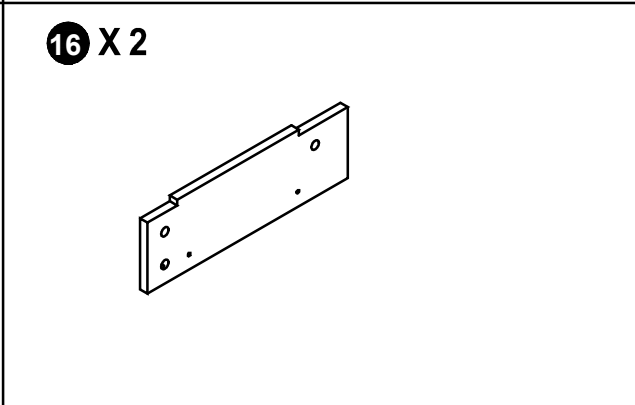
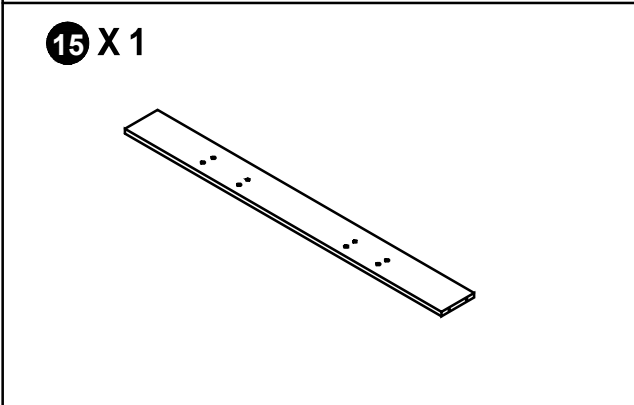
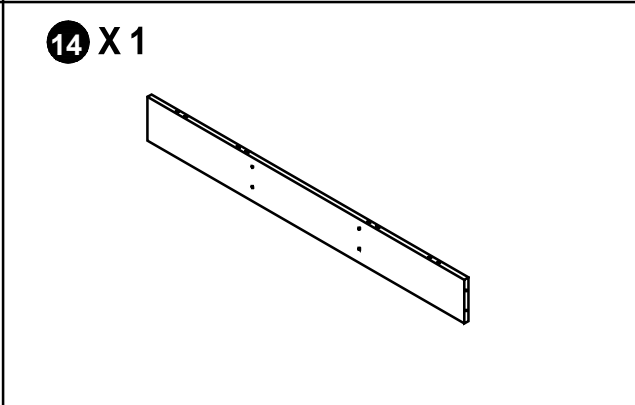
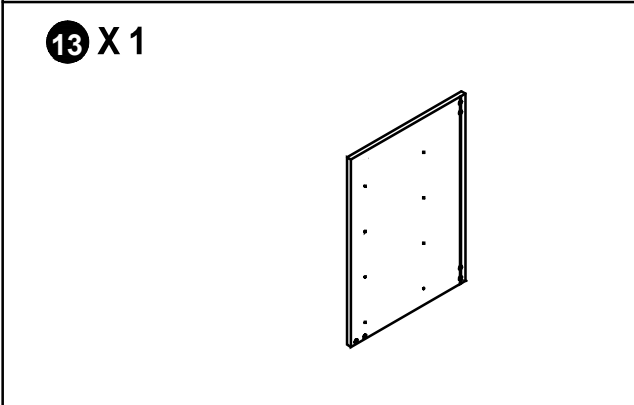
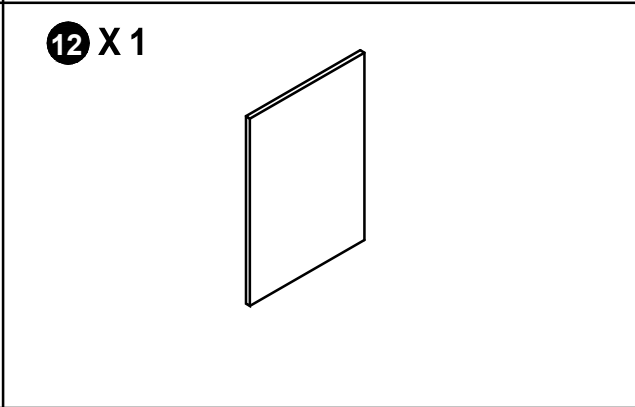
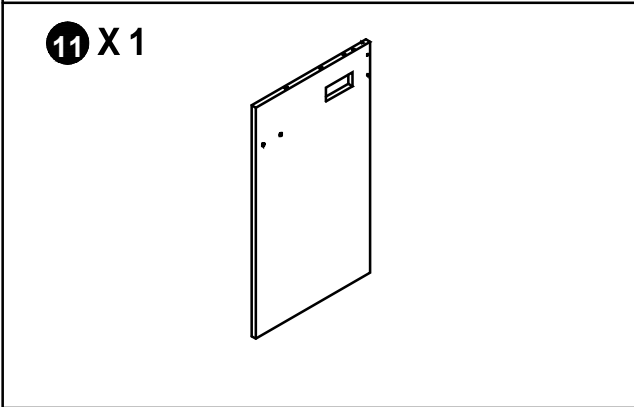
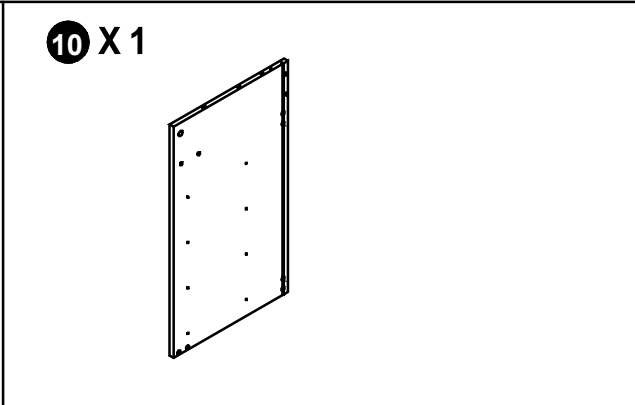
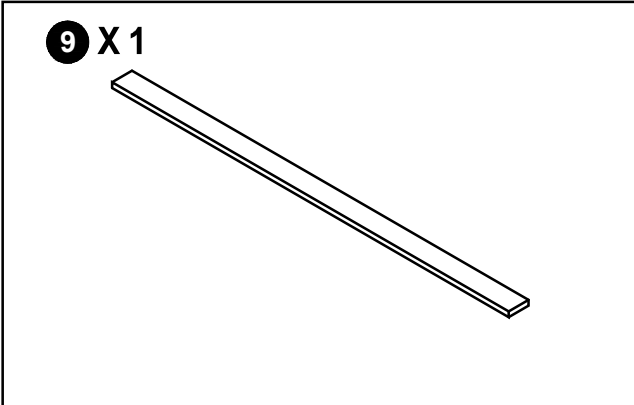



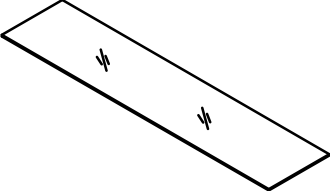
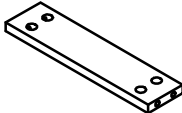
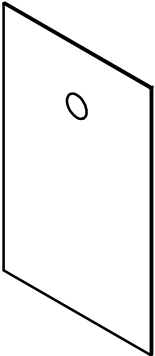
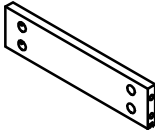
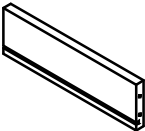
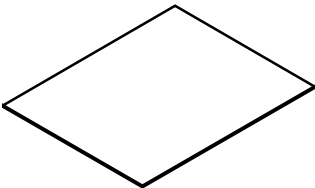
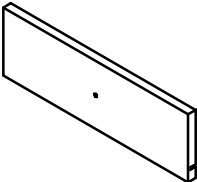
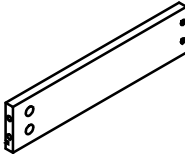



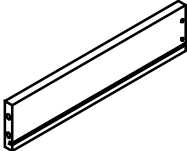
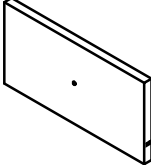
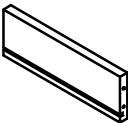
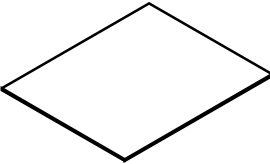
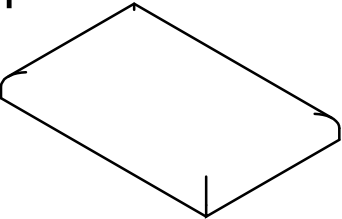
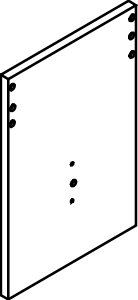
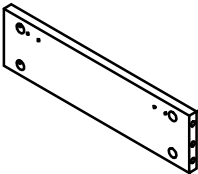
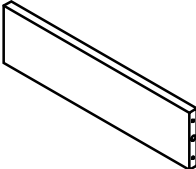

Accessories list

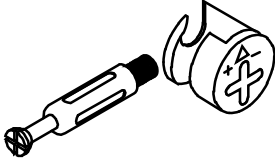
<p>17 X 1</p> 	<p>18 X 2</p> 
<p>19 X 2</p> 	<p>20 X 4</p> 
<p>21 X 3</p> 	<p>22 X 3</p> 
<p>23 X 3</p> 	<p>24 X 11</p> 

Accessories list

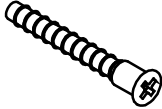
<p>25 X 11</p> 	<p>26 X 8</p> 
<p>27 X 8</p> 	<p>28 X 8</p> 
<p>29 X 1</p> 	<p>30 X 2</p> 
<p>31 X 2</p> 	<p>32 X 1</p> 

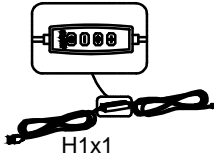
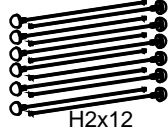
Accessories list

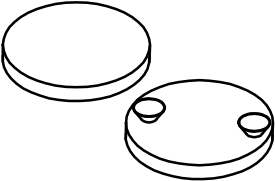
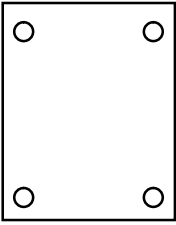
<p>A X 44</p> 	<p>B X 63</p> 
<p>C X 132</p>  <p>3.5x12</p>	<p>D X 4</p>  <p>3.5x14</p>
<p>E X 44</p>  <p>3.5x35</p>	<p>F X 24</p> 
<p>G X 34</p>  <p>8x40</p>	<p>H X 1</p>  <p>H1x1</p>  <p>H2x12</p>  <p>H3x12</p>
<p>I X 1</p> 	<p>J X 4</p> 

Accessories list

K X1

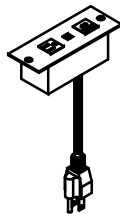

L X1



M X4



N X11

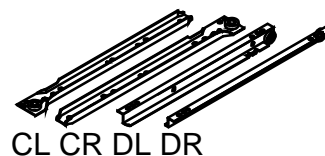

O X11

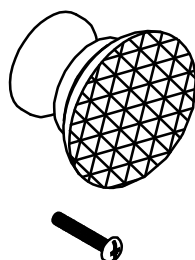

P X4

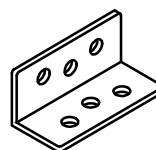

Q X16



R X1

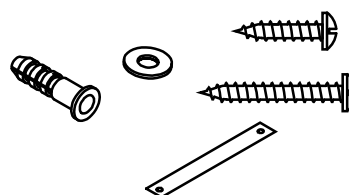

S X4

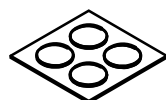

INSTALLATION INSTRUCTIONS

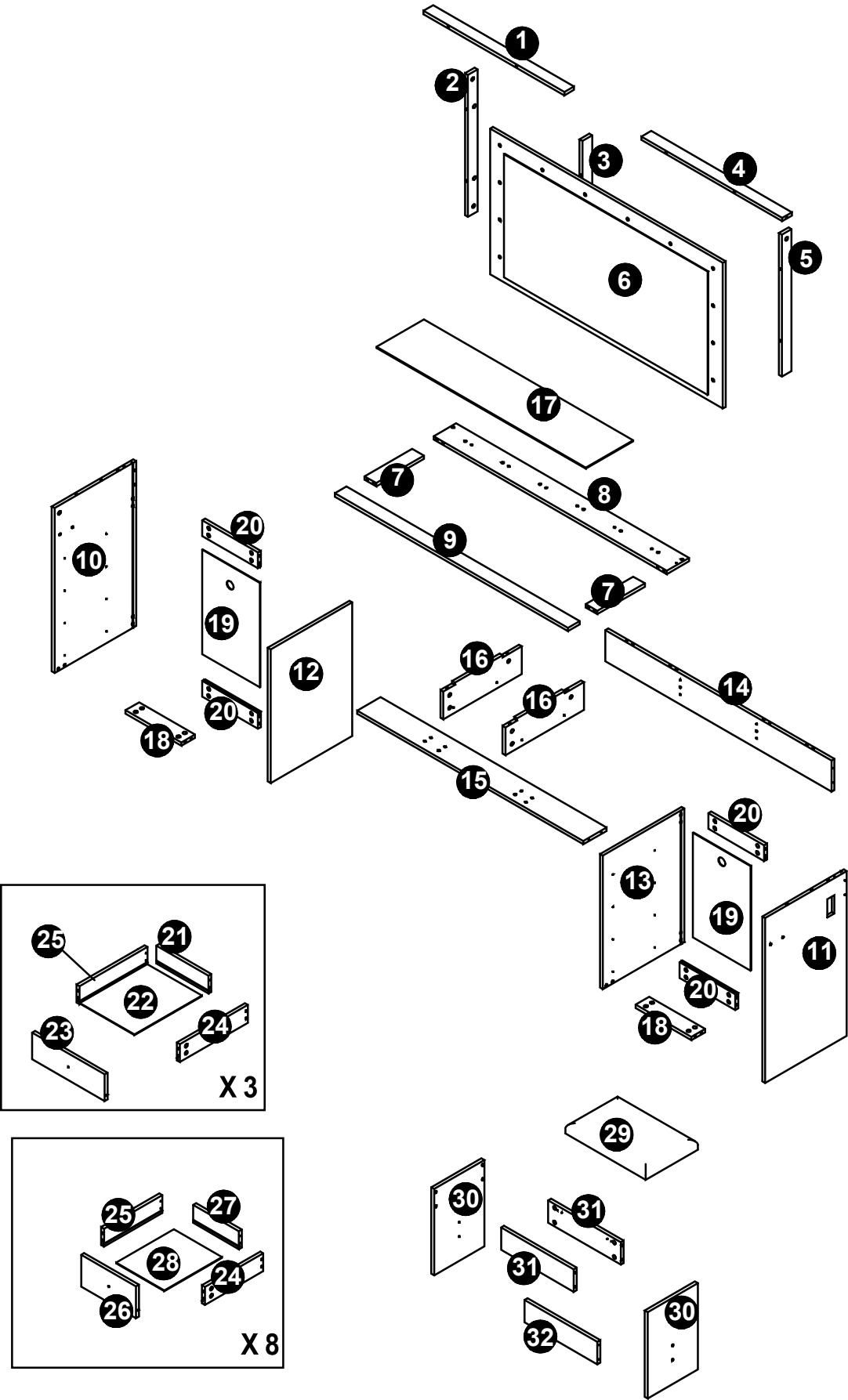

INSTALLATION INSTRUCTIONS

STEP 1

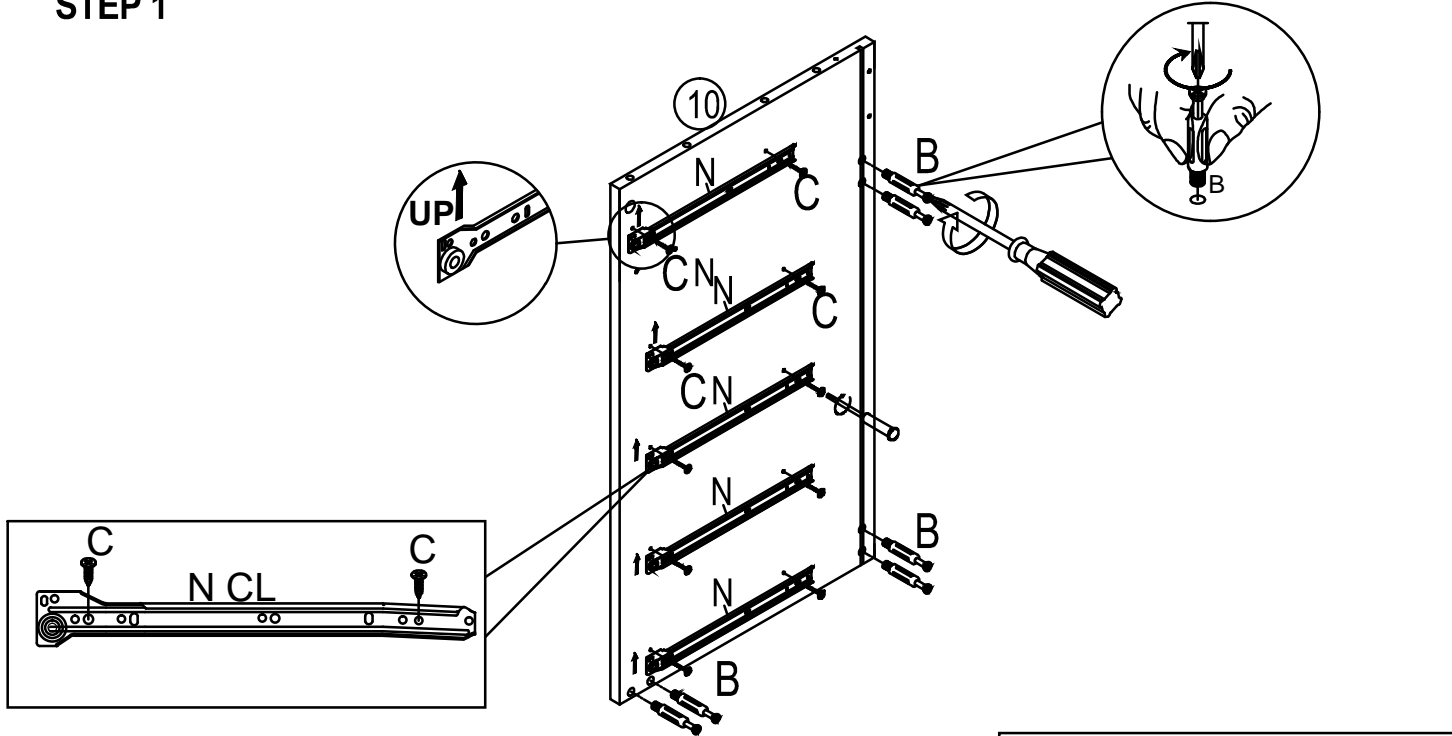

B		x6
C		x10
N		x5

STEP 2

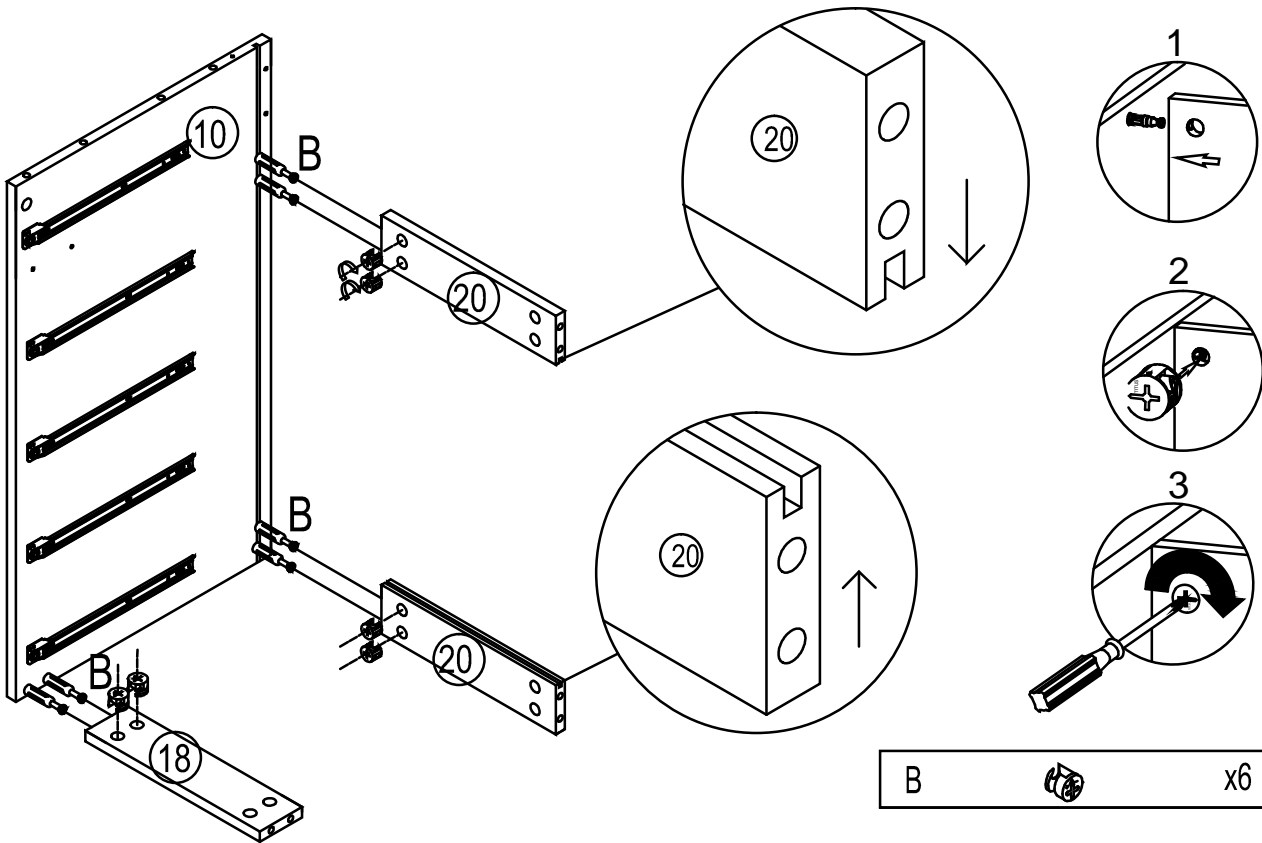

B		x6
---	--	----

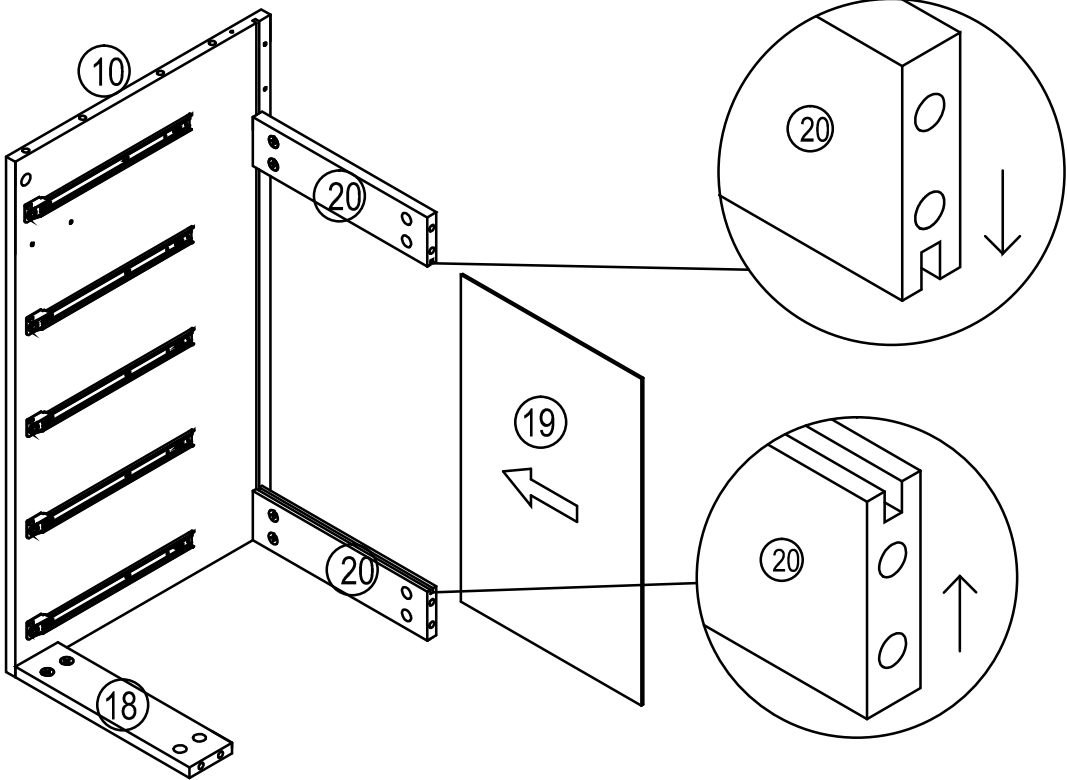

INSTALLATION INSTRUCTIONS

STEP 3

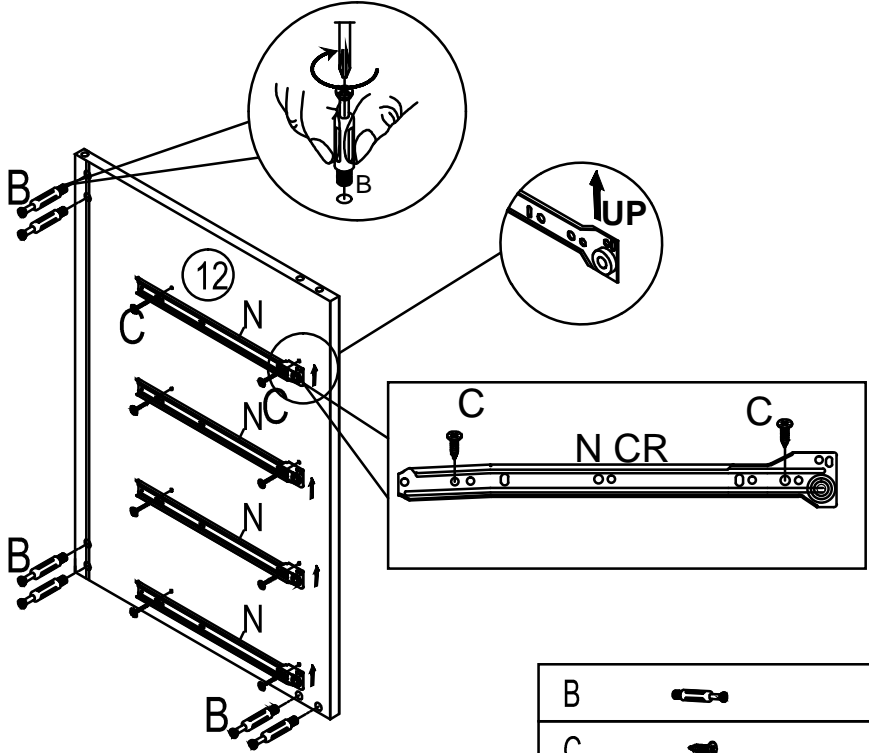

STEP 4

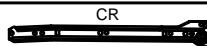

B		x6
C		x8
N		x4

INSTALLATION INSTRUCTIONS

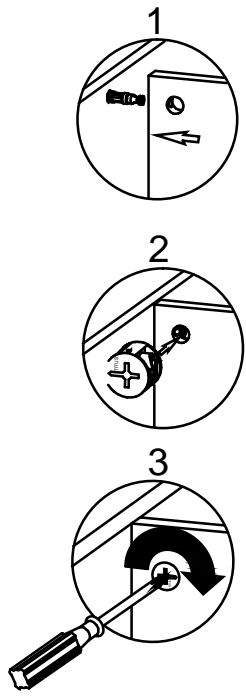
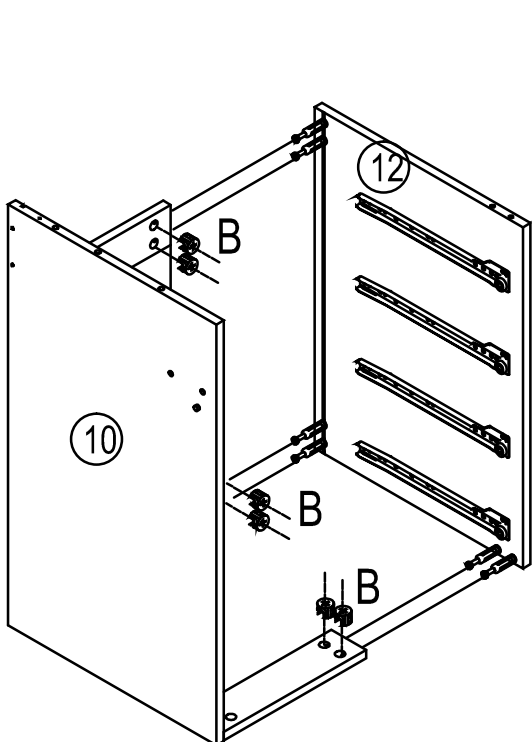

STEP 5

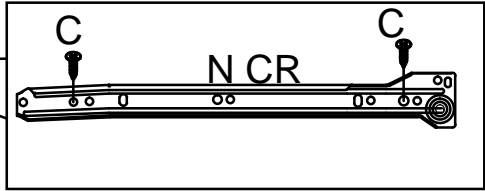
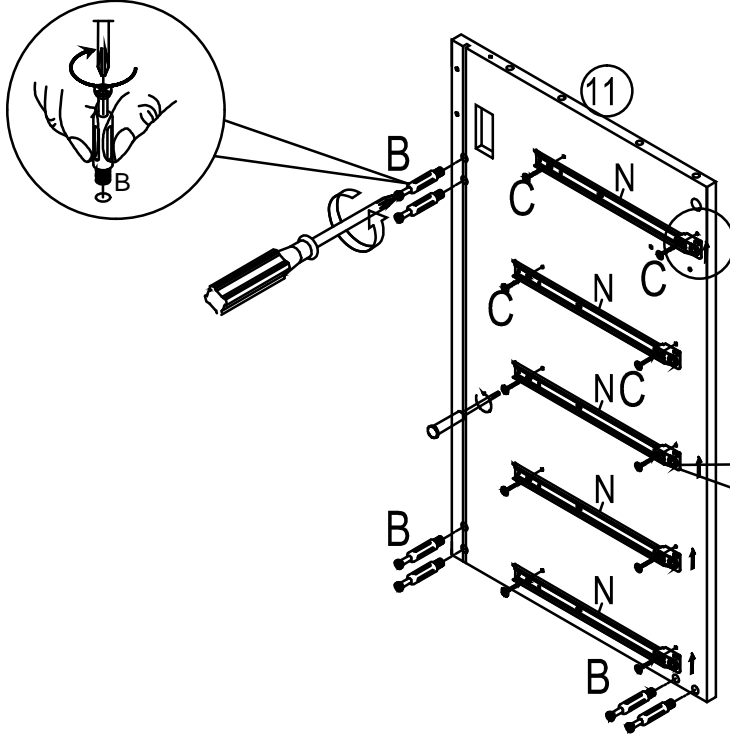

B		x6
---	---	----

STEP 6

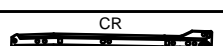

B		x6
C		x10
N		x5

INSTALLATION INSTRUCTIONS

STEP 7

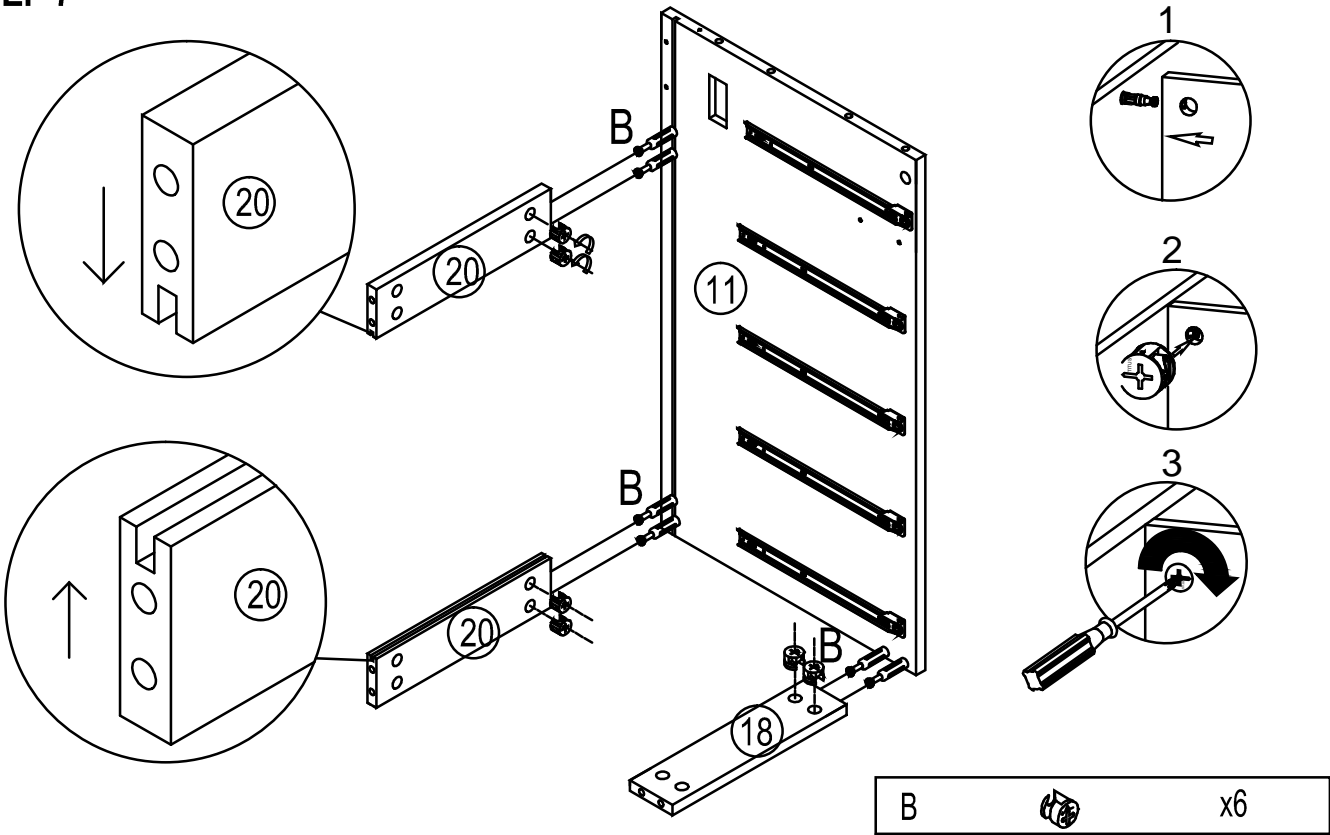

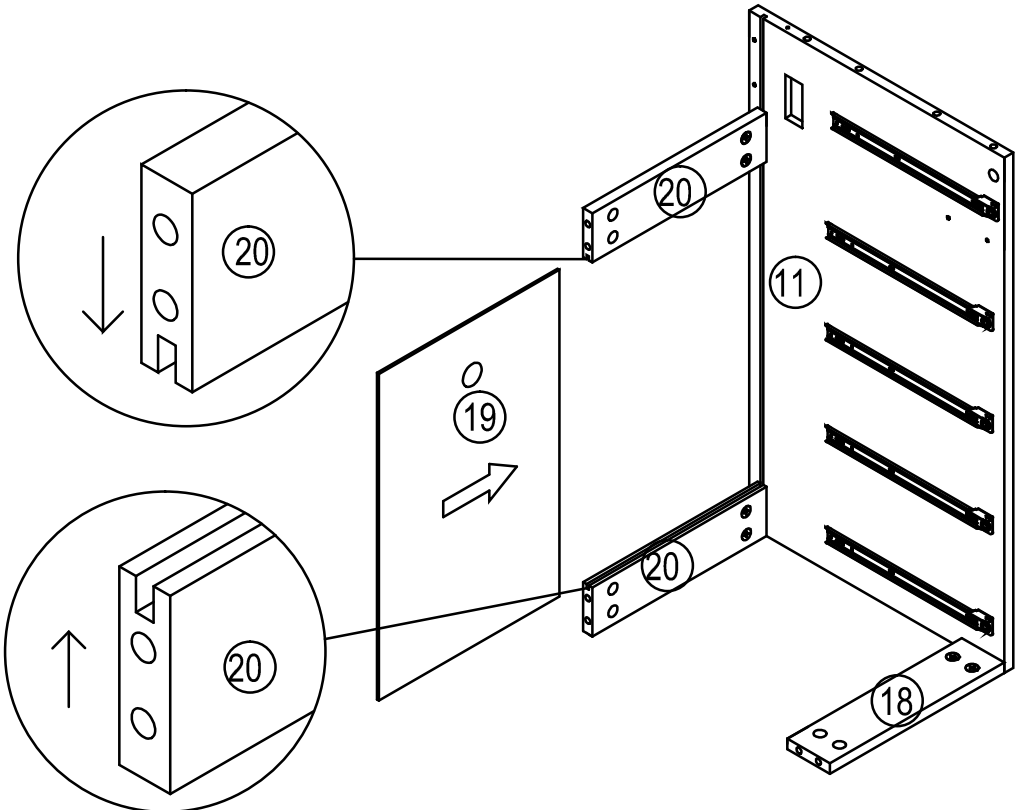

STEP 8



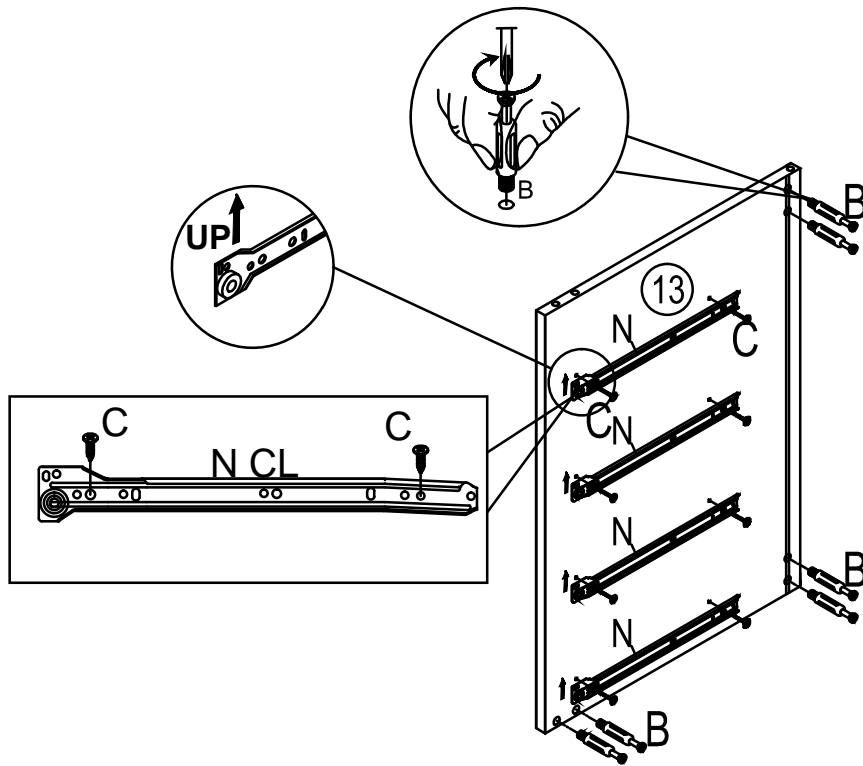

STEP 9

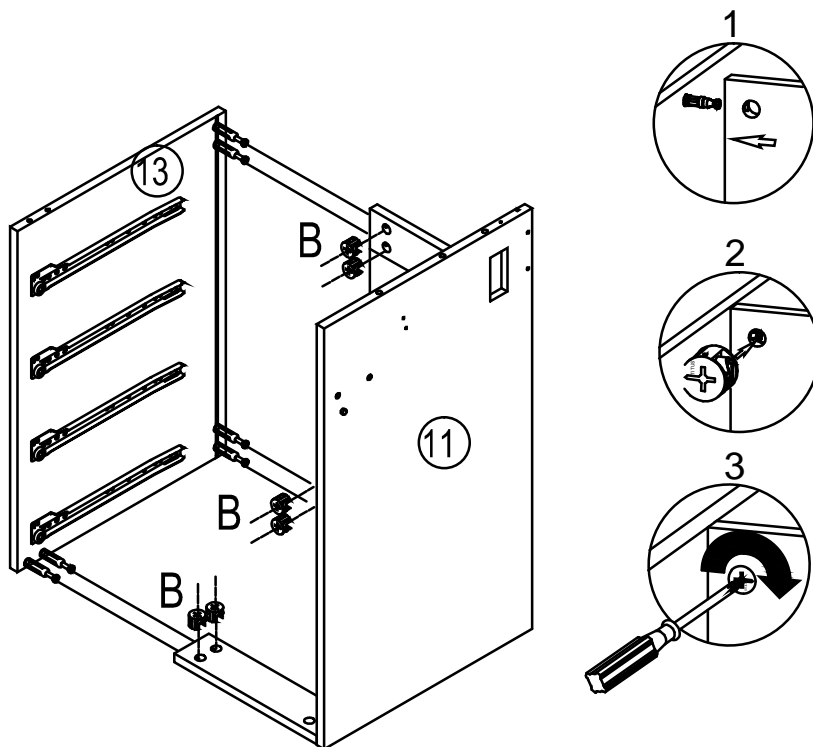

B		x6
C		x8
N		x4

STEP 10



B		x6
---	---	----

STEP 11

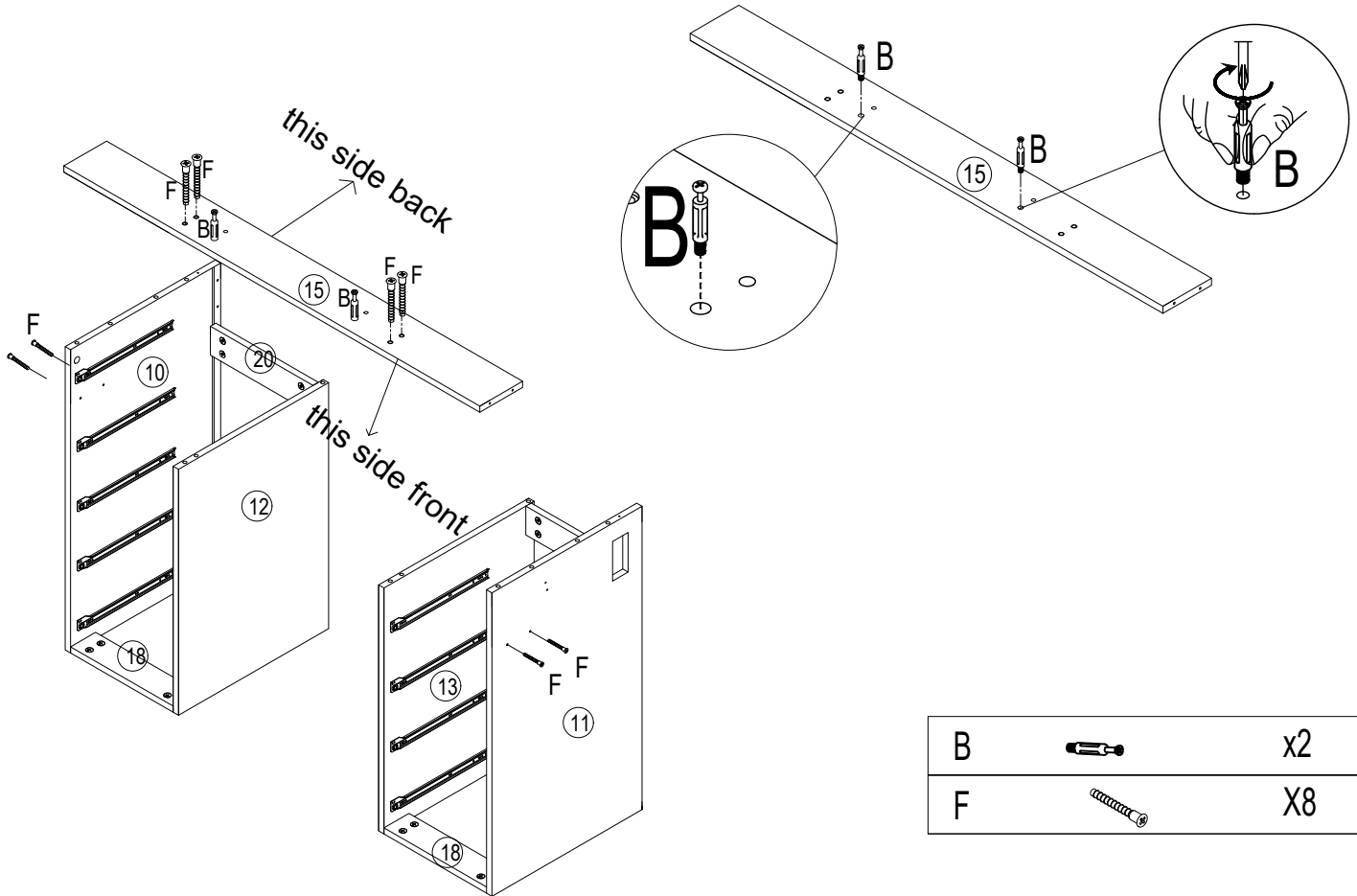

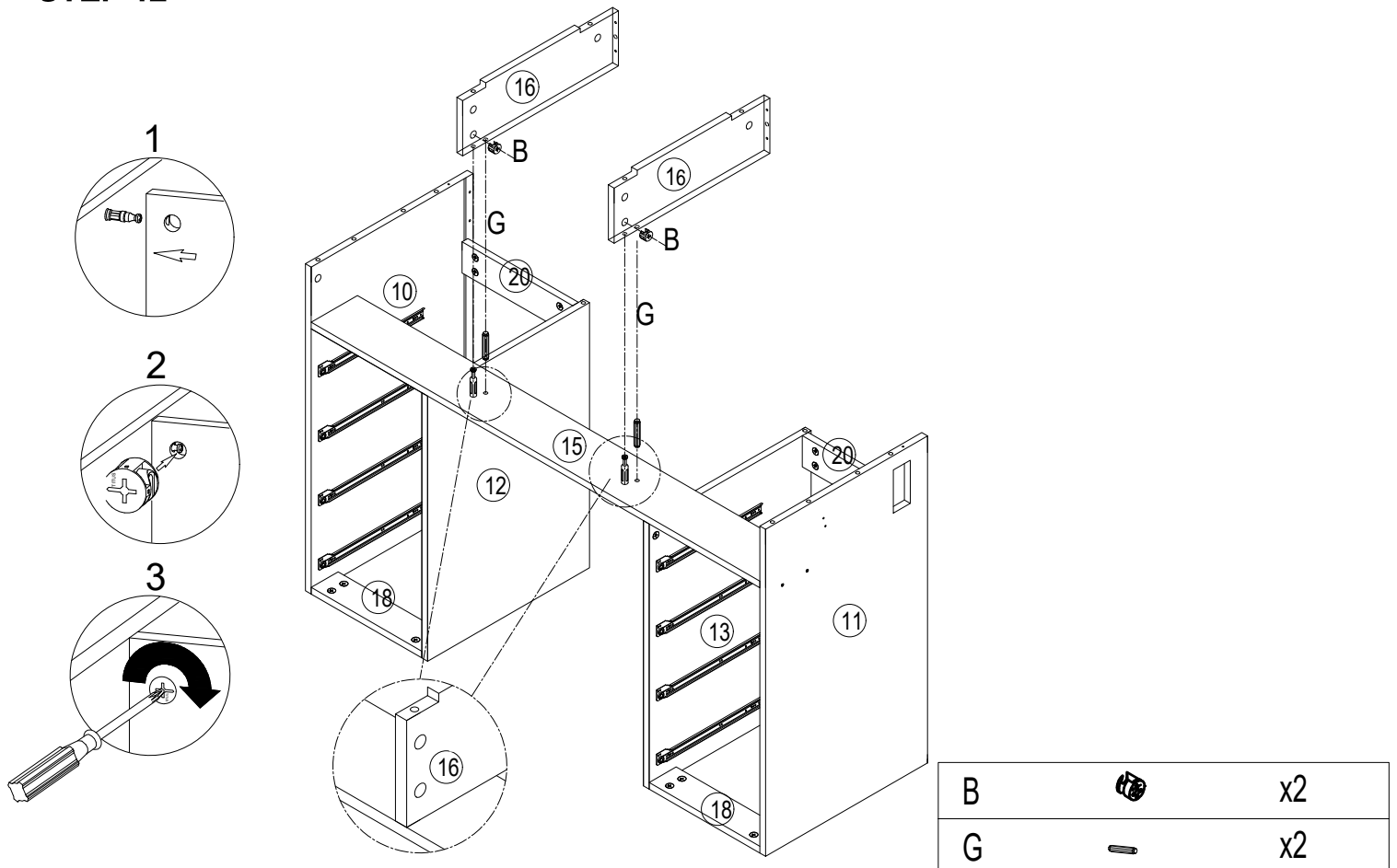

STEP 12

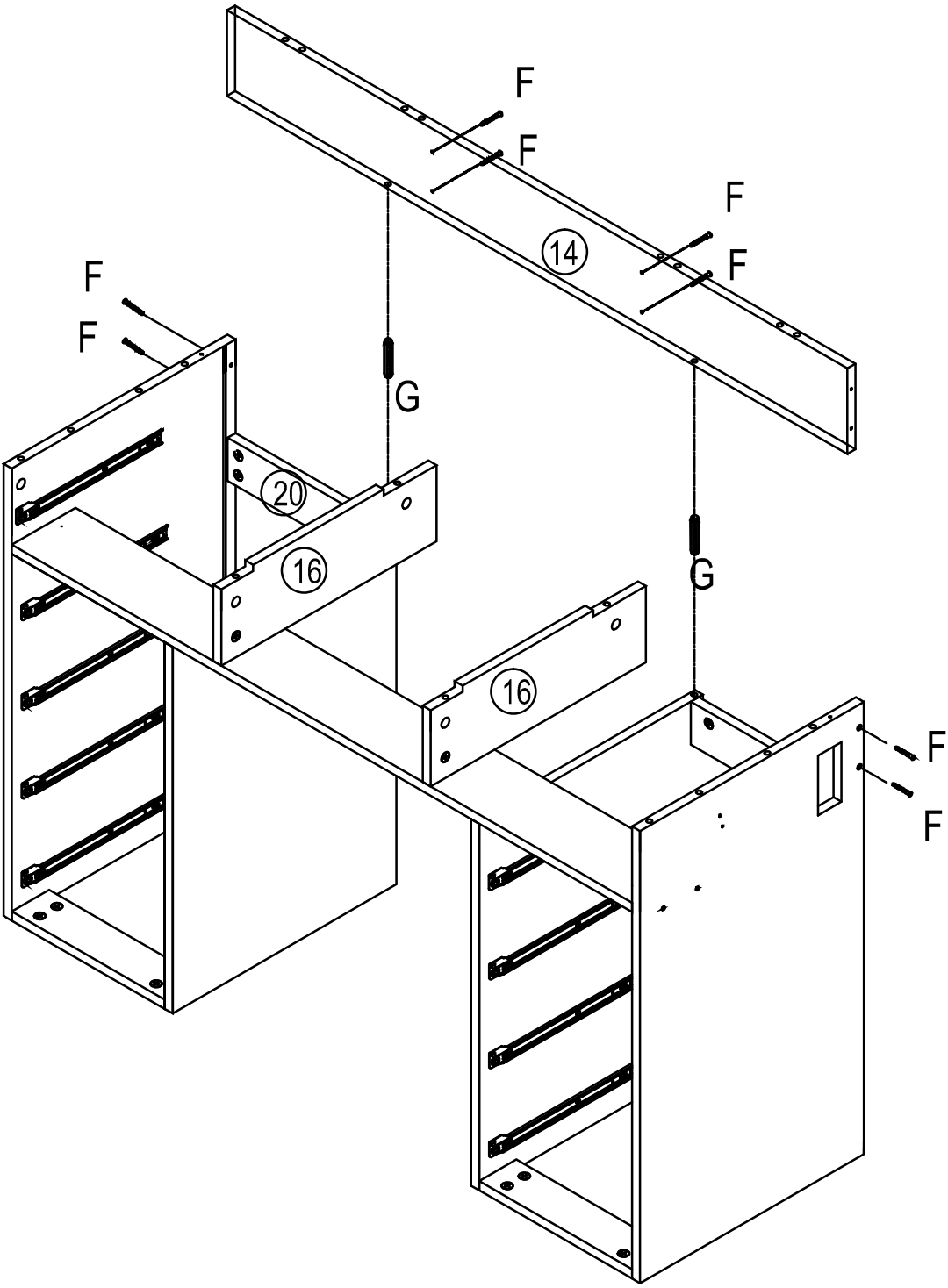

STEP 13



G		x2
F		x8

STEP 14

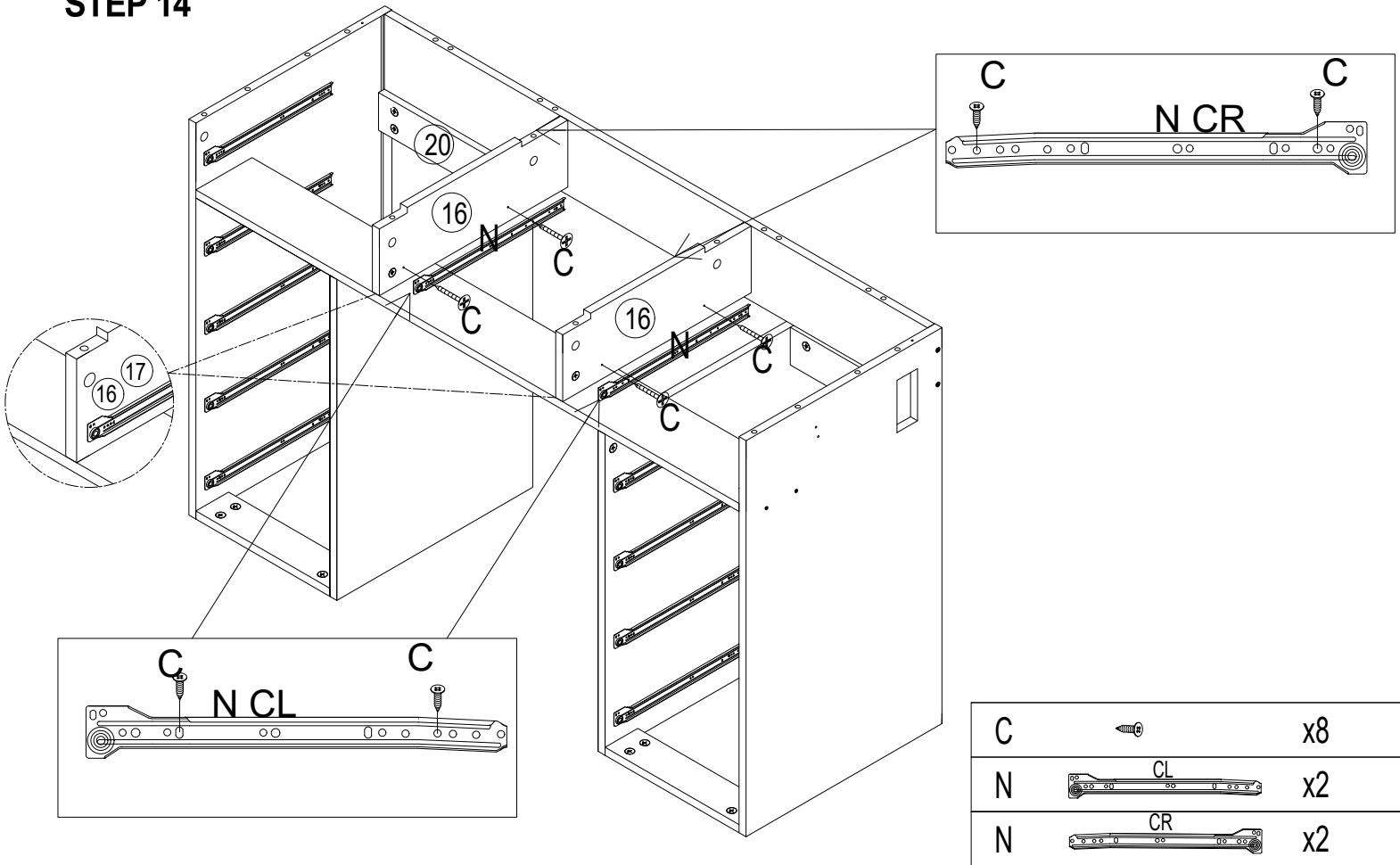

STEP 15

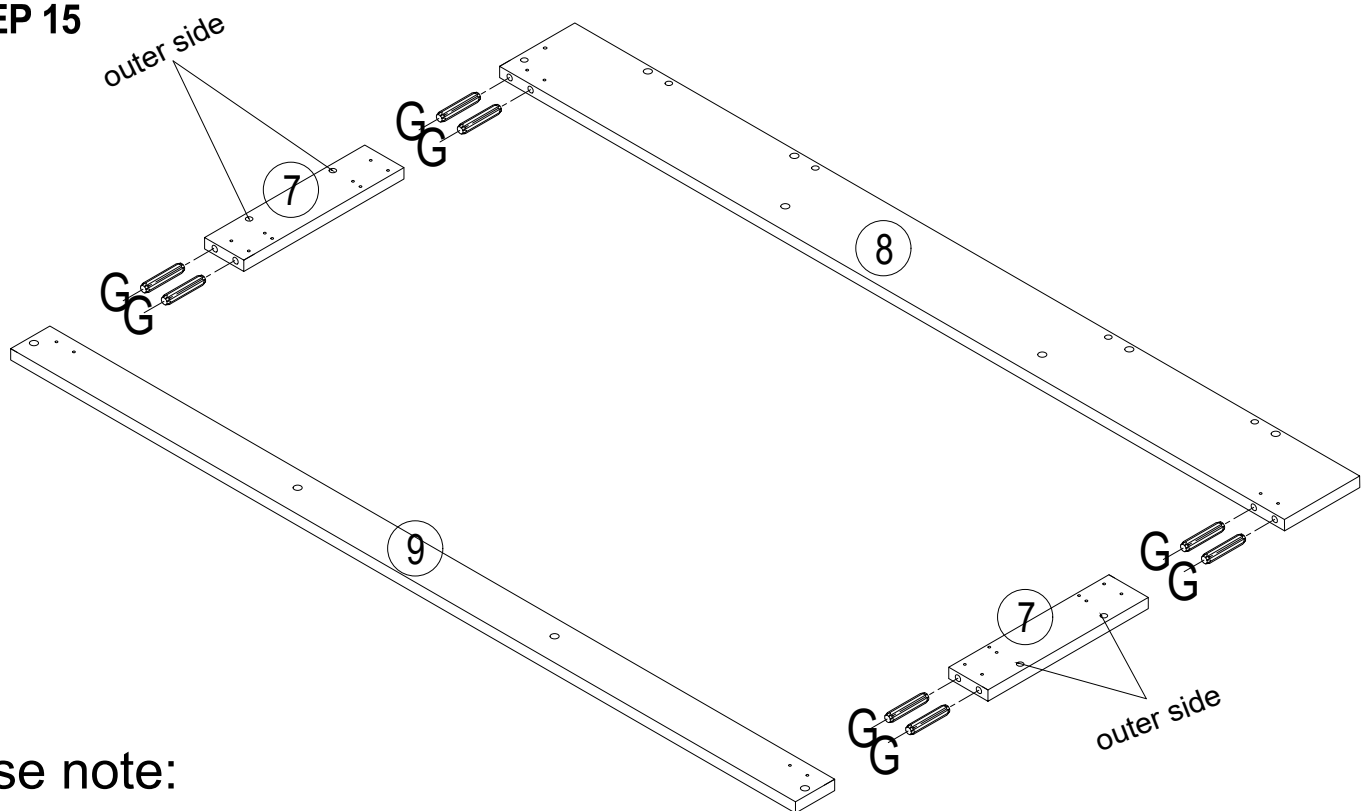

Please note:

The two larger holes on the ⑦ board are relocated on the outer side.

STEP 15

The four small holes on the ⑦, ⑧ and ⑨ boards are arranged side by side.

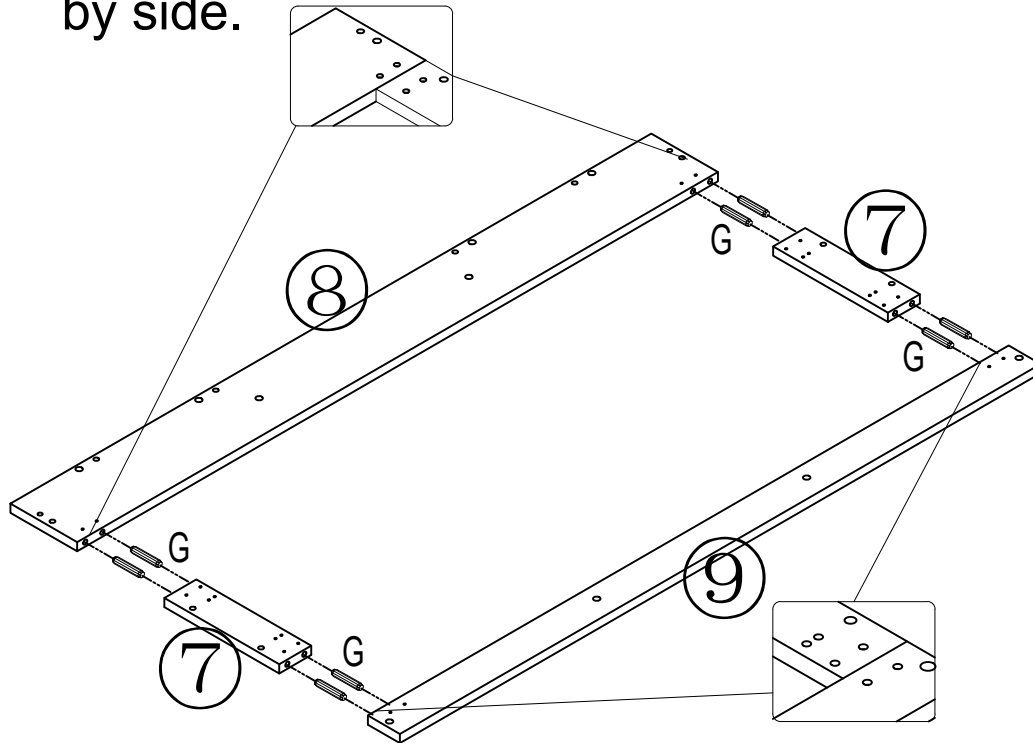

STEP 15

Please note:

The two larger holes on the ⑦ board are relocated on the outer side.

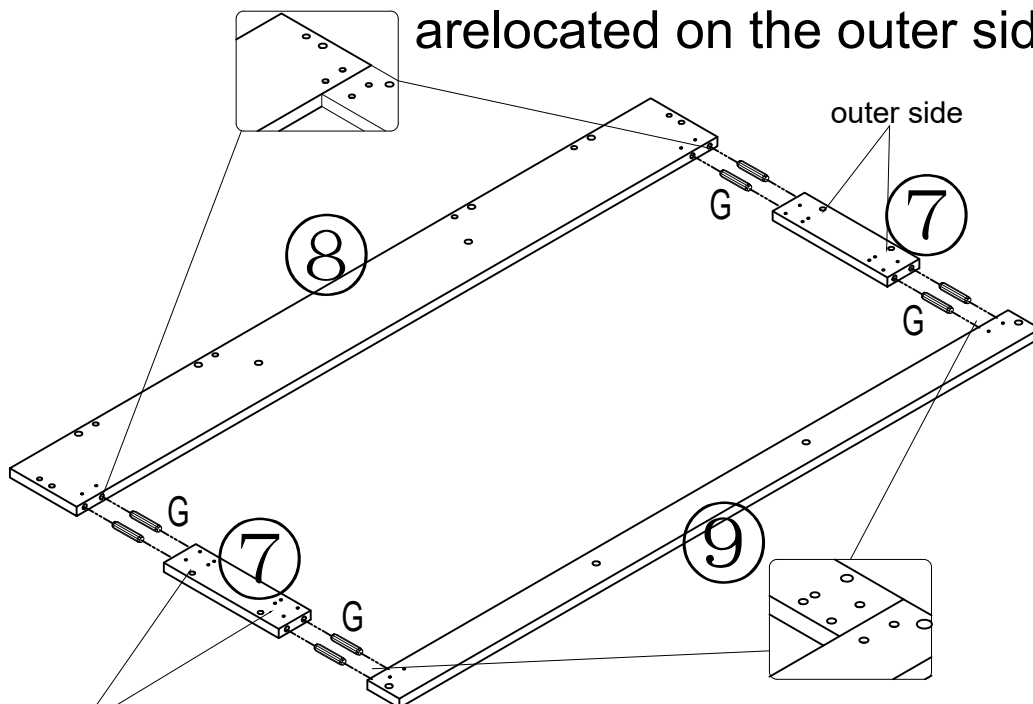

Please note: The two larger holes on the ⑦ board are relocated on the outer side.

The four small holes on the ⑦, ⑧ and ⑨ boards are arranged side by side.

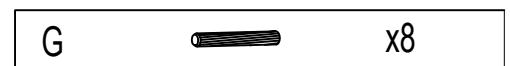

STEP 16

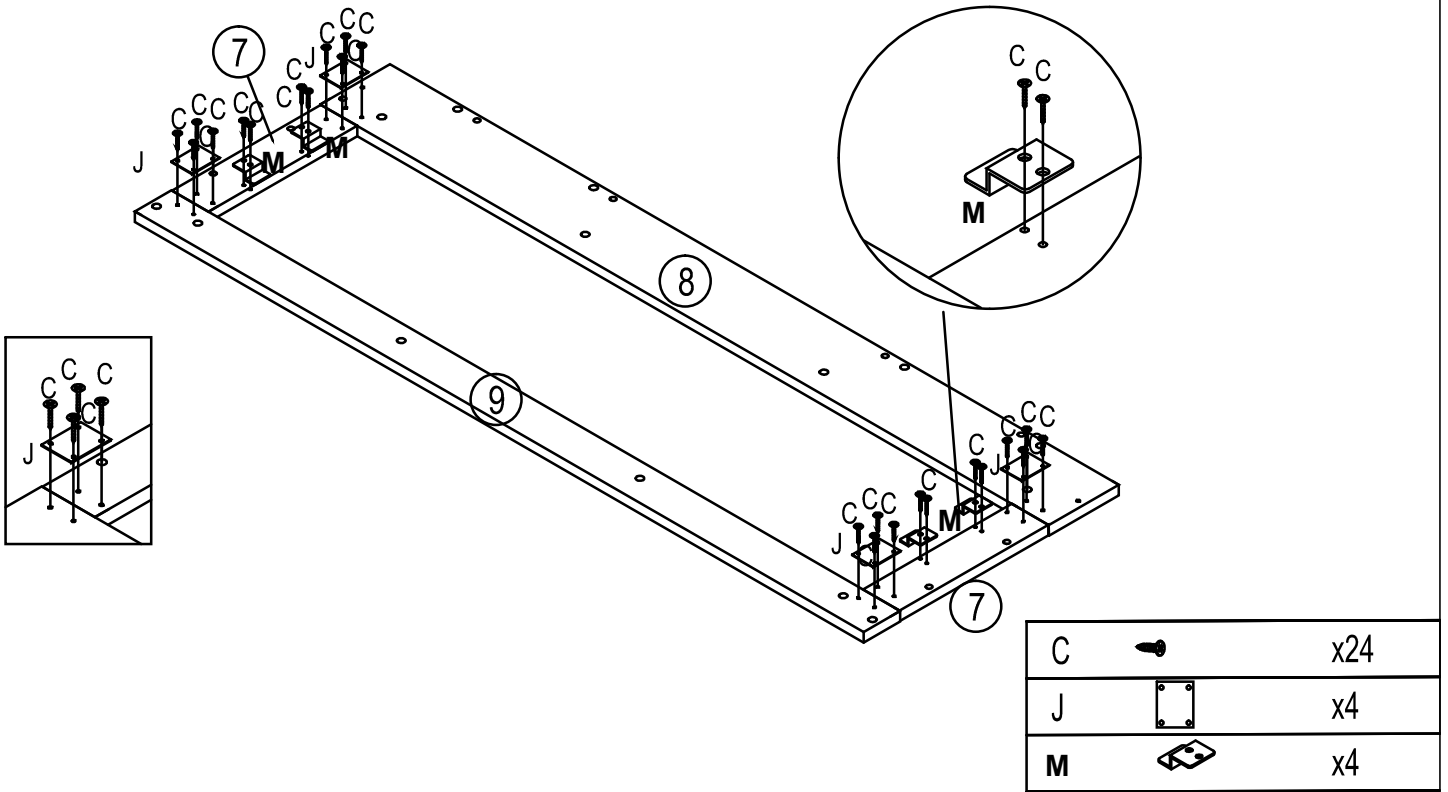

STEP 17

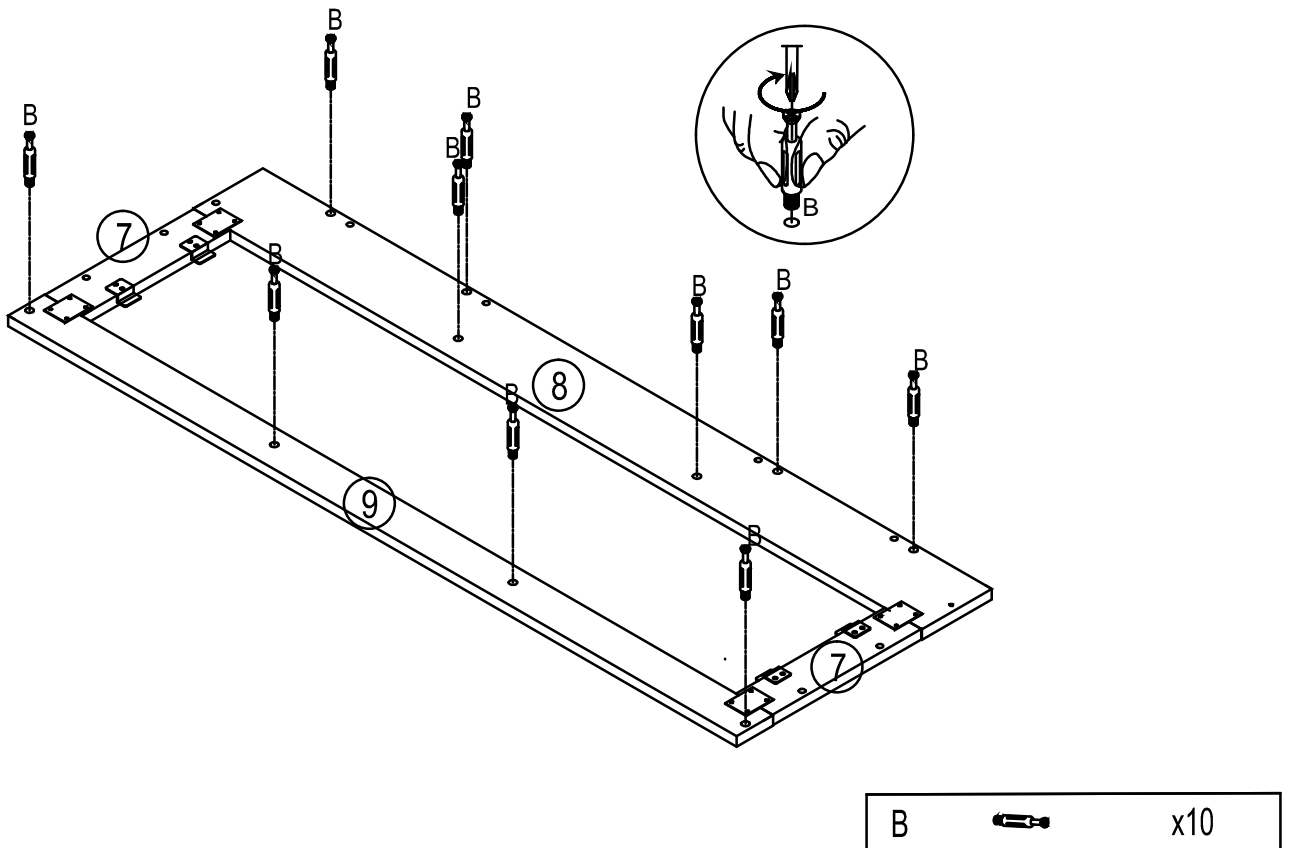

INSTALLATION INSTRUCTIONS

STEP 18

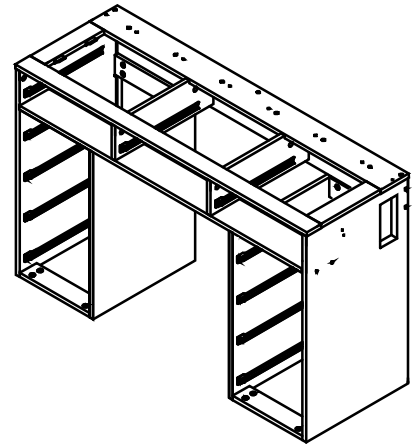
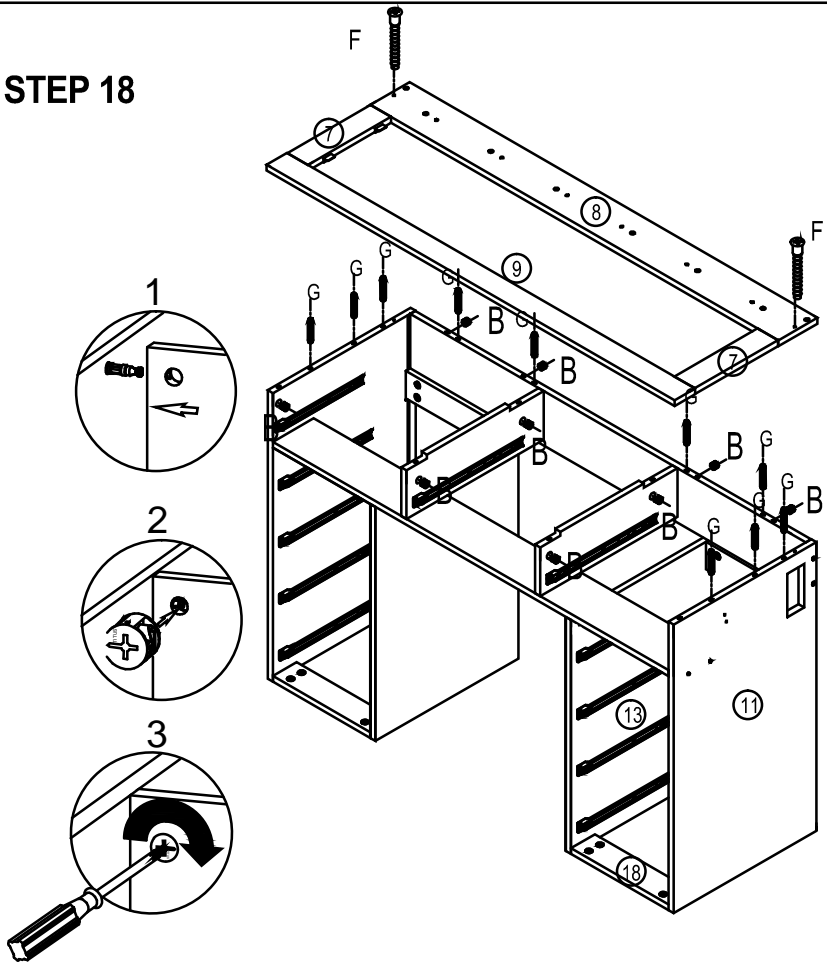

B		x10
F		x2
G		x10

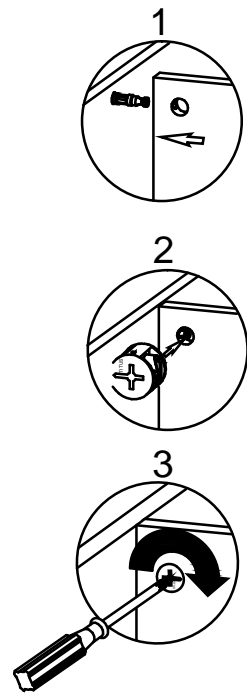
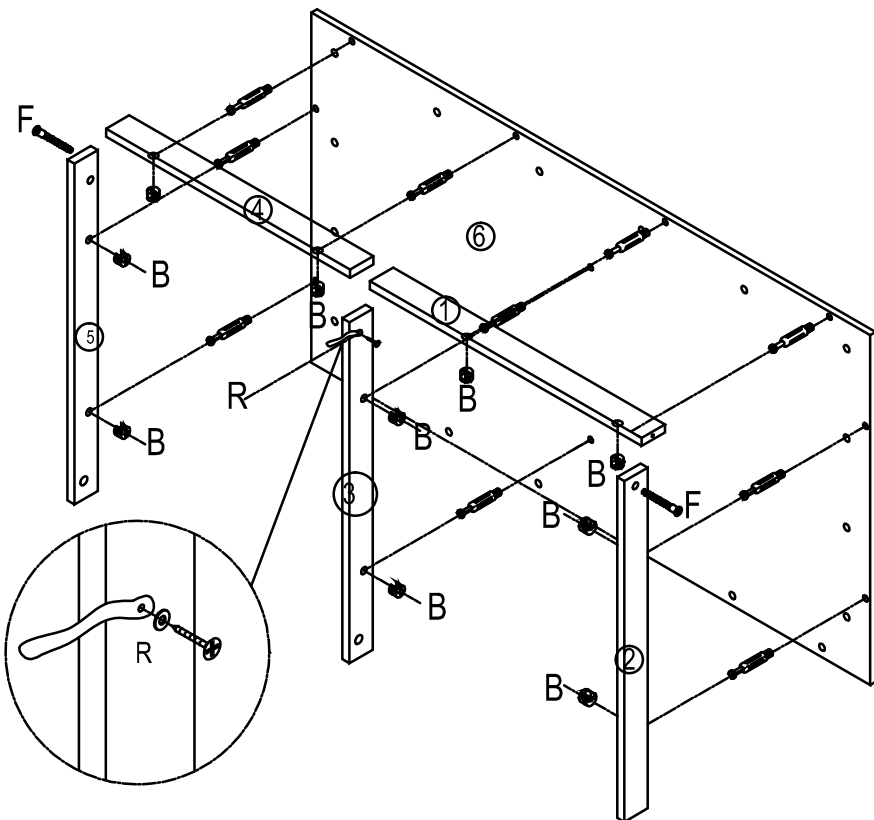

STEP 19



B		x10
F		x2
R		x1

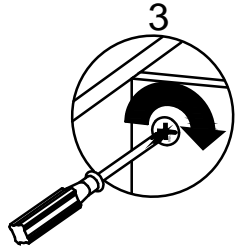
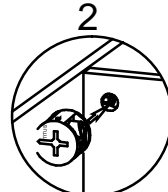
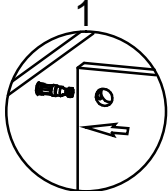
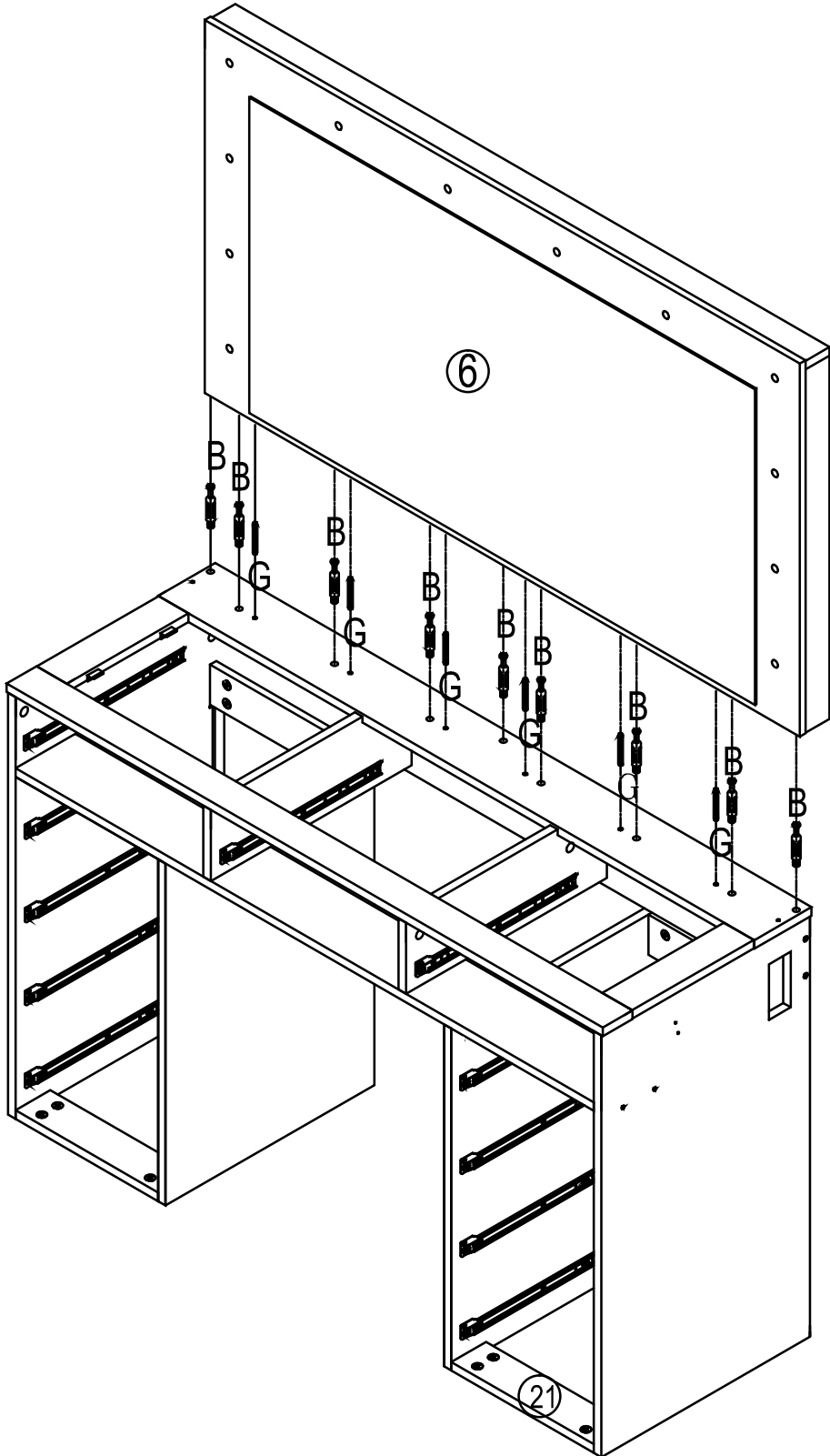

STEP 20

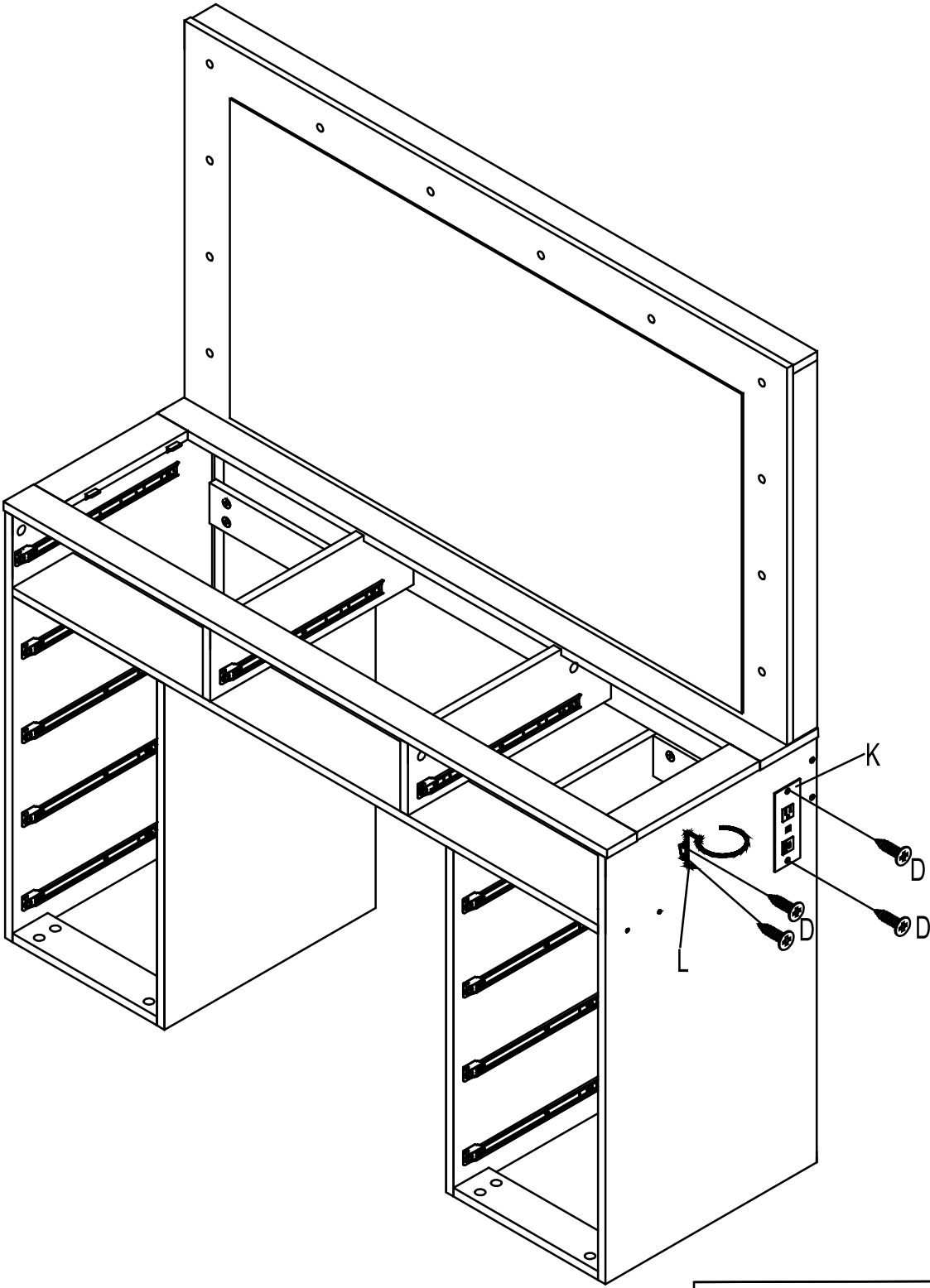

B		x9
G		x6

STEP 21



D		x4
K		x1
L		x1

INSTALLATION INSTRUCTIONS

STEP 22

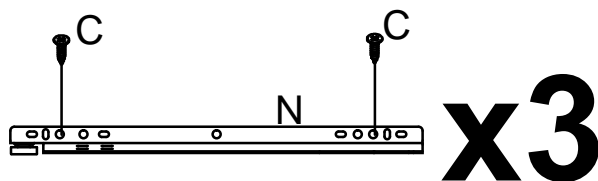
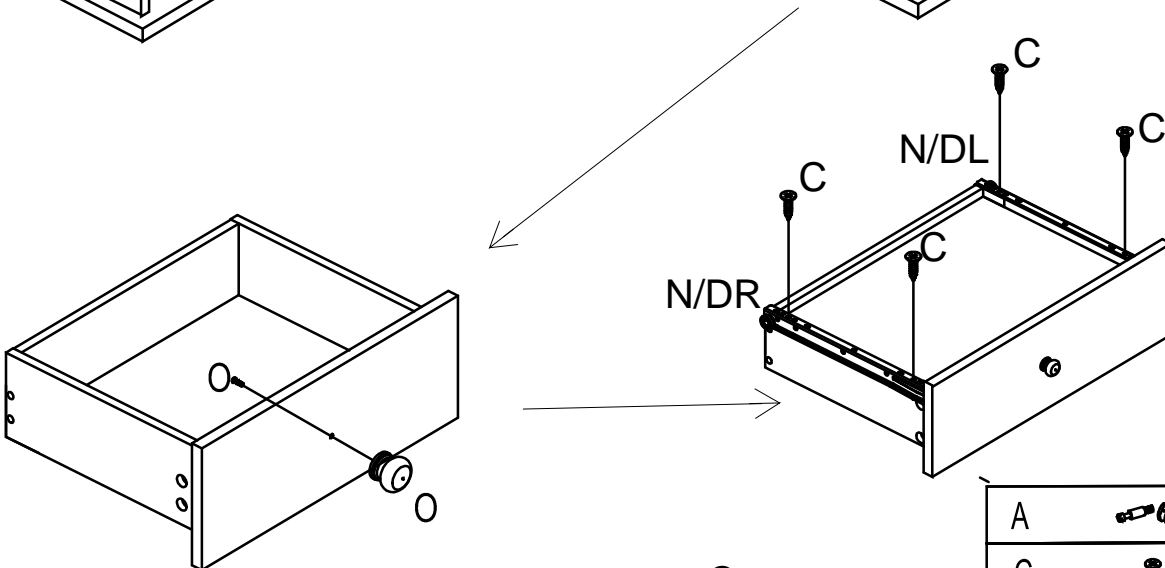
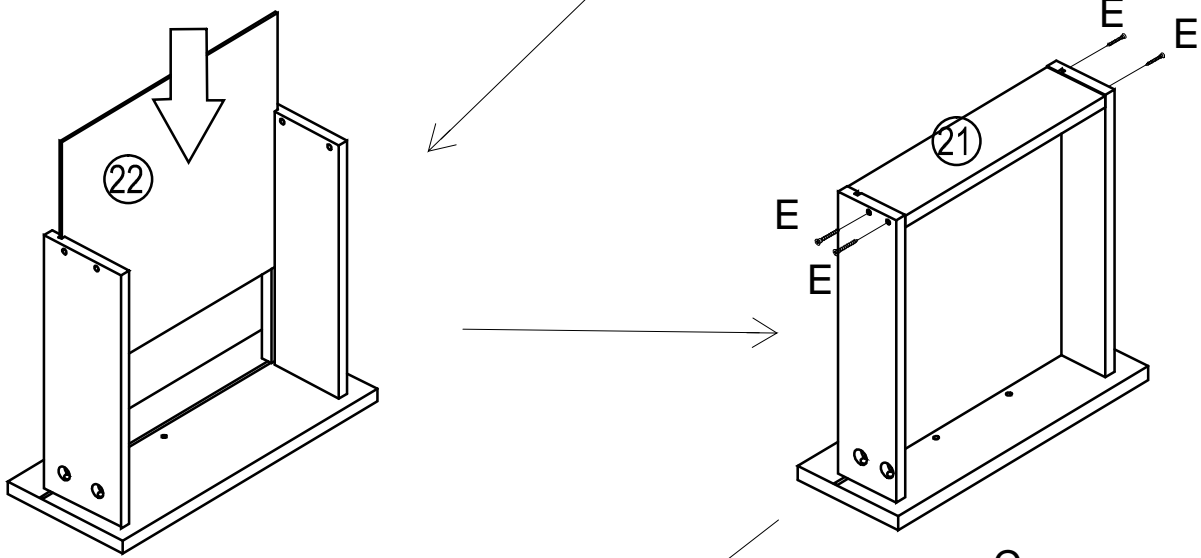
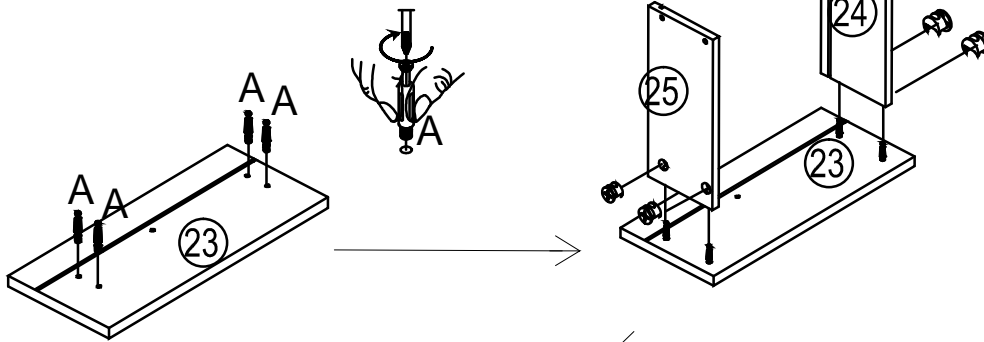

x3

A		x12
C		x12
E		x12
O		x3
N		x3

STEP 23

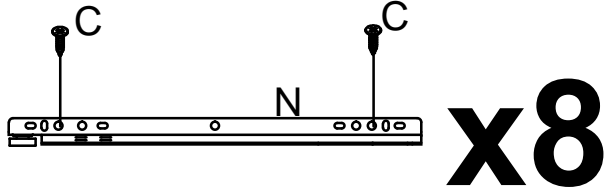
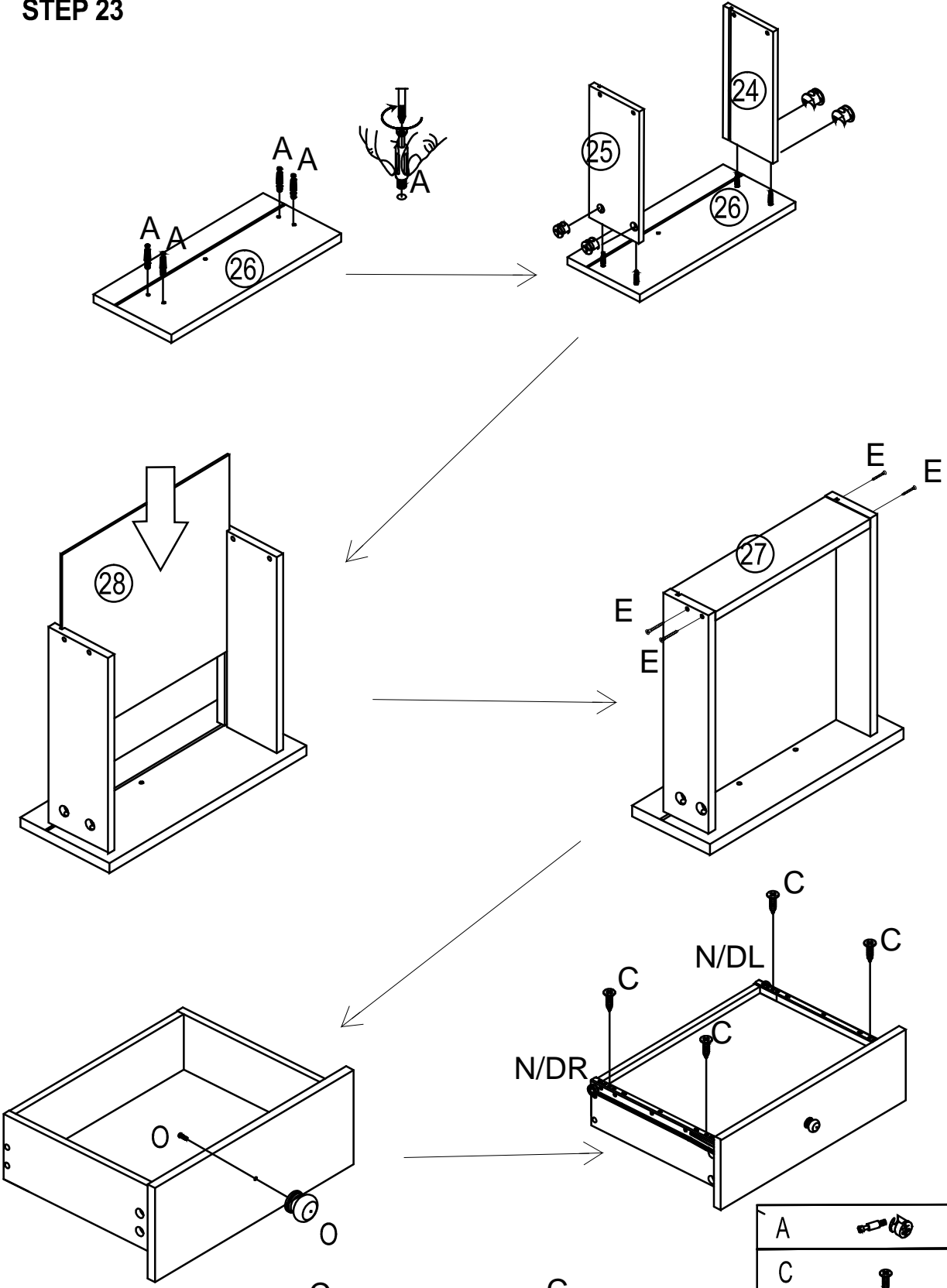

A		x32
C		x32
E		x32
O		x8
N		x8

STEP 24

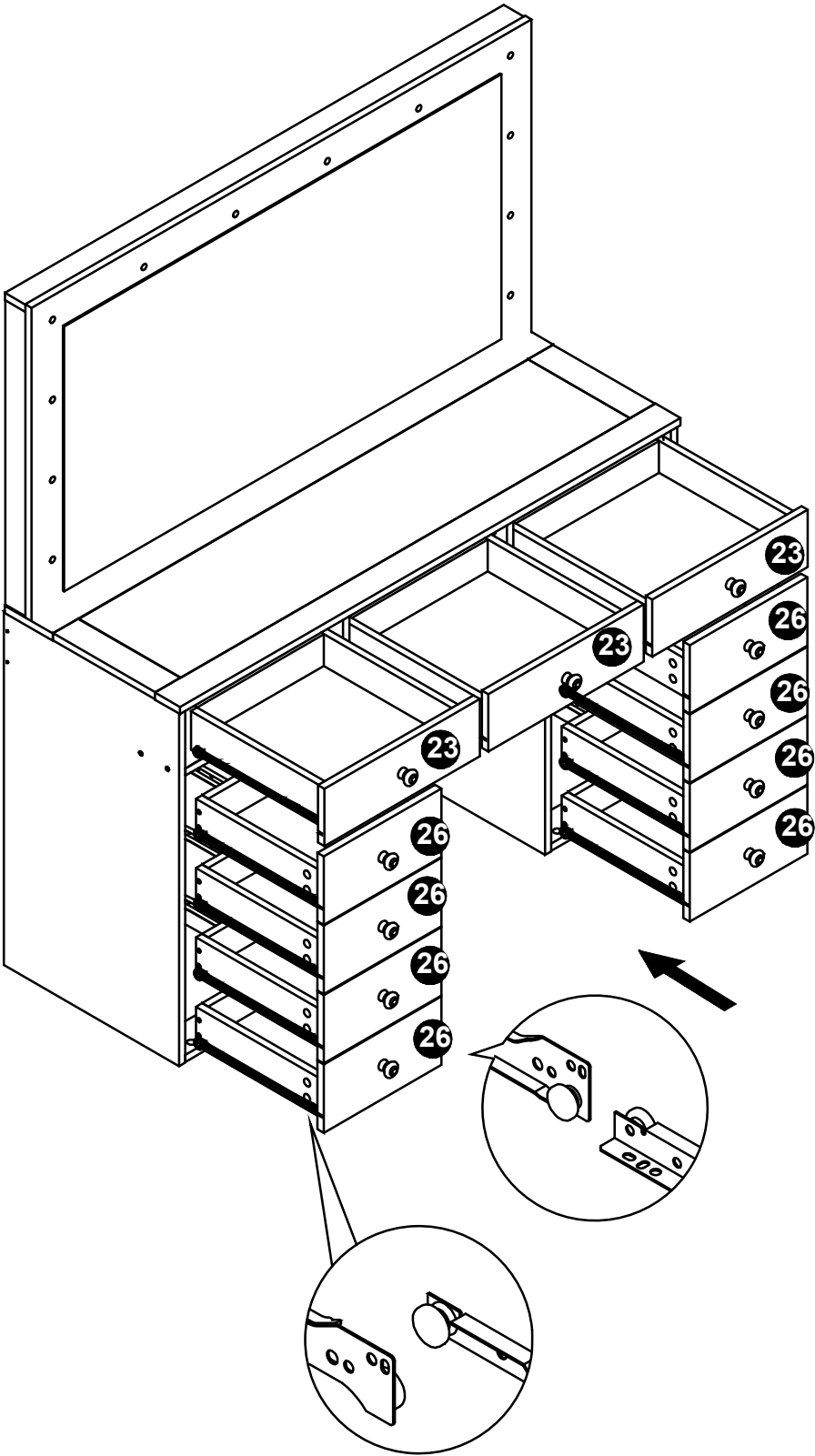

STEP 25

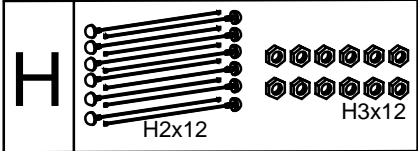
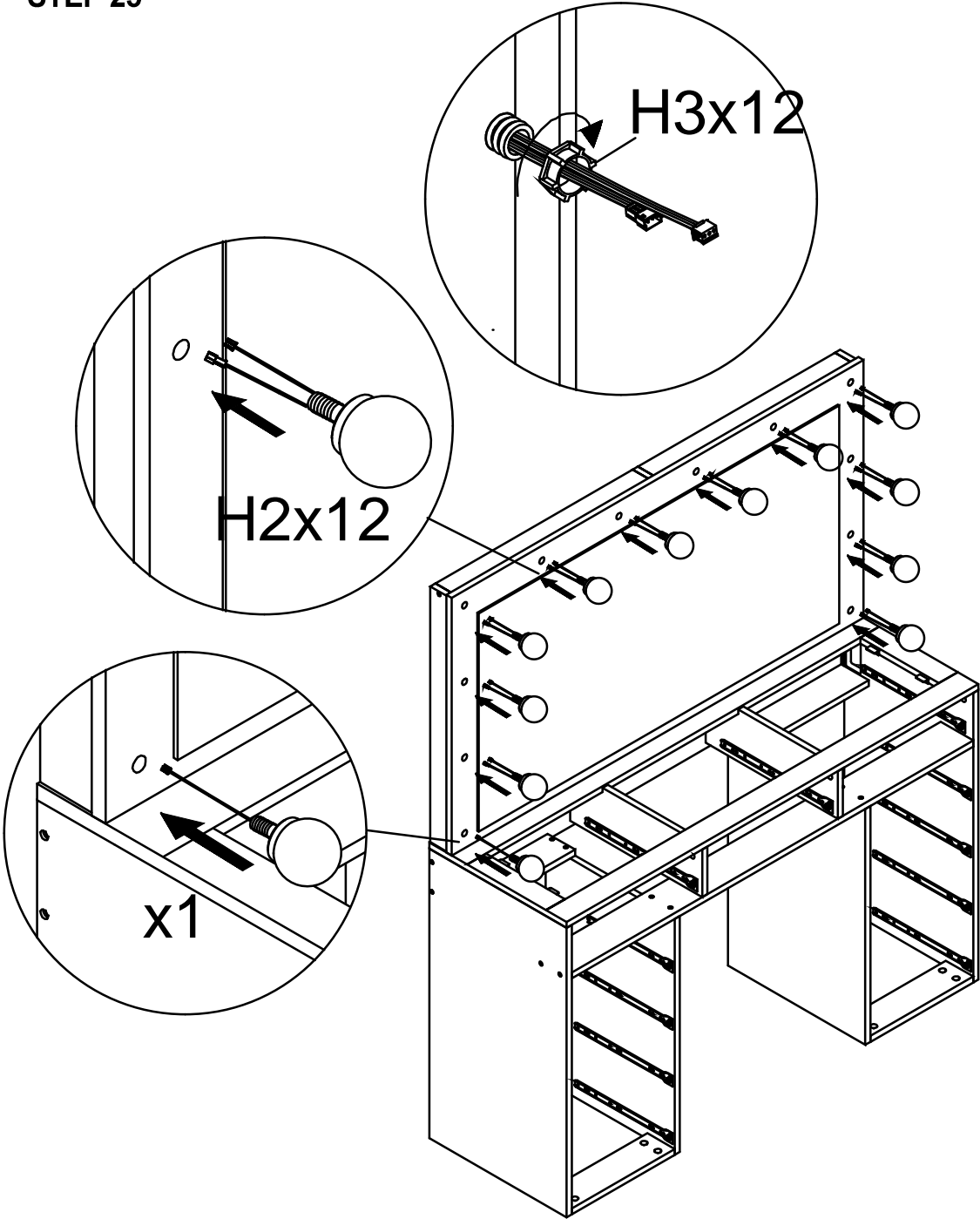



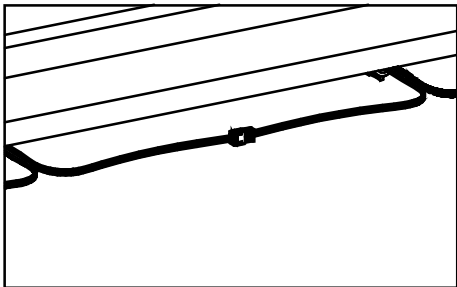
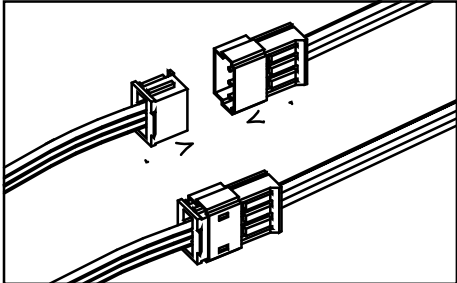
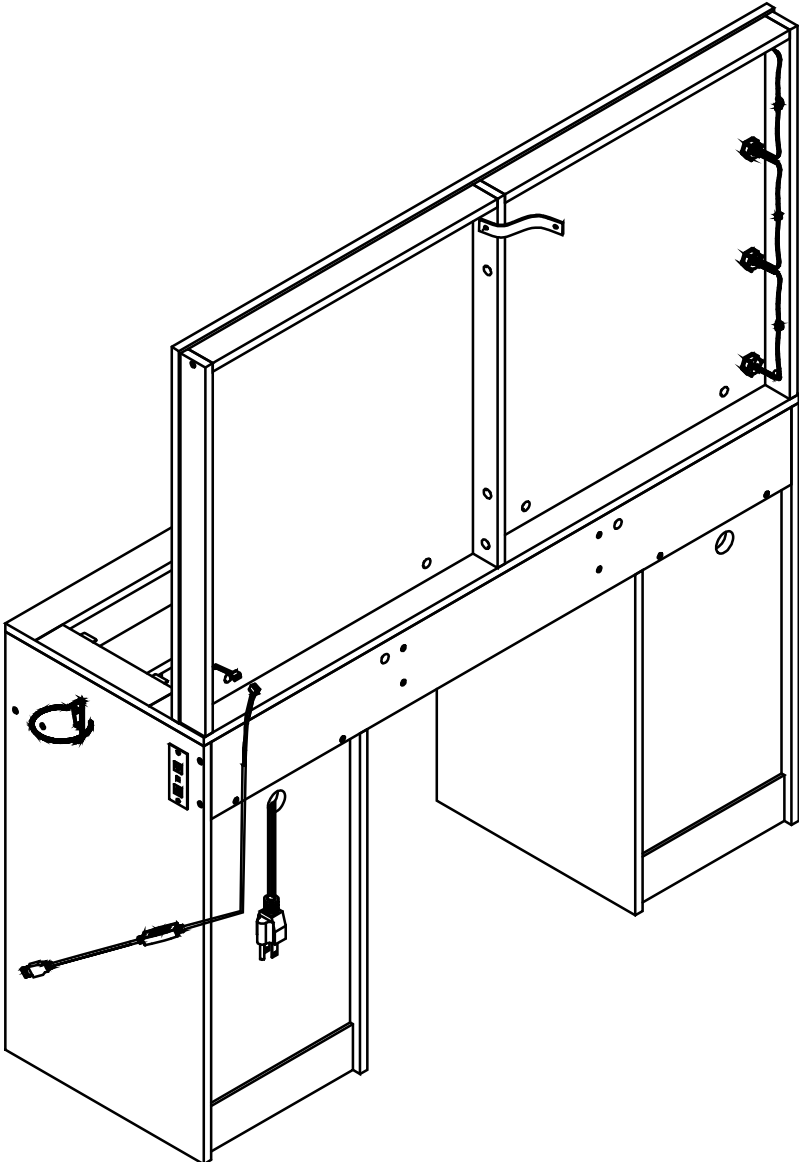

STEP 26

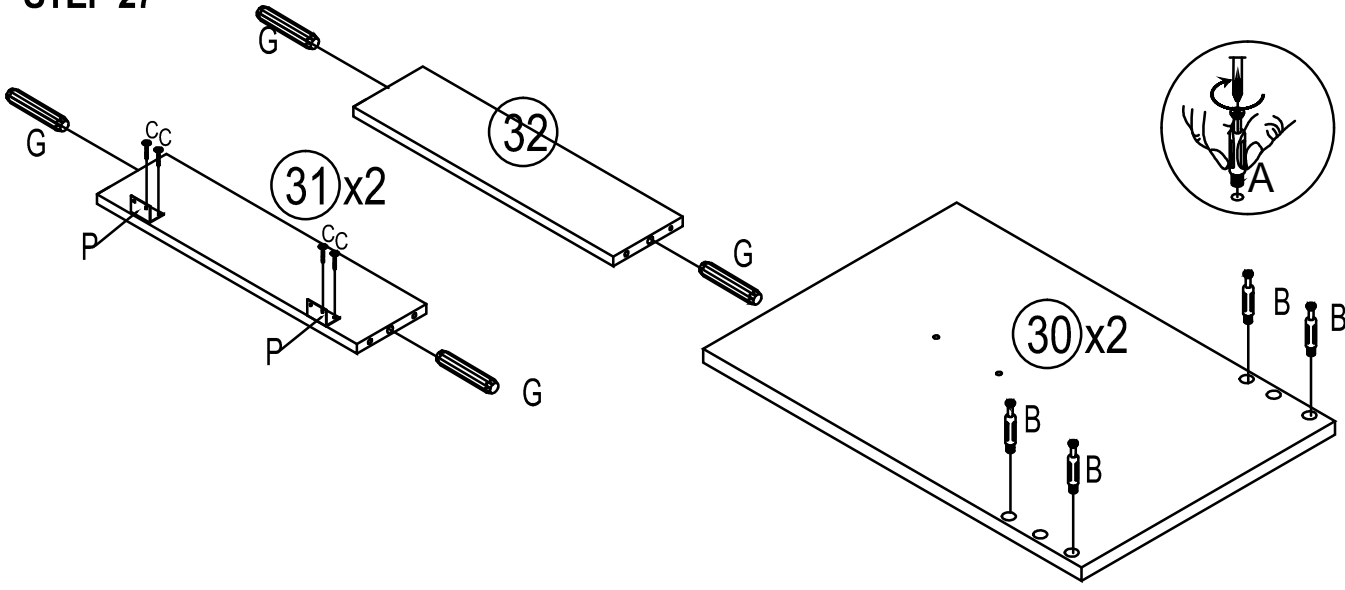

INSTALLATION INSTRUCTIONS



STEP 27

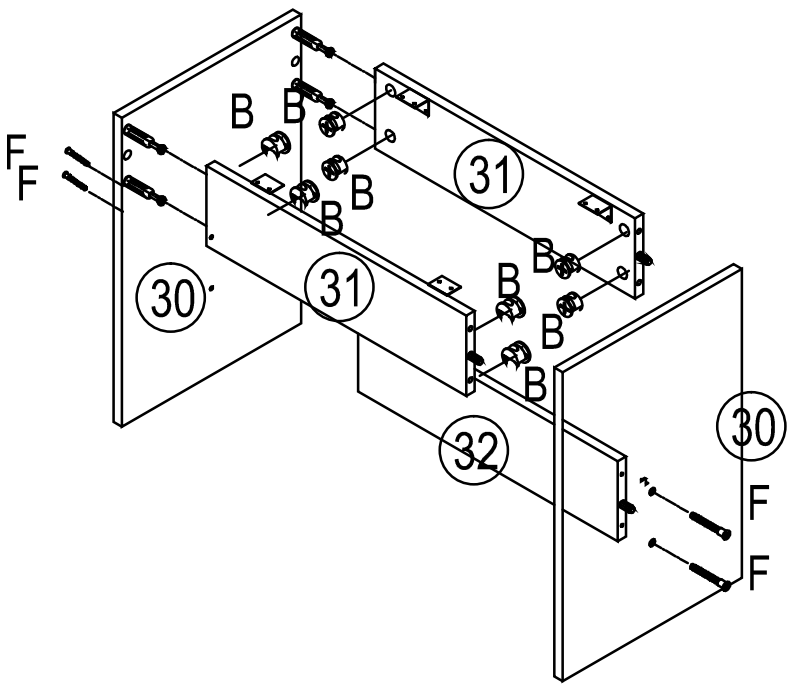

B		x8
C		x8
P		x4
G		x6

STEP 28



B		x8
F		x4

STEP 29

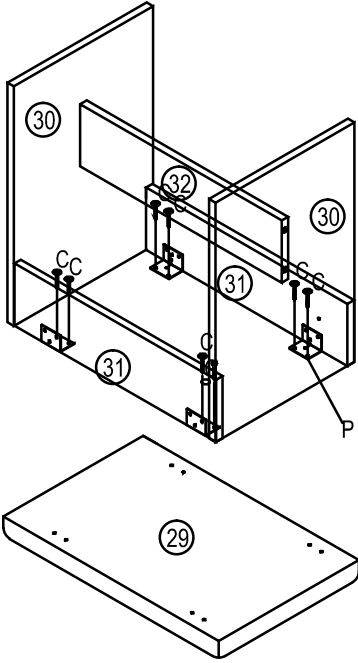

C		x8
---	---	----

STEP 30

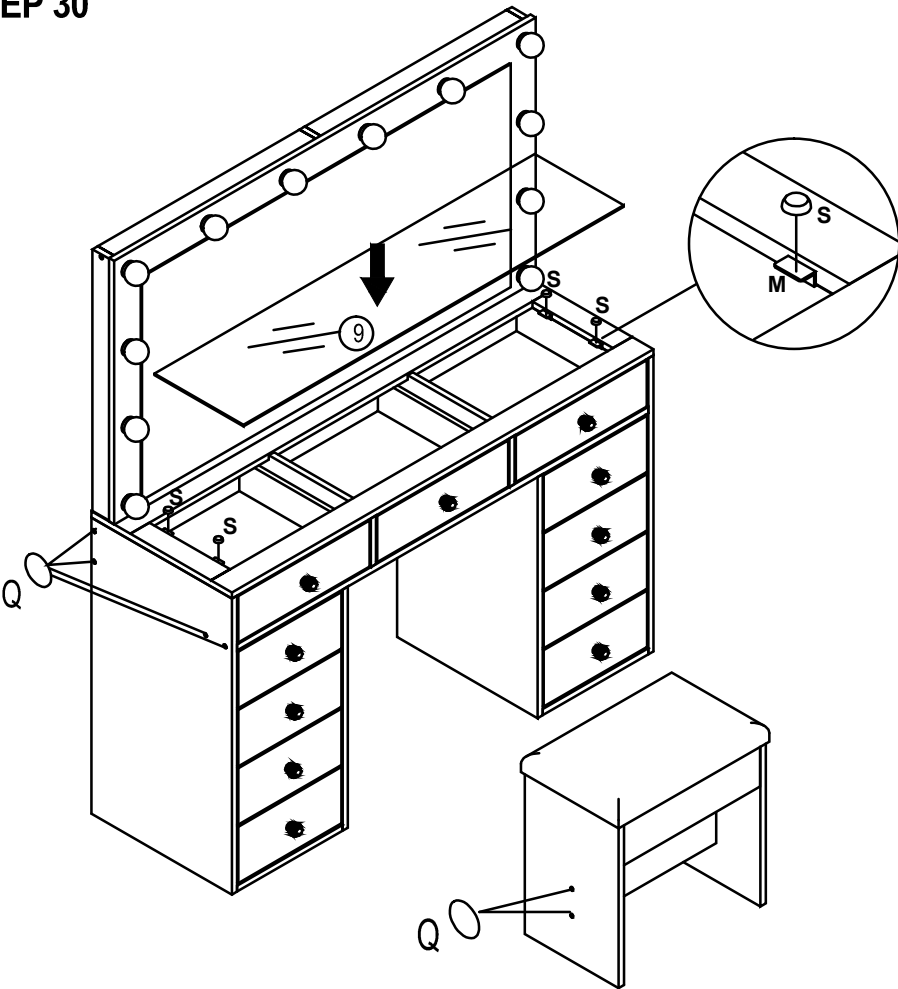

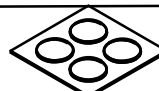
Q		x14
S		x4

STEP 31

