

Top View

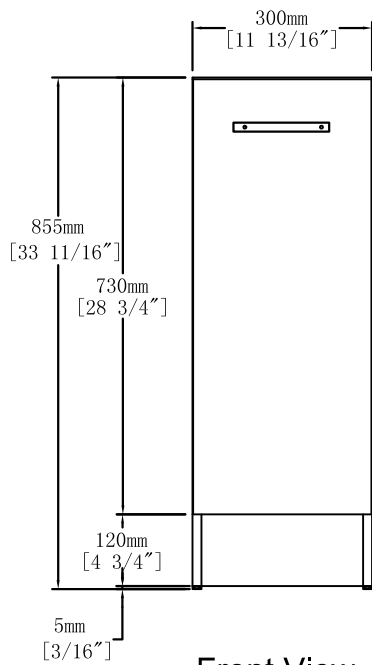

Front View

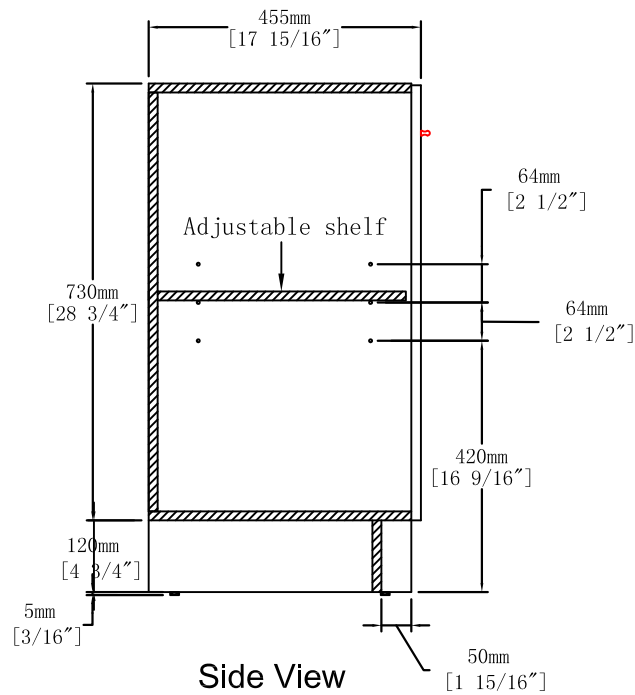

Side View

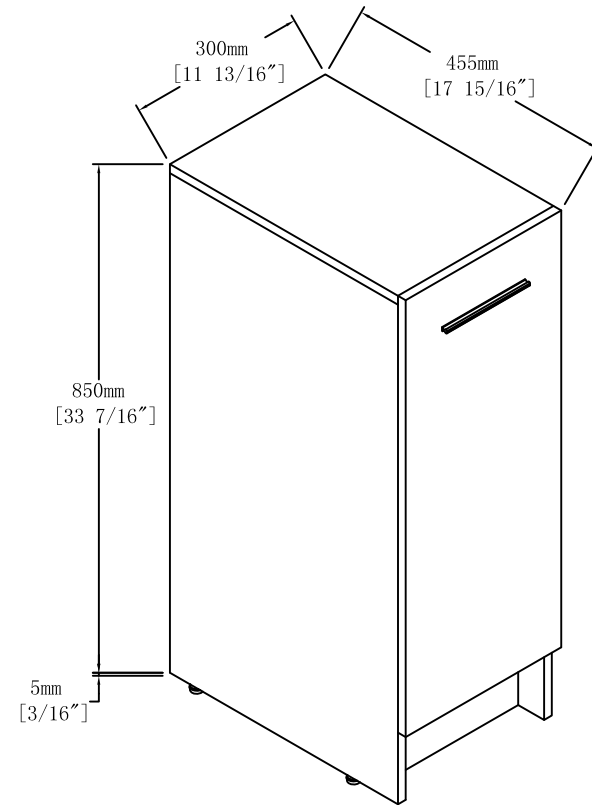

	Item NO.	UNOR SV 006F 12S	Version	V1
	Project		Date	2025-11-11