

# ASSEMBLY INSTRUCTIONS

Customer Service : [cs@nbrehome.com](mailto:cs@nbrehome.com)

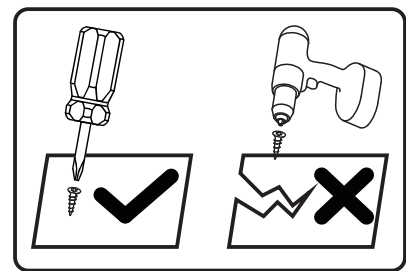
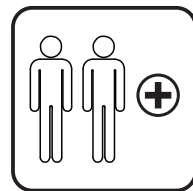
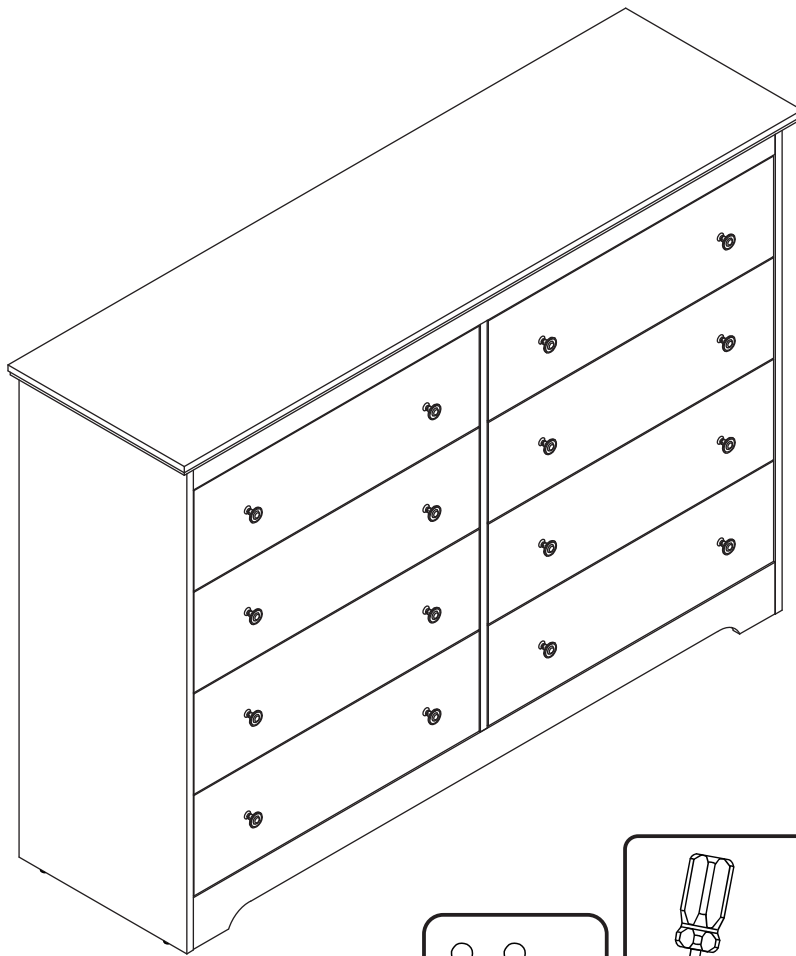

## Tools Recommended

THIS INSTRUCTIONS CONTAINS IMPORTANT SAFETY INFORMATION.  
PLEASE READ BEFORE ASSEMBLY AND KEEP FOR FUTURE REFERENCE.

Need Parts or Assistance? Email us : [cs@nbrehome.com](mailto:cs@nbrehome.com)

# IMPORTANT NOTICE

- This product contains small components, please ensure that they are kept away from small children.
- THIS INSTRUCTIONS CONTAINS IMPORTANT SAFETY INFORMATION. PLEASE READ BEFORE ASSEMBLY AND KEEP FOR FUTURE REFERENCE.
- Read each step carefully. It is very important that each step of instruction is performed in the correct order. If these steps are not followed in sequence, assembly difficulties will occur.
- Make sure all parts are included. Most parts are labelled or stamped on the raw edge.
- Work in spacious area, preferably on a carpet, near the place the unit will be used.
- Do not use power tools to assemble your furniture. Power tools may strip or damage the parts.
- Move your new furniture carefully, with two people lift and carry the unit to it's new location.
- Never push, drag or pull your furniture (especially on carpet)





## PLEASE DO NOT RETURN PRODUCT TO US IMMEDIATELY

If a part is missing or damaged, email our customer service. We will gladly ship your replacement parts FREE of charge.

Need Parts or Assistance? Email us : [cs@nbrehome.com](mailto:cs@nbrehome.com)

For Prompt, reliable service, please have your assemble instruction ready

 <b>WARNING</b>	
	<b>Children have died from furniture tipover. To reduce the risk of furniture tipover:</b> <ul style="list-style-type: none"><li>- ALWAYS install Anti-tip device provided.</li><li>- NEVER put a TV on this product.</li><li>- NEVER allow children to stand, climb or hang on any drawers, doors, or shelves.</li><li>- NEVER open more than one drawer at a time.</li><li>- Place heaviest items in the lowest drawers.</li></ul>
	<p><i>This is a permanent label. Do not remove!</i></p>

Total number of boards required for this product: 61pcs

Includes frame plate: 12pcs

part 1\*1pc

part 2\*1pc

part 3\*1pc

part 4\*1pc

part 5\*1pc

part 6\*1pc

part 7\*1pc

part 8\*1pc

part 9\*1pc

part 10\*2pcs

part 11\*1pc

Includes feet: 1pc

part 18\*1pc

Includes drawer board: 48pcs

part 12\*8pcs

part 13\*8pcs

part 14\*8pcs

part 15\*8pcs

part 16\*8pcs

part 17\*8pcs

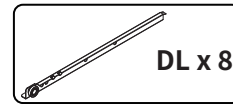
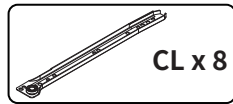
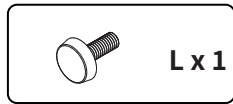
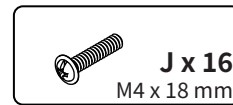
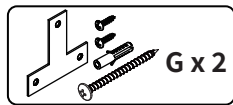
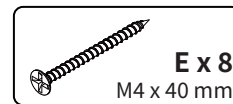
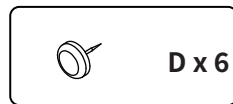
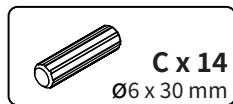
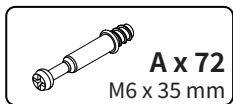
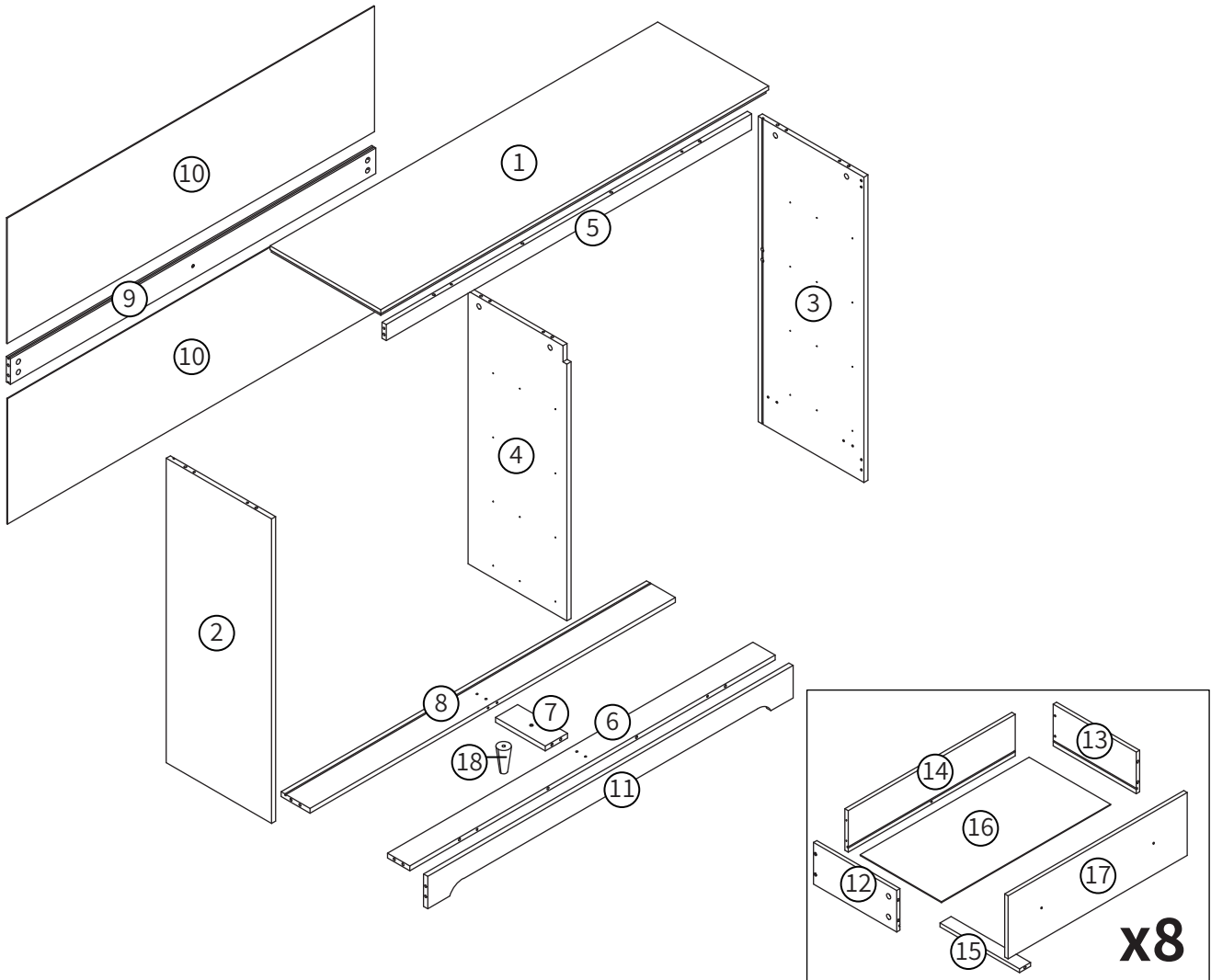

# Step 1

Lock the guide rail (**CL**) to the part ② with the screw (**H**), then lock the guide rail (**CR**) to the part ③ with the screw (**H**). The installation position is as shown in the figure below.

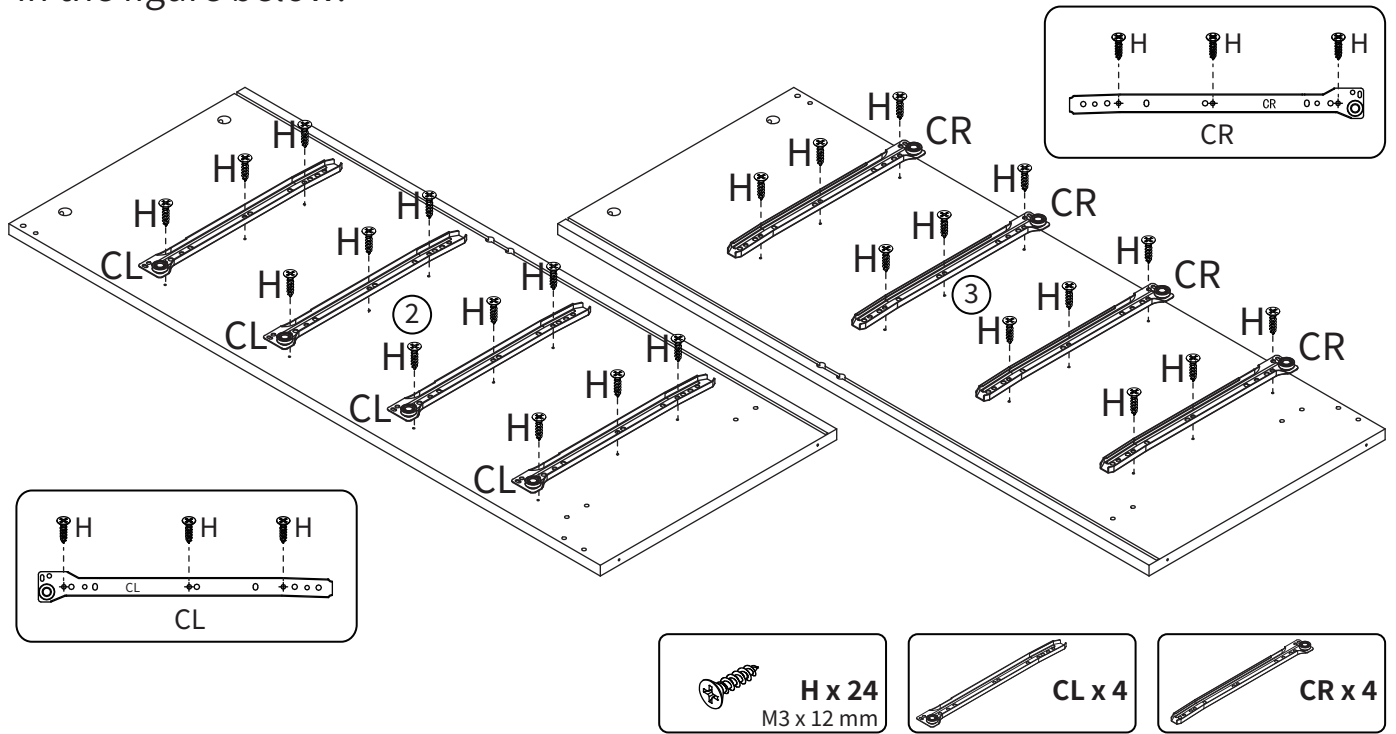

# Step 2

Lock screw (**A**) and foot pad (**D**) on the part ② and ③. The installation position is as shown in the figure below.

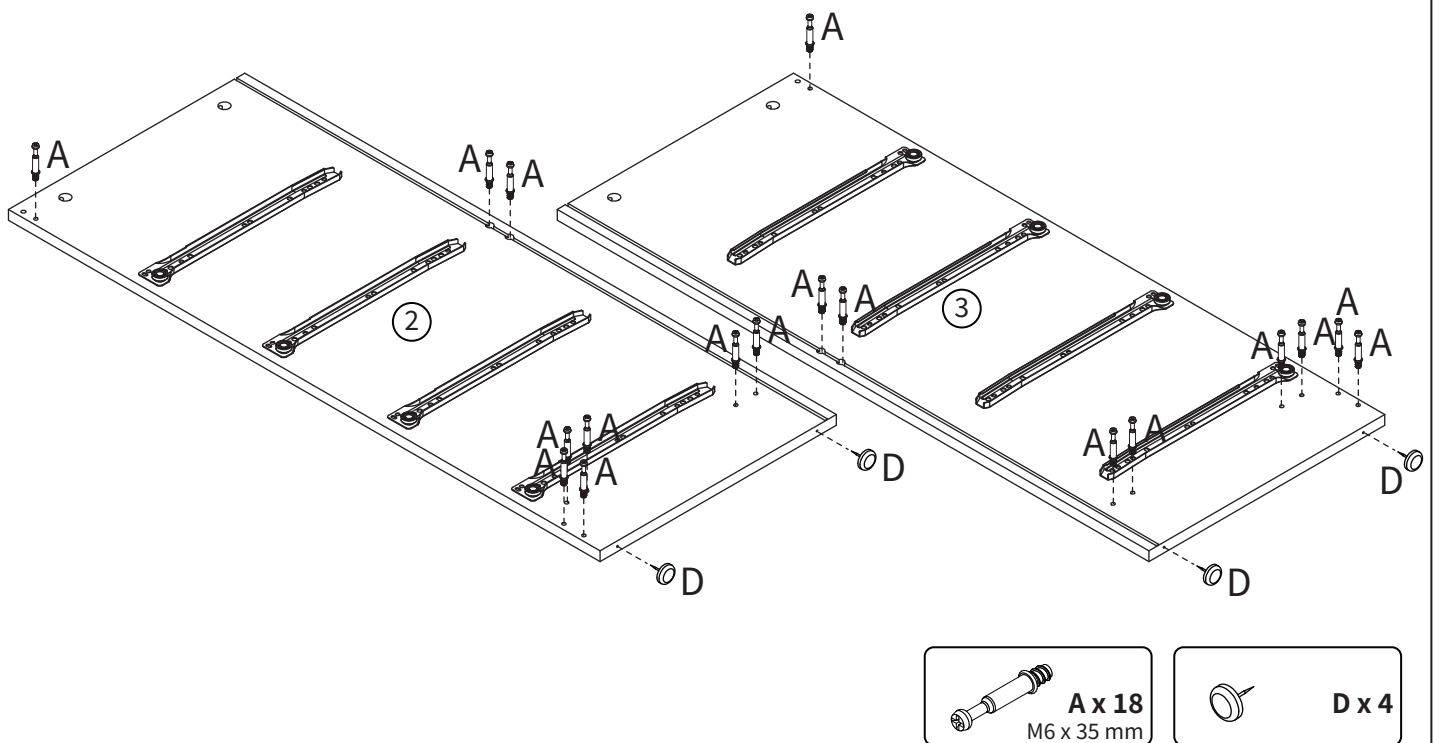

### Step 3

First lock the guide rail (**CL**) to the right side of the part ④ with the screw (**H**), then turn it 180 degrees and lock the guide rail (**CR**) to the left side of the part ④ with the screw (**H**), the installation position is as shown below.

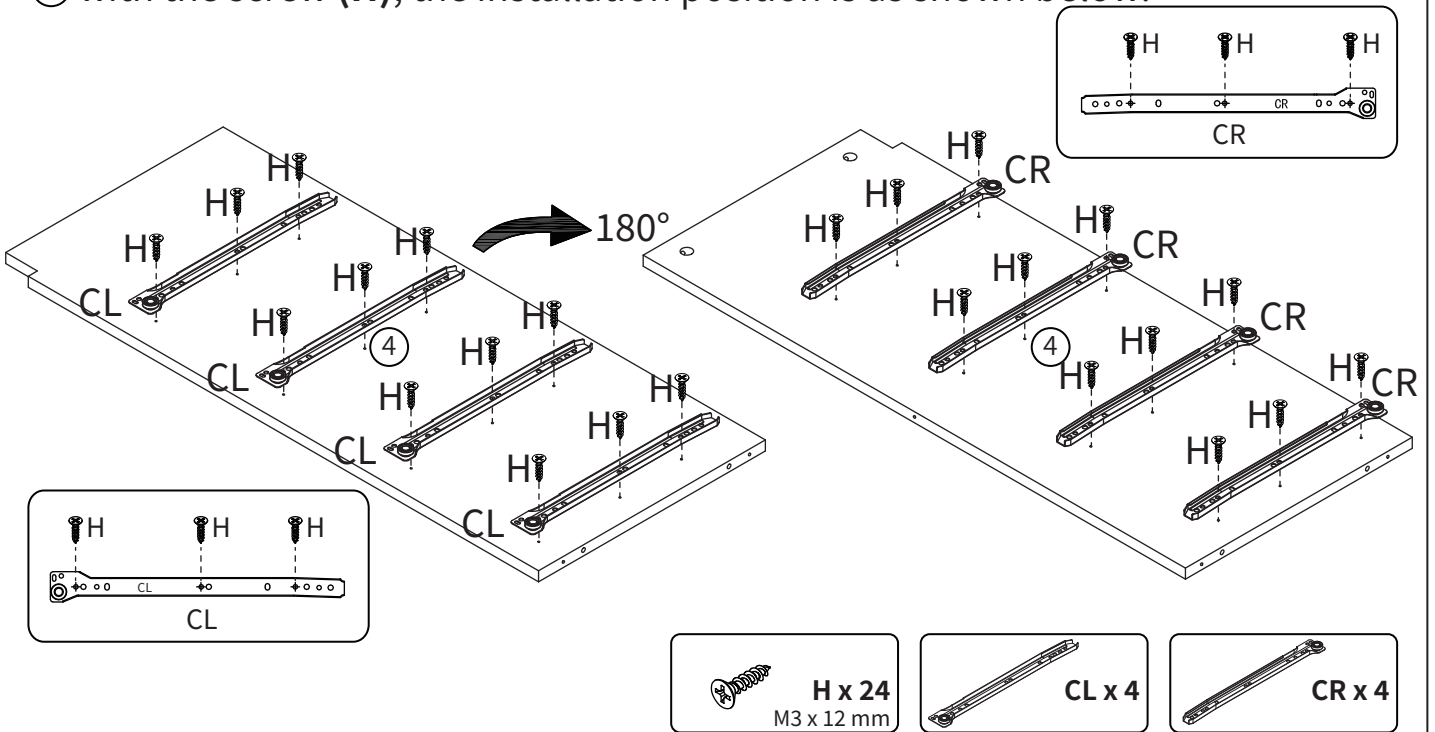

### Step 4

Use screw (**E**) to lock the part ④ and part ⑨. The installation position is as shown below.

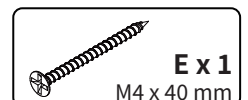
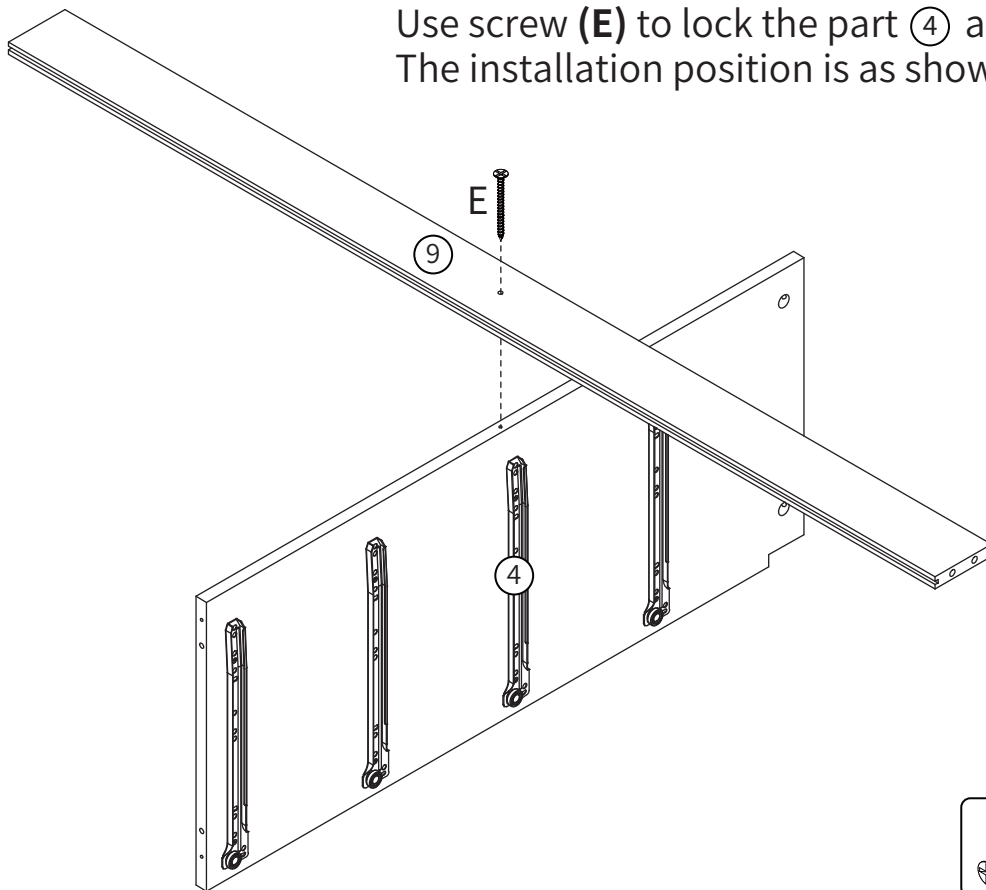

## Step 5

Lock screw **(A)** on the part ⑥, ⑧ and ⑪, then use screw **(E)** through the part ⑦ to lock the part ⑱, then screw on adjustment foot pad **(L)** on Part ⑱. The installation position is as shown in the figure below.

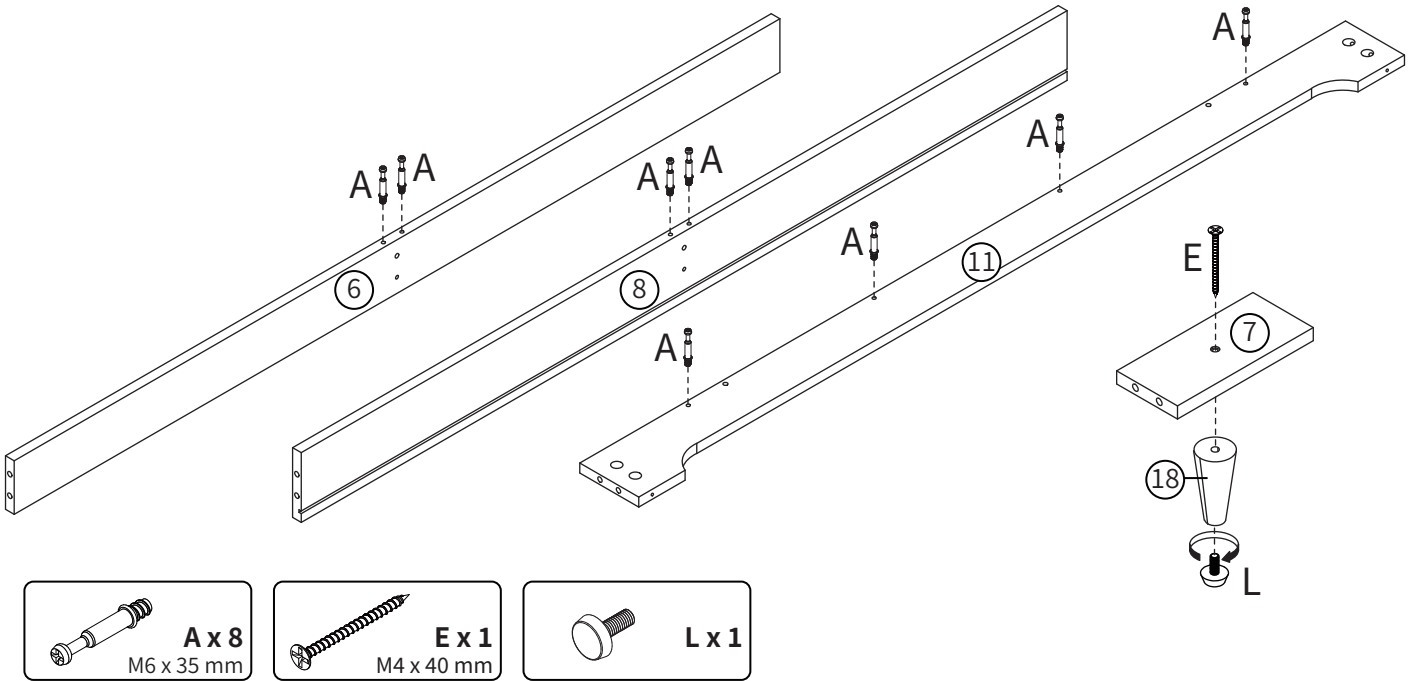

## Step 6

Insert the dowel **(C)** into part ⑥ first, Then assemble parts ⑥ and ⑪, put eccentric **(B)** into the corresponding hole, and tighten it with screw **(A)** by turning it clockwise with a screwdriver. Lock foot pad **(D)** on the part ⑪. The installation position is as shown below.

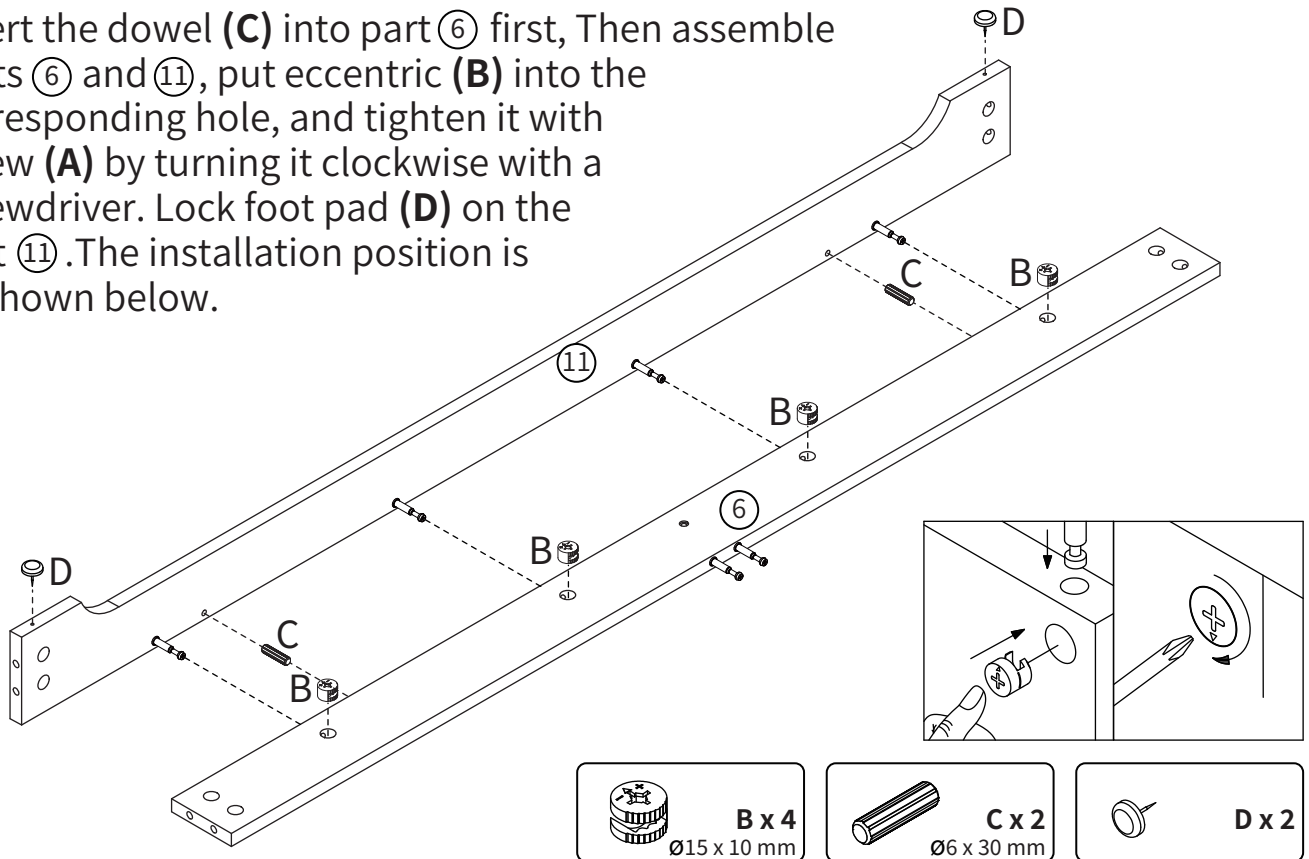

## Step 7

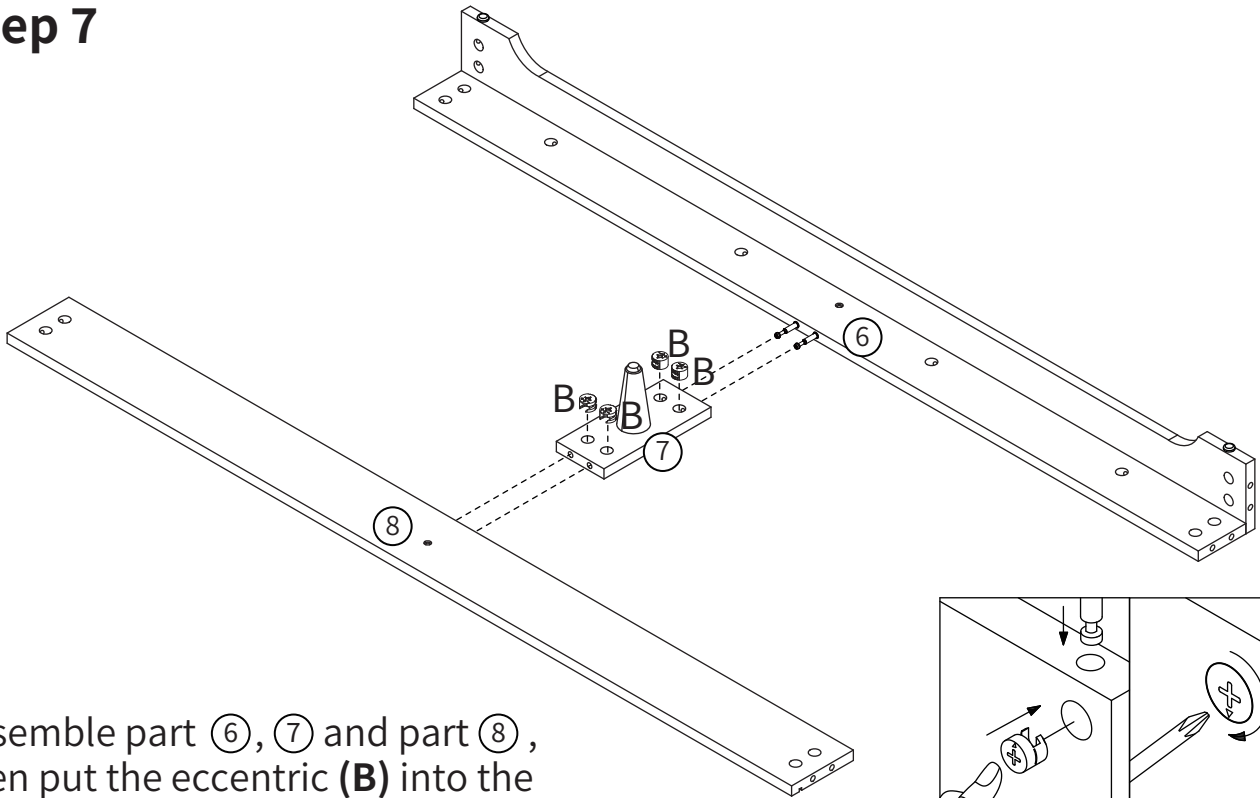

Assemble part ⑥, ⑦ and part ⑧, then put the eccentric (**B**) into the corresponding hole and use a screwdriver to turn it clockwise to tighten. The installation position is as shown below.

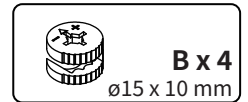

## Step 8

Insert the dowel (**C**) into part ④ first, then assemble part ④, ⑥ and part ⑧, then use screw (**E**) to lock the part ④, ⑥ and part ⑧. The installation position is as shown below.

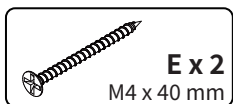
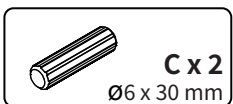
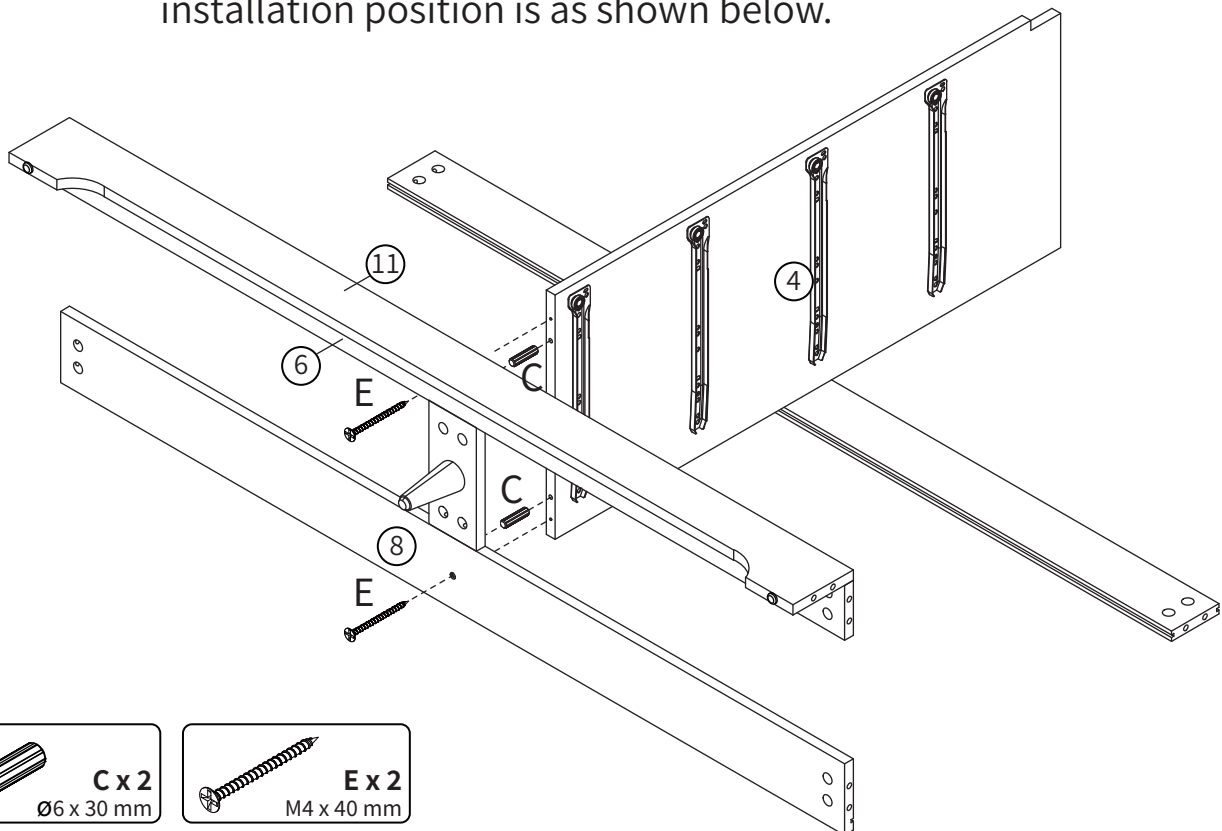

## Step 9

Insert the dowel (C) into part ② first, then assemble part ⑤, ⑥, ⑧, ⑨, ⑪, and part ②. Put the eccentric (B) into the corresponding hole and use a screwdriver to turn it clockwise to tighten. The installation position is as shown below.

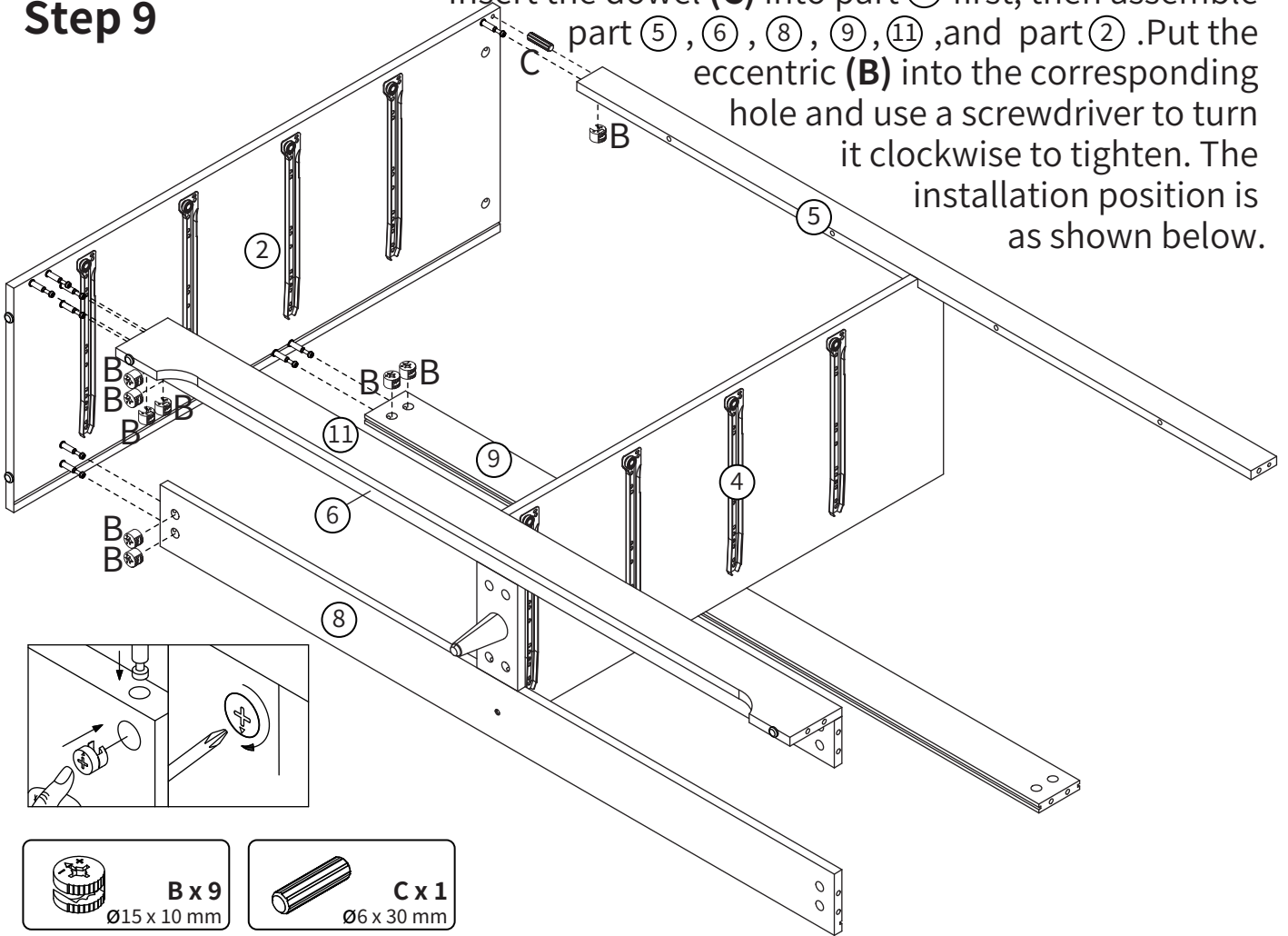

## Step 10

Insert the part ⑩ into the slots of the parts ⑧ and ⑨. The installation position is as shown below.

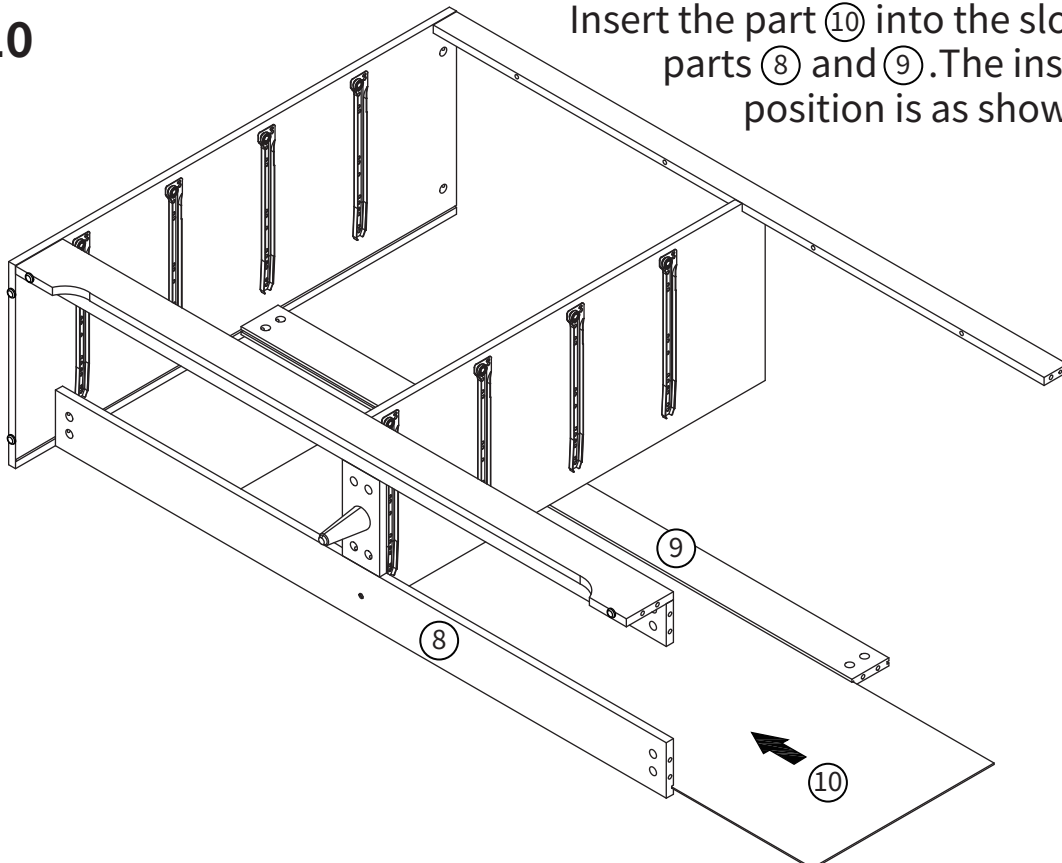

# Step 11

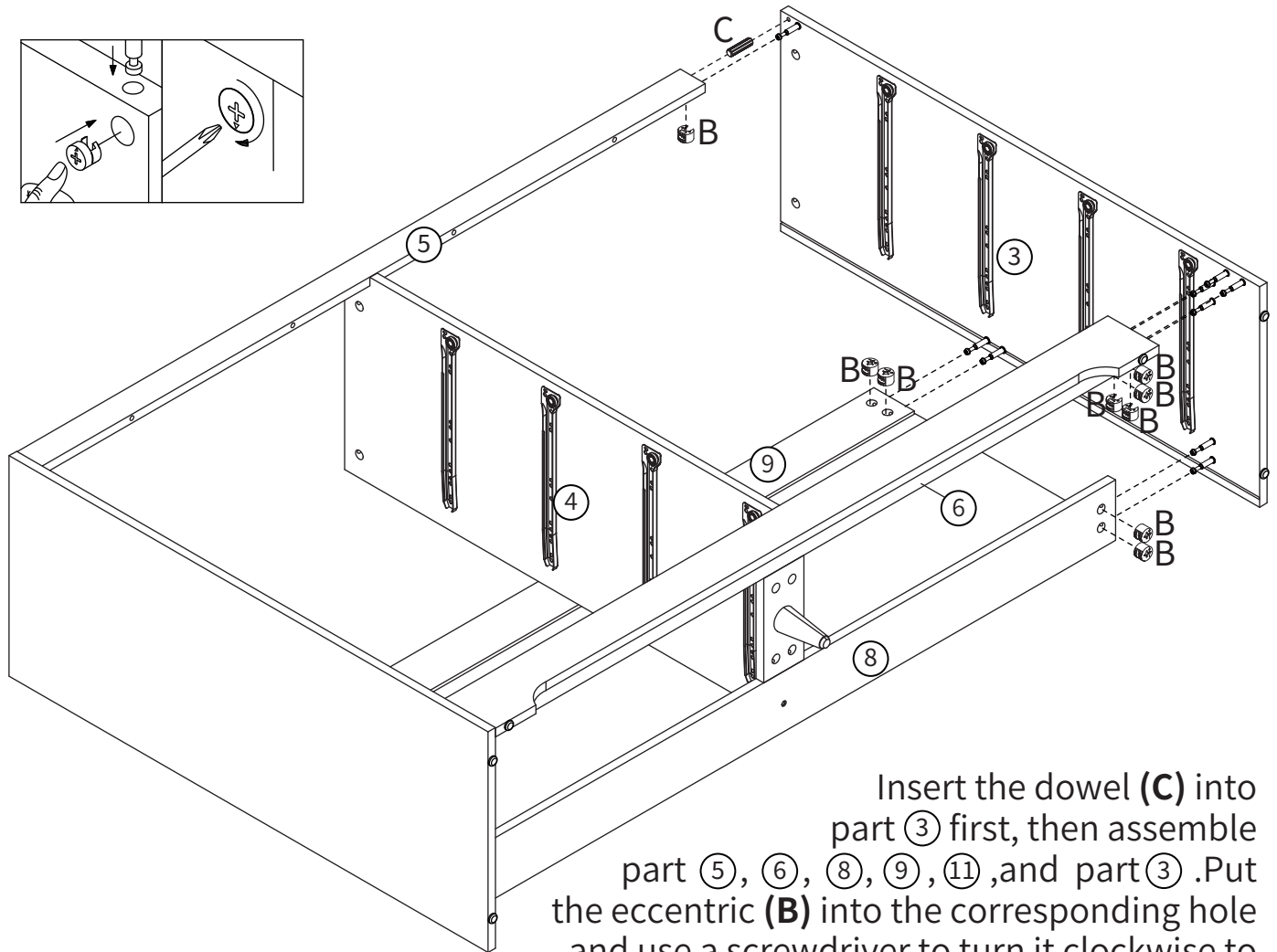
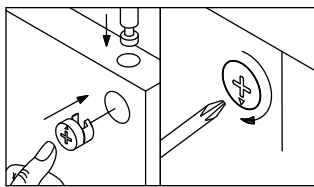

Insert the dowel (**C**) into part ③ first, then assemble part ⑤, ⑥, ⑧, ⑨, ⑪, and part ③. Put the eccentric (**B**) into the corresponding hole and use a screwdriver to turn it clockwise to tighten. The installation position is as shown below.

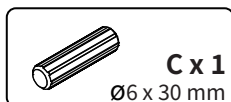

## Step 12

Insert the part ⑩ into the slots of the parts ② and ③. The installation position is as shown below.

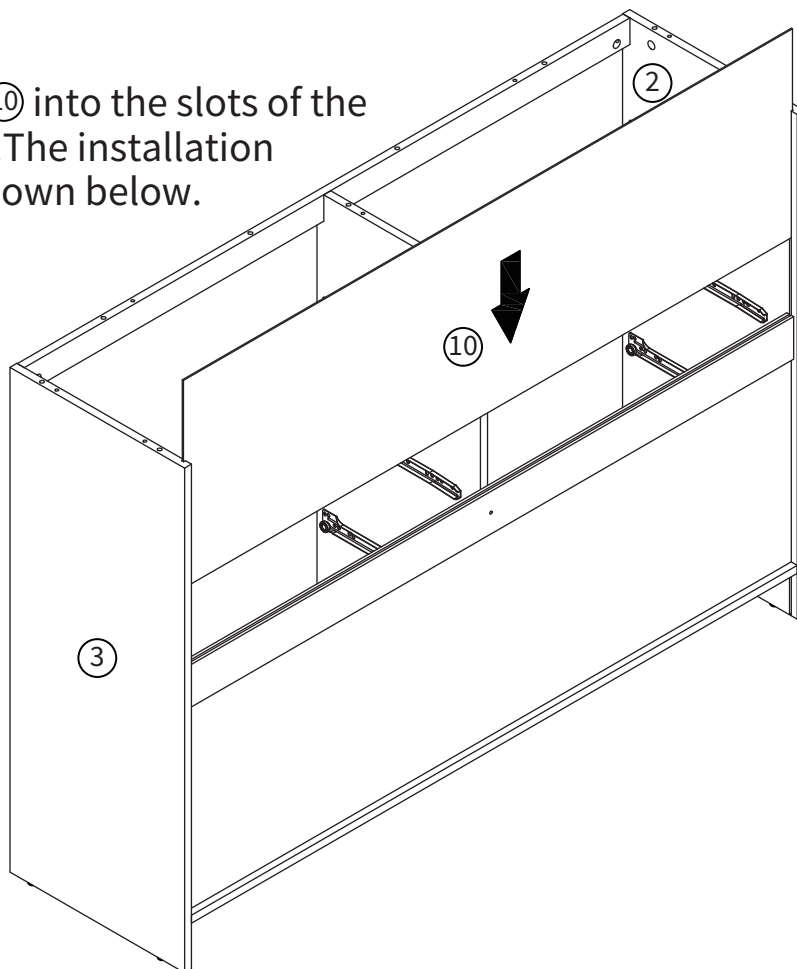

## Step 13

Lock screw (A) on the part ①.

The installation position is as shown in the figure below.

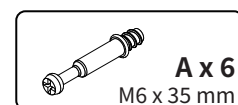
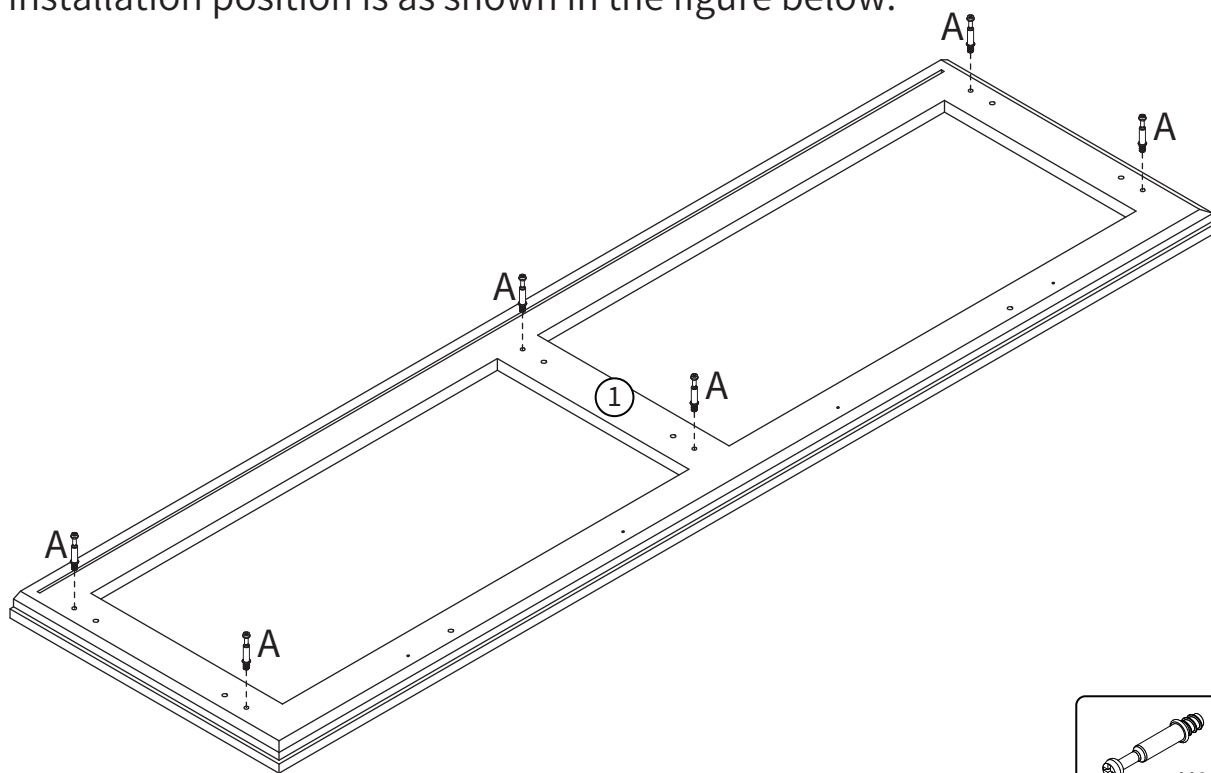

## Step 14

Insert the dowel (C) into part ②, ③, ④ and ⑤ first, then assemble part ②, ③, ④, ⑤ and part ①. Put the eccentric (B) into the corresponding hole and use a screwdriver to turn it clockwise to tighten. Use screw (E) to lock the part ⑤ with the part ①. Rotate the foot pad (L) to enable it to support the product. The installation position is as shown below.

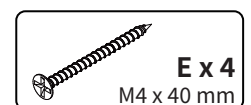
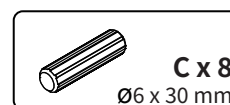
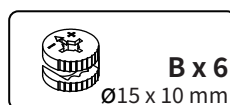
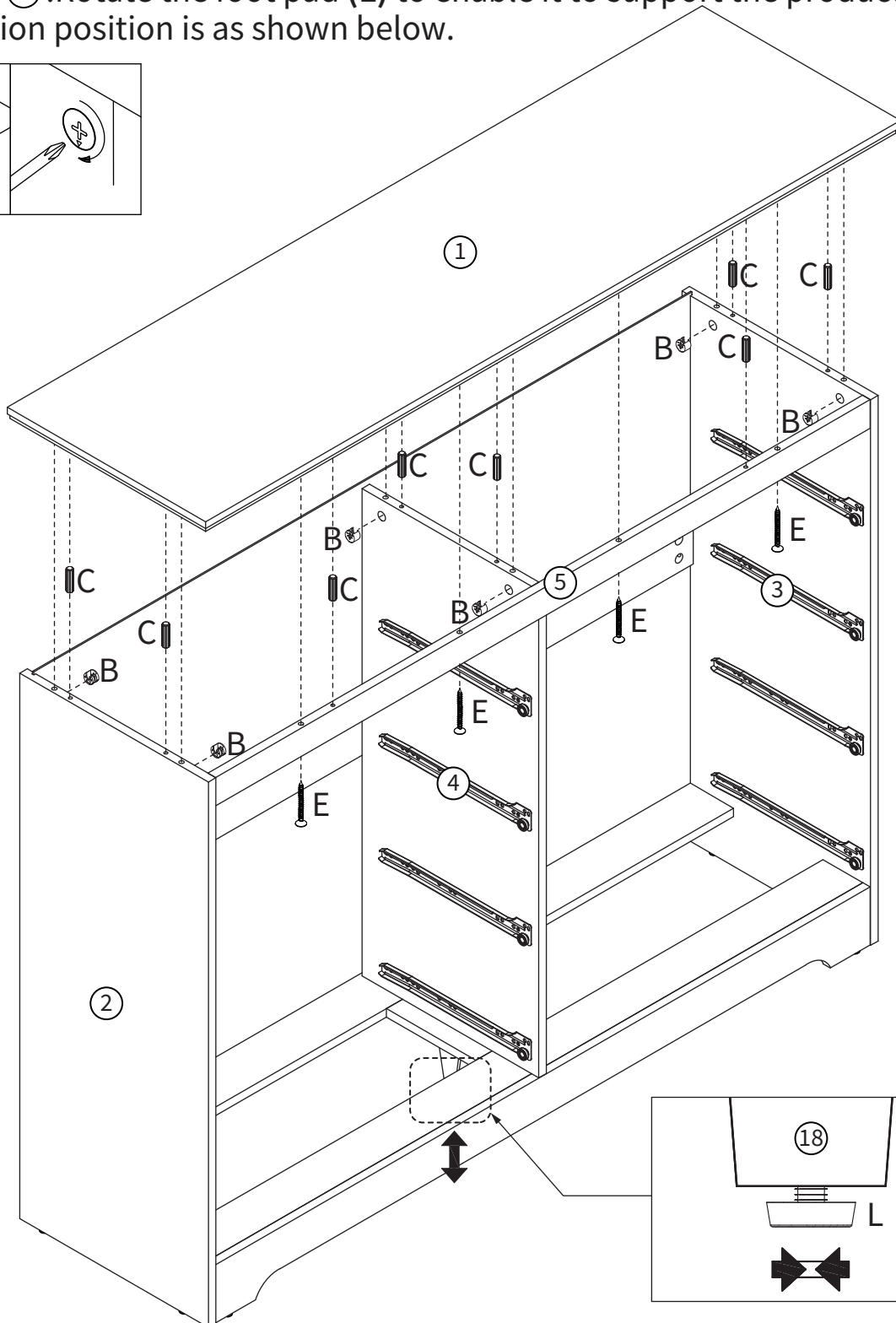
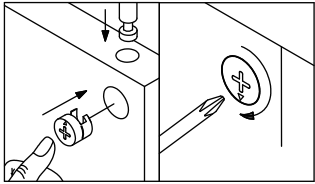

## Step 15

Lock screw (A) on the part ⑰.

And then use hardware (J) to lock the handle (K) on the part ⑰.

The installation position is as shown in the figure below.

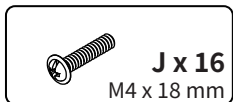
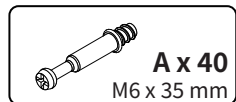
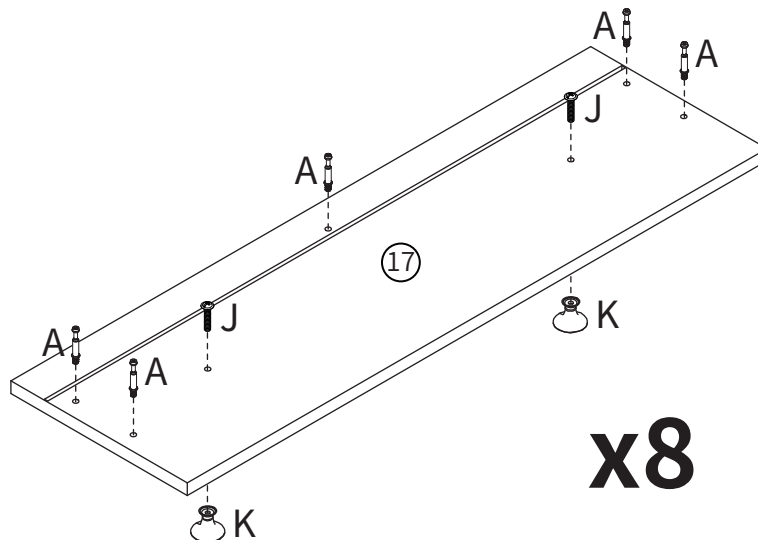

## Step 16

Use screw (F) to lock the part ⑫, ⑬, ⑭ and ⑮.

The installation position is as shown in the figure below.

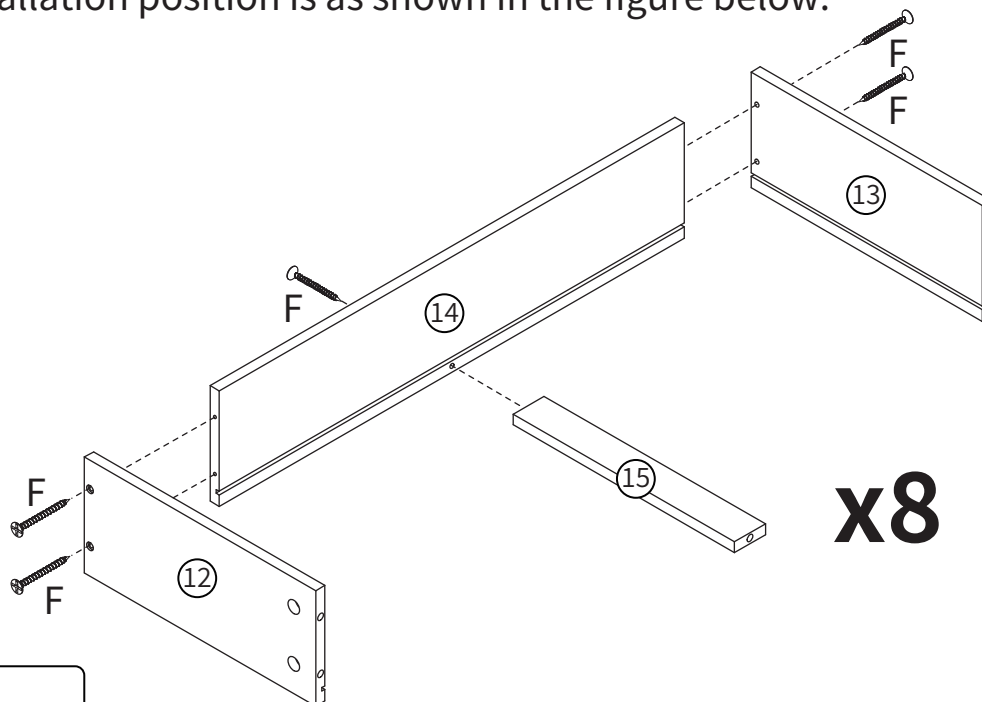

## Step 17

Insert the part ①⑥ into the slots of the part ①② and ①③.  
The installation position is as shown below.

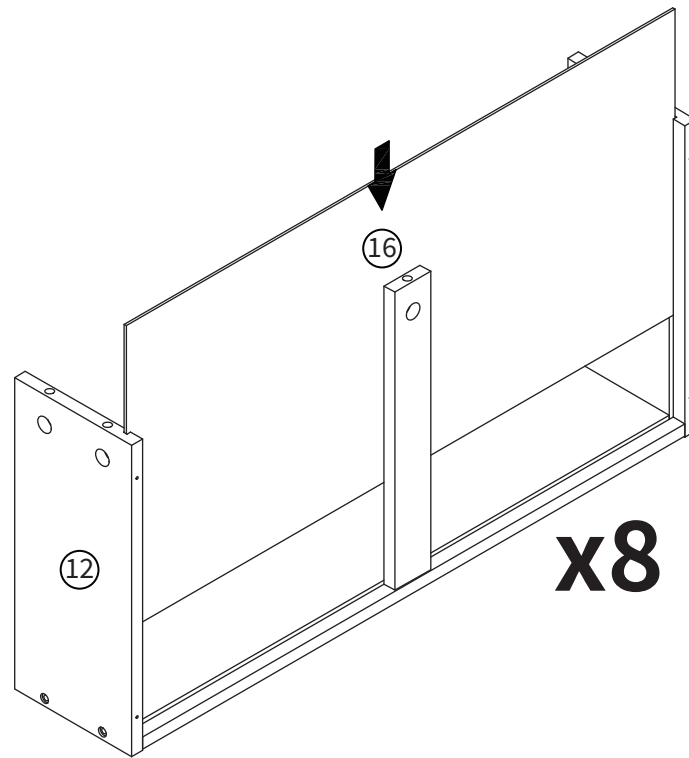

**Step 18** First use eccentric (**B**) to combine the part ①② and ①③ with the part ①⑤ and ①⑦ respectively. The installation position is as shown below.

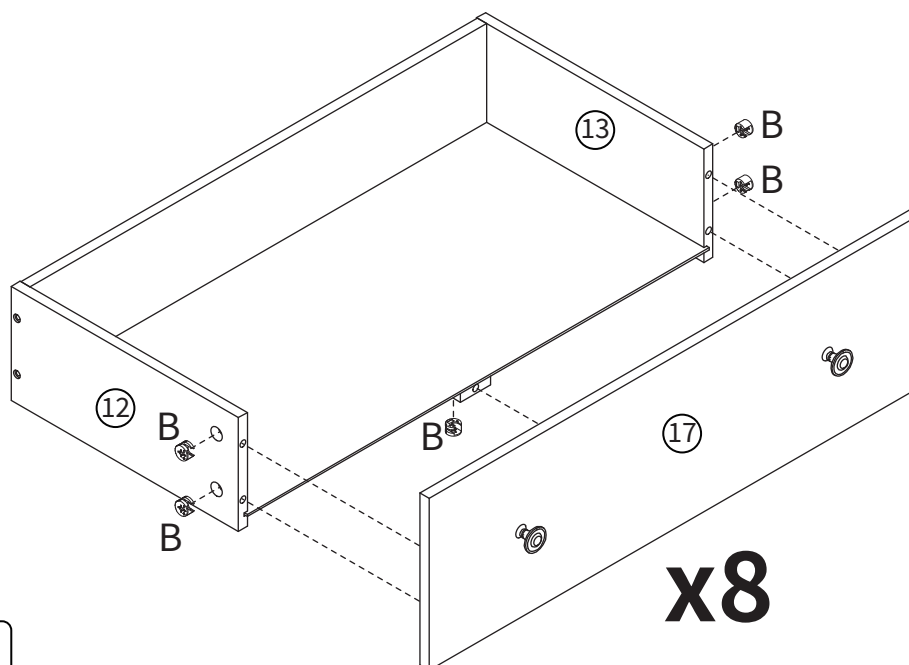

## Step 19

Use screws (**H**) to install the guide rail (**DL**) on the side panel **(12)**, and install the guide rail (**DR**) on the side panel **(13)**. Drawer total of 8 sets are required to be assembled. The installation position is as shown in the figure below.

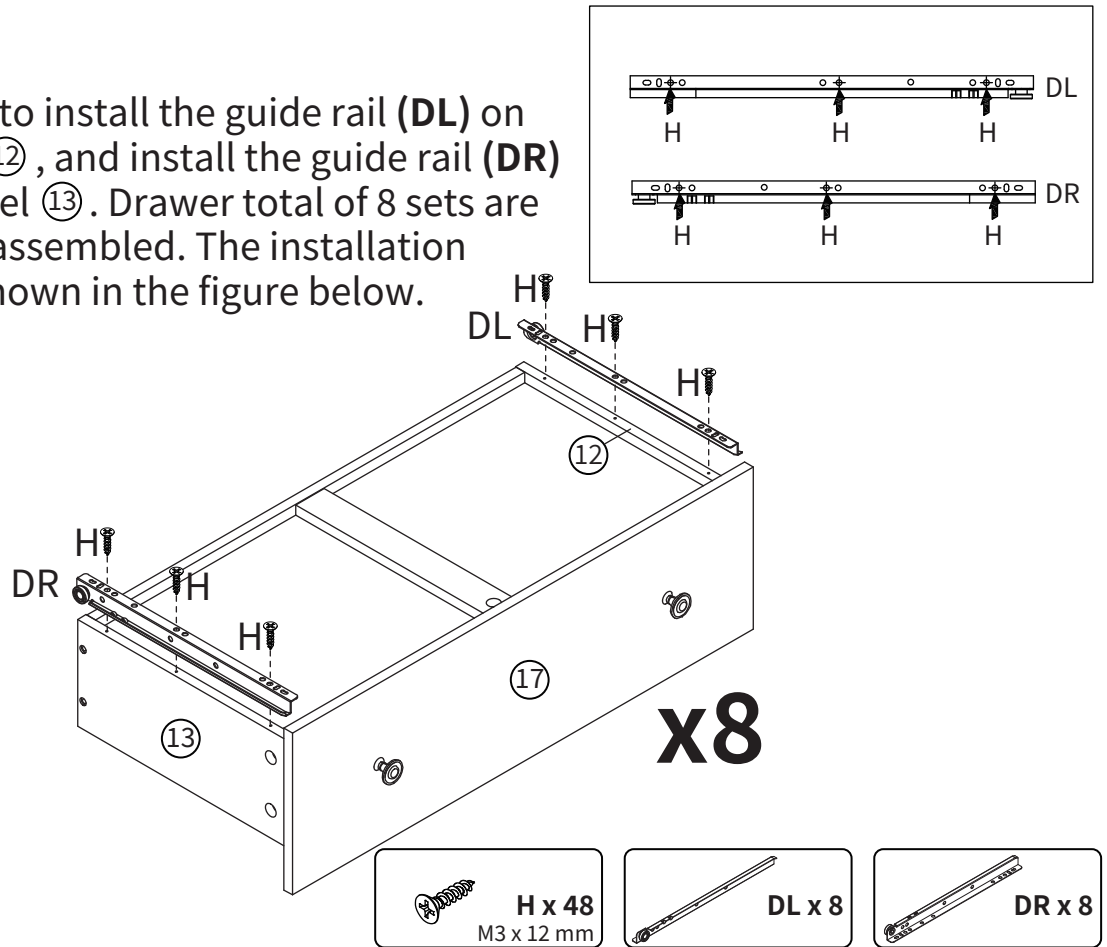

## Step 20

Place the drawer into the corresponding position, as shown in the figure.

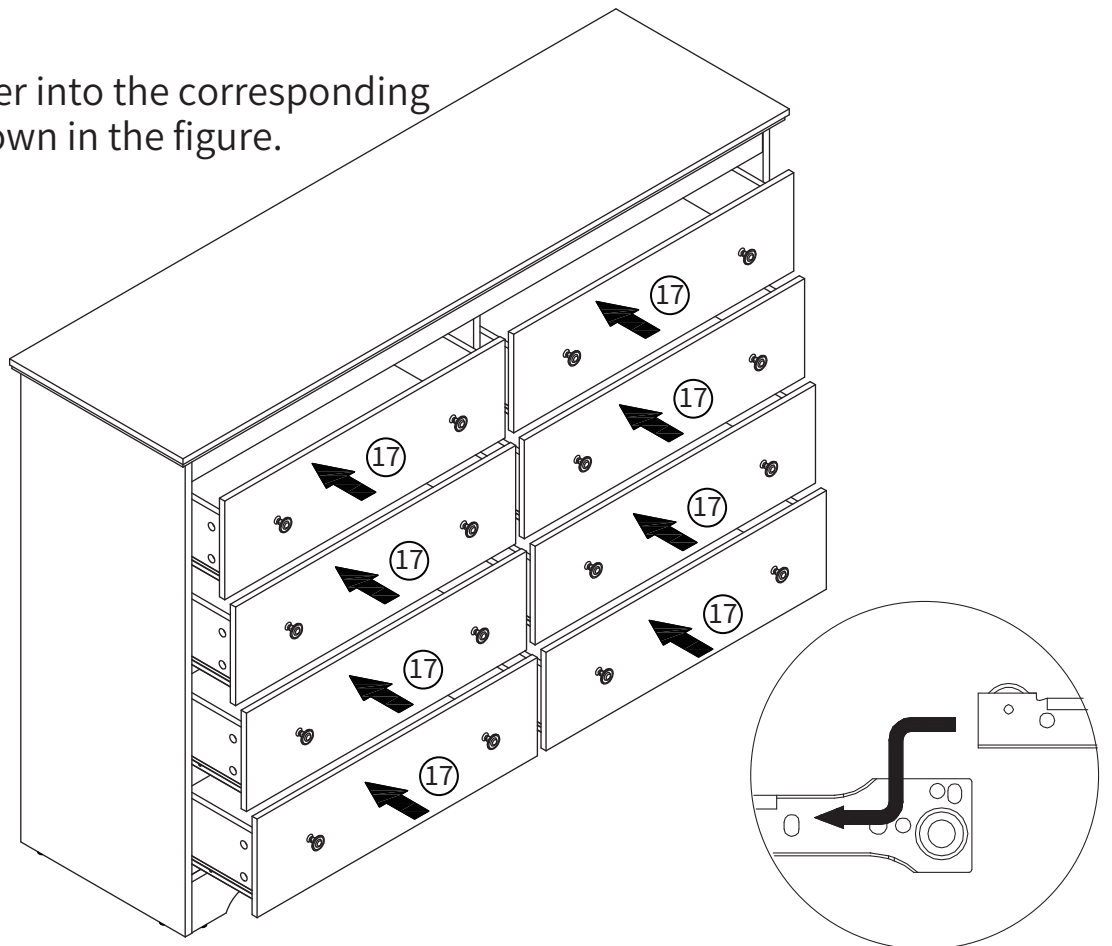

## Step 21

Use the small screws in the hardware bag (G) to lock the piece of iron to the part ①. Lock the backplane buckle (I) to the four corners of the backplane. The following figure shows the installation position.

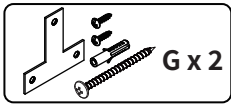
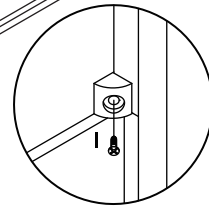
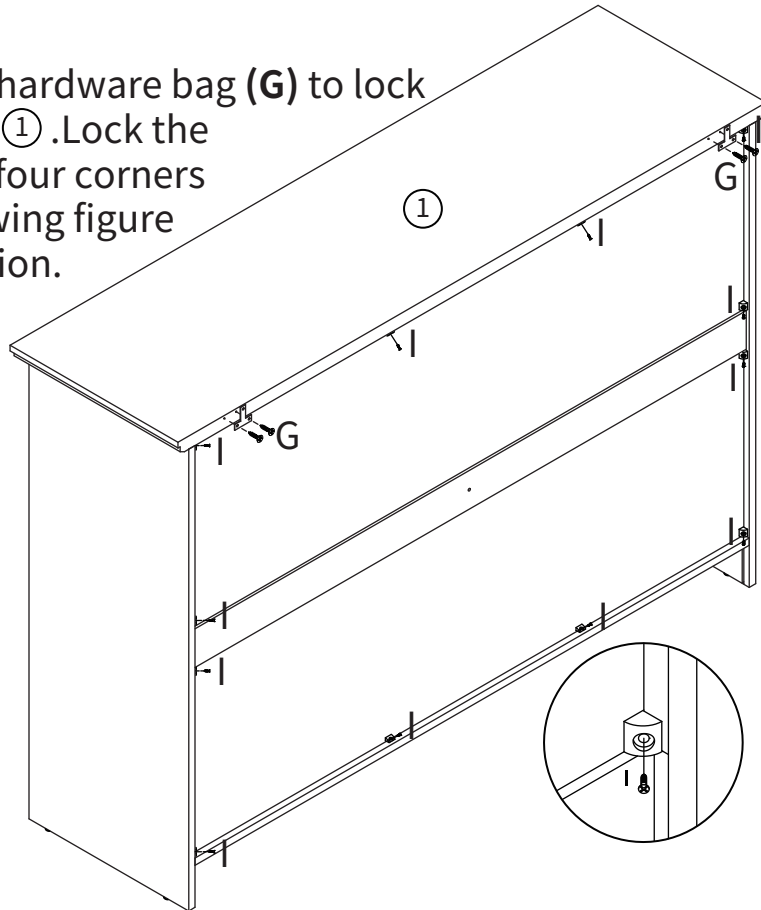
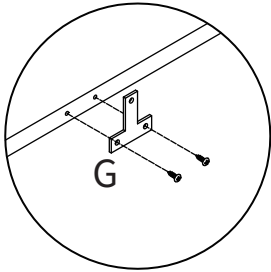

## Step 22

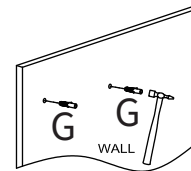
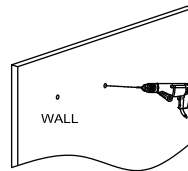
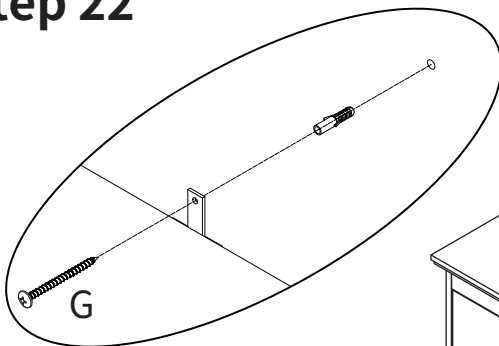

First knock the expansion screws in hardware (G) into the wall with a hammer, and then use the long screws in hardware (G) to pass through the iron sheet and lock into the expansion screws in the wall. The following figure shows the installation position.

