

## WARRANTY

We strive to offer high-quality products, and we also try our best to satisfy each and every customer that orders from us with product or service as needed.

Each customer must provide a record of their orders such as the order number, or item receipt for any items that are out of the warranty period. You may also still receive replacement parts by purchasing them without our company if they are available.

**Are you having difficulty  
with assembly? Missing parts?**

**Please contact us : [info@firstopinl.com](mailto:info@firstopinl.com)**

**telephone No.: 5627813327**

**send email with your order No. to**

**For return, please check the return policy with  
the retailer or market place you bought from.**

**Appreciate your purchasing from us.**

**Pop up your life by your furniture!**

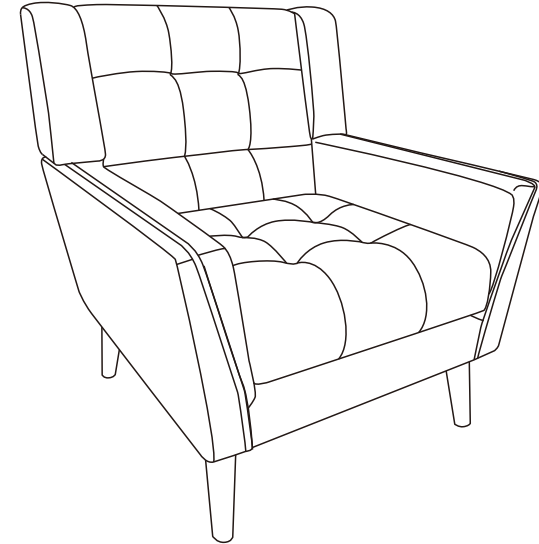
The logo for Wixe, featuring the word "wixe" in a bold, lowercase, sans-serif font. The letter "i" is stylized with a grey dot and a grey vertical bar.

**ITEM NO. CH0034**

---

### NOTE:

This brochure contains IMPORTANT safety info. Please read and keep for future reference.

---

# MAINTAINANCE AND WARNING

- Keep furniture away from heat and fire.
- Keep furniture away from sharp objects.
- Do not clean furniture with harsh cleansers or polish. Do not use detergents, Solvents, abrasives, spray packs or leather cleaner. Use non-color mild soap with warm water clean spills(Mix 1:10 soap to water)
- Do not place furniture under direct sunlight, material will possibly fade over time.
- Do not jump or strike on the furniture.
- Do not write on furniture without a padded barrier to protect the surface.
- Not for commercial use, For residential use only.



Weight Limitation

**400LBS**

# PARTS LIST

A\*1

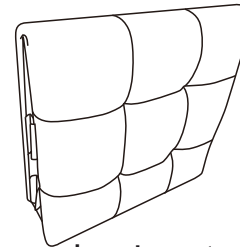

backrest

B\*1

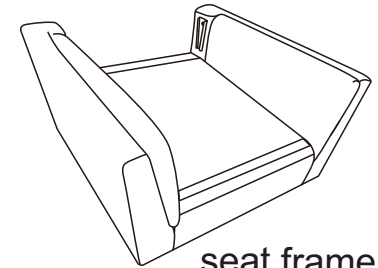

seat frame

C\*1



backrest ear

D\*1

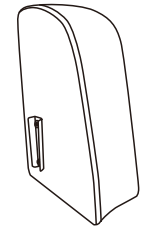

backrest ear

E\*1

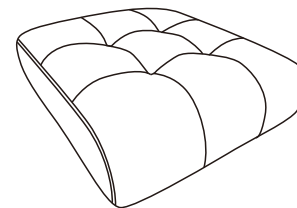

seat cushion

F\*4



wood legs

# HARDWARE and TOOL LIST

①\*12  
M6\*20mm



Bolt

②\*1

M6



Allen Key

## SPARE

①\*2  
M6\*20mm



Bolt

Be sure to check all packing material fit the packing list. Carefully for small parts, which may have come loose inside the carton during shipment.

# ASSEMBLY INSTRUCTIONS

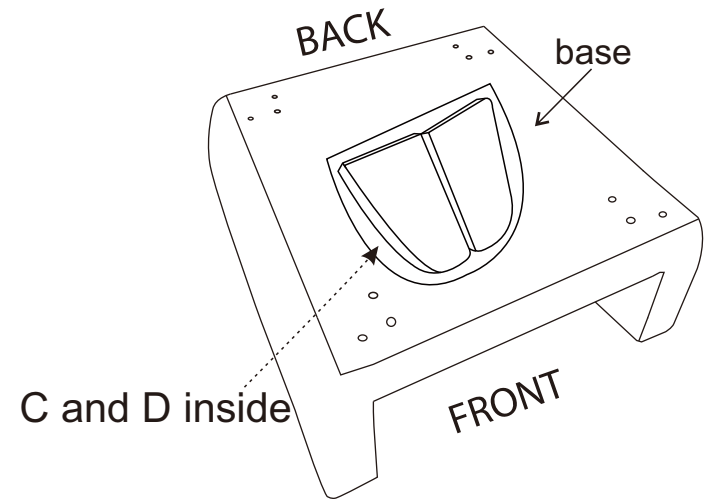

**STEP 1:** Turn the seat frame B upside down on clean padded surface, carefully take the backrest ear C and D out from the bottom space of seat.

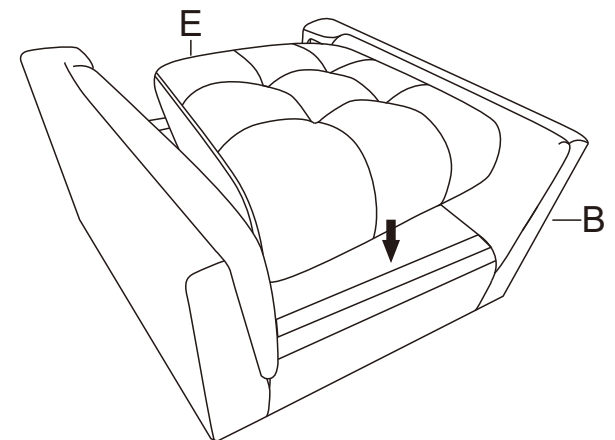

**STEP 2:** Put the seat cushion E on the Seat Frame B.

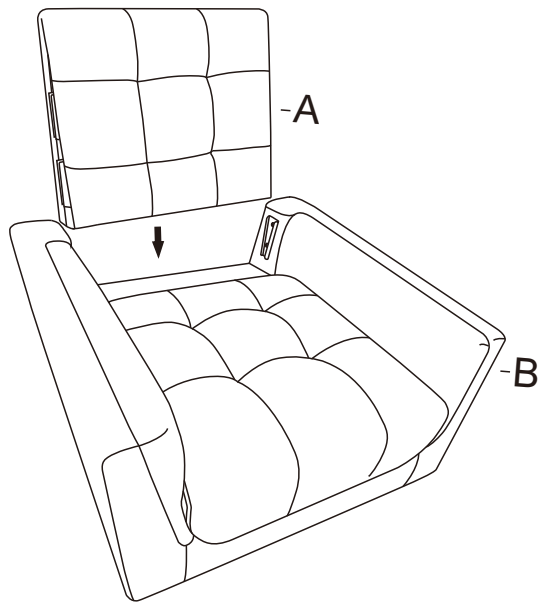

**STEP 3:** Turn the the chair base assembly upright carefully align male and female metal brackets on both sides then push the backrest A all the way down to secure.

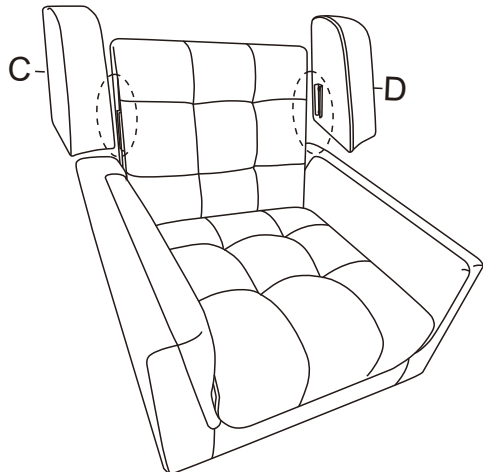

**STEP 4:** Carefully align male and female metal brackets on both sides then push backrest ears C and D all the way down to secure.

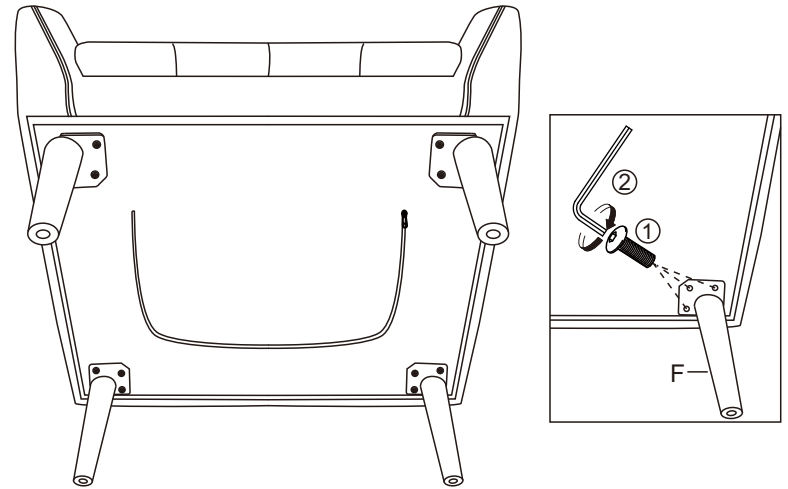

**STEP 5:** Put all bolts in the hole on legs F, use allen key to tighten one by one.

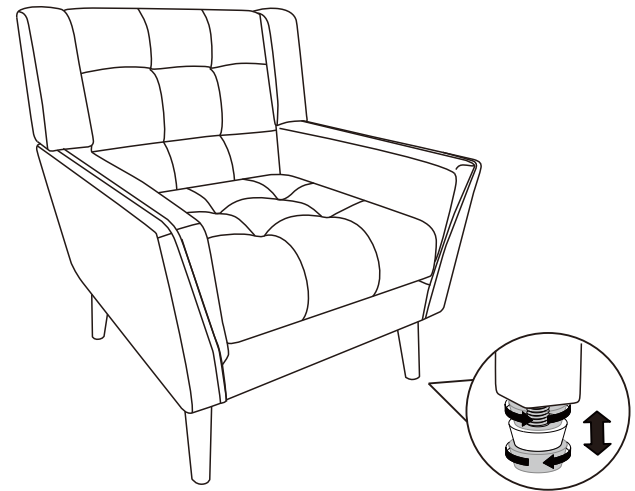

**STEP 6:** Assembly completed.