

# IVAN

## ASSEMBLY GUIDE

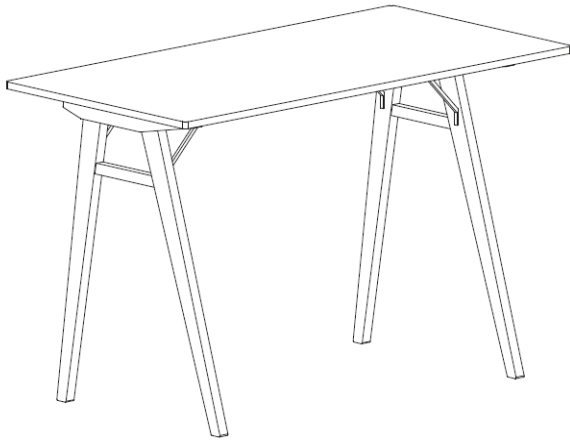

**Important - Please read these instructions fully before starting assembly**



**SAFETY AND  
CARE ADVICE**



**NO POWER TOOLS**

**SAFETY AND CARE ADVICE**

- Check you have all the components and tools listed.
- Remove all fittings from the plastic bags and separate them into their groups.
- We do not recommend the use of power drills/drivers for inserting screws, as this could damage the unit. Only use hand screwdrivers and Allen keys.
- Keep children and animals away from the work area, small parts could cause choking if swallowed.
- Make sure you have enough space to lay out the parts before starting.
- Assemble the item as close to its final position (in the same room) as possible.
- Do not over tighten the nuts to avoid causing damage to the threads.
- Only clean using a damp cloth and mild detergent, do not use bleach or abrasive cleaners.
- From time to time check that there are no loose screws on this unit
- This product should not be discarded with household waste. Take to your local authority waste disposal centre

# IMPORTANT INFORMATION



30 MINUTE  
BUILD



ONE  
PERSON



MAXIMUM  
CAPACITY 30Kg

PLEASE CHECK CAREFULLY AND MAKE SURE YOU HAVE ALL FITTINGS AND TOOLS LISTED BELOW BEFORE YOU START.

 x8 j38	 x8 g26	 x8 Ø4x16 mm p3	 x4 φ3.5x35 mm p70	 x1 z1
--	--	---	--	---

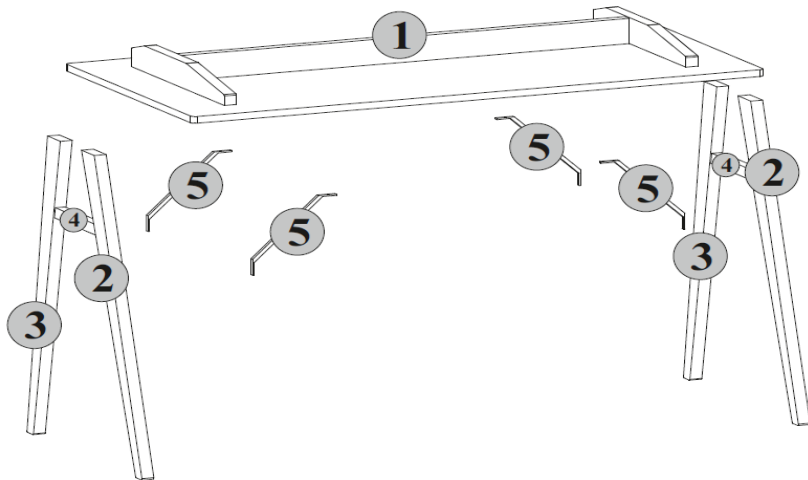

**NOTE:** The quantities above are the correct amount to complete the assembly. In some cases more fittings may be supplied than are required.

## STEP

Use a clean, flat, soft surface to avoid any bumps or scratches. Connect front and back legs [2 & 3] together with support [4] - secure with 2x screws [p70] and tighten with screwdriver. Repeat with 2nd pair of legs.

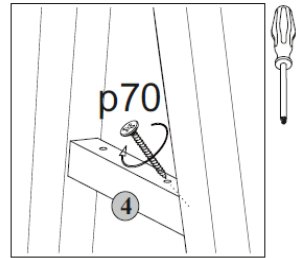
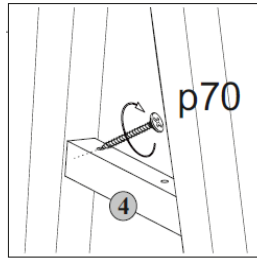
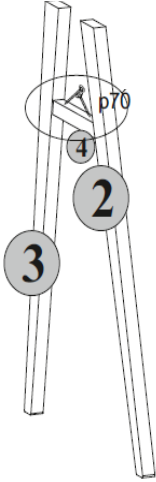

## STEP 2

Attach the legs to the table top. Place your table top upside down on a flat soft surface. Align legs with pre-drilled holes in the table frame and secure with 2x washers [g26] + 2x bolts [j56] on each leg-top (8 of each in total). Tighten with Allen key [z1].

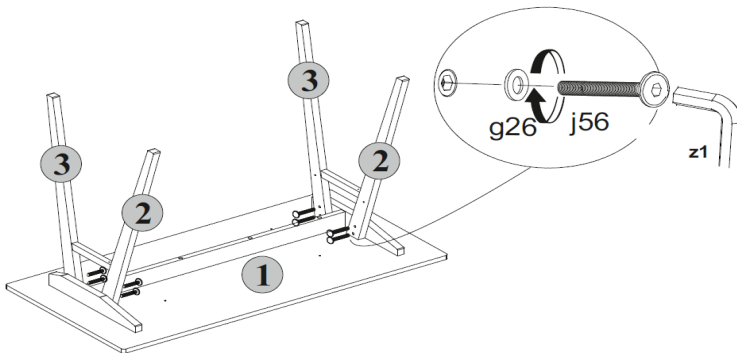

### STEP 3

Add leg support braces [5] on each leg. Align the pre-drilled holes and secure with 1x screw [p3] on either end - 8 in total. Tighten with screwdriver.

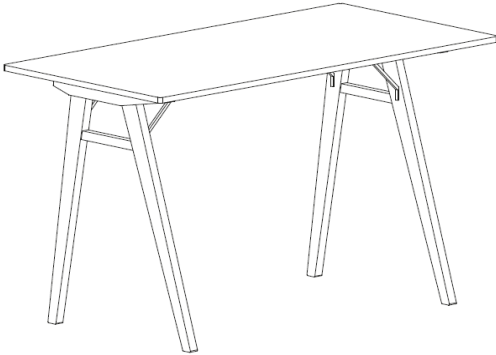
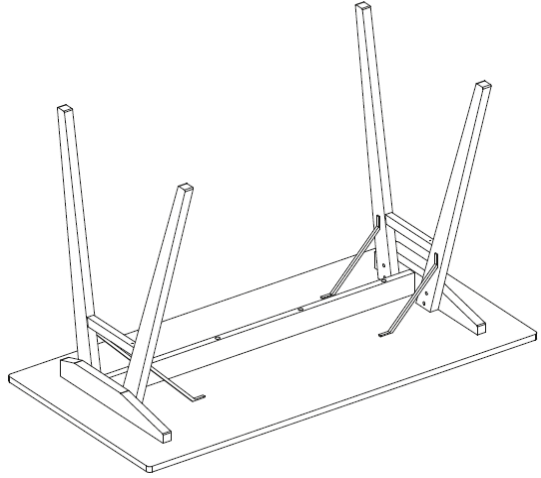
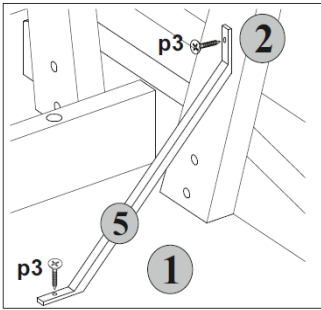

### STEP 4

Carefully, and with help, flip your table so it stands on its feet. Check stability. Your table is now ready to use!



# WE **L**OVE INTERIORS! SHARE YOURS WITH US ON SOCIAL MEDIA

1. follow us on Instagram
2. post your interior
3. tag us to be featured

# LOOKING GOOD!

Now you've assembled your product find out how to care for your item and keep it looking brand new.





## OUR 2 YEAR\* GUARANTEE

our products come with a 2 year guarantee to give you peace of mind shopping at

\*excludes some garden furniture items which have a 1 year guarantee



## WHAT THE GUARANTEE COVERS

---



**PRE-INSERTED FIXINGS**  
e.g. lose metal threads



**FAULTY JOINTS**  
e.g. legs bending



**EXTERNAL FIXING FAULTS**  
e.g. bonding/glue



**STRUCTURAL INTEGRITY**  
e.g. the frame of the product