

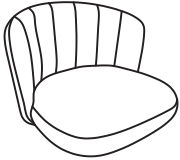



ASSEMBLY INSTRUCTIONS

Ax1	Fx16
	 M6*18mm
Bx1	Gx4
	 M6*25mm
Cx1	Hx1
	
Dx1	
	
Ex4	
	

1

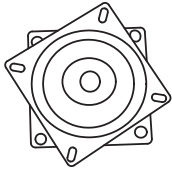

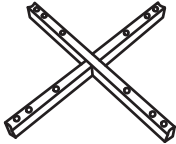
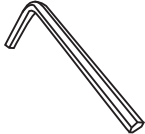
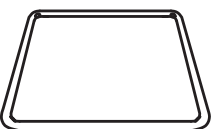
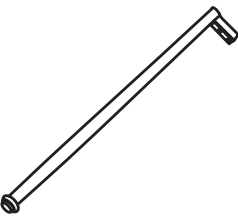
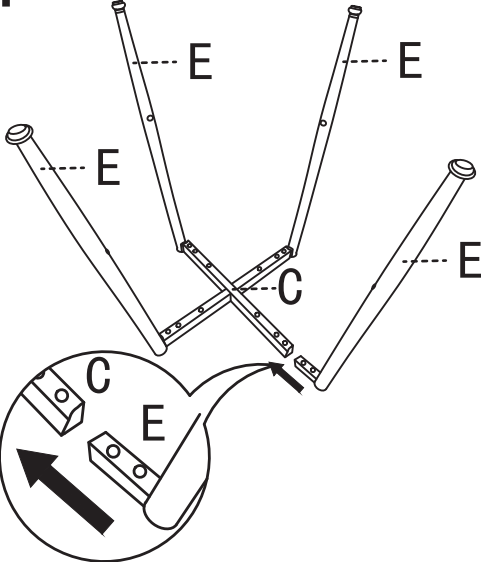
Insert (E) into (C) to connect them.

2

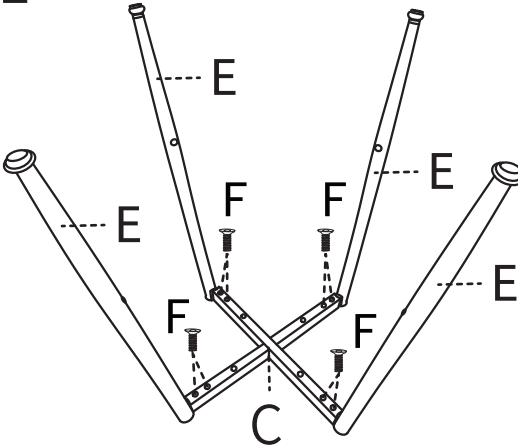

Fx8

M6*18mm

Pass (F) through the holes of (C) and screw it into (E) to secure (C) and (E).

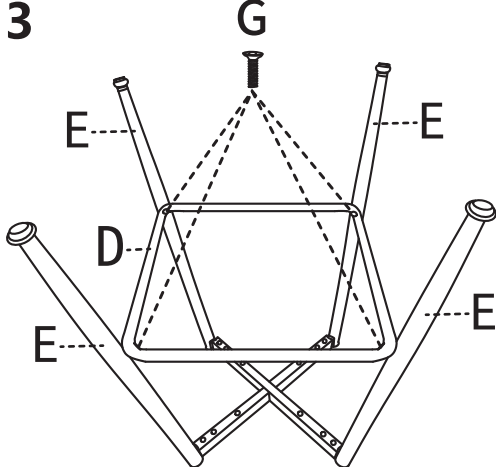
3



Gx4

M6*25mm

Align (D) with the holes on (E) as shown. Pass (G) through the holes of (D) and screw it into (E) to attach (D) to (E).

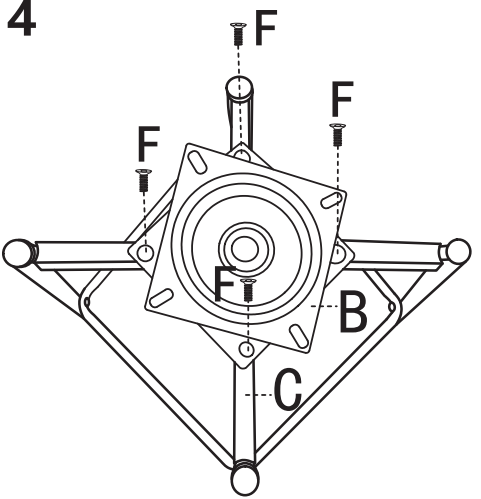
4



Fx4

M6*18mm

Flip the assembly so (C) is facing up. Place (B) as shown and screw (F) to attach (B) to (C).

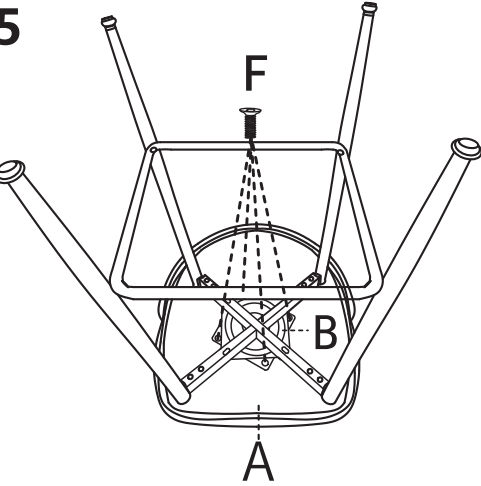
5



Fx4

M6*18mm

Align the holes at the bottom of (A) with the remaining holes of (B). Pass (F) through the holes of (B) and screw it into (A) to secure them.

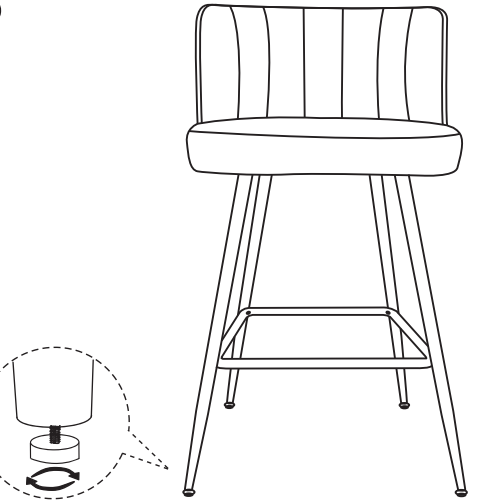
6



If you feel that the chair is leaning to one side due to uneven ground, rotate the foot pads to adjust it.

If there are any questions during the assembly process, please contact us
An video and description about the step you were stucked will help us to understand the problem quickly.