

ASSEMBLY INSTRUCTION

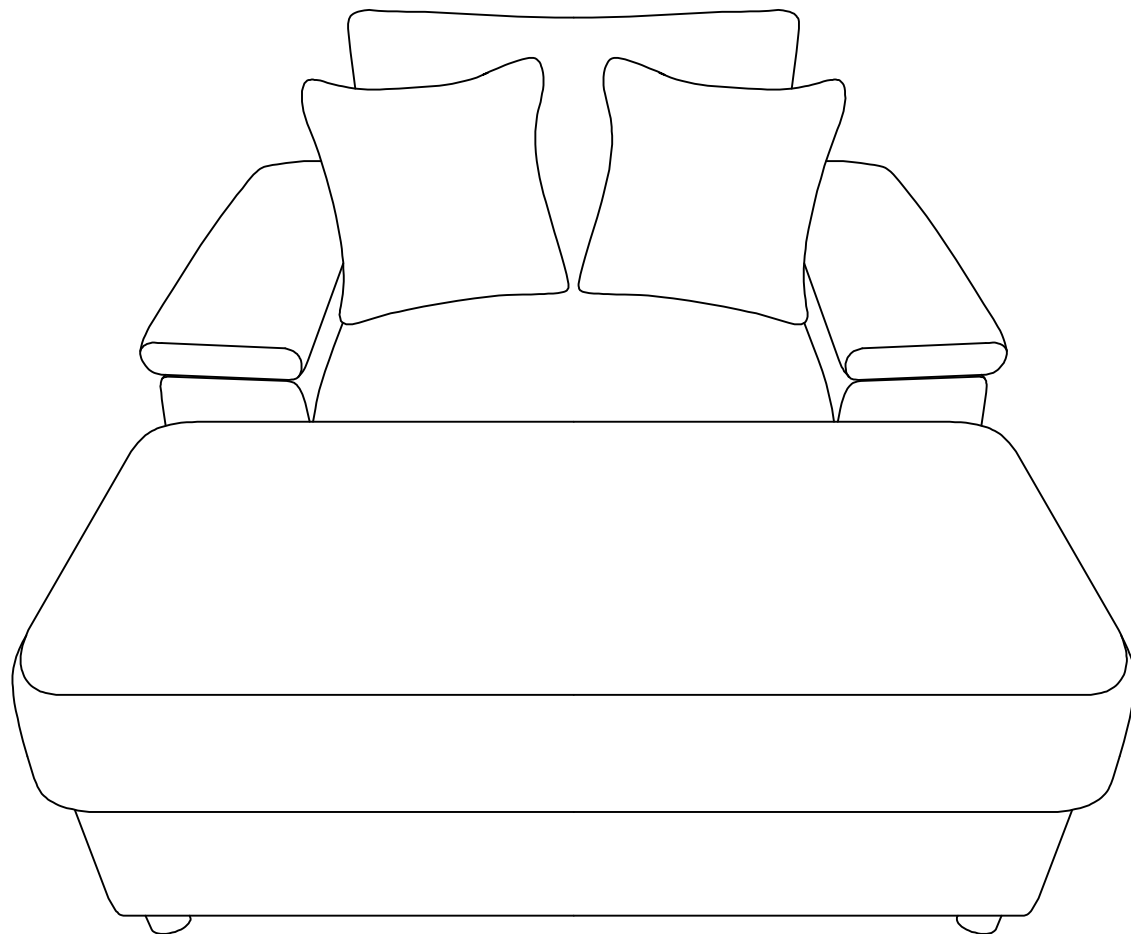

ASSEMBLY INSTRUCTION

Part list:

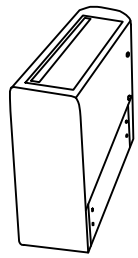

A:1pc

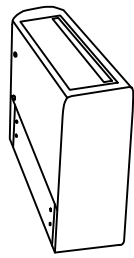

B:1pc

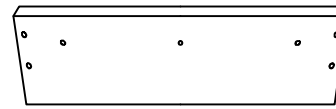

C:2pcs

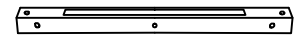

D:2pcs

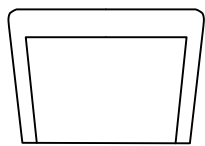

E:1pc

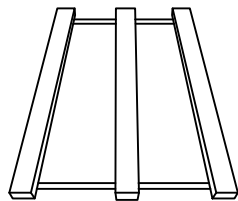

F:1pc



G:2pcs

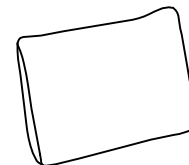

H:1pc

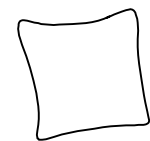

I:2pcs

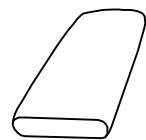

J:2pcs

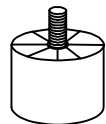

K:8pcs

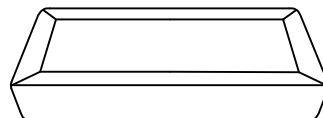

L:1pc

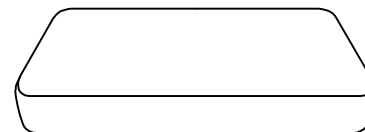

M:1pc

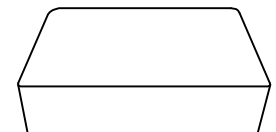

Z:1pc

Hardware list:



**M8*20mm
N:8pcs**



**M8*35mm
O:8pcs**



**M6*40mm
P:6pcs**

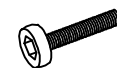

**M8*50mm
Q:4pcs**



**M6*55mm
R:4pcs**

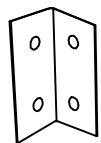

S:4pcs



**M6*16mm
T:14pcs**



**M8*19mm
U:20pcs**

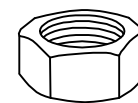

**M6
V:4pcs**

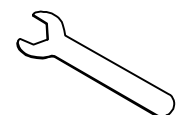

**M6
W:1pc**

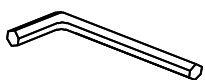

**M6
X:1pc**

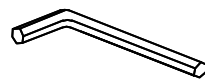

**M8
Y:1pc**

Step 1:

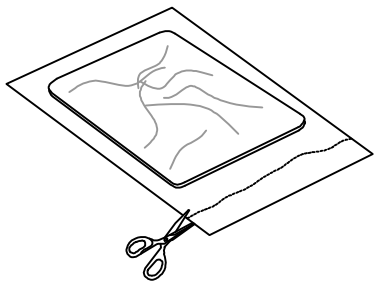

HX1



HX1

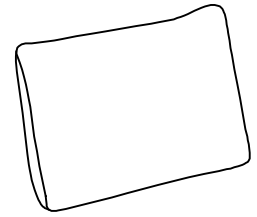

HX1

Please wait for 72 hours

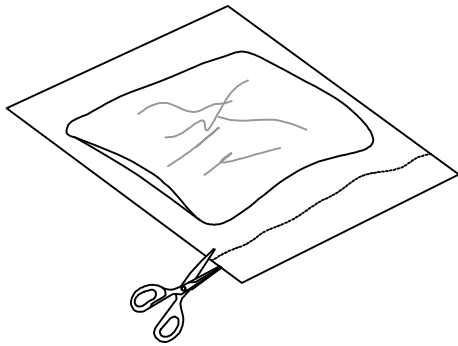

IX2

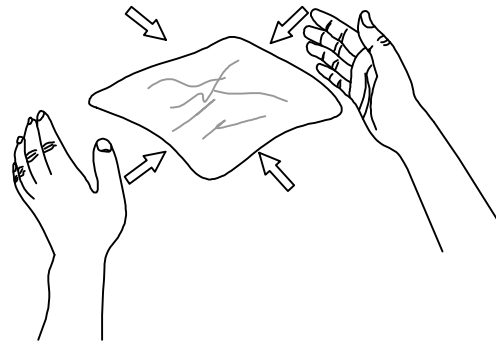

IX2

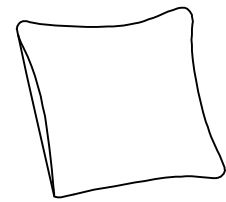

IX2

Please wait for 72 hours

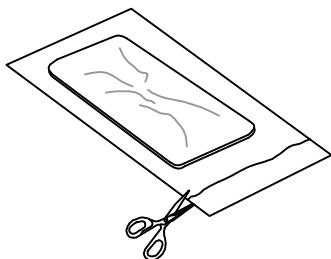

JX2

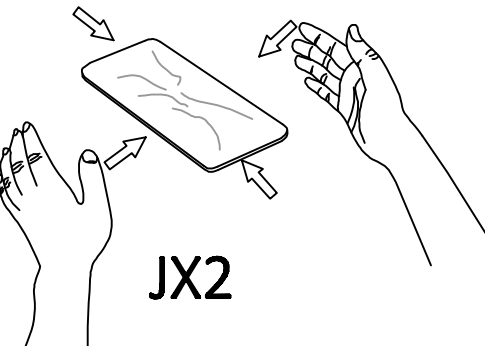

JX2

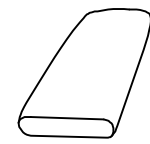

JX2

Please wait for 72 hours

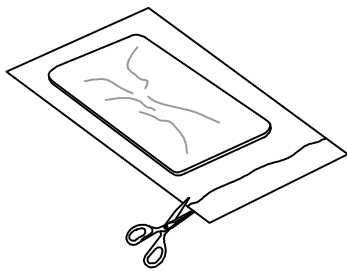

MX1

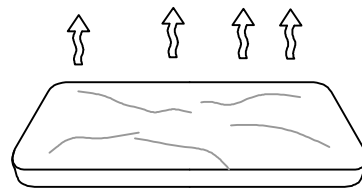

MX1

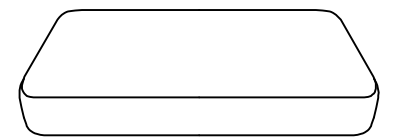

MX1

Please wait for 72 hours

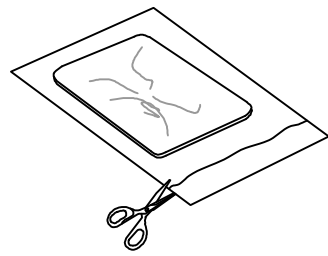

ZX1

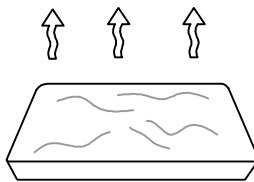

ZX1

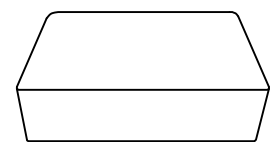

ZX1

Please wait for 72 hours

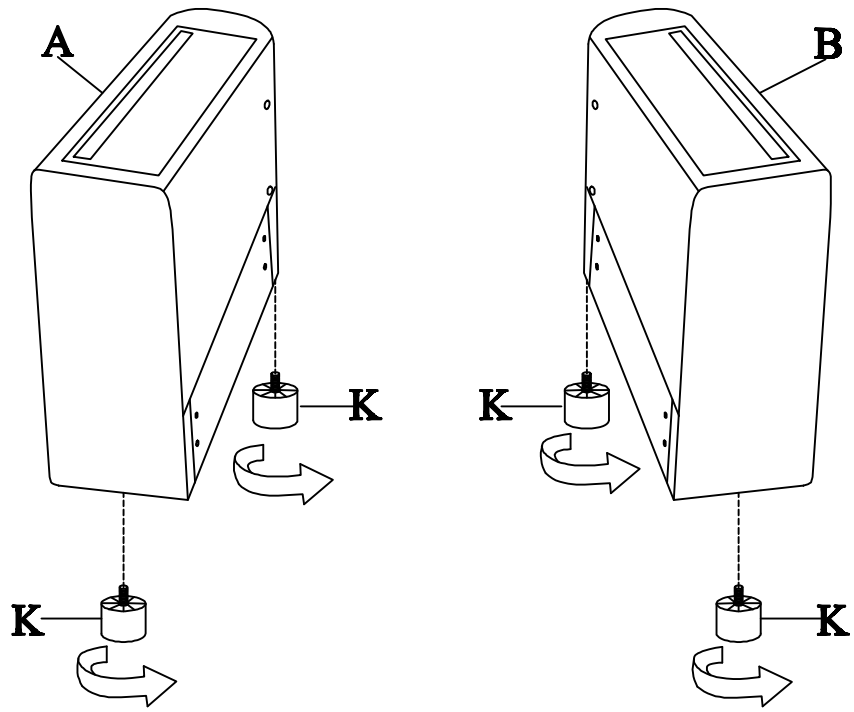

Step 2:

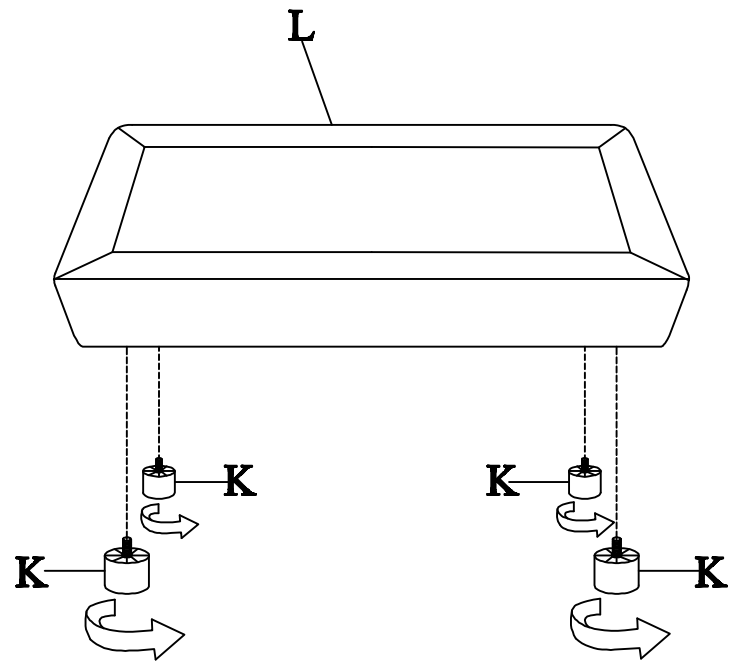

Step 3:



Step 4:

- O**  **8pcs**
- U**  **8pcs**
- Y**  **1pc**

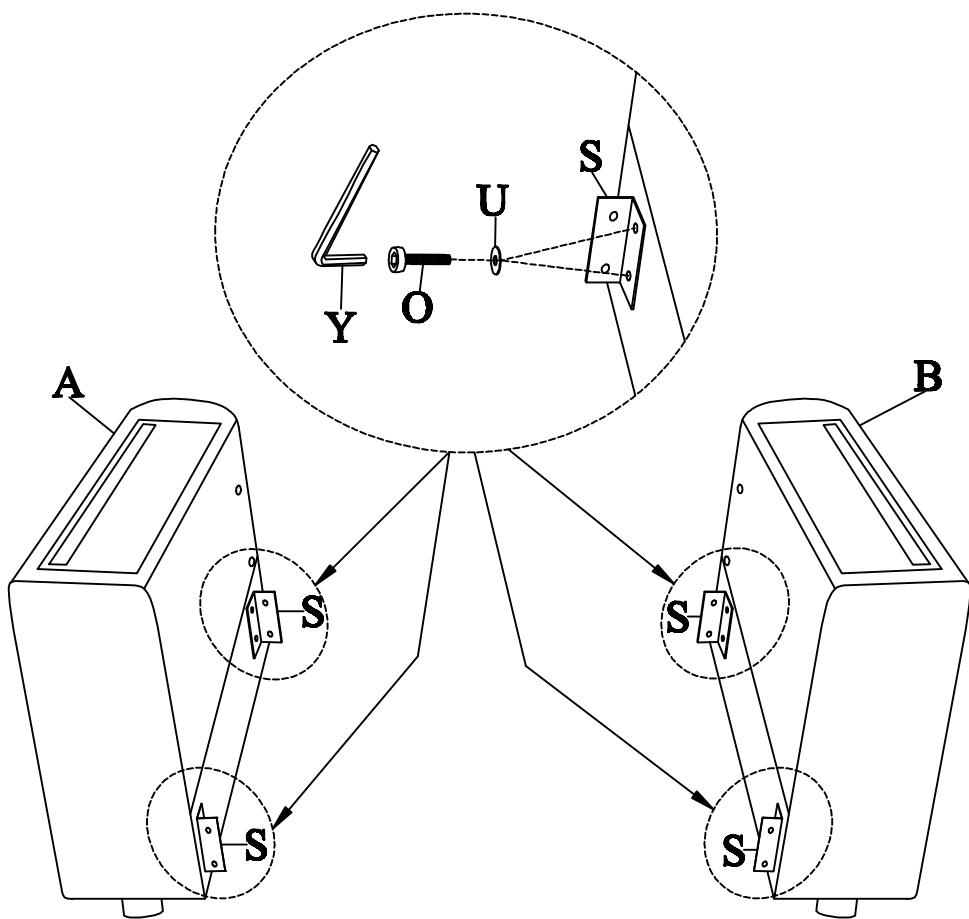

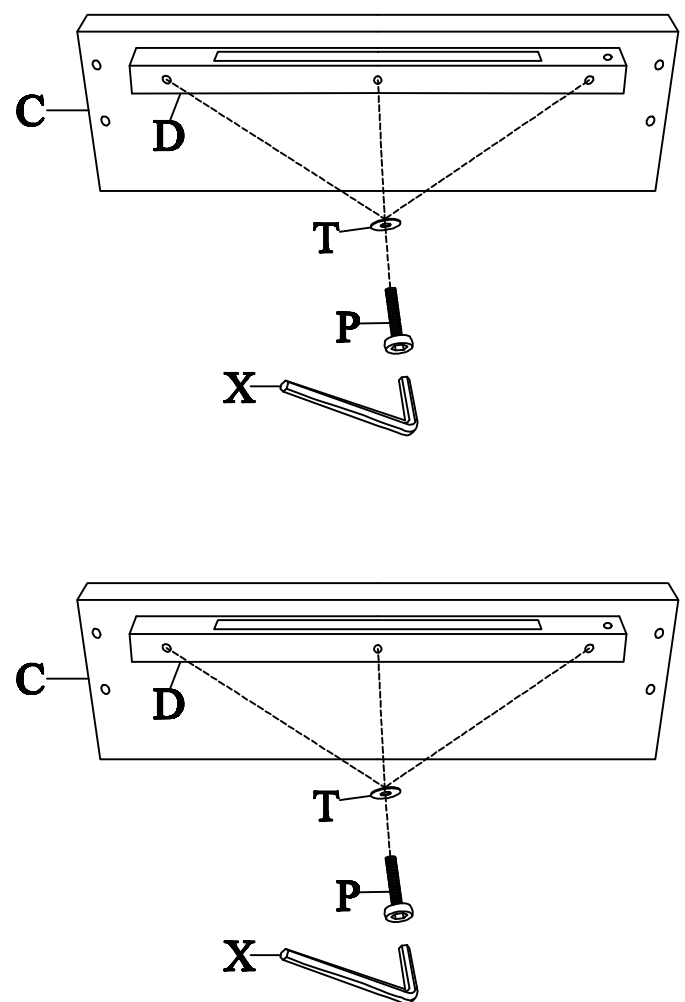

Step 5:

- P**  **6pcs**
- T**  **6pcs**
- X**  **1pc**





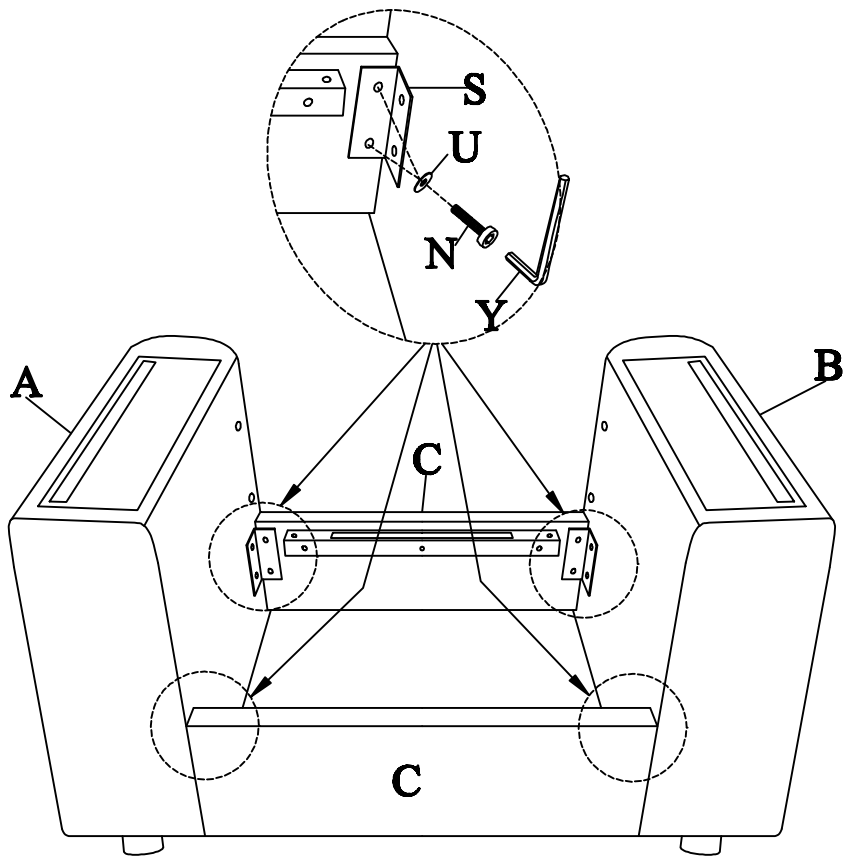

Step 6:

- N  8pcs
- U  8pcs
- Y  1pc

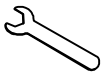

Step 7:

- R  4pcs
- T  8pcs
- X  1pc
- V  4pcs
- W  1pc

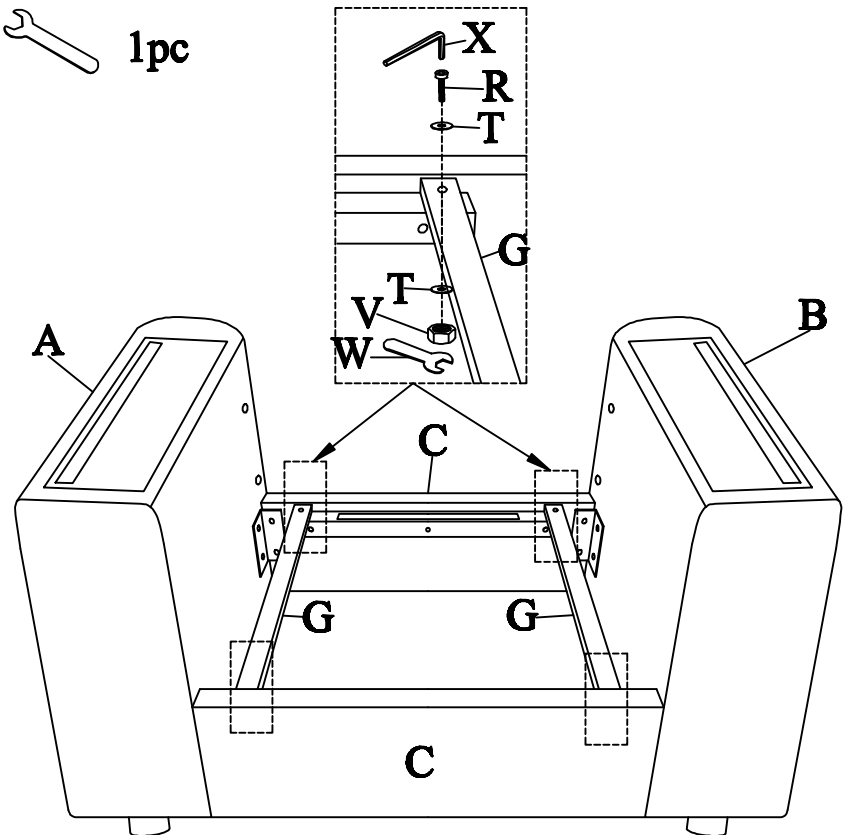

Step 8:

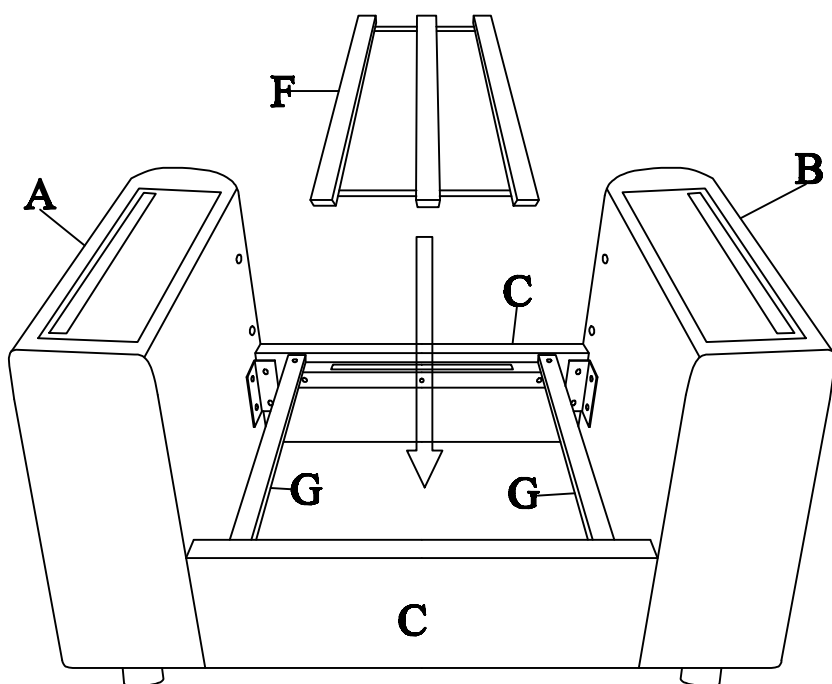

Step 9:

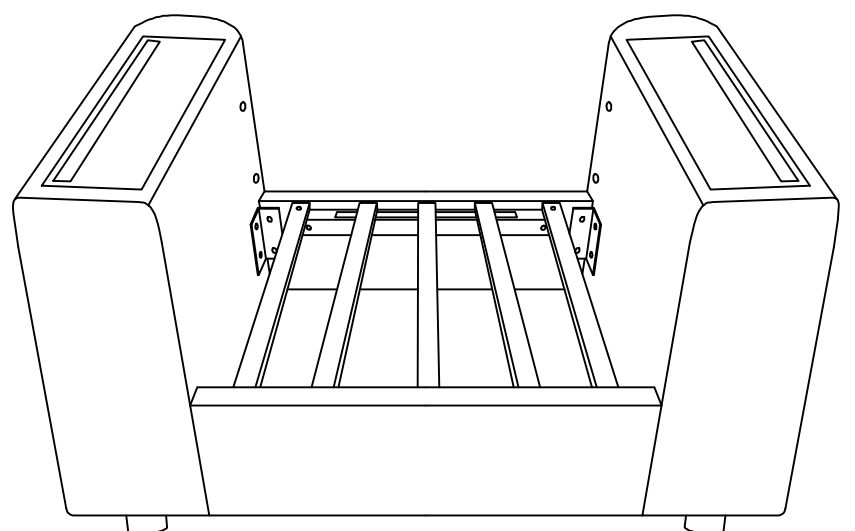

Step 10:

Q  **4pcs**

U  **4pcs**

Y  **1pc**

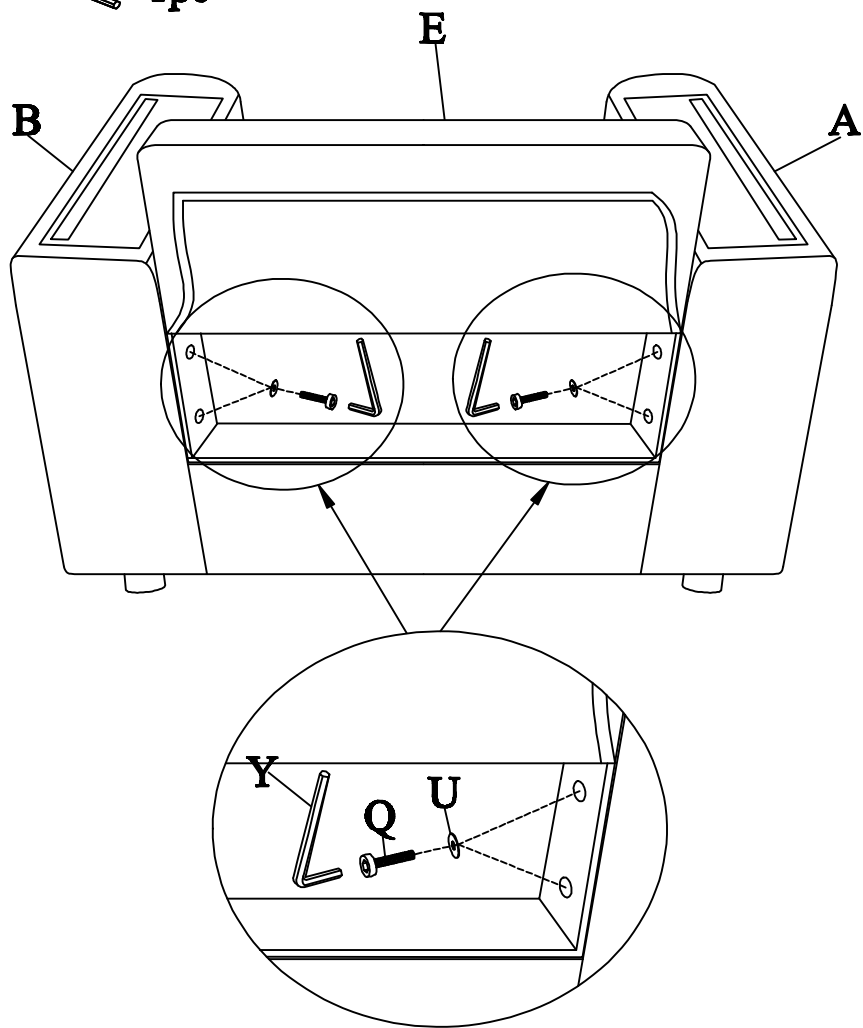

Step 11:

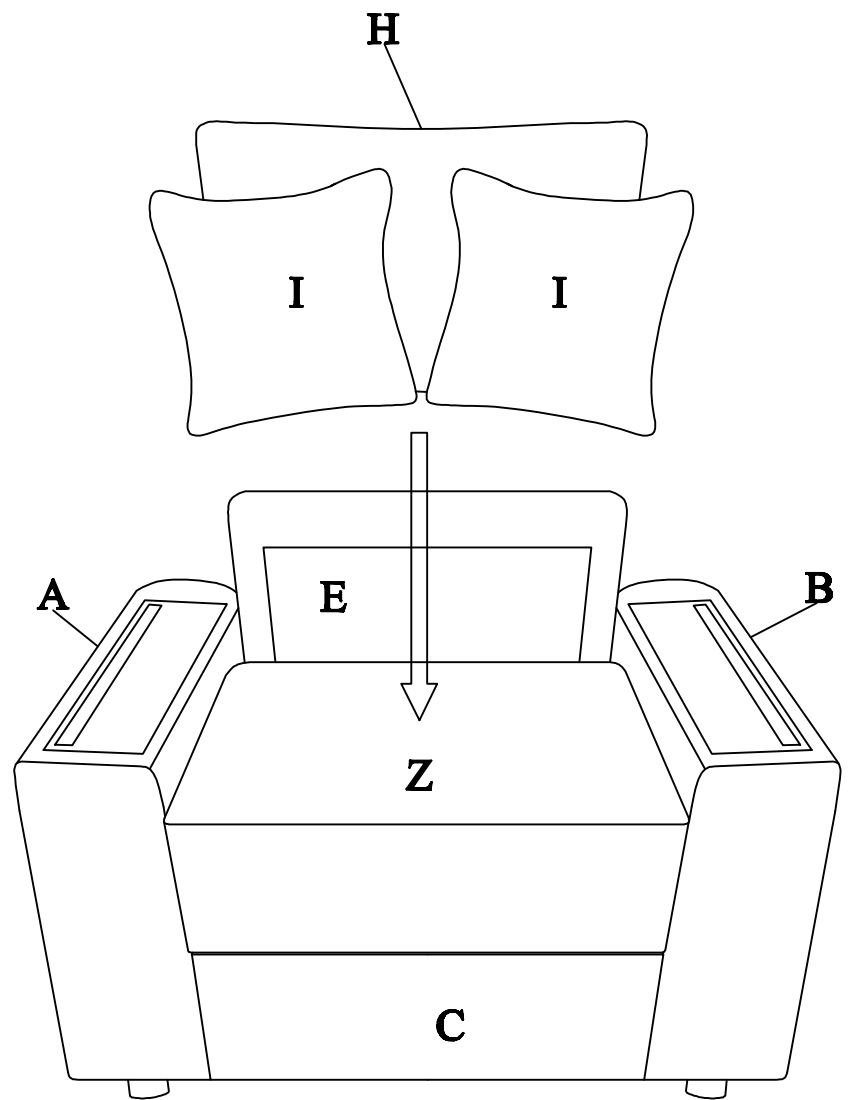

Step 12:

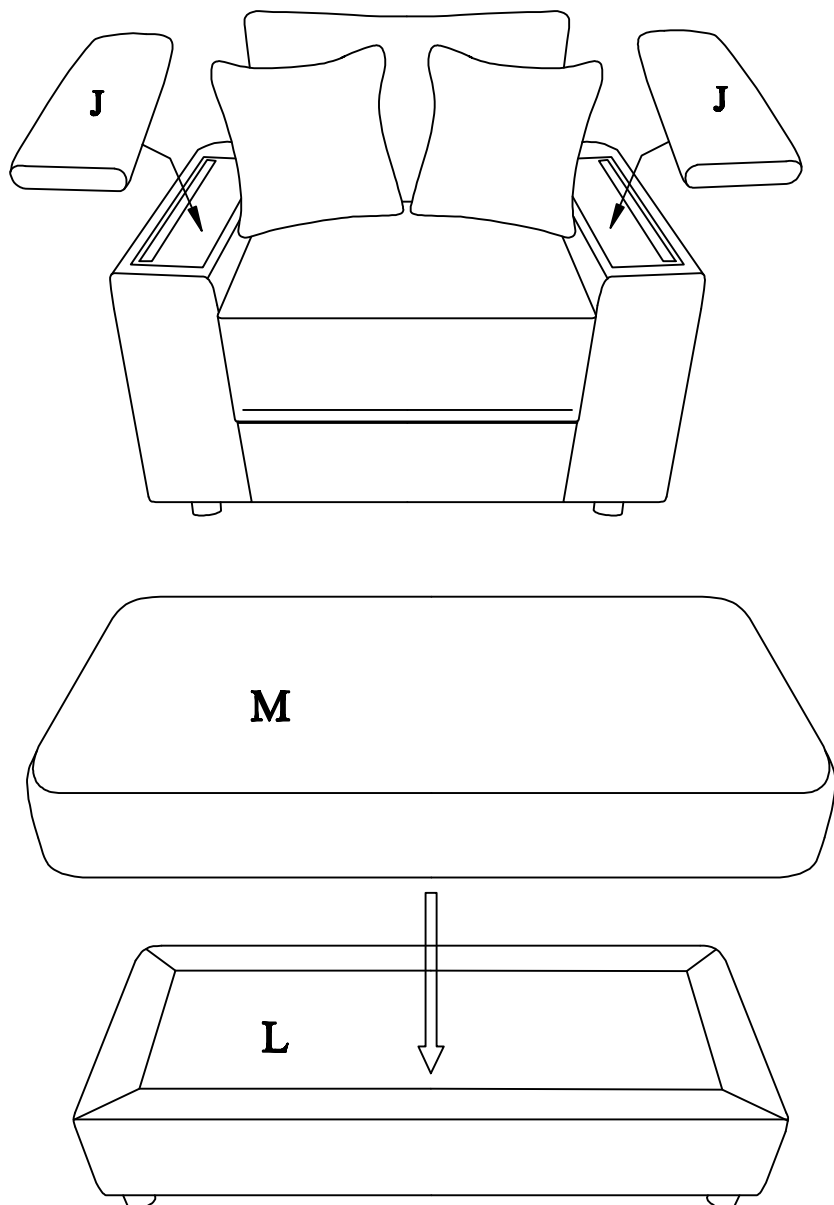

Step 13:

