

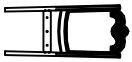





ASSEMBLY INSTRUCTION

SIDE CHAIR

PARTS LIST

1		CHAIR BACK	1 PC
2		SEAT	1 PC
3		FRONT LEG	2 PC

HARDWARE LIST

A		Ø5/16"-18x1-1/2"L (CHAIR BACK CENTER)	1 PC
B		Ø5/16"-18x2-1/2"L (FRONT LEG)	4 PCS
C		Ø5/16"-18x3"L (CHAIR BACK LEG CORNER)	4 PCS
D		Ø5/16"	1 PC

Step 1

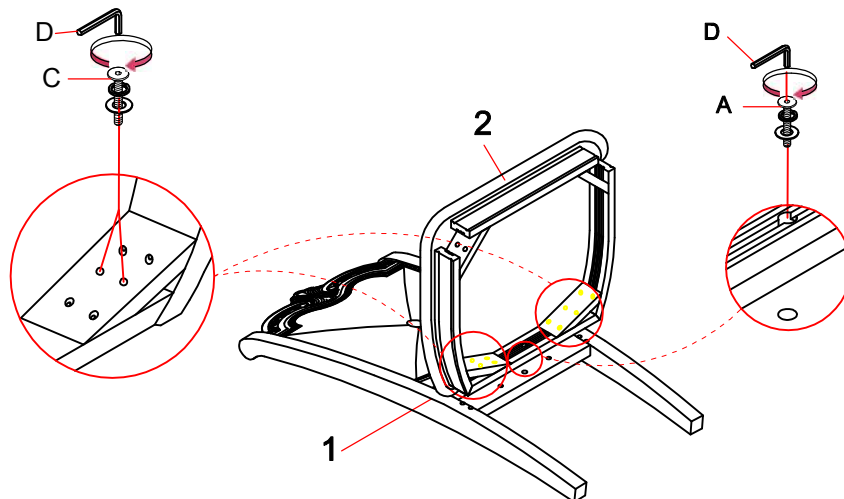

Step 2

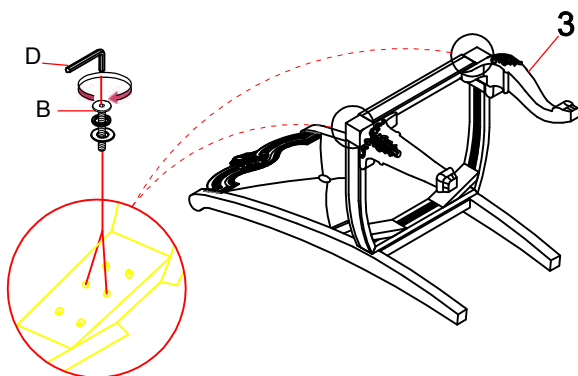

Step 3

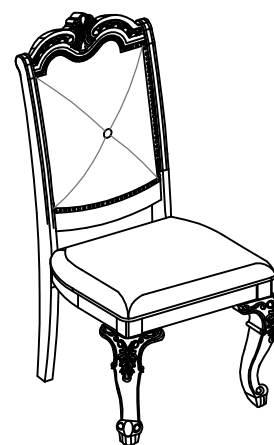

THE HARDWARE IS LOCATED
IN THE PACKING ITEMS.

NOTE:
DURING ASSEMBLY DO NOT FULLY
TIGHTEN ANY HARDWARE UNTIL THE
COMPLETE UNIT HAS BEEN ASSEMBLED.