

SICOTAS

Cas Bookcase

BK131A1CGYY1969 / BK131A1CLTY1970 / BK131A1CBKY1971

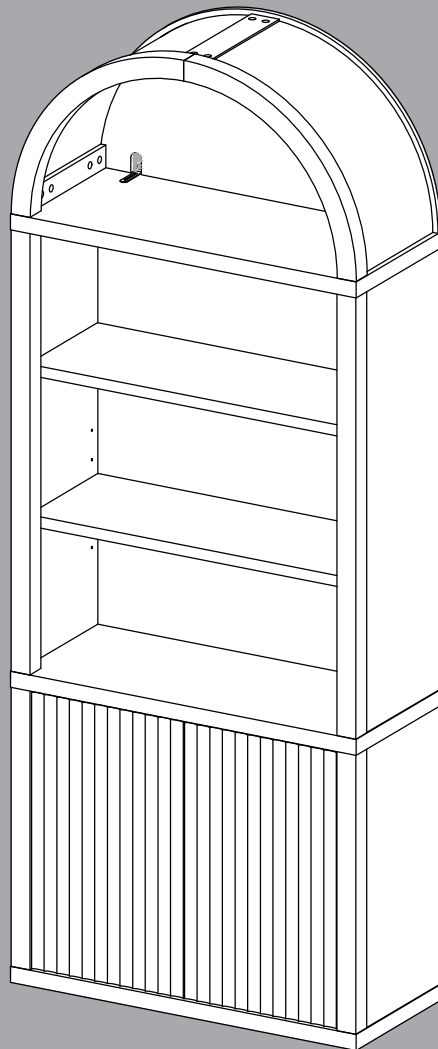

Cas Collection

Assembly Instructions

Before beginning the assembly process, please read and save these instructions for reference. Following these guidelines will ensure a smooth and successful assembly of your product.

1. Part Identification:

Carefully separate and identify all the parts included in your package. Confirm that you have all the components listed in the instruction manual. This step will help you avoid any missing or misplaced parts during assembly.

2. Work Surface:

To prevent any scratches or damage to the product, assemble it on a soft mat or a similar protective surface. This will provide a cushioned area for the components and protect the surfaces from unwanted marks.

3. Step-by-Step Assembly:

Follow the assembly instructions provided, proceeding one step at a time. Take care to understand each step properly before proceeding to the next one. This sequential approach ensures that the assembly is done correctly and minimizes the chance of errors.

4. Proper Screw Seating:

When attaching screws and nuts, it is essential not to fully tighten them until all screws are correctly seated. By partially tightening each screw and nut initially, you can ensure that they are aligned properly and fit securely before final tightening.

5. Avoid Over-Tightening:

While each screw and nut should be tightened correctly, it is crucial not to over-tighten them. Over-tightening can cause damage to the product or compromise its structural integrity. Use the appropriate amount of force to secure the components without excessive tightening.

SICOTAS customer help center:

If you encounter any questions or problems during the assembly process, please do not hesitate to contact us.

We strive to provide excellent customer support and will respond to your inquiries within 24 hours. Our team will offer you a suitable solution to address any concerns you may have.



Email:
service@sicotas.com



Website:
www.sicotas.com



Phone:
(833) 742-6827



Official Website:



WhatsApp:



YouTube:



Instagram:



Facebook:



TikTok:

Parts List

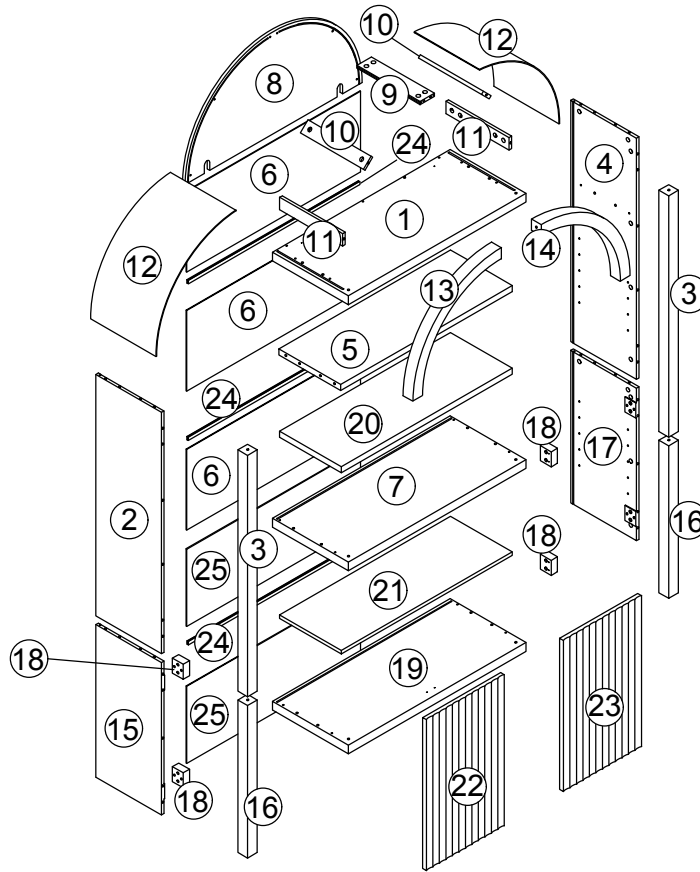

Hardware List

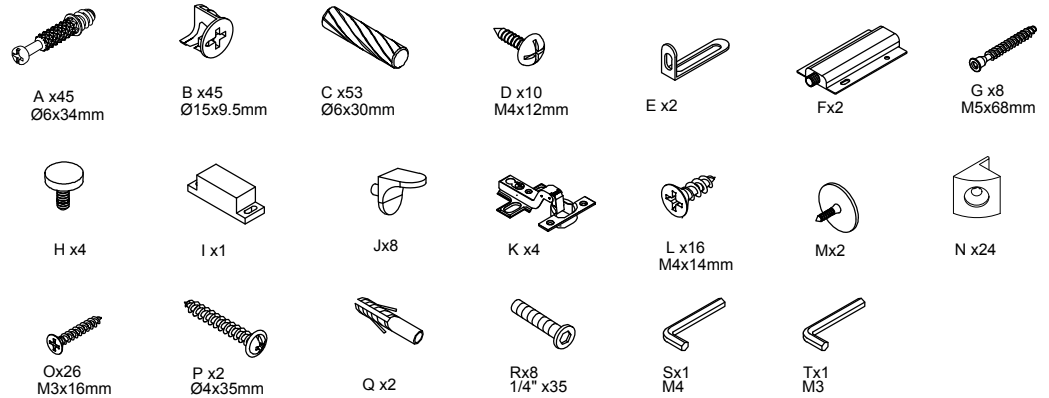

Code	Description	Quantity	Code	Description	Quantity
A	M6*34mm Cam bolt	45+2	L	M4x14mm Screw	16+2
B	Ø15x9.5mm Cam lock	45+2	M	Rebound gasket	2
C	Φ6x30mm Wood dowel	53+2	N	Back clip	24+2
D	M4x12mm Screw	10+2	O	M3x16mm Screw	26+2
E	Anti falling iron sheet	2	P	Ø4x35 self-tapping screw	2
F	Rebound device	2	Q	Plastic expansion screw	2
G	M5x68 Broken tail screw	8+2	R	1/4"x35 hexagonal screw	8+2
H	M8x(Ø30)x20 Adjustable foot	4+1	S	M4 Wrench	1
I	Magnet	1	T	M3 Wrench	1
J	Metal Pin	8+2			
K	Hinge	4			

Step 1

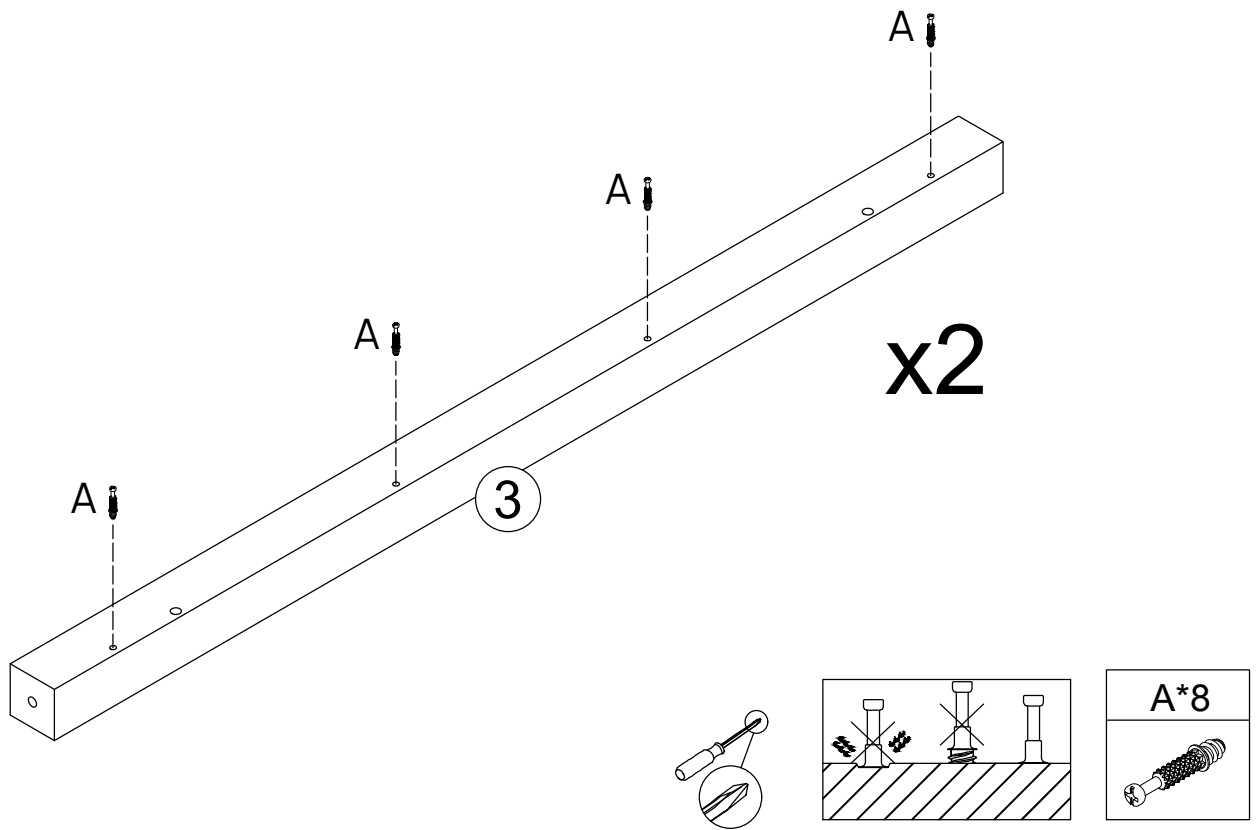

Step 2

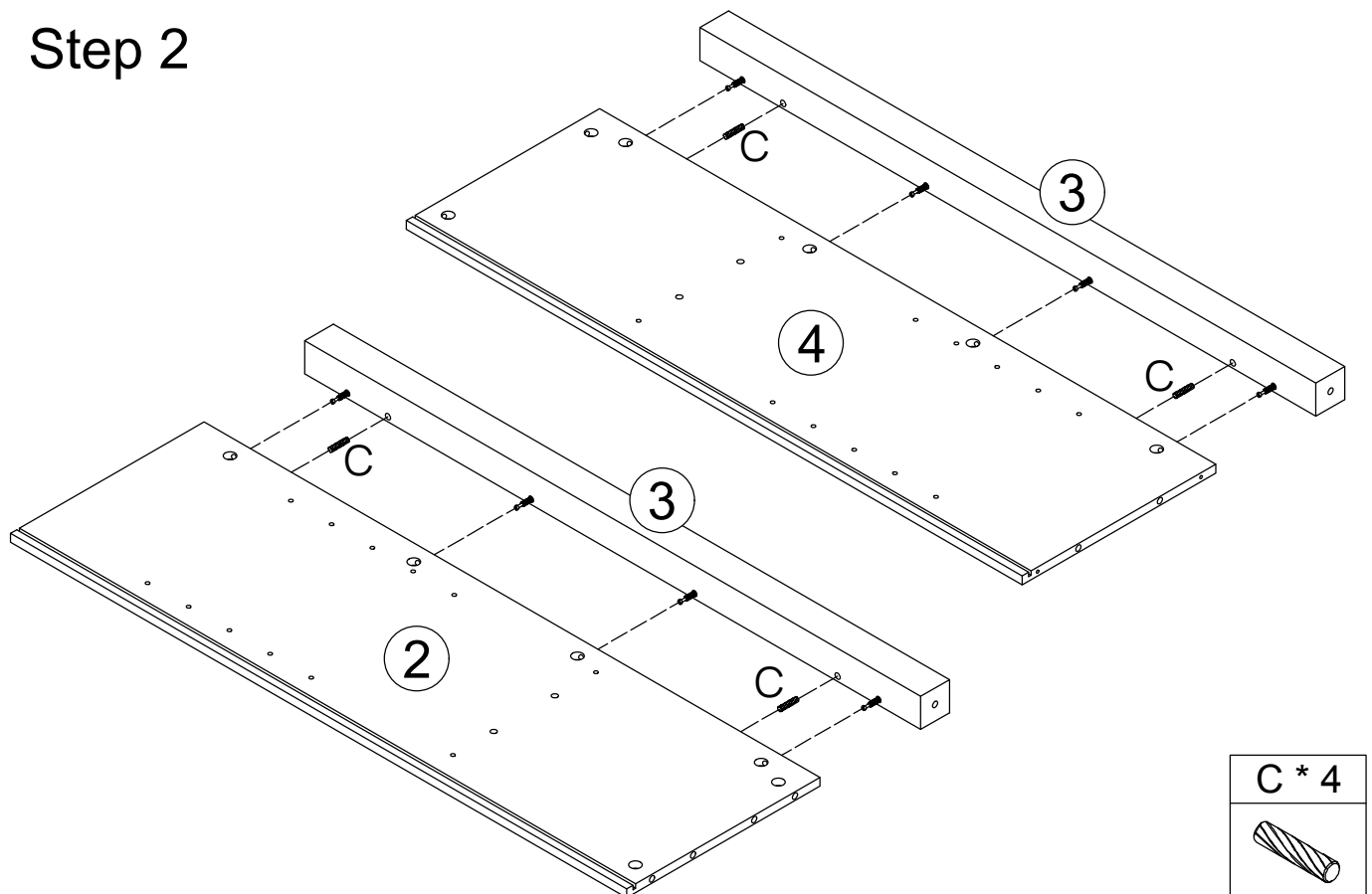

Step 3

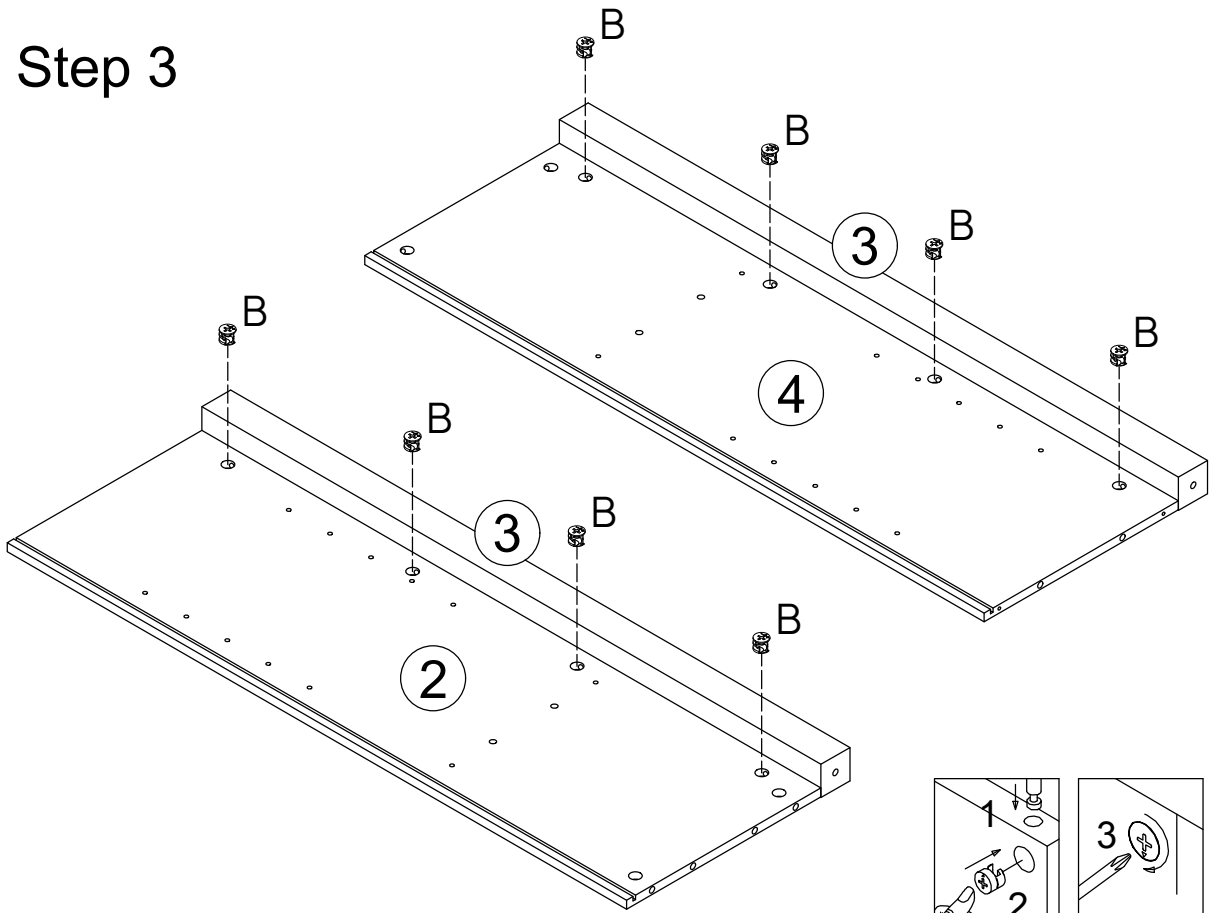

Step 4

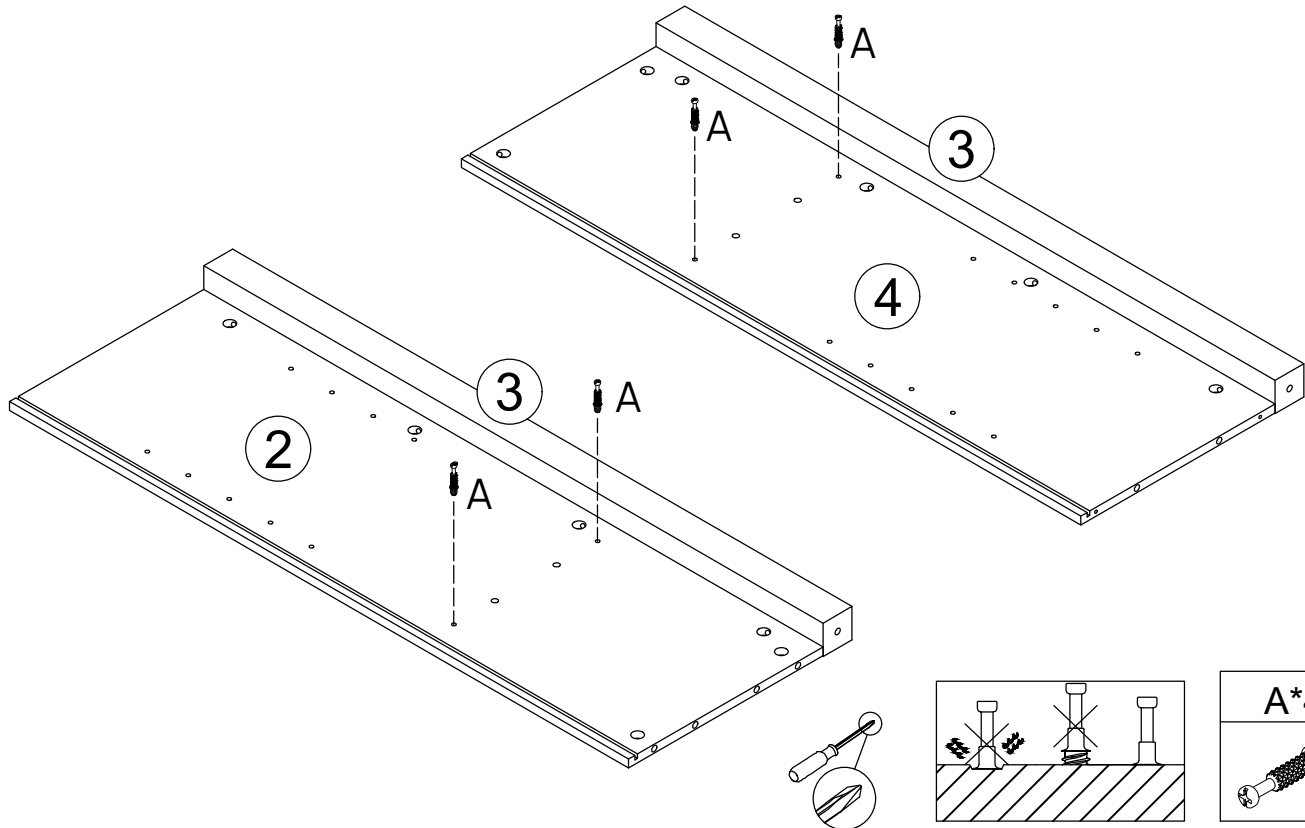

Step 5

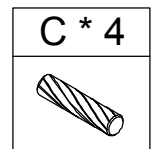
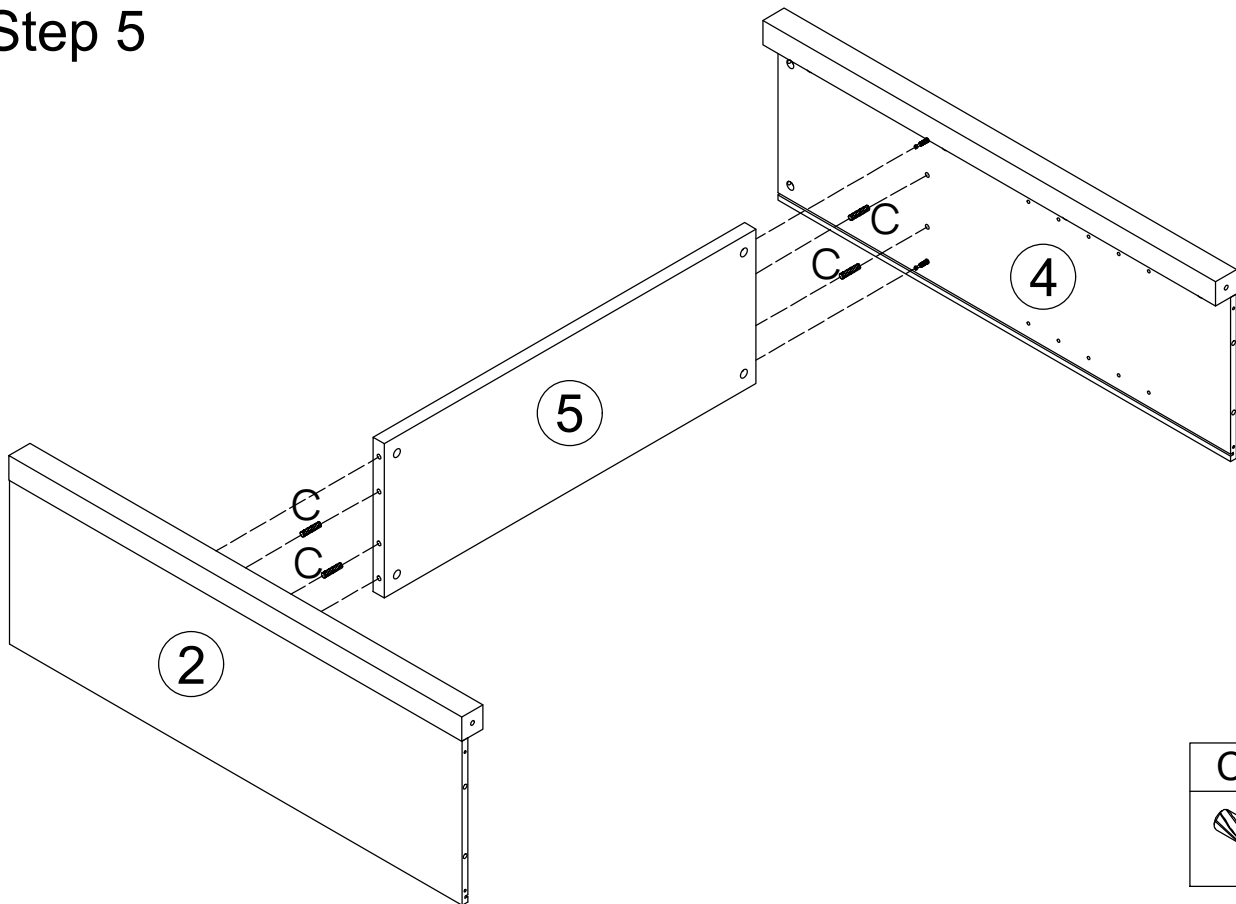

Step 6

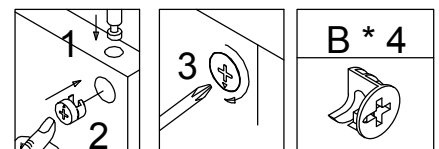
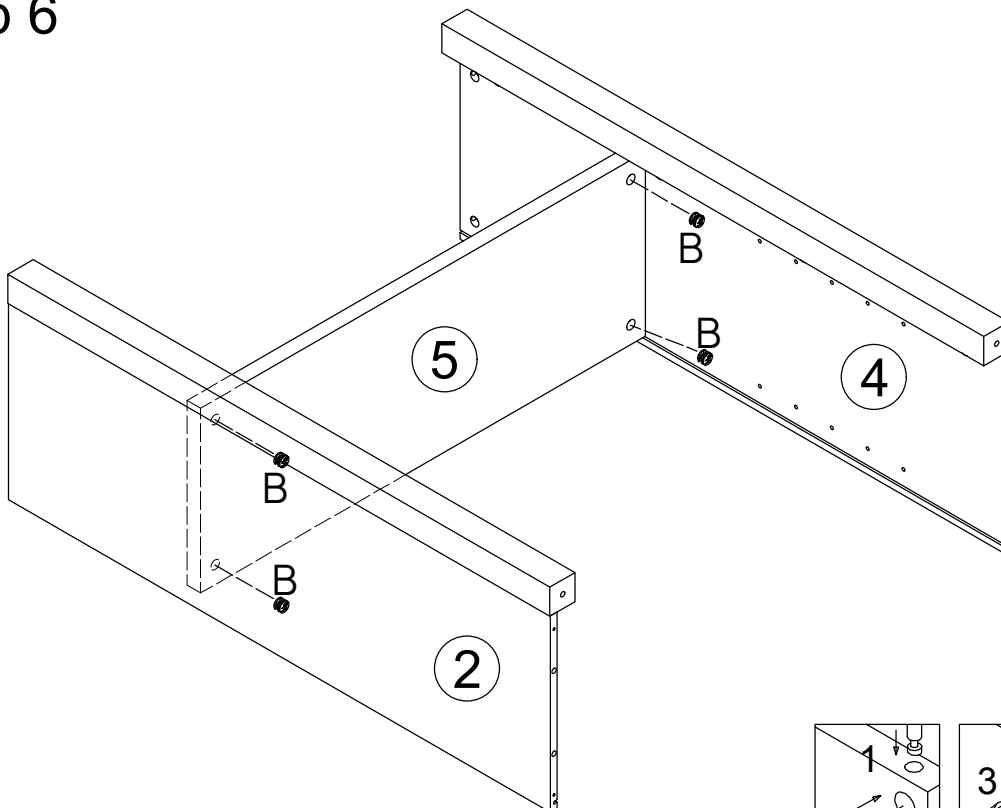

Step 7

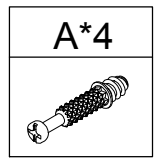
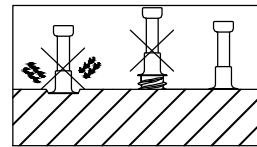
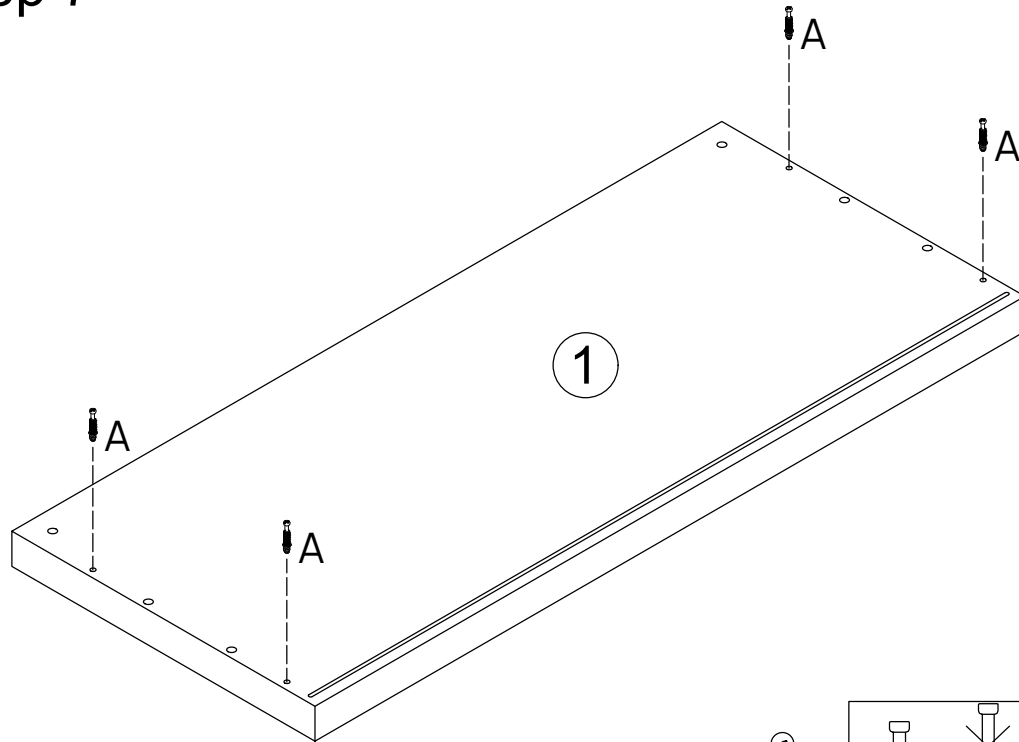

Step 8

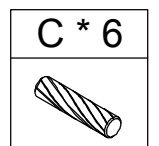
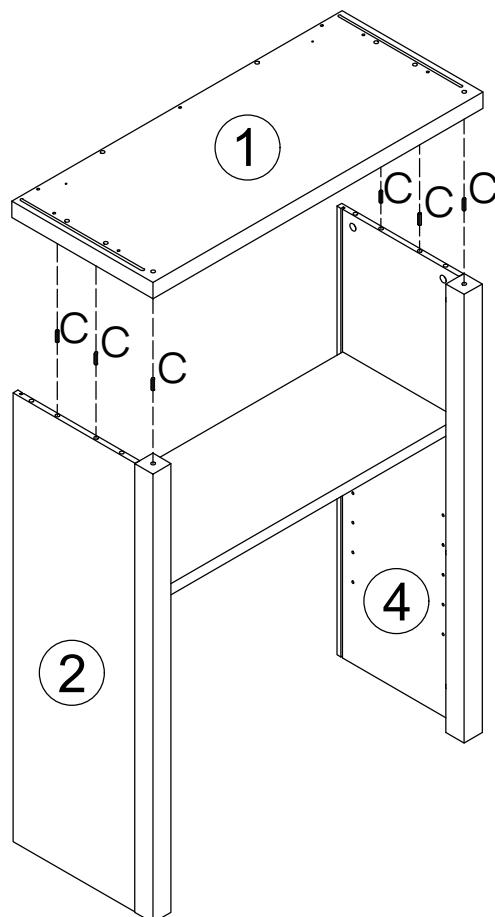

Step 9

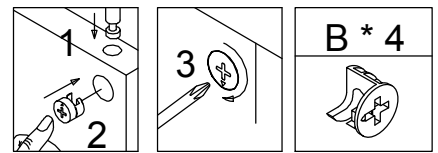
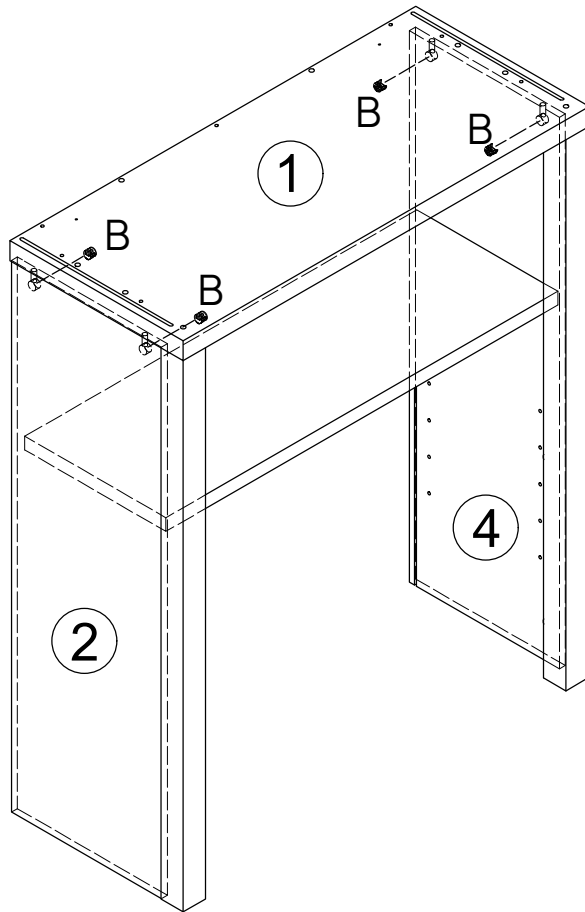

Step 10

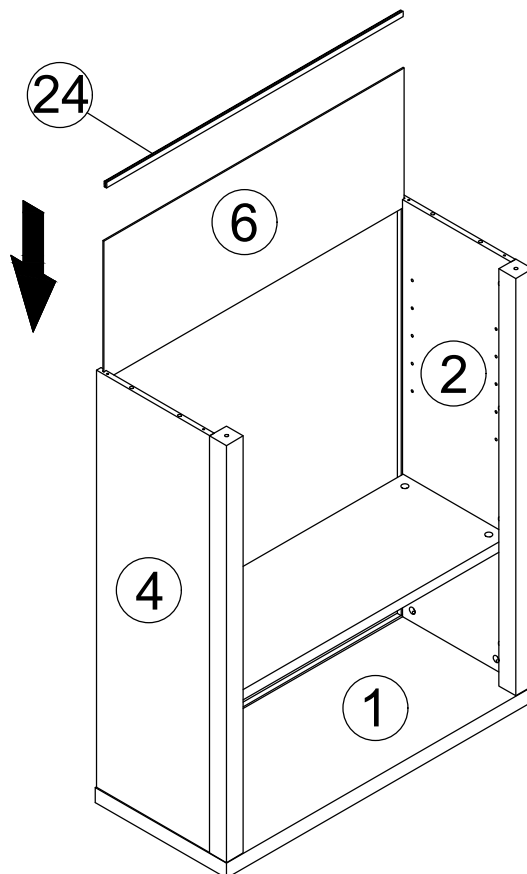

Step 11

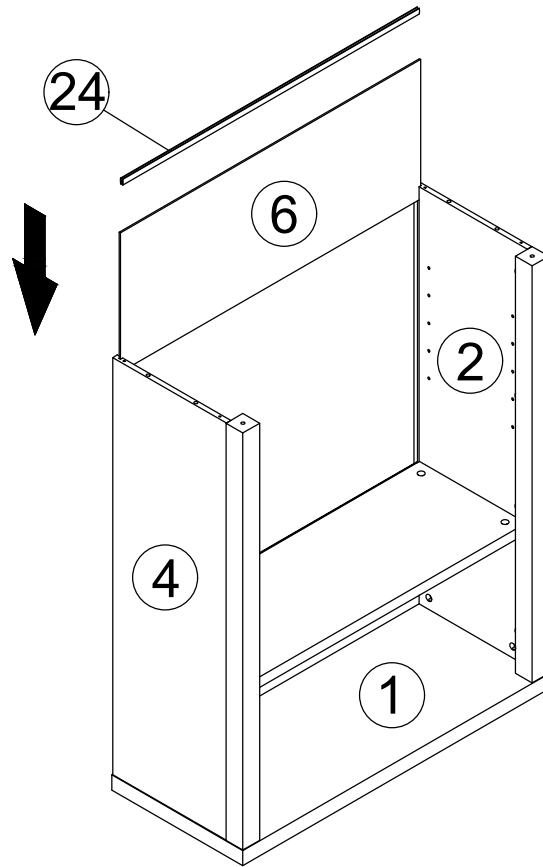

Step 12

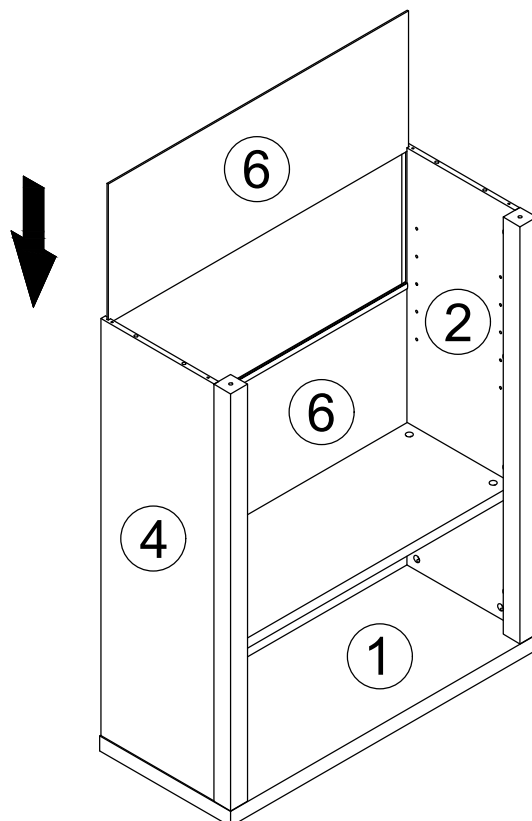

Step 13

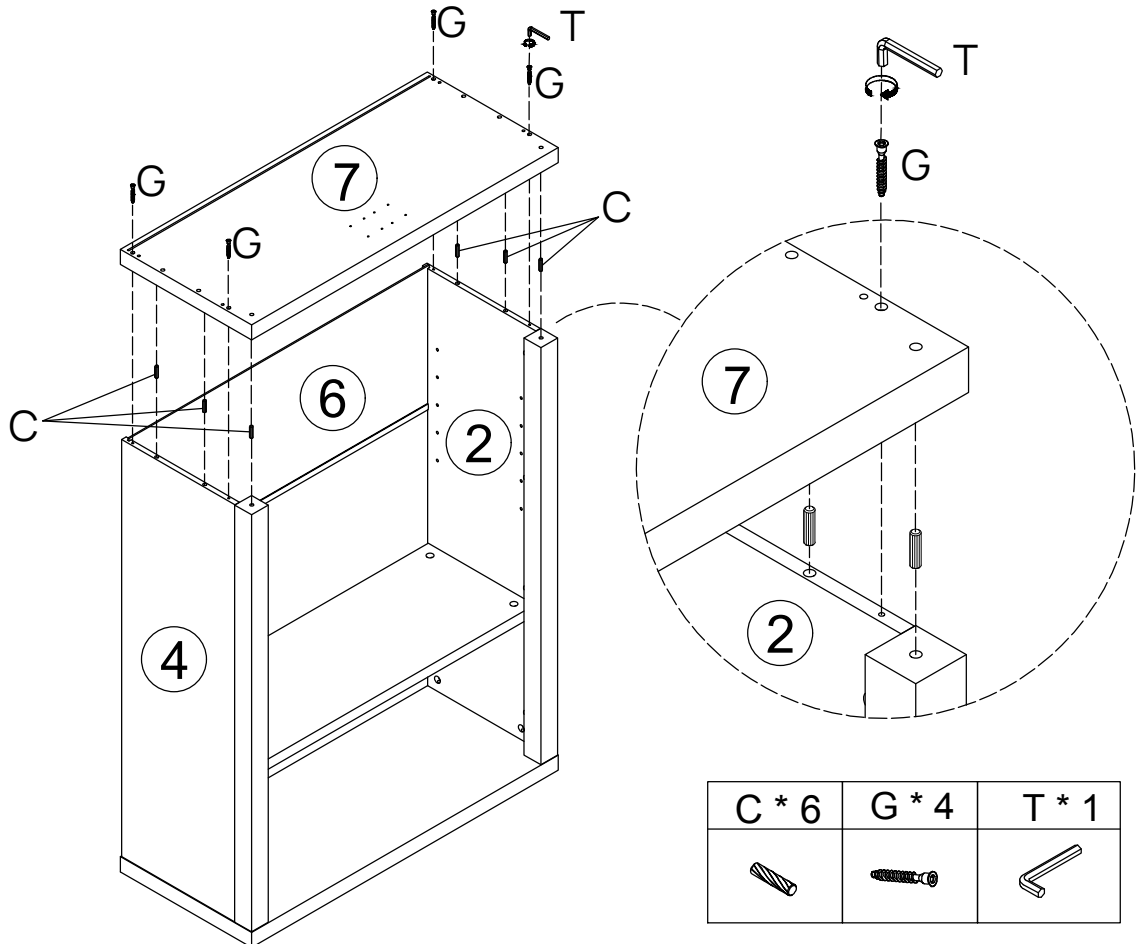

Step 14

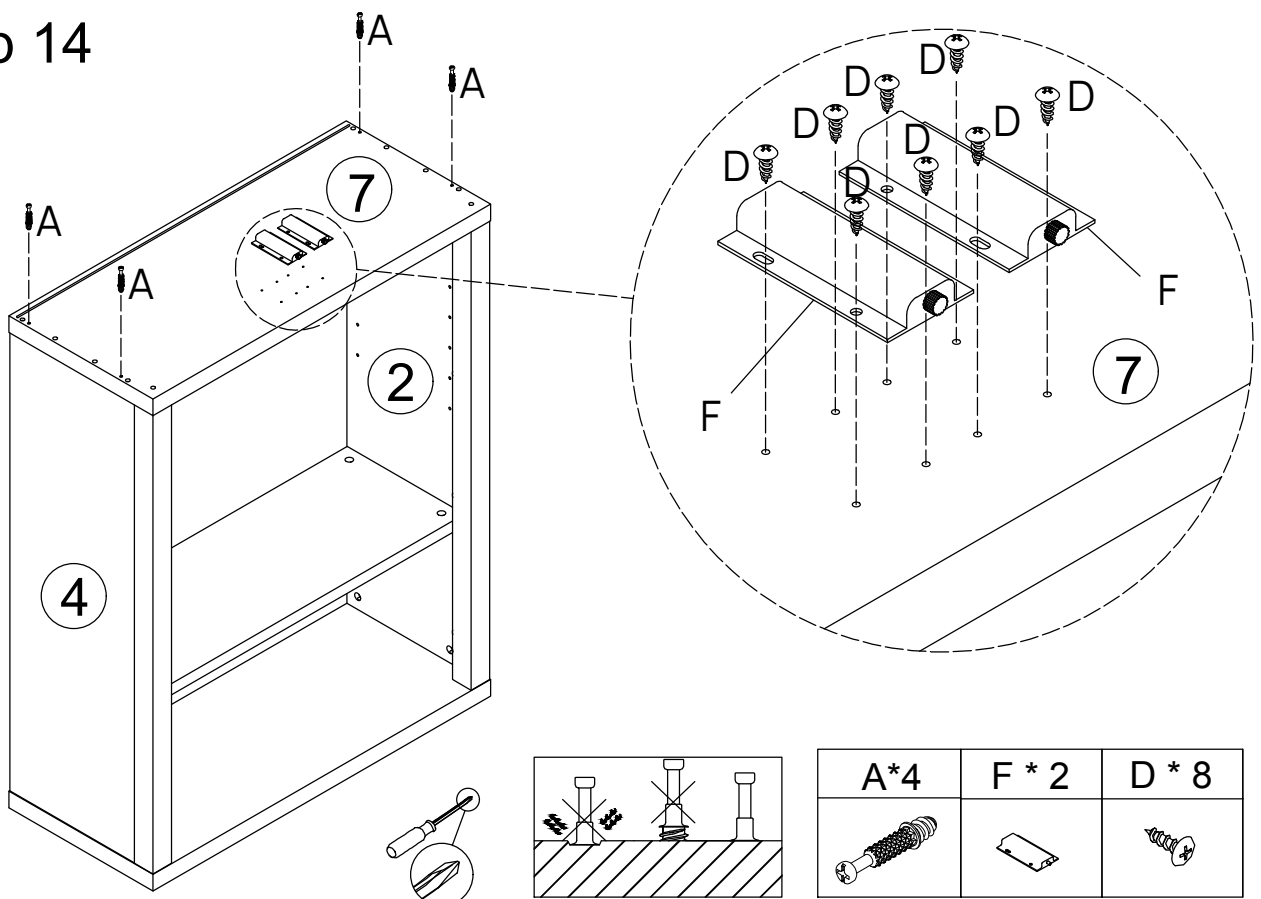

Step 15

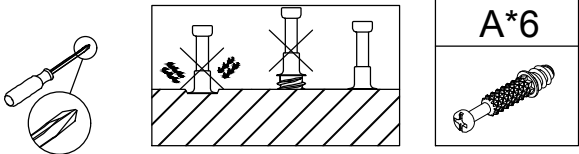
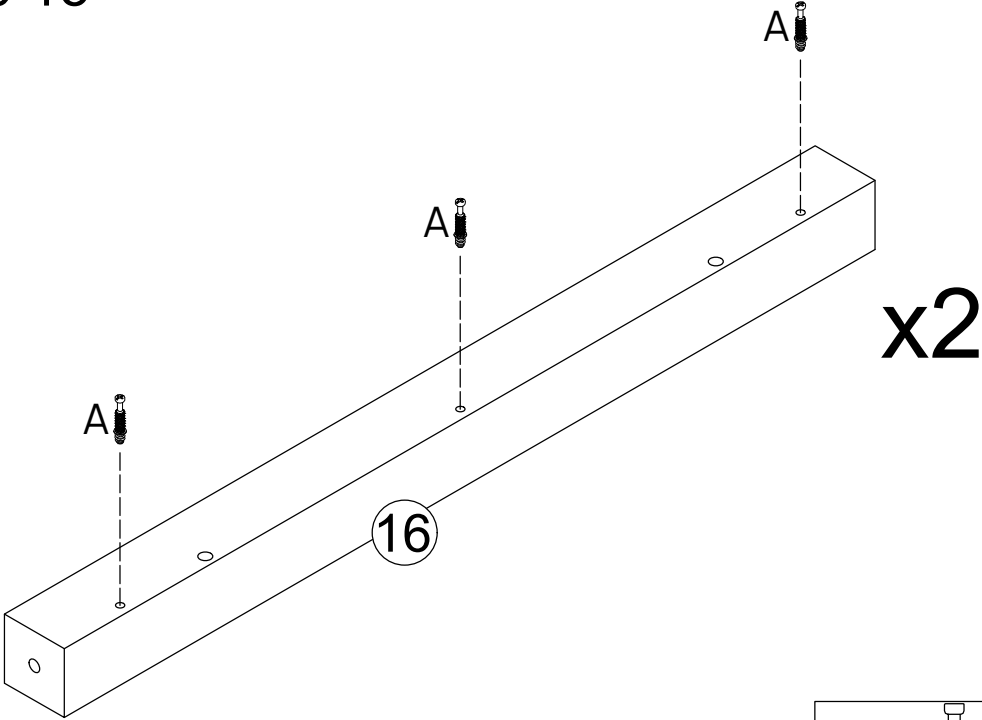

Step 16

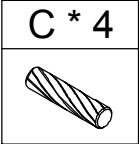
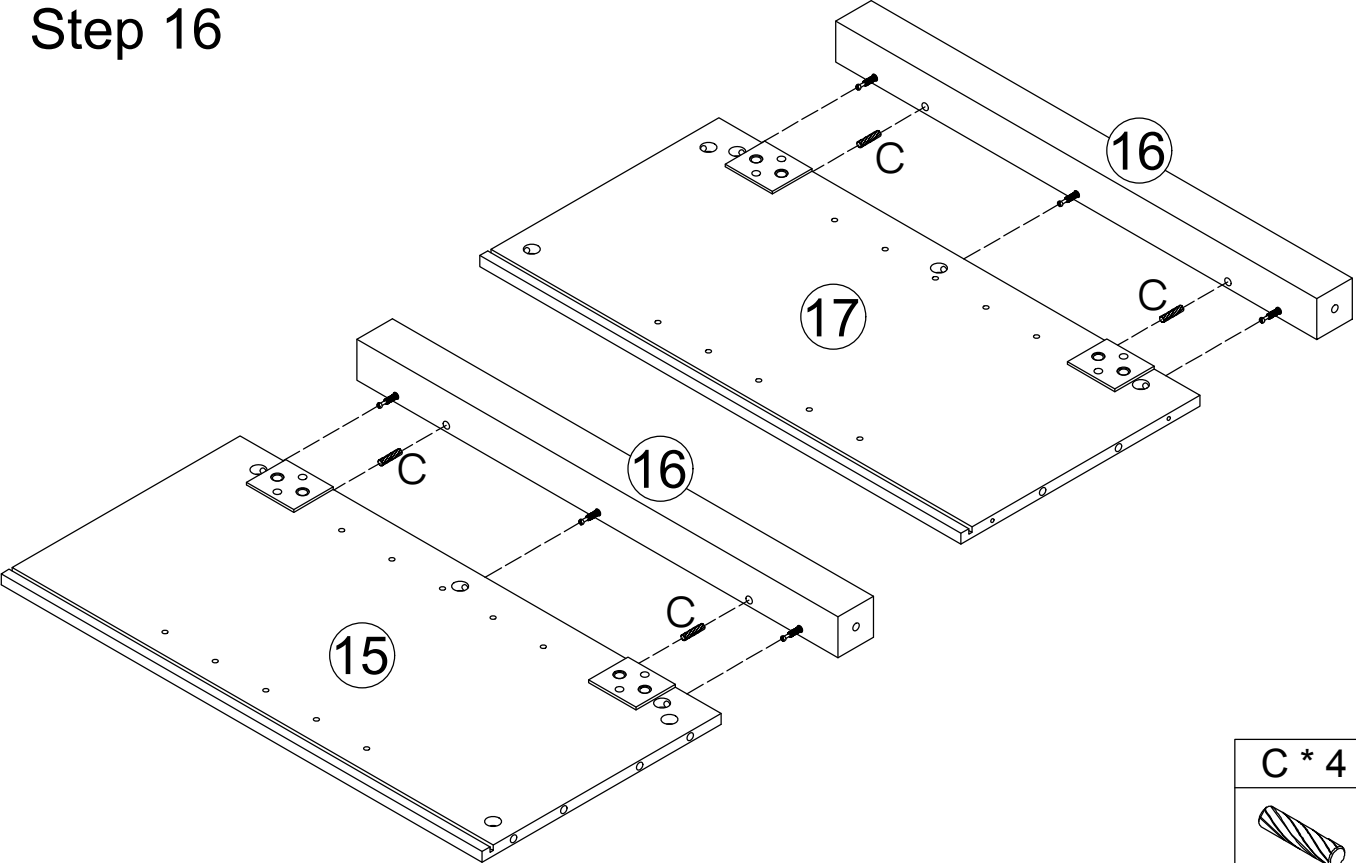

Step 17

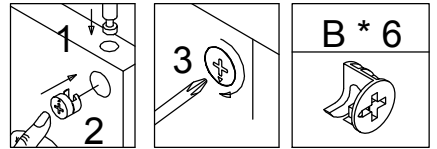
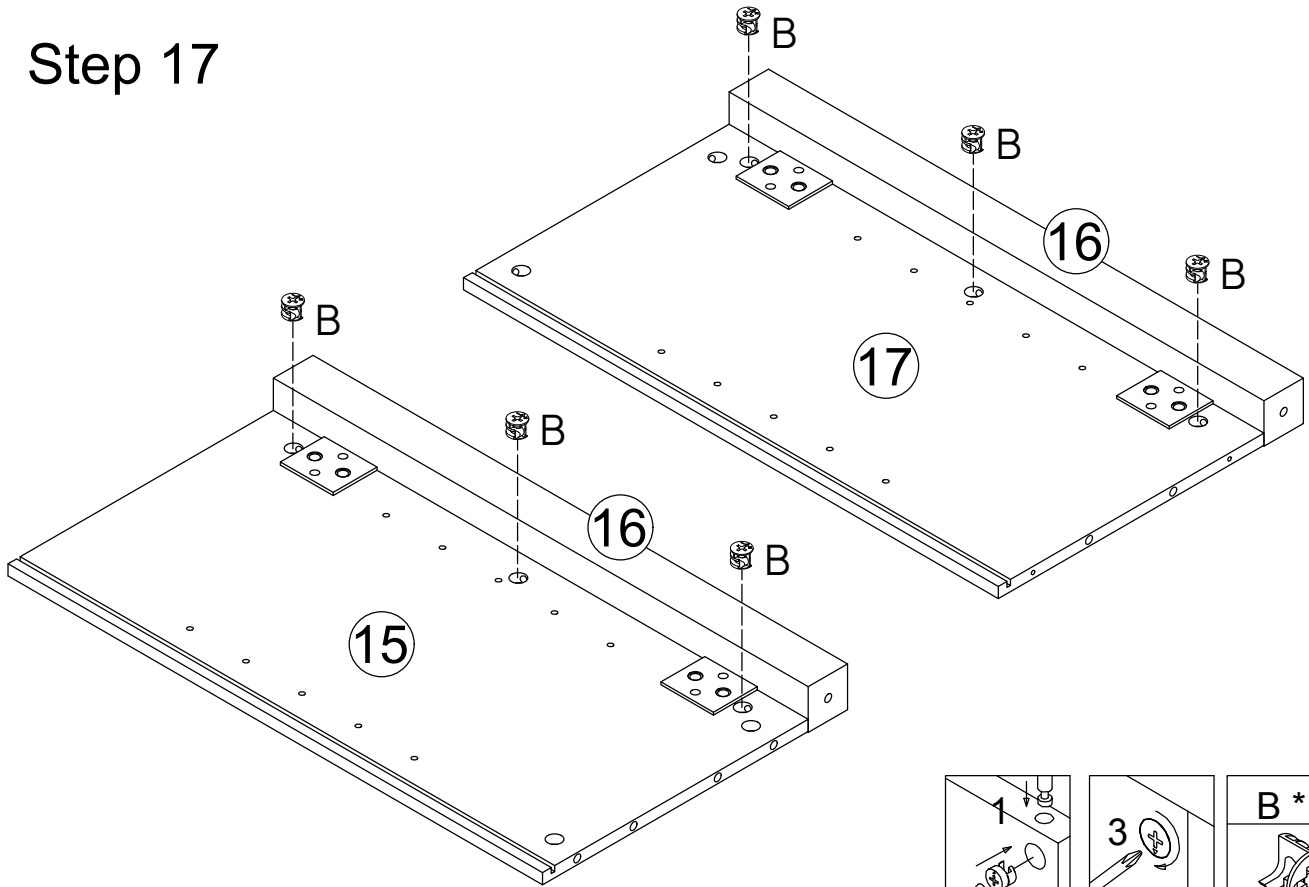

Step 18

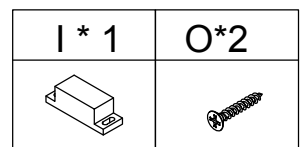
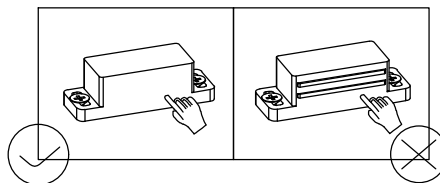
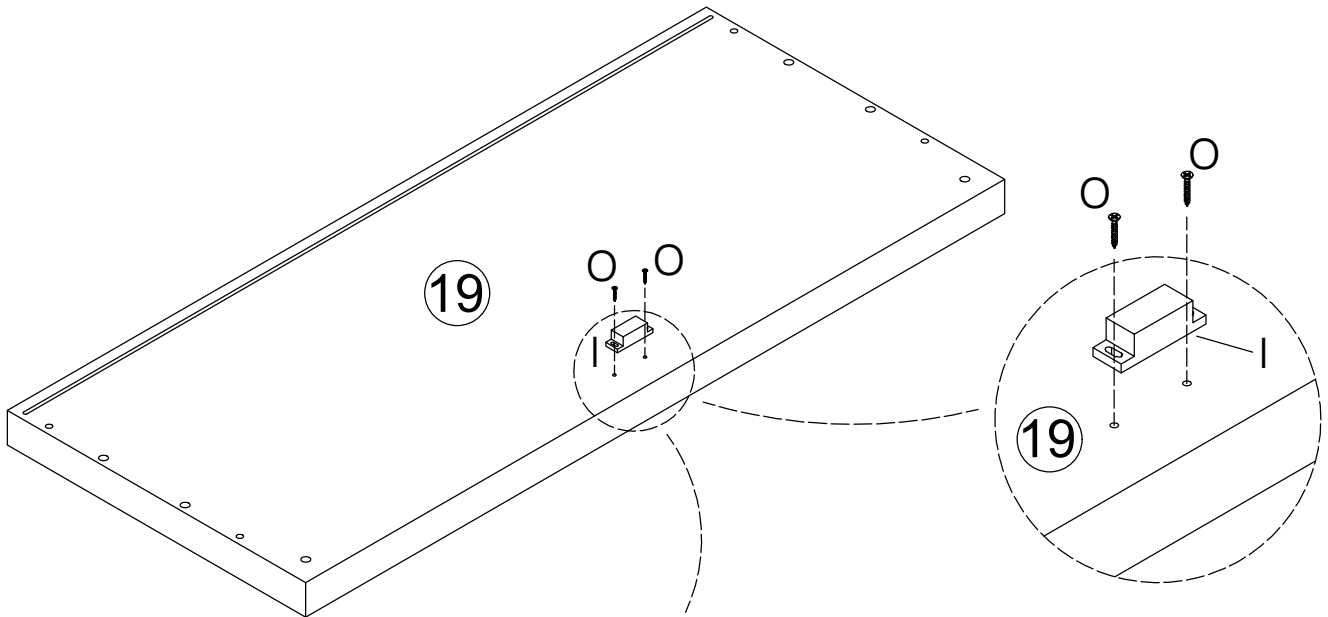

Step 19

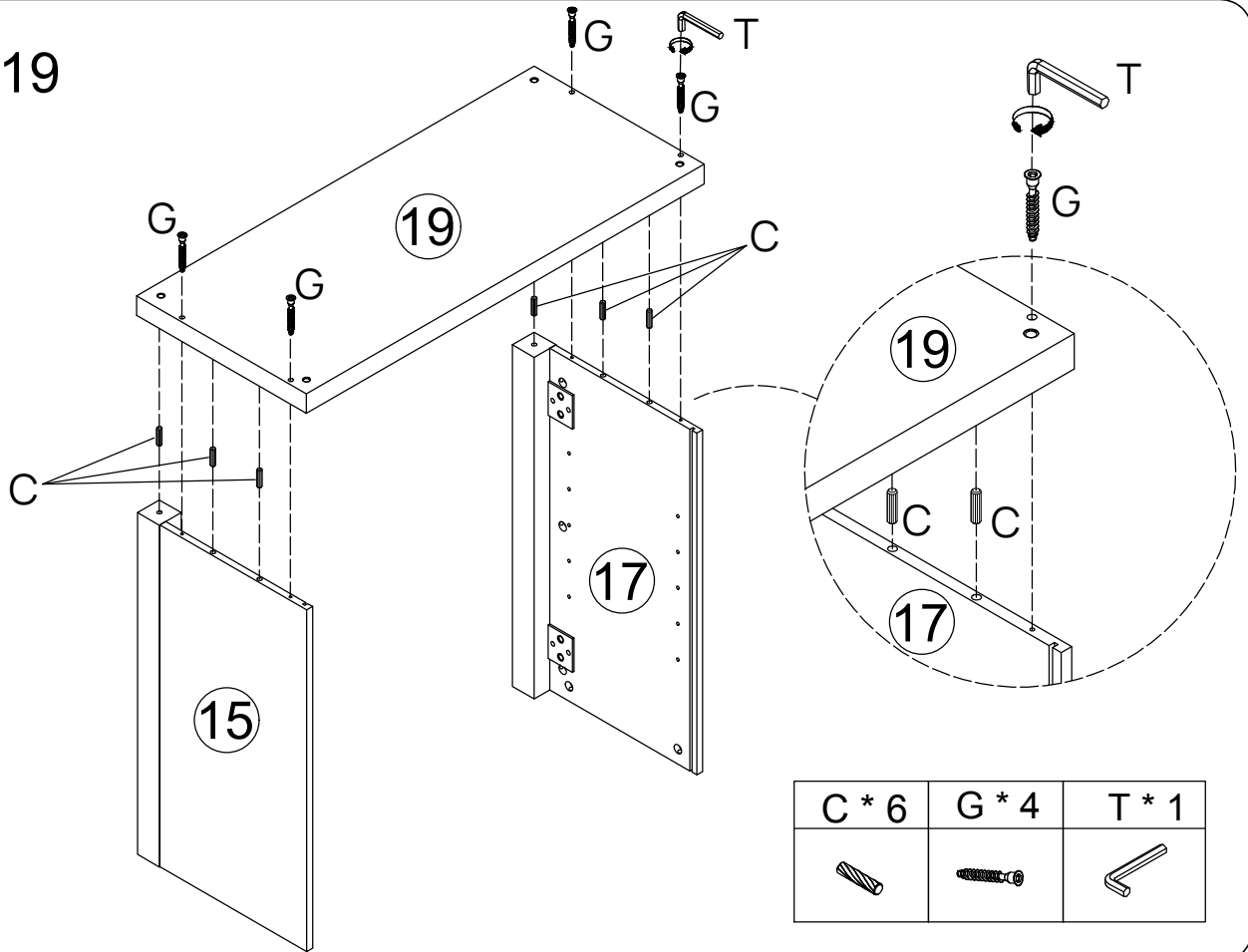

Step 20

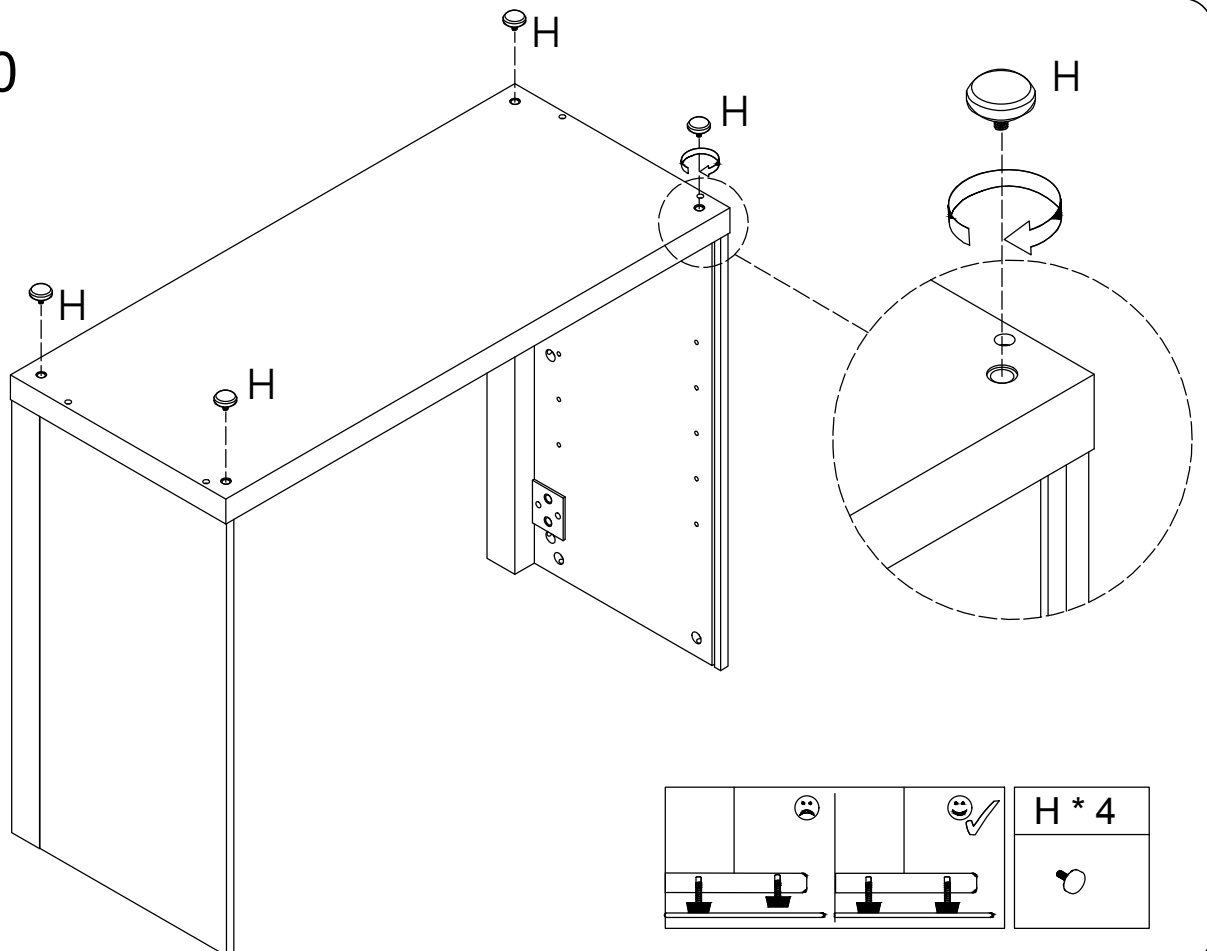

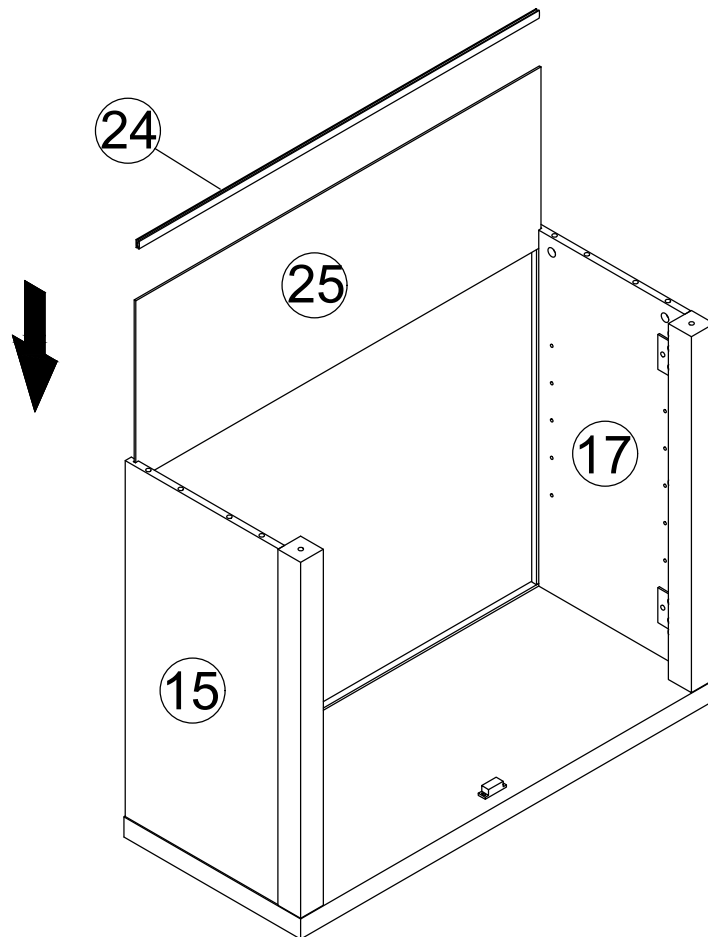
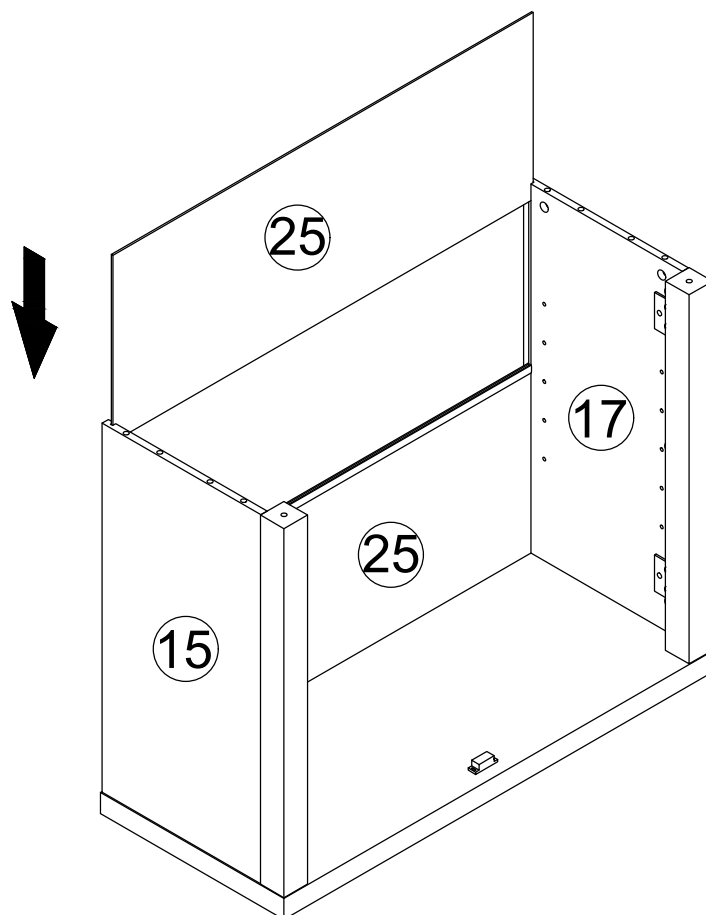
Step 21**Step 22**

Step 23

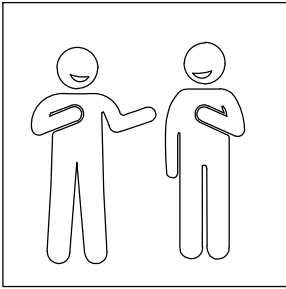

CAUTION : Heavy! You may need assistance with this step.

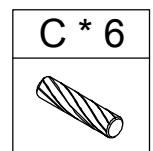
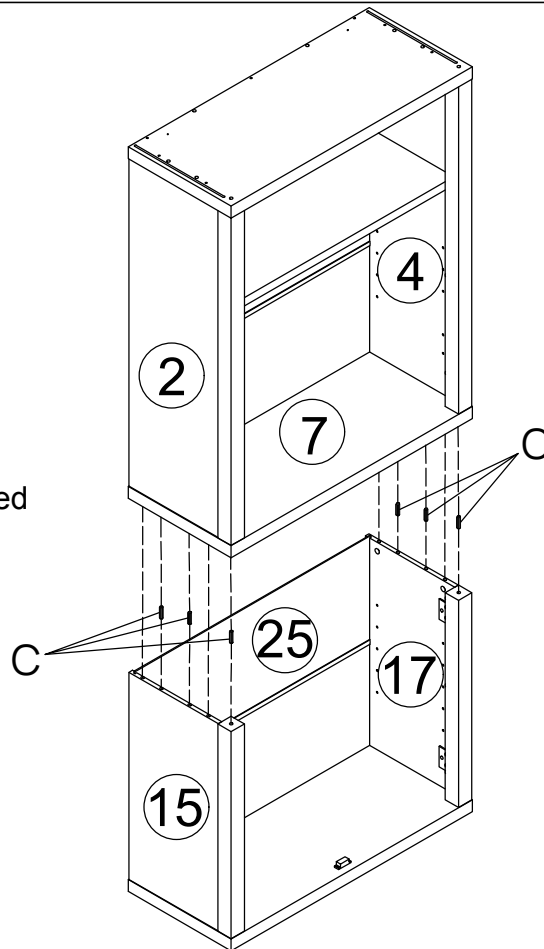

Step 24

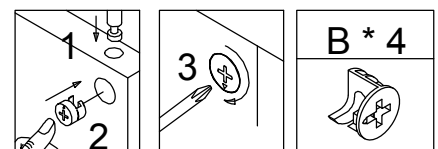
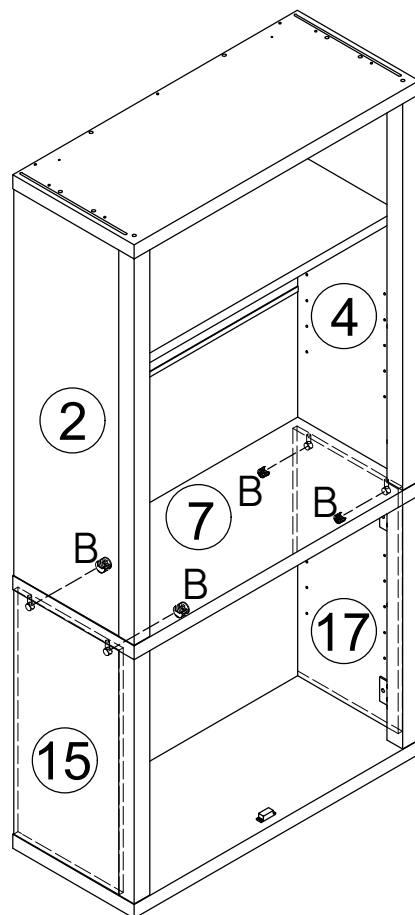

Step 25

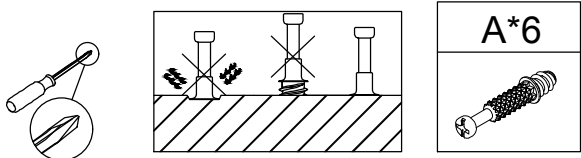
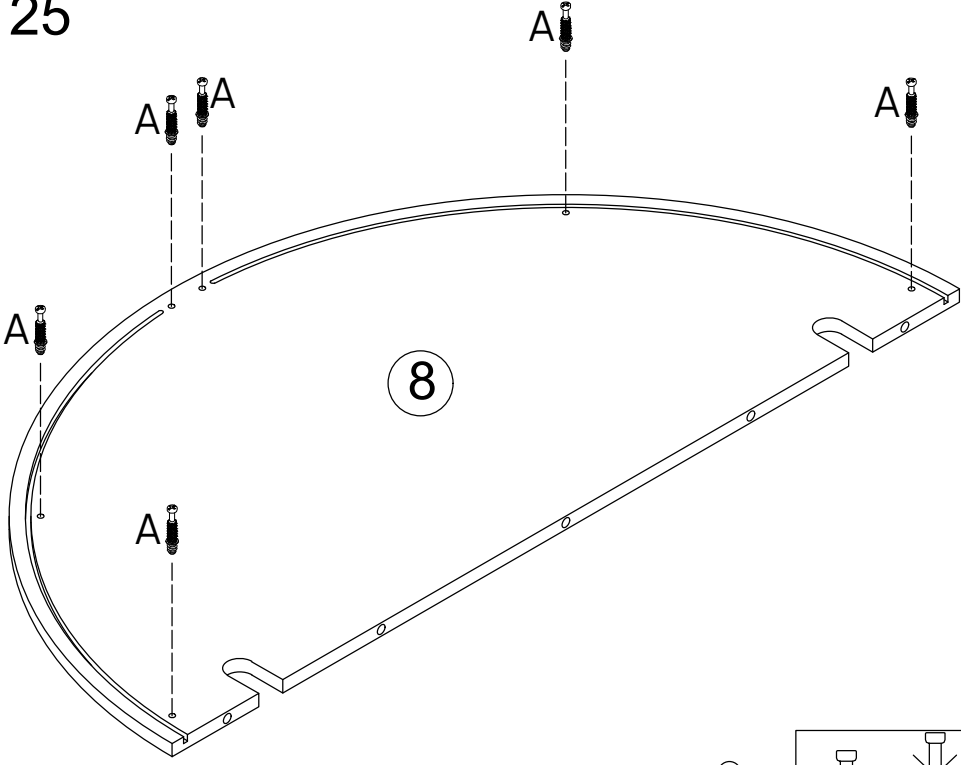

Step 26

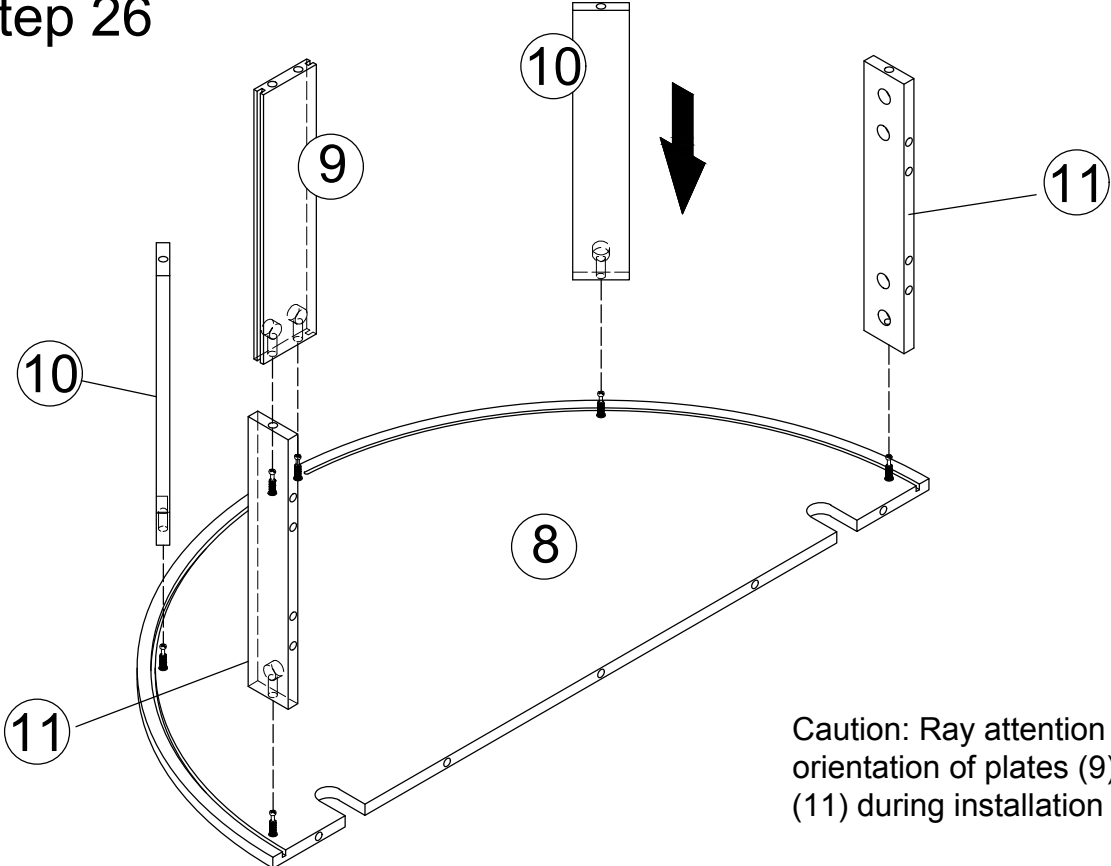

Caution: Ray attention to the orientation of plates (9),(10),and (11) during installation

Step 27

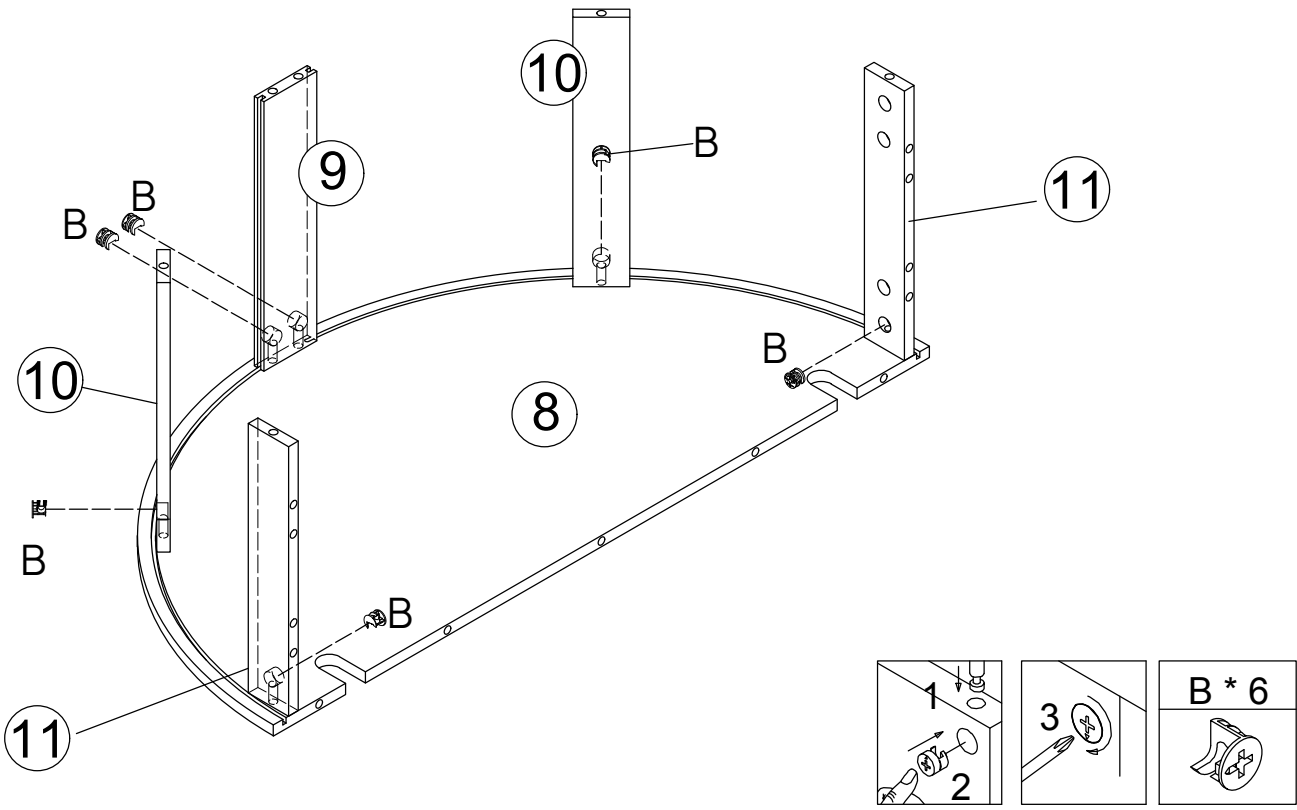

Step 28

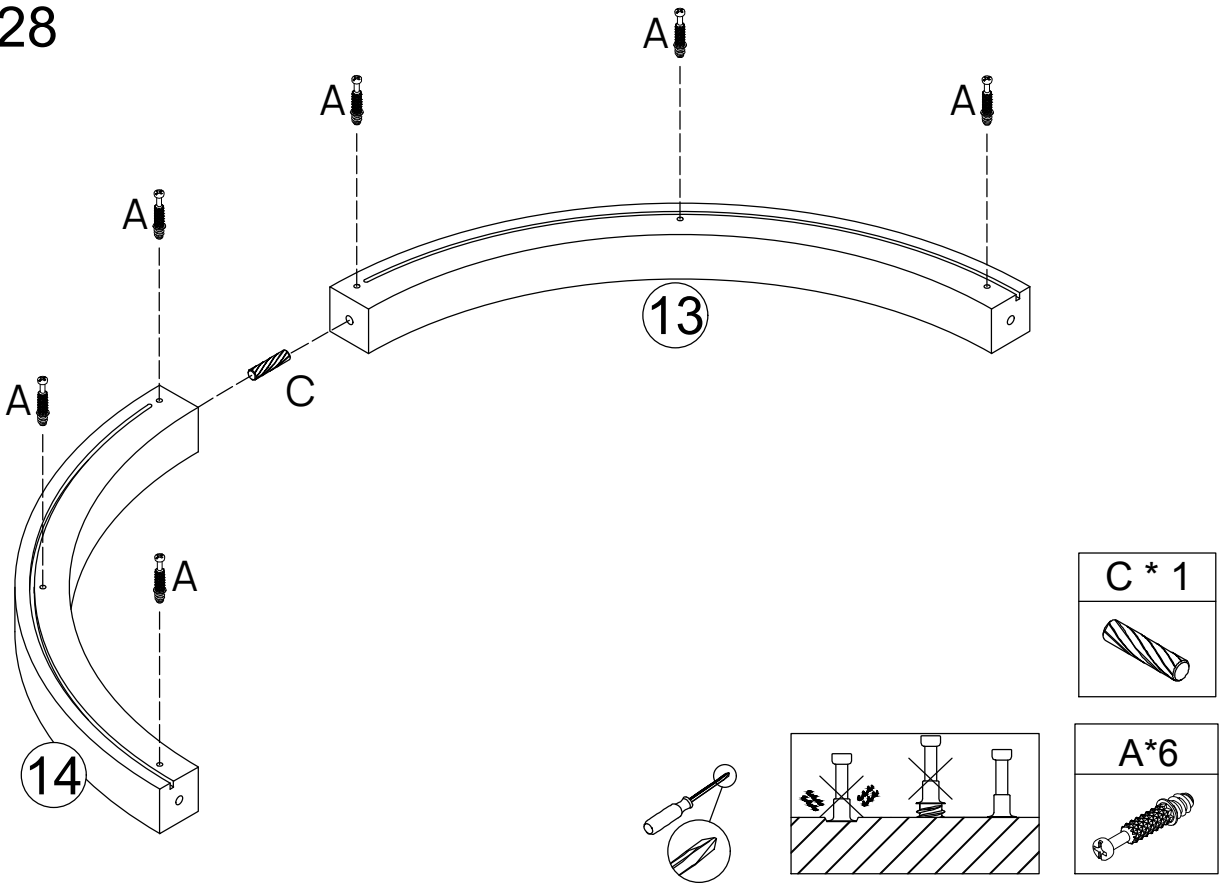

Step 29

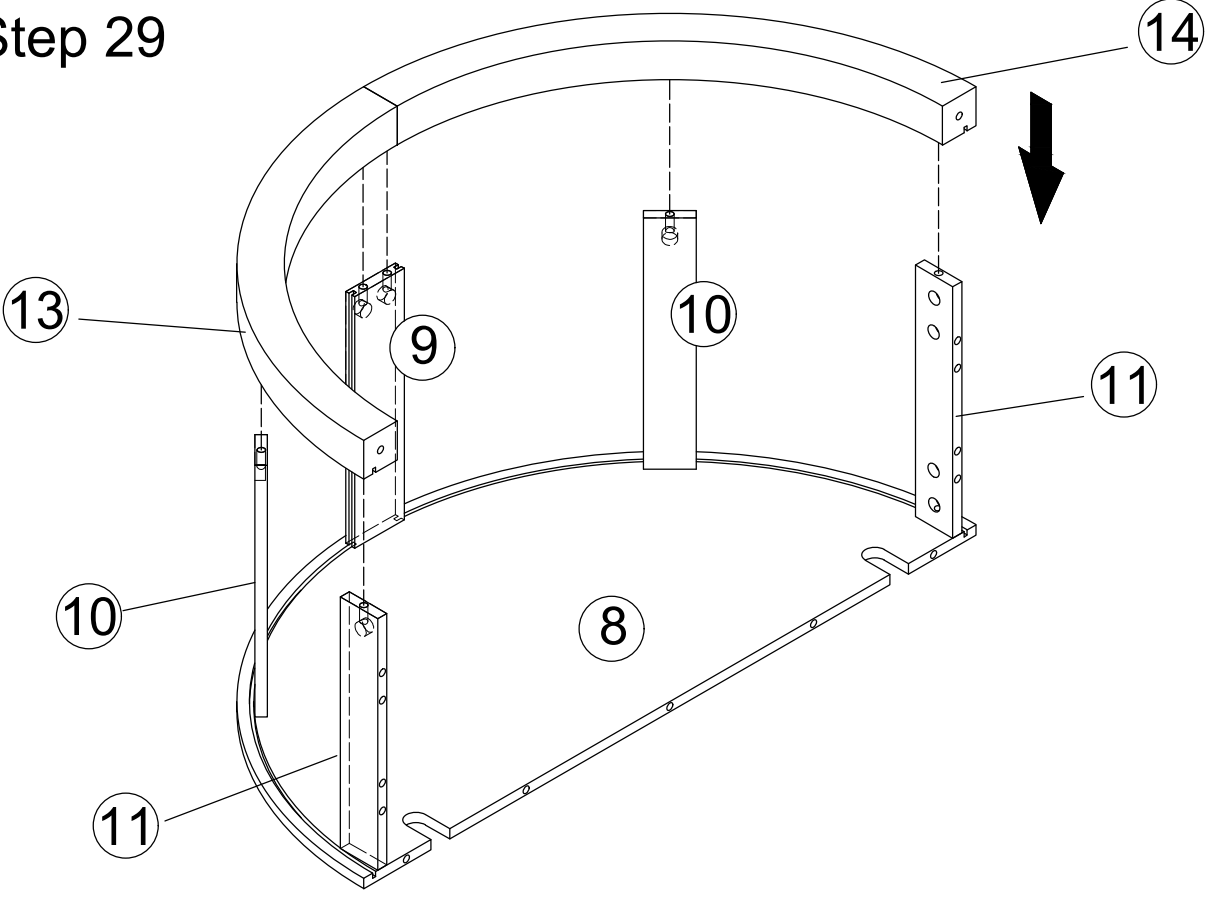

Step 30

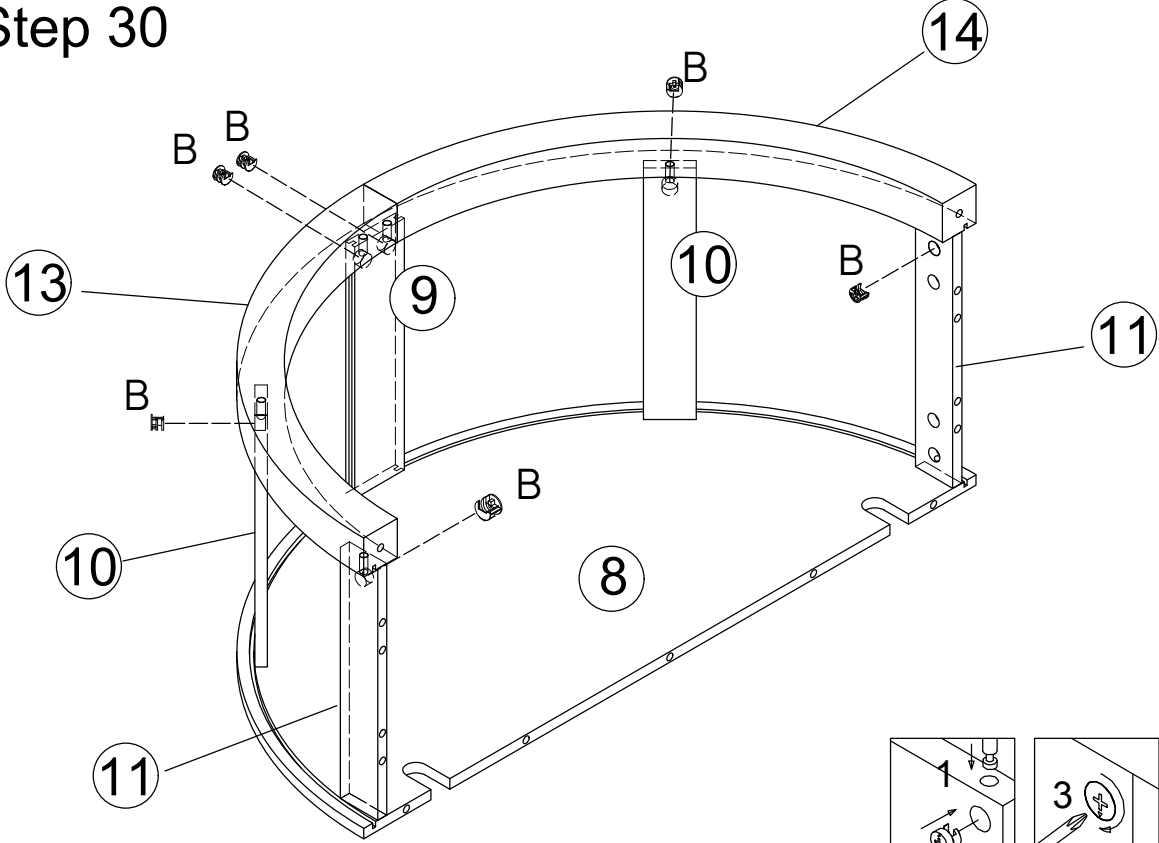

<p>1</p>	<p>2</p>	<p>3</p>	<p>B * 6</p> <p>B * 6</p>
----------	----------	----------	---------------------------

Step 31

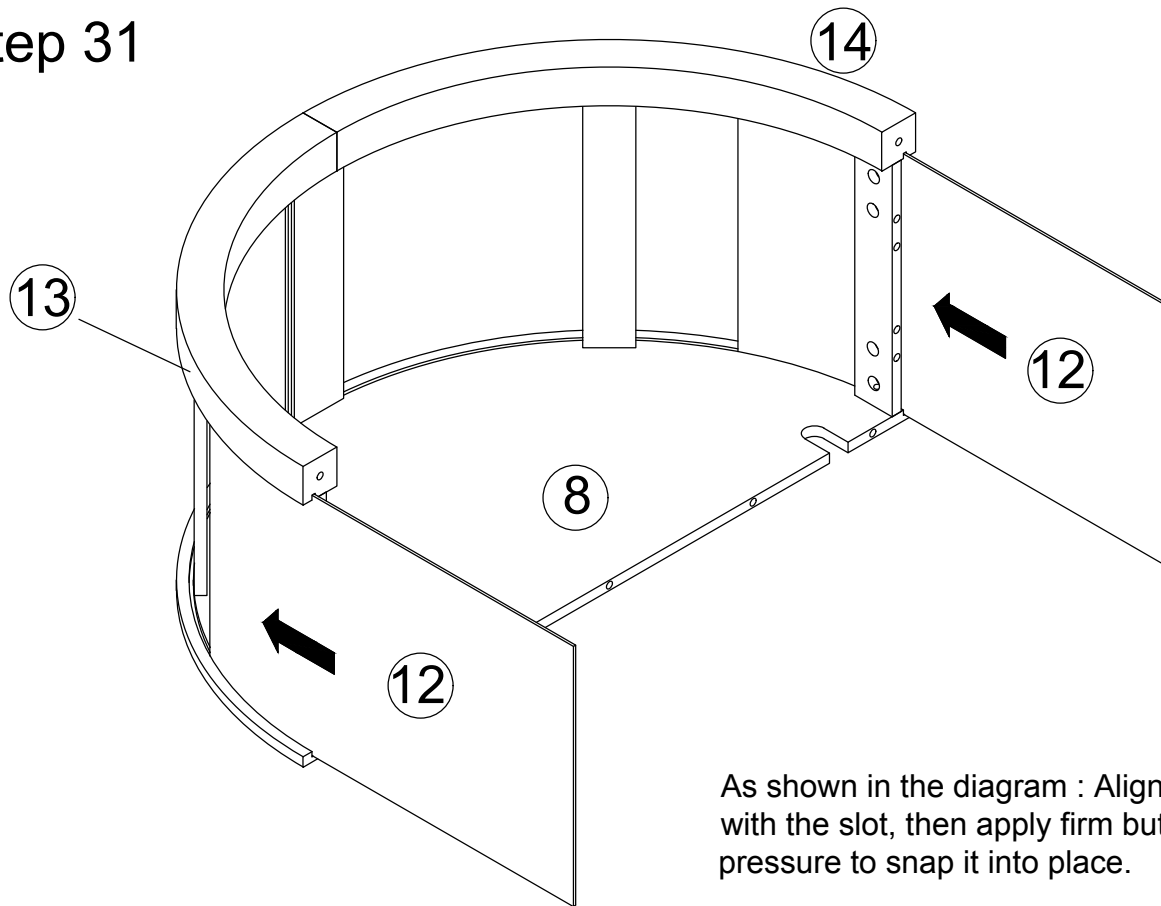

As shown in the diagram : Align Part 12 with the slot, then apply firm but gentle pressure to snap it into place.

Step 32

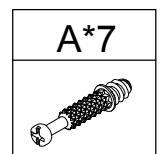
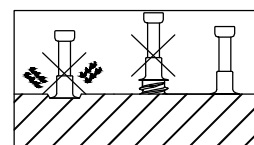
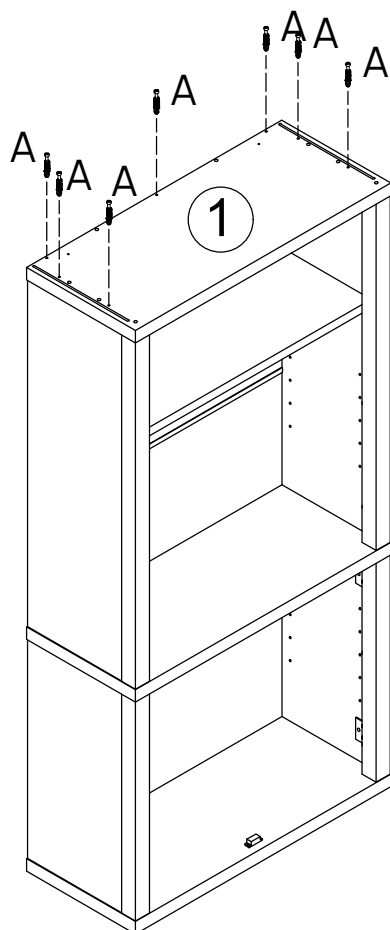

Step 33

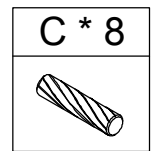
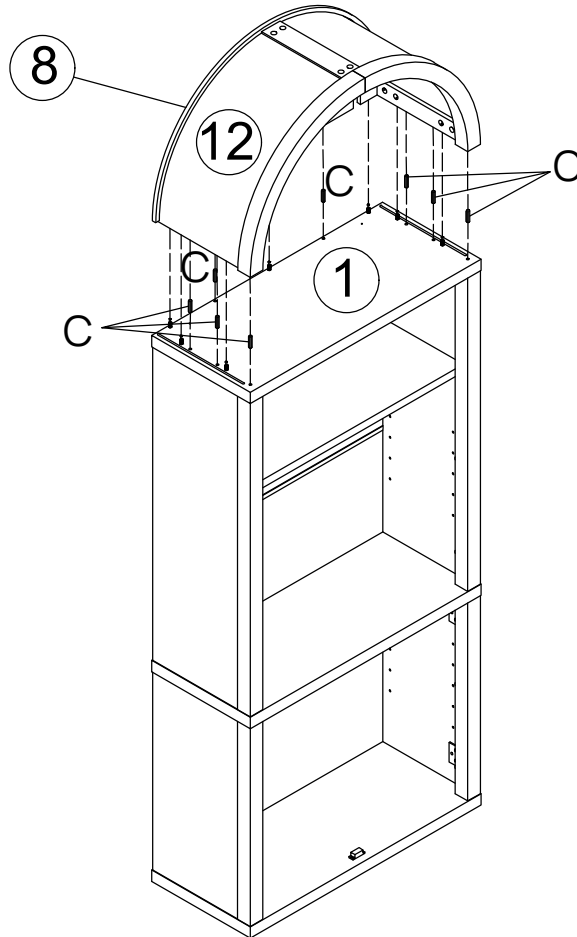

Step 34

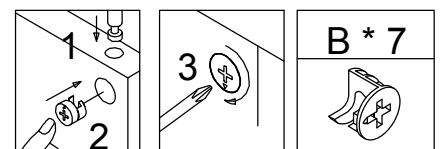
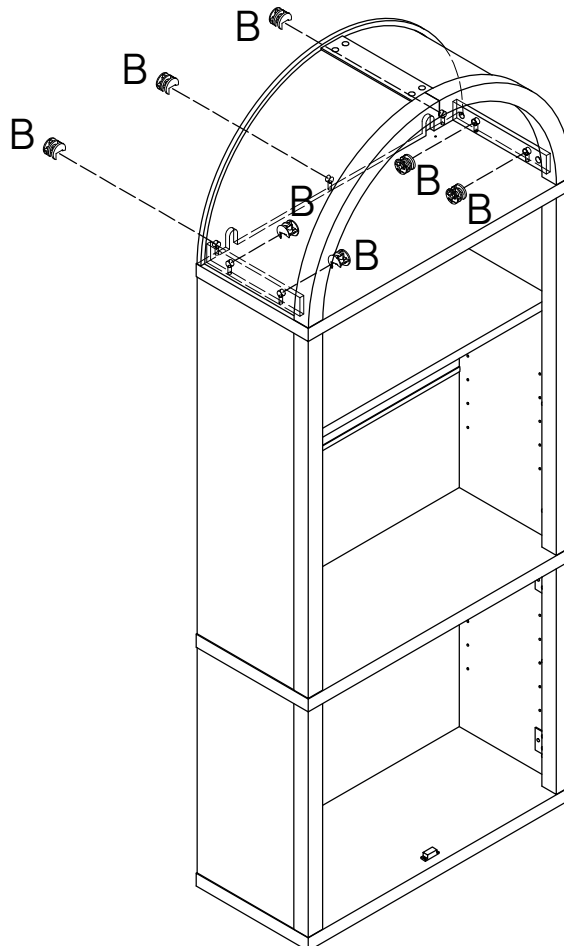

Step 35

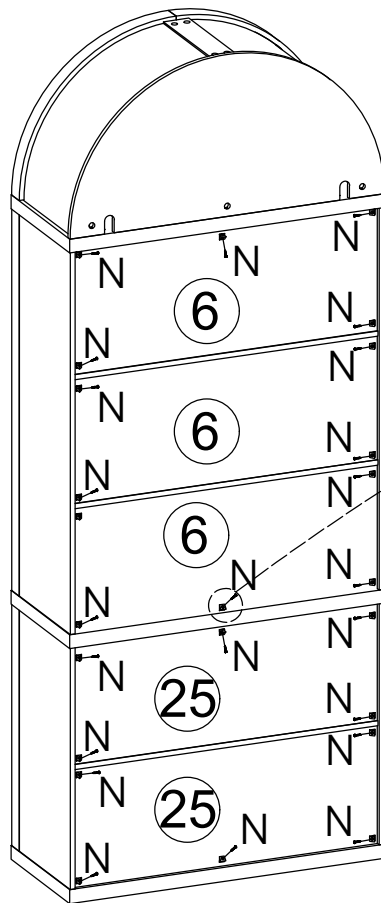

Must Be Installed

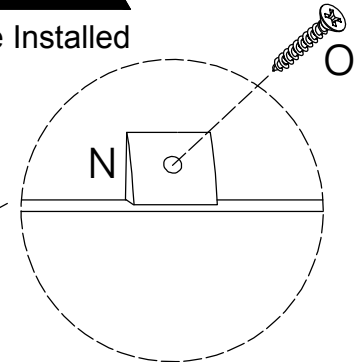

N * 24	O * 24

Step 36

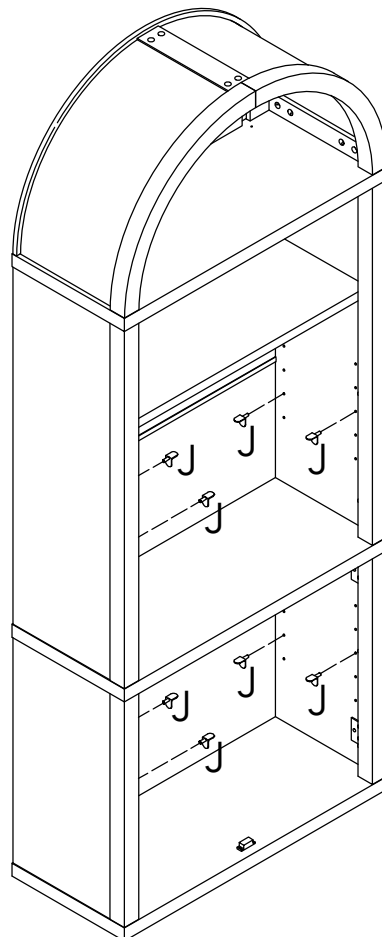

J * 8

Step 37

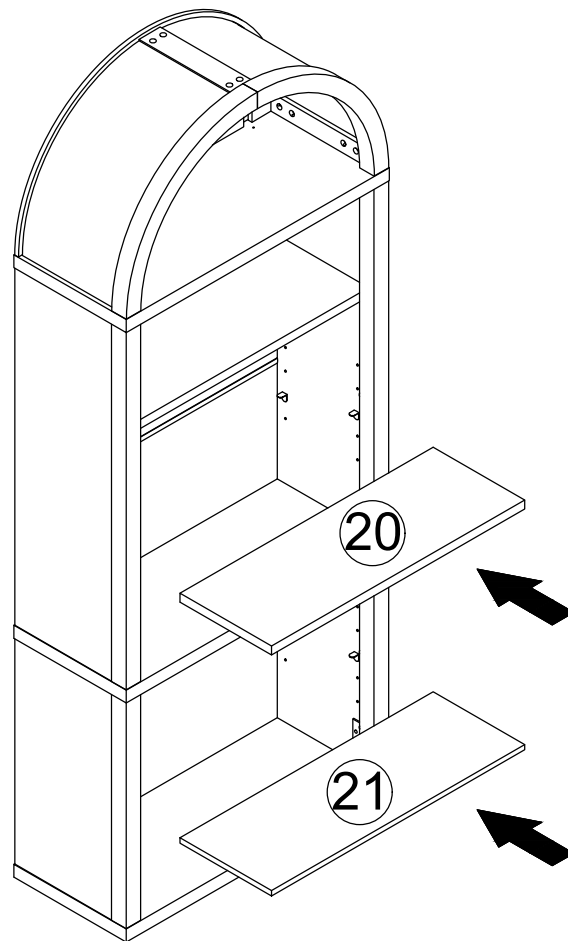

Step 38

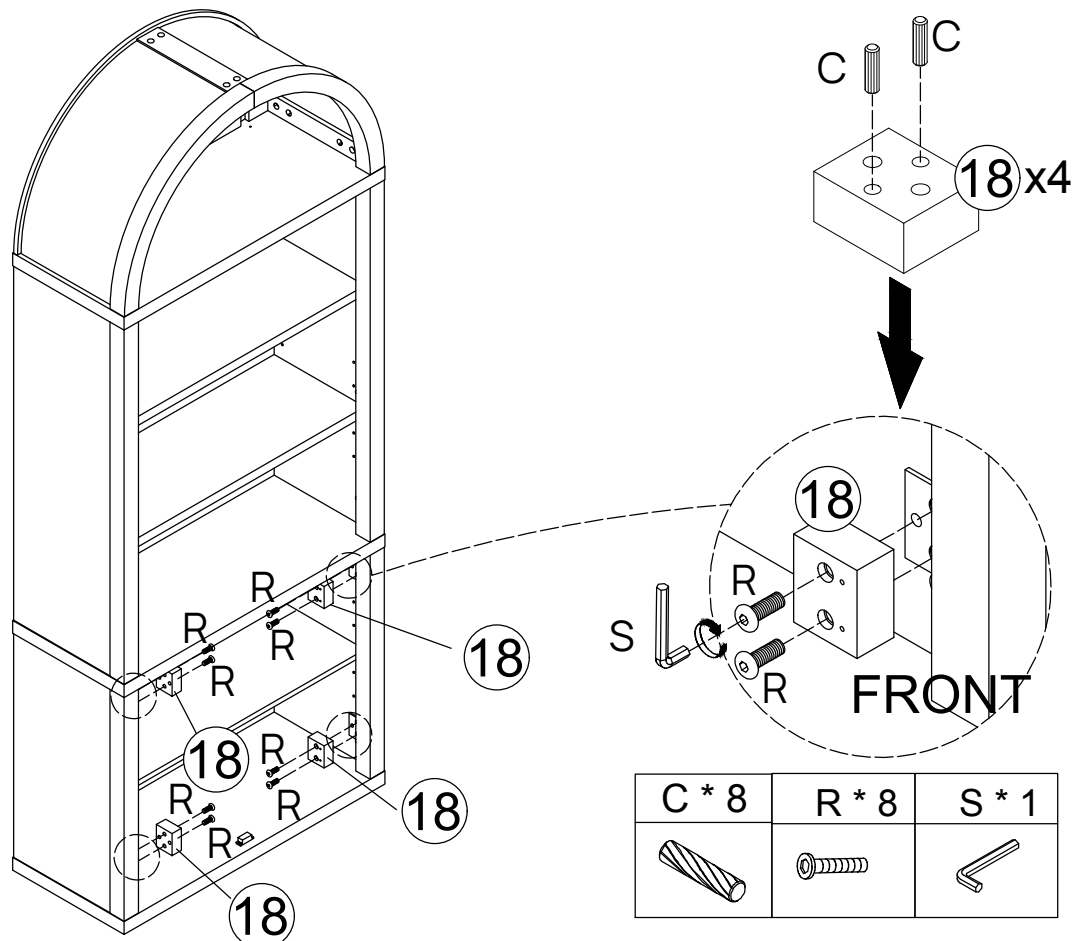

Step 39

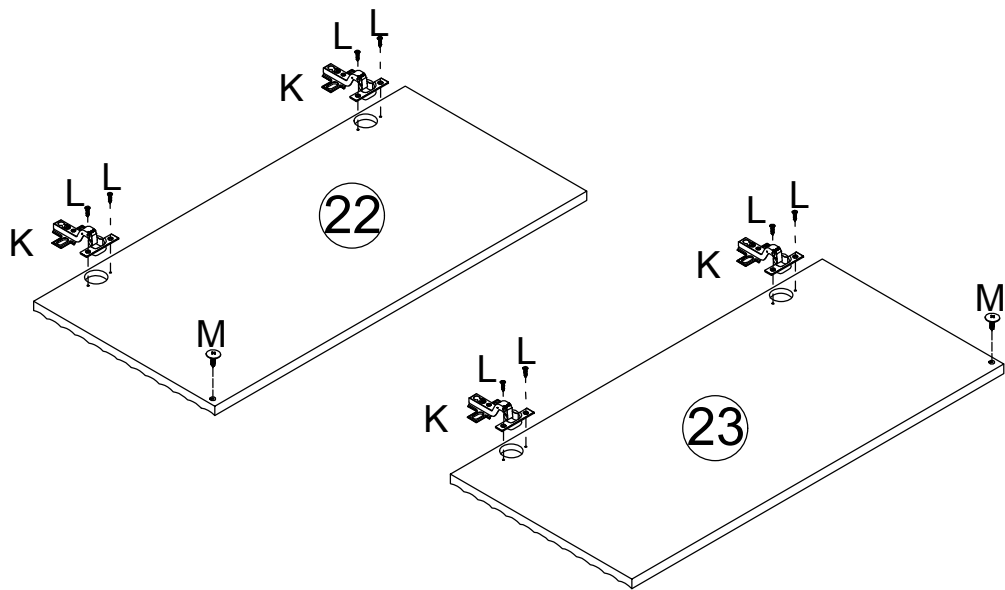

K * 4	L * 8	M * 2

Step 40

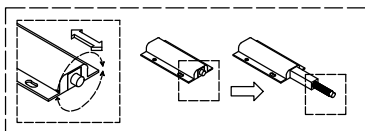

Note: You can adjust the knob of the bouncer to control the bouncing effect.

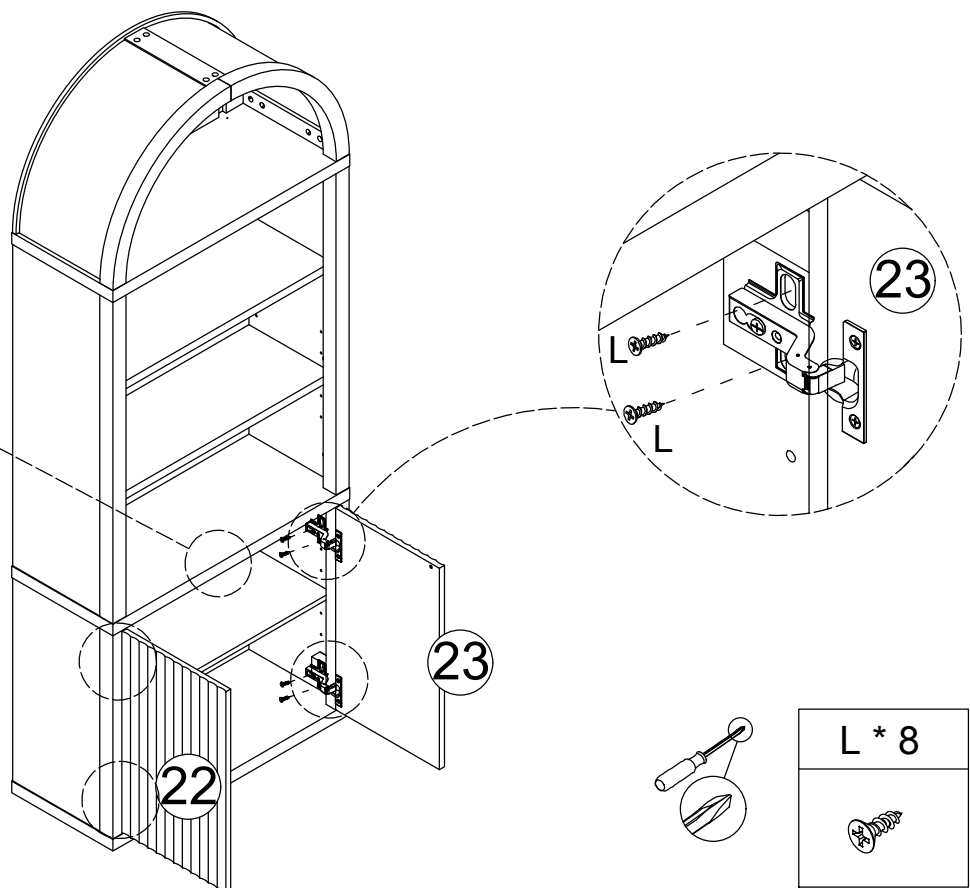

L * 8

Cabinet Door Adjustment Instructions

Height adjustment:

- Locate the height adjustment screws on the hinge.
- Use the Phillips screwdriver to either tighten or loosen the screws to raise or lower the cabinet door as desired.

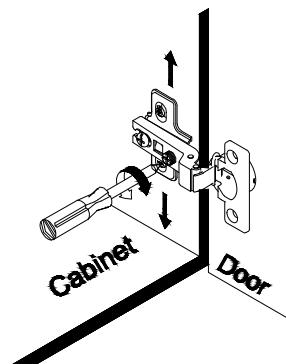
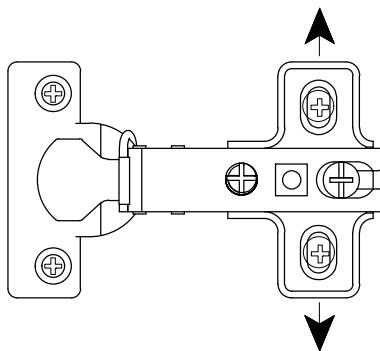
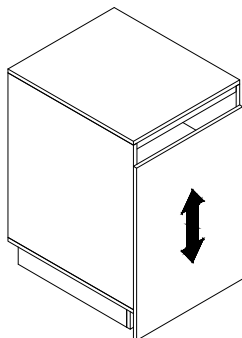

Side-to-side adjustment:

- If the cabinet door needs to be moved closer to or away from the cabinet frame, locate the side-to-side adjustment screws on the hinge.
- Use the Phillips screwdriver to adjust these screws and gradually move the door in the desired direction.

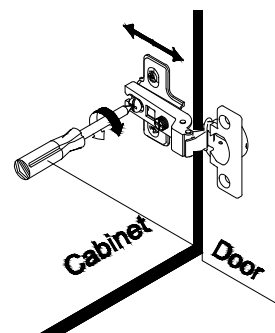
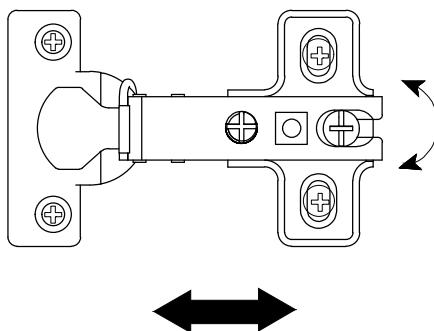
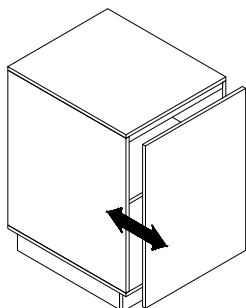

Depth adjustment (if applicable):

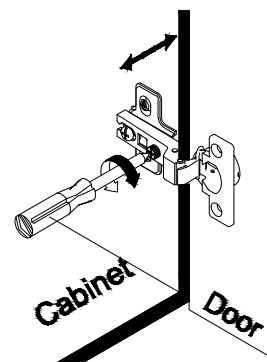
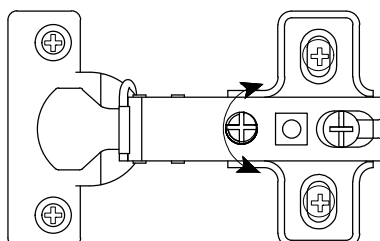
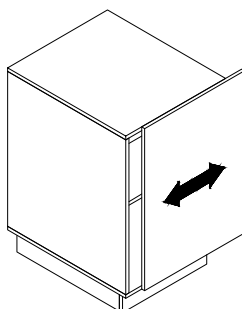

Step 41

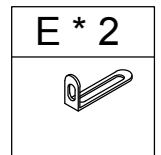
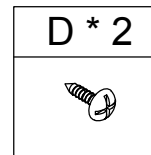
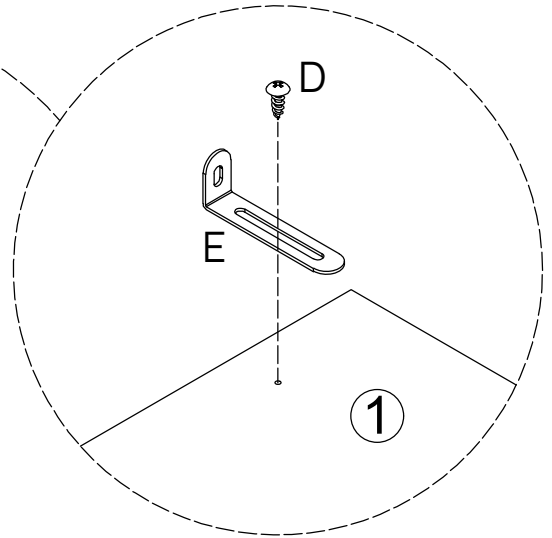
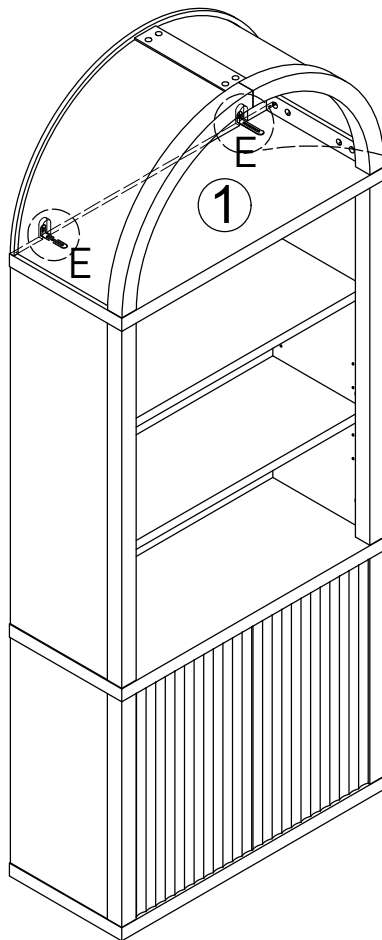

Step 42

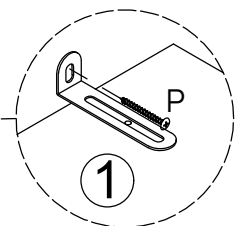
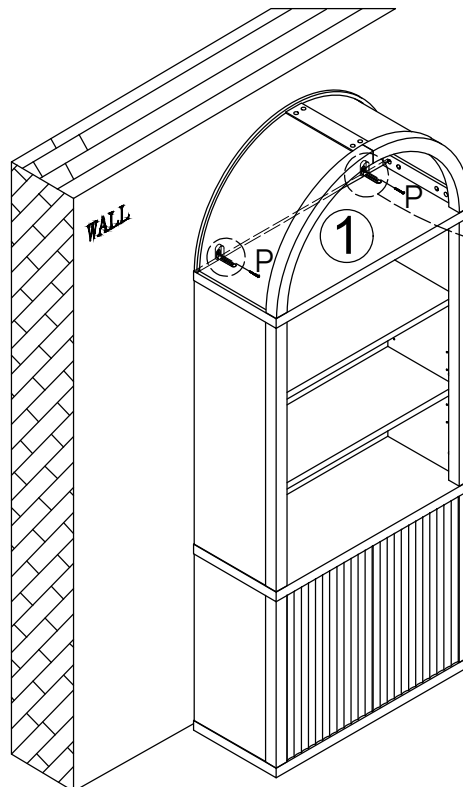
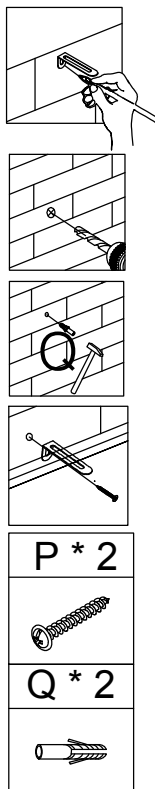

Step 43

208.9cm
82.24in

35cm
13.78in

82cm
32.28in

