





# ASSEMBLY INSTRUCTIONS | COFFEE TABLE

## SMALL TABLE

HARDWARE CHECKLIST		
01		Allen Bolt M6x10 (16 pcs)
02		JCBS M6x15 Bolt (4 pcs)
03		Spring Washer (4 pcs)
04		Flat Washer (4 pcs)
05		Allen Key (1 pc)

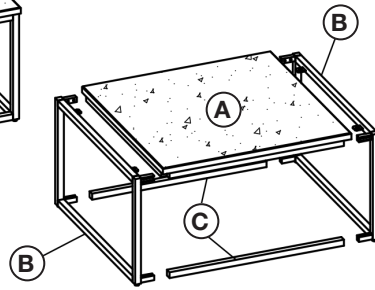
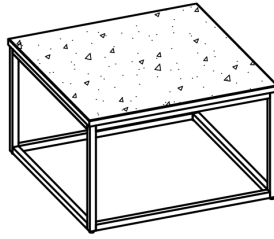

PARTS CHECKLIST	
A	Table Top (1 pc)
B	Metal Leg (2 pcs)
C	Bottom Stretcher (2 pcs)

Please do not begin assembly or discard any packaging until you have checked that all the parts and hardware are present. Follow instructions closely as deviation from them may void your warranty and present a possible safety risk. It is recommended that assembly is done on a soft surface to avoid any damage. Periodically check and re-tighten any fasteners. Wipe down all surfaces weekly with a clean cloth. Do not clean any surfaces with harsh abrasives or chemicals.

### Step 1

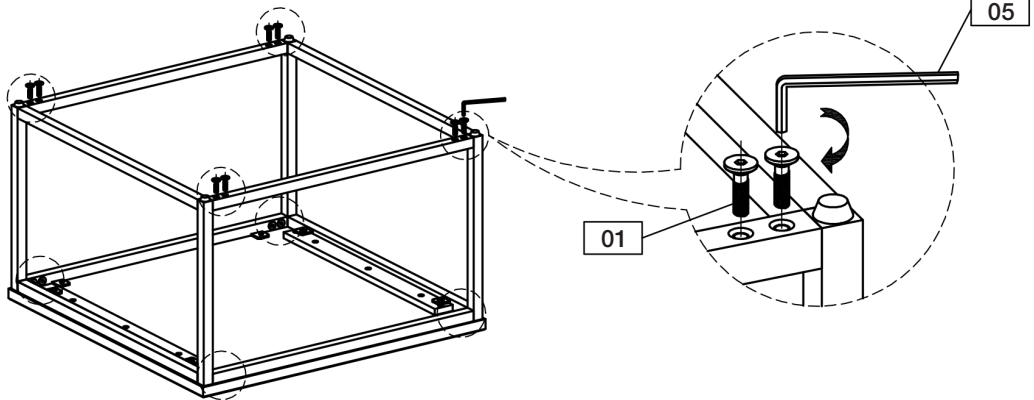

### Step 2

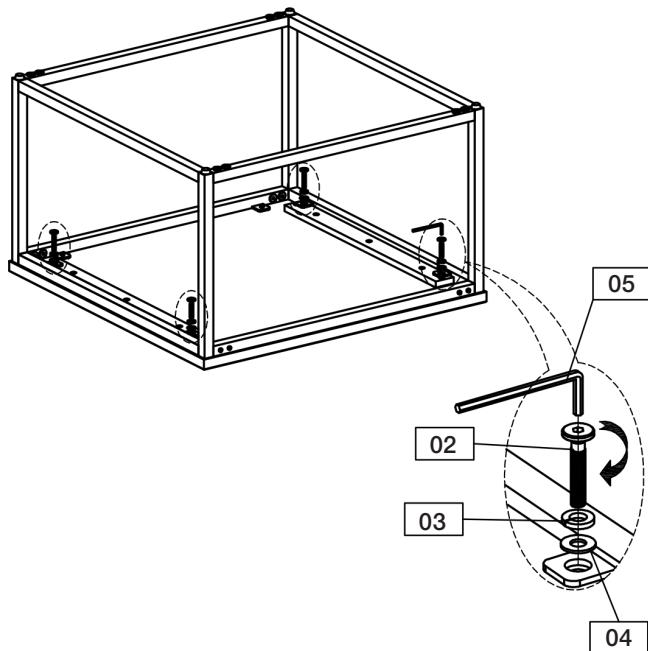



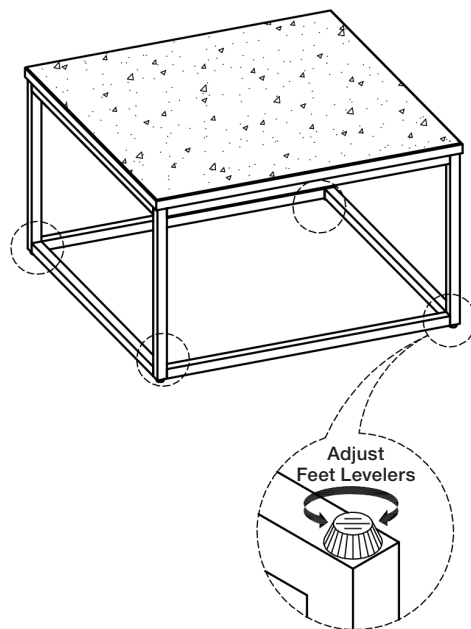

### Step 3



# ASSEMBLY INSTRUCTIONS | COFFEE TABLE

## LARGE TABLE

HARDWARE CHECKLIST		
01		Allen Bolt (16 pcs)
02		Bolt (6 pcs)
03		Spring Washer (6 pcs)
04		Flat Washer (6 pcs)
05		Allen Key (1 pc)

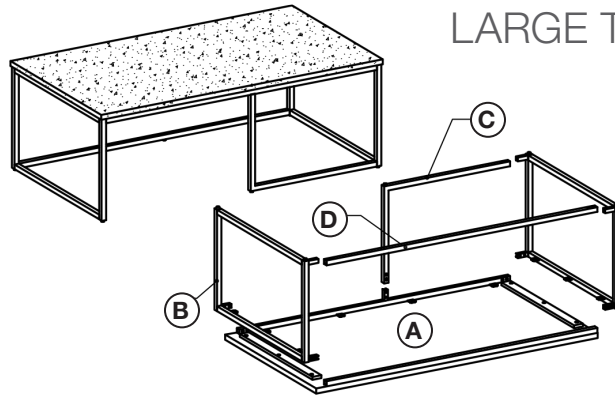

PARTS CHECKLIST	
A	Table Top (1 pc)
B	Metal Leg (2 pcs)
C	Front Stretcher (1 pc)
D	Back Stretcher (1 pc)

Please do not begin assembly or discard any packaging until you have checked that all the parts and hardware are present. Follow instructions closely as deviation from them may void your warranty and present a possible safety risk. It is recommended that assembly is done on a soft surface to avoid any damage. Periodically check and re-tighten any fasteners. Wipe down all surfaces weekly with a clean cloth. Do not clean any surfaces with harsh abrasives or chemicals.

### Step 1

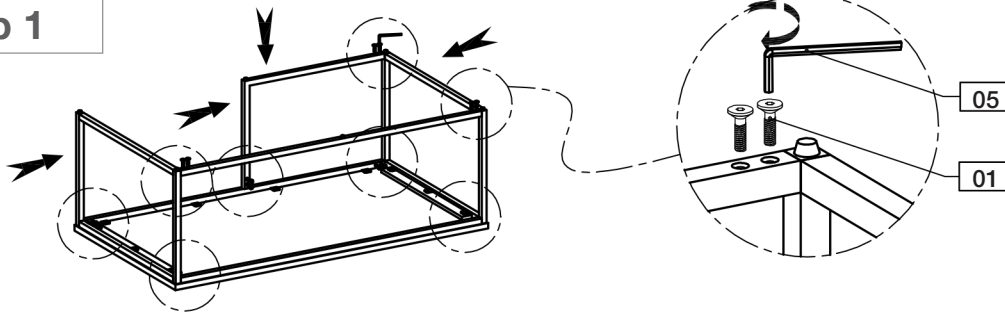

### Step 2

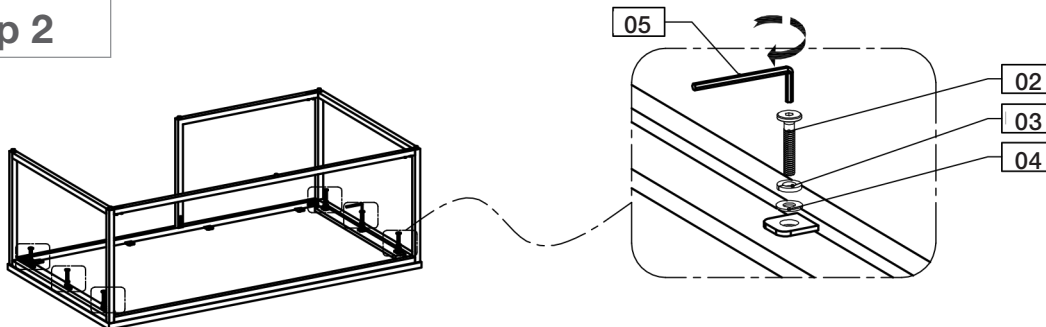

### Step 3

