

STEP 12

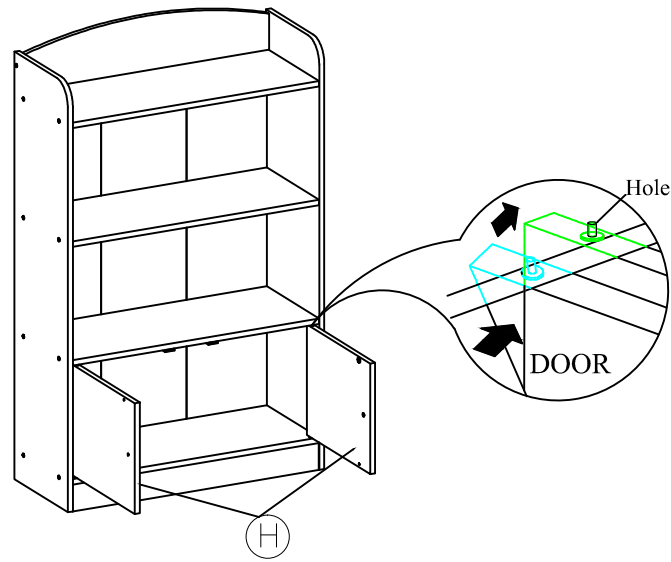

STEP 13

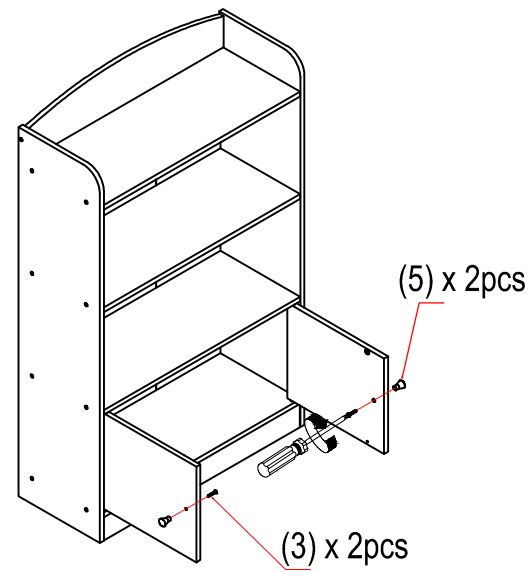

STEP 14

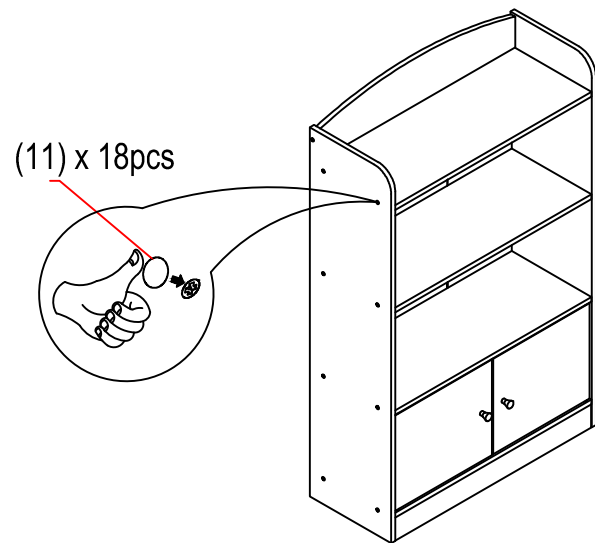

Recommended Maximum Weight

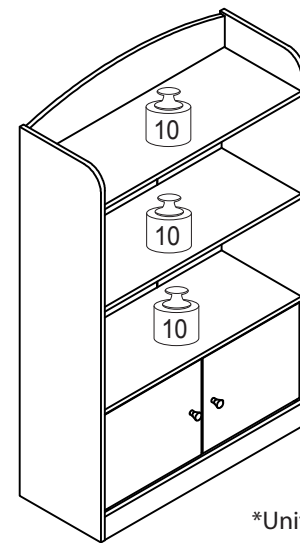

*Unit in Pound(lbs)

WARNING:

>This unit has been designed to support the maximum loads shown. Exceeding these load limits could cause sagging, instability, product collapse, and/or serious injury.

>DO NOT allow children to climb on unit.

>Put heavier items on lower shelves.

Assembly Instruction

Bookshelf With Storage Cabinet

00:30

Approx. 30 minutes





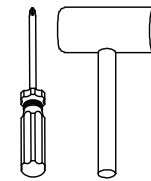



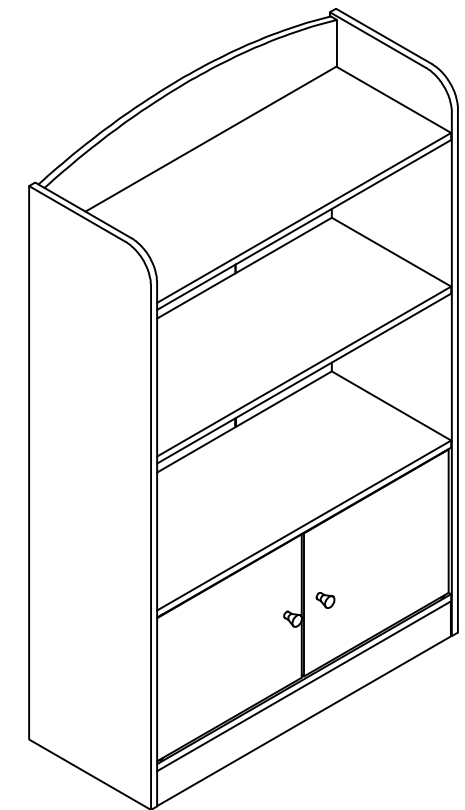



Recomm. 2 Person



Tool Required



NO	HARDWARE LIST	QTY
1	Long Screw 	18pcs
2	Short Screw 	4pcs
3	Middle Screw 	2pcs
4	Dowel 	2pcs
5	Handle 	2pcs
6	Door Support 	4pcs
7	Magnet 	2pcs
8	Tapping Screw 	2pcs
9	L Bracket 	2pcs
10	Power Pin 	20pcs
11	Round Sticker 	18pcs

NO	PARTS LIST	QTY
A	LEFT SIDE PANEL	1pc
B	RIGHT SIDE PANEL	1pc
C	BOTTOM PANEL	1pc
D	FRONT SUPPORT PANEL	1pc
E	LOWER SHELF PANEL	1pc
F	SHELF PANEL	2pcs
G	BACK SUPPORT PANEL	1pc
H	LEFT / RIGHT DOOR PANEL	2pcs
I	BACK PANEL	3pcs

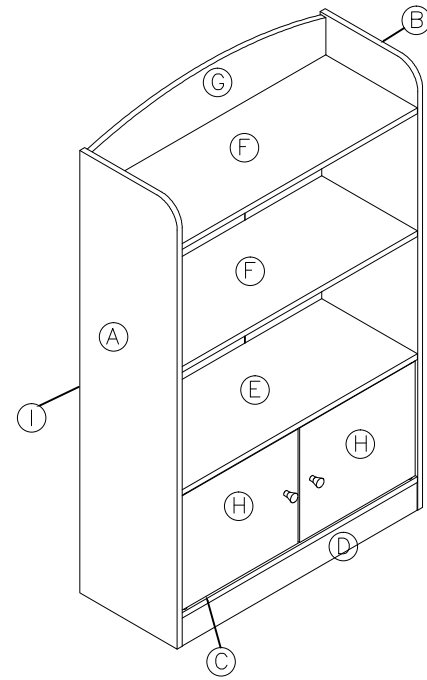

USEFUL HINTS BEFORE YOU START:

1. Read each step carefully before starting.
2. It is important that each step is performed in correct order to avoid difficulties.
3. Identify, sort and count the parts before assembly.
4. Assemble your furniture on packaging cardboard to prevent scratch or damage.
5. Clean the product with mild cleanser using soft damped cloth. Do not use harsh or abrasive cleanser.
6. Using incompatible hardware might cause damage to product.

STEP 5

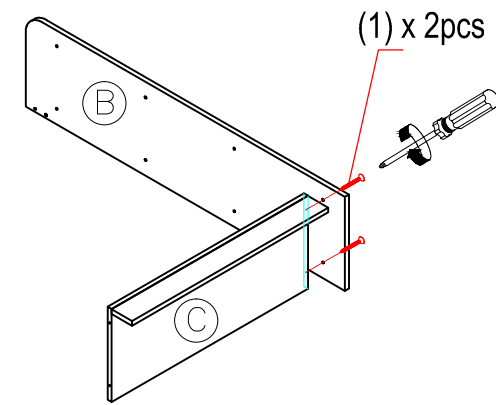

STEP 7

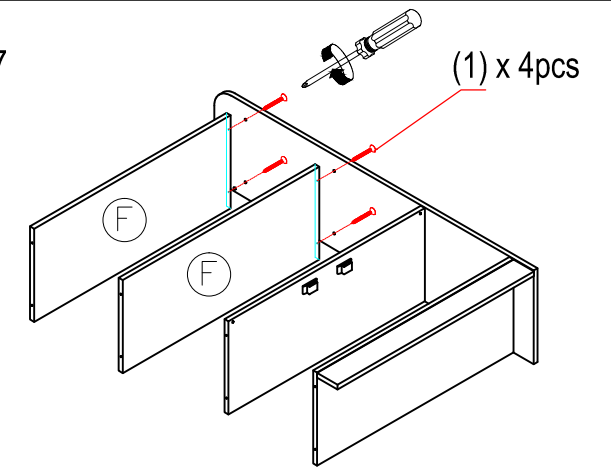

STEP 6

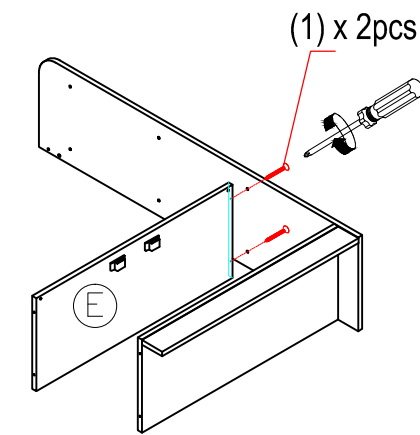

STEP 8

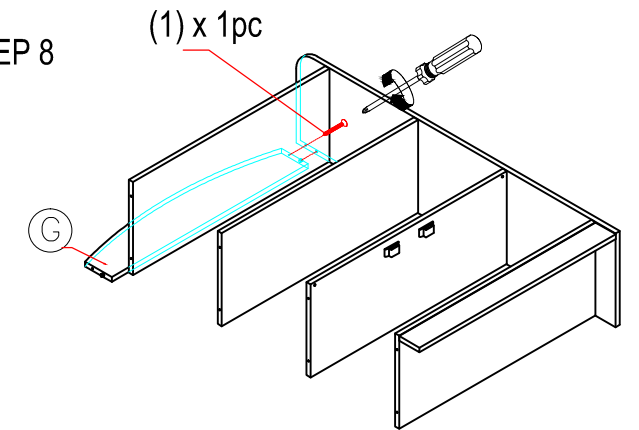

STEP 1

ASSEMBLY INSTRUCTION

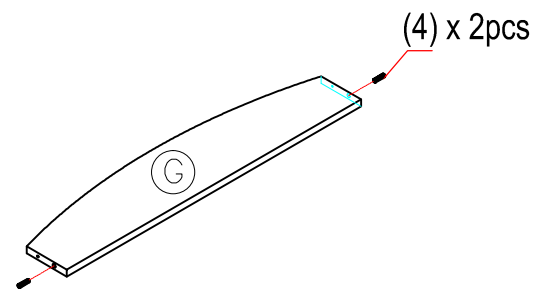

STEP 3

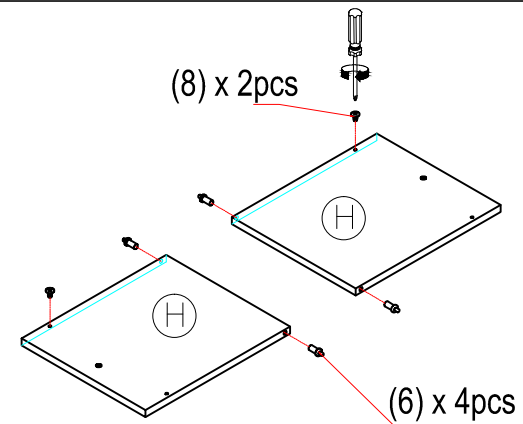

STEP 9

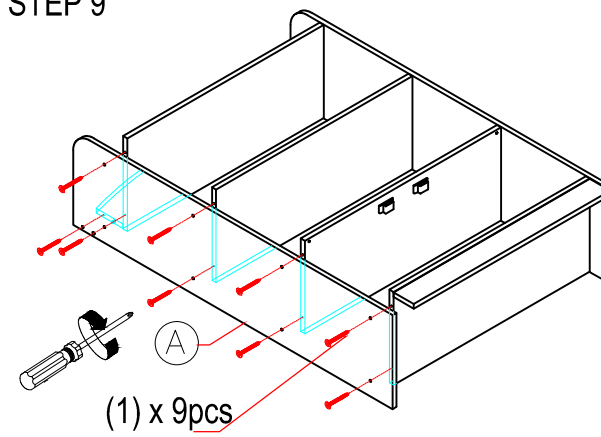

STEP 11

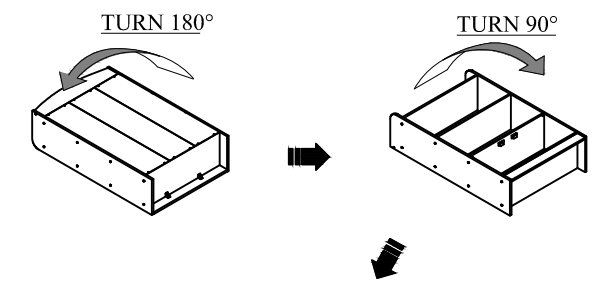

STEP 2

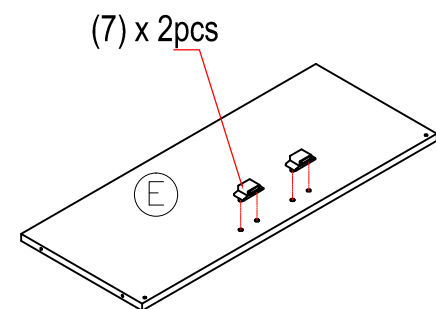

STEP 4

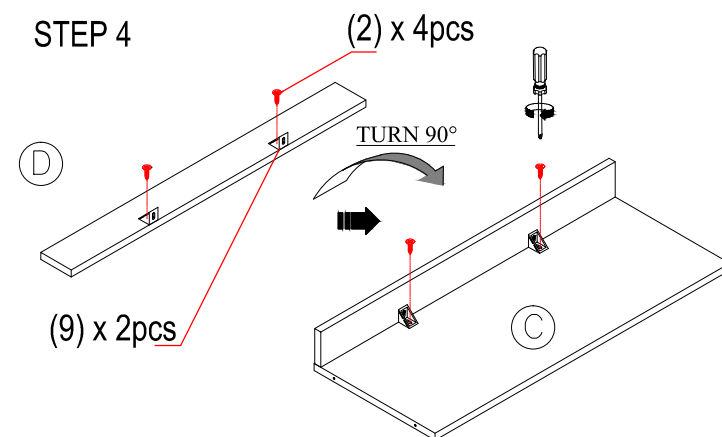

STEP 10

