

3 DRAWER BEDSIDE TABLE ASSEMBLY INSTRUCTIONS

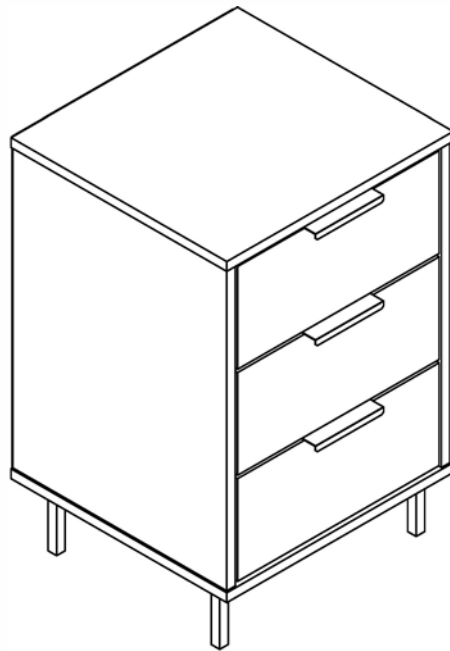

IMPORTANT
FOR DOMESTIC USE ONLY
PLEASE READ BEFORE YOU CONTINUE FURTHER

CARE AND MAINTENANCE

After unpacking this product please keep the original packaging in case it needs to be returned for any reason.

- Please ensure all fittings and parts are present before commencing with assembly.
- Never drag or push products as this could cause damage to the joints making it inferior.
- We strongly recommend that you keep children away from your work area.
- We recommend that you lay a blanket or sheet on the floor to avoid damage to both your floor and the product.
- Assemble this product as close to its final position as possible.
- Do not place this product next to a radiator or in direct sunlight.
- Do not drag or push items across your high gloss furniture as this may cause the surface to scratch
- Wood is a natural product and may expand if subjected to damp and may shrink or crack if subjected to heat. Therefore it is recommended that room temperature is maintained, with no sudden temperature fluctuations.
- Make sure any spillage is wiped off immediately.
- Do not place hot or chilled items directly on to the surface, use a place mat or marking will occur.
- For general cleaning use a soft cotton or micro fibre cloth, and do not use detergents of any kind.
- From time to time it may be necessary to tighten fittings, regular inspections should be carried out.
- Do not place on a wet or damp floor as staining may occur to your floor.

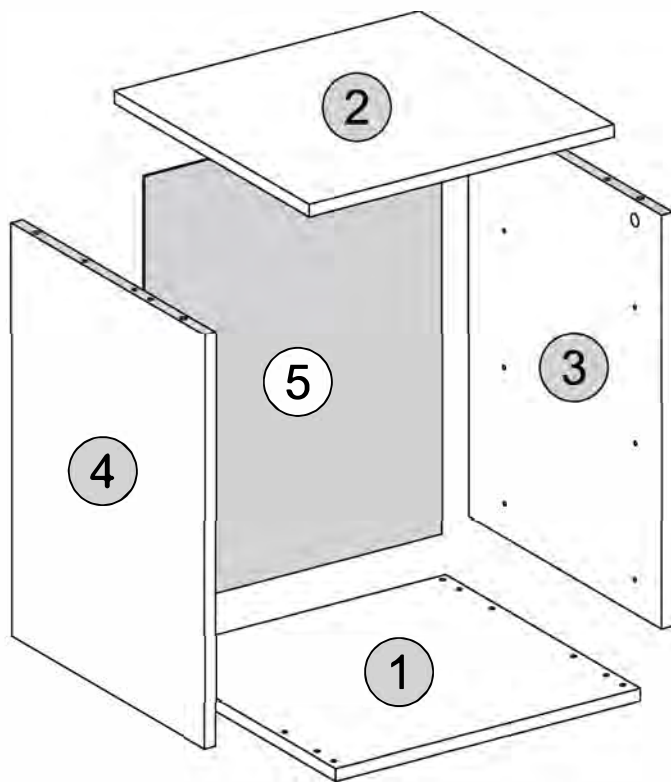

TOOLS REQUIRED

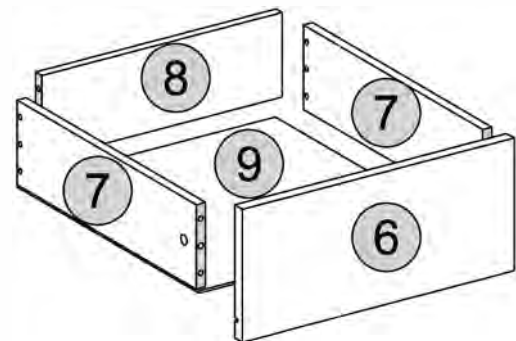
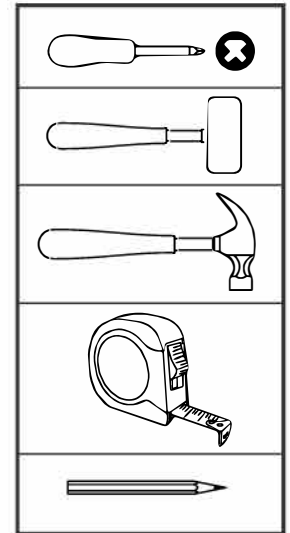











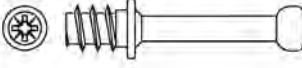

PARTS LIST

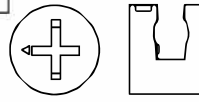
Please Note:
The below parts have all been stamped with the part number to help identify them during assembly.

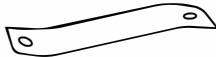
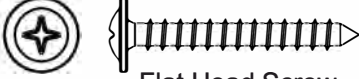
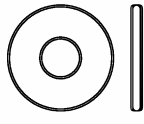
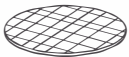
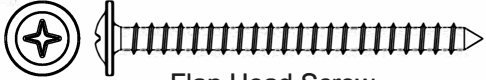
Part Number	Part Description	Quantity	Carton
01	Base Panel	1	1/1
02	Top Panel	1	1/1
03	Right Side Panel	1	1/1
04	Left Side Panel	1	1/1
05	Back Panel	1	1/1
06	Drawer Front	3	1/1
07	Drawer Side	6	1/1
08	Drawer Back Panel	3	1/1
09	Drawer Bottom	3	1/1

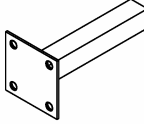
FITTINGS LIST

A  Flat Head Screw +/2 Ø6,0 x 10mm (12x)	B  Flat Head Screw +/2 Ø4,0 x 14mm (32x)	C  Flat Head Screw +/1 Ø4,0 x 50mm (6x)	D  +/2 Dowel Ø6,0 x 30mm (32x)	
E  +/3 Nail 10 x 10 (45x)	F  +/2 Cam Bolt (10x)	G  +/2 Cam Nut (6x)	H  +/1 Cam Nut (4x)	I  Glue (1x)
J  Strap (1x)	K  +/1 Flat Head Screw Ø3,5 x 30mm (1x)	L  +/1 Washer (2x)	M  +/2 Hole Plugs (10x)	
N  +/1 Flan Head Screw Ø4 x 50mm (8x)	O  +/1 Internal Tip (4x)	P  Handle (3x)	Q  Tubular Foot (4x)	
R  Drawer Runners (3x)				

TIPS FOR FITTINGS CAM-LOCKS

WHEN FITTING CAM NUT, ENSURE STARTING POSITION IS CORRECT BEFORE YOU INSERT CONNECTING CAM BOLT TURN CLOCKWISE UNTIL SECURE

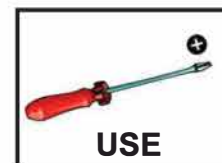
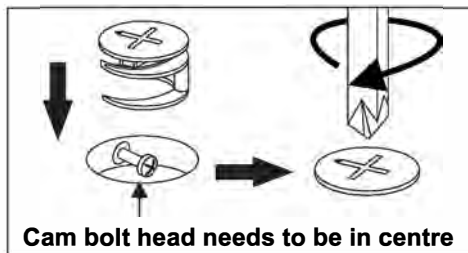
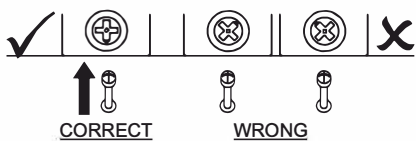

CAMBOLT
 Tighten until shoulder in flush with panel. Do not overtighten or undertighten (see example beside)

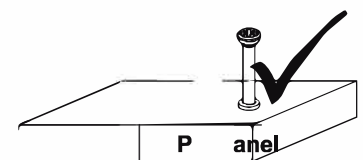
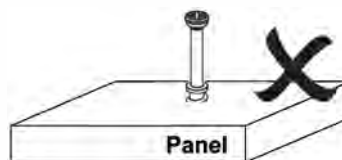
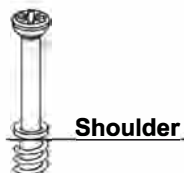

STEP 1

PARTS REQUIRED

3 - RIGHT SIDE PANEL x1

4 - LEFT SIDE PANEL x1

HARDWARE REQUIRED

D  08

I  01

TOOLS REQUIRED

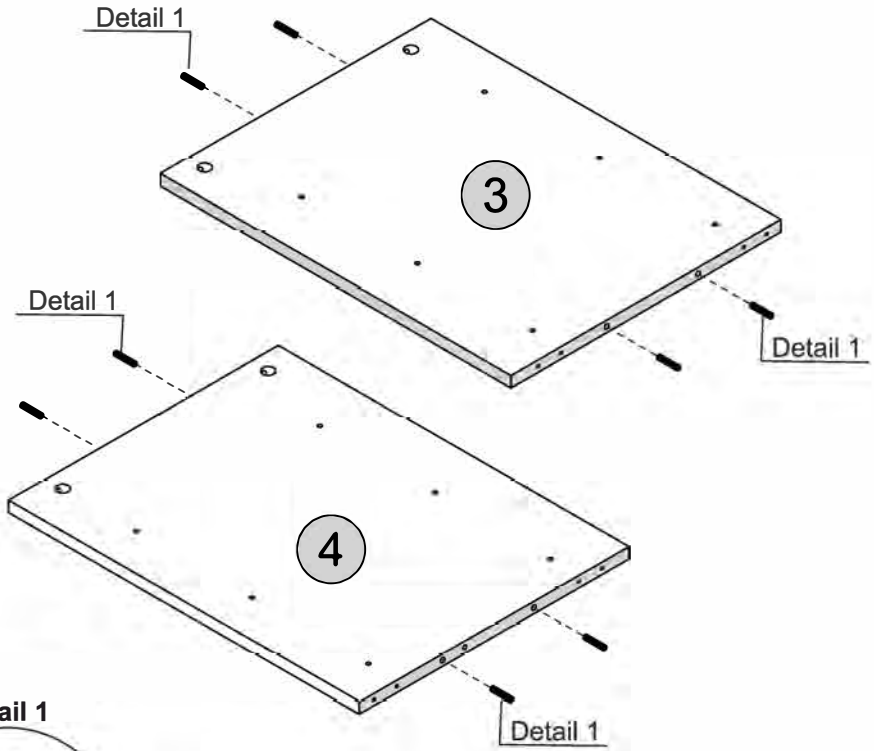
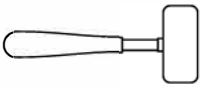

STEP 2

PARTS REQUIRED

3 - RIGHT SIDE PANEL x1

4 - LEFT SIDE PANEL x1

HARDWARE REQUIRED

A  12
Ø6,0 x 10mm

R  03

TOOLS REQUIRED

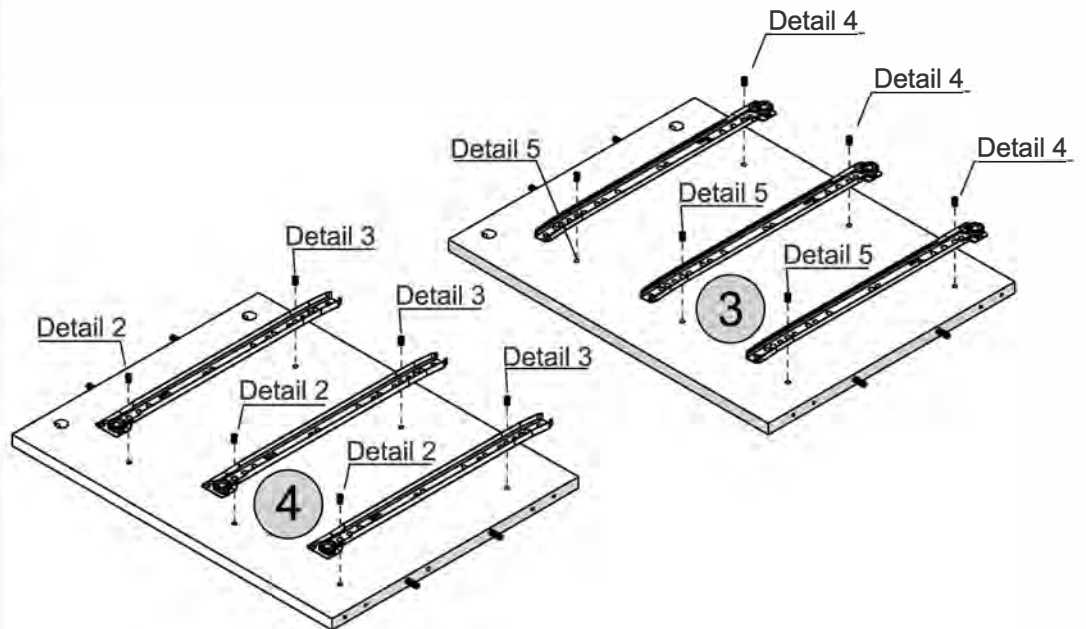
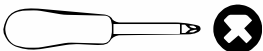

Please note
pre-drilled holes

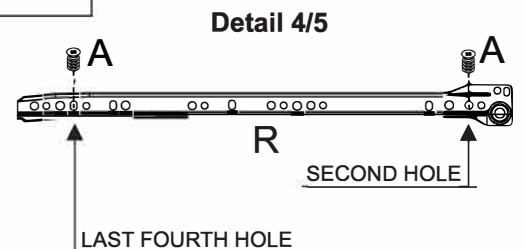
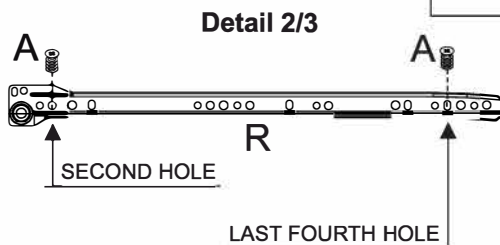

STEP 3

PARTS REQUIRED

2 - TOP PANEL x1

HARDWARE REQUIRED

F  04

O  04

Q  04

TOOLS REQUIRED

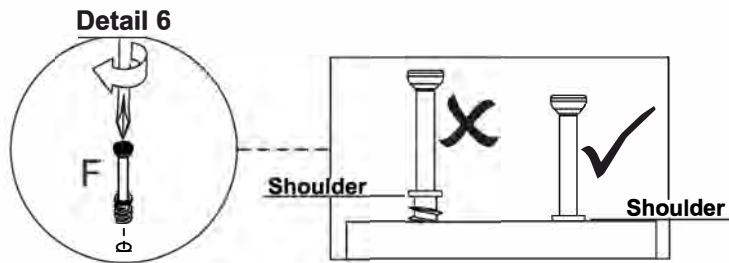
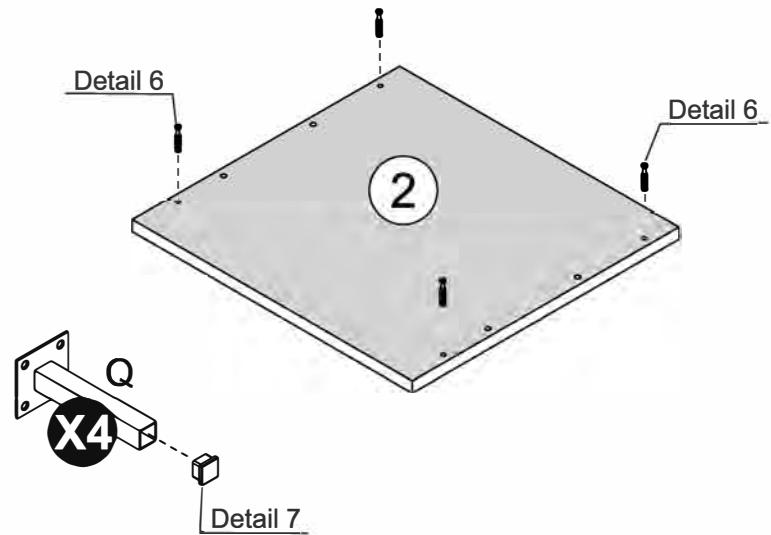
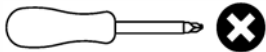

STEP 4

PARTS REQUIRED

2 - TOP PANEL x1

3 - RIGHT SIDE PANEL x1

4 - LEFT SIDE PANEL x1

HARDWARE REQUIRED

H  04

M  04

TOOLS REQUIRED

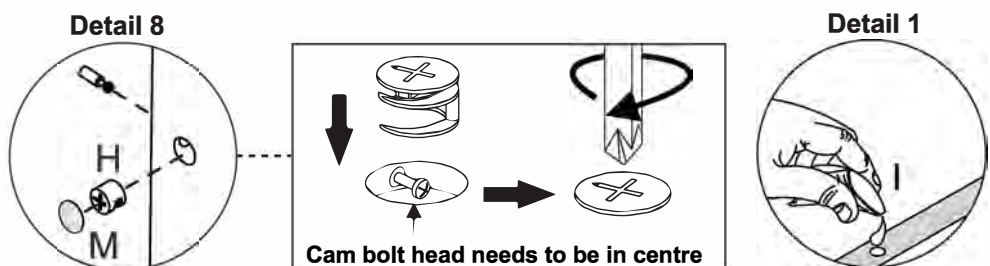
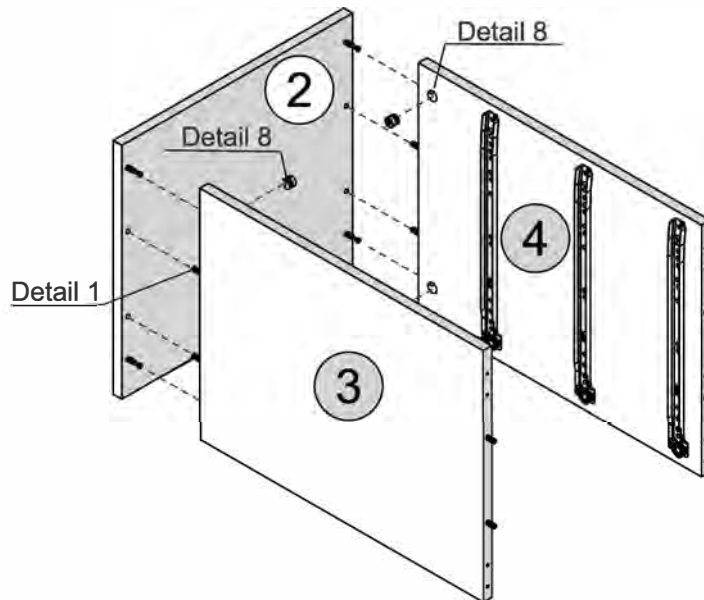

STEP 5

PARTS REQUIRED

1 - BASE PANEL x1

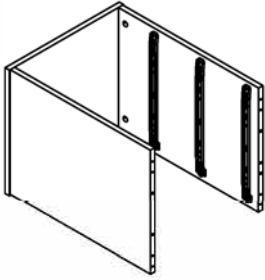

HARDWARE REQUIRED

N  08
Ø4,0 x 50mm

Q  04

TOOLS REQUIRED

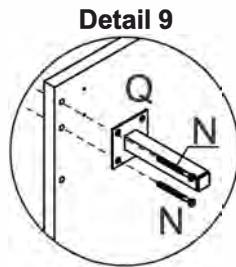
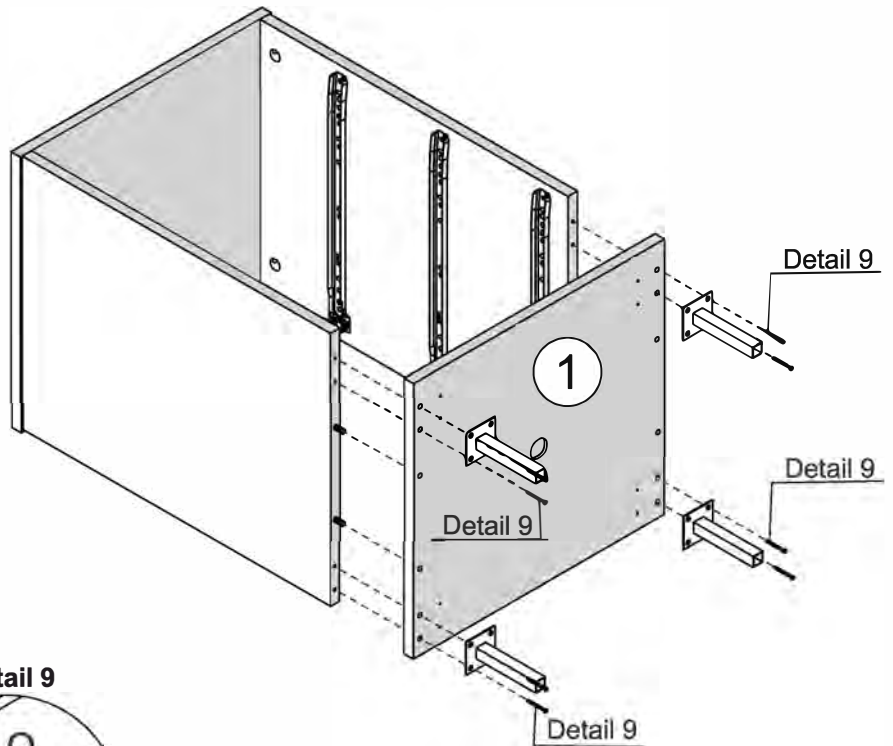

STEP 6

PARTS REQUIRED

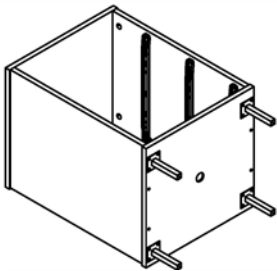

HARDWARE REQUIRED

B  08
Ø4,0 x 14mm

TOOLS REQUIRED

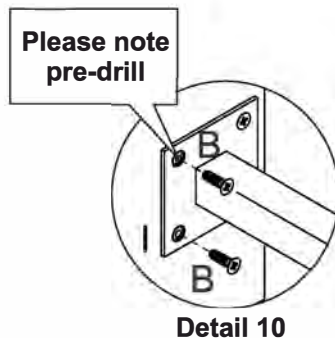
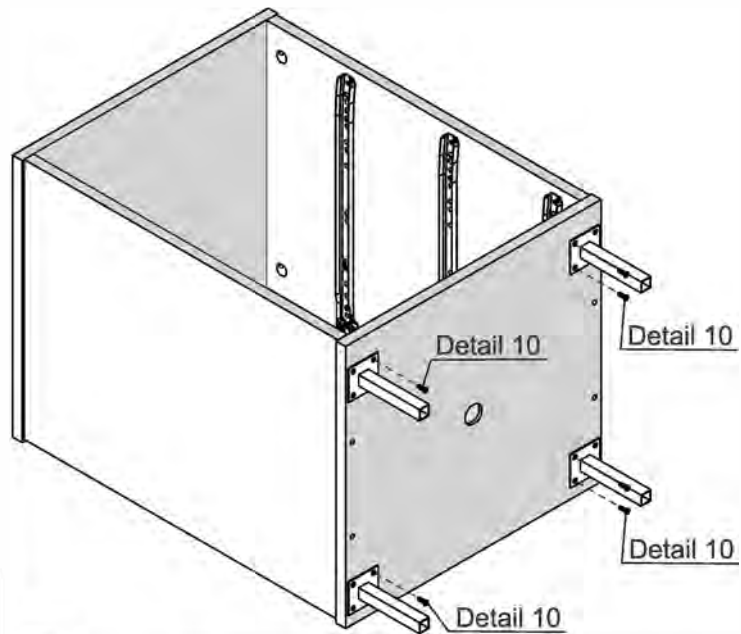

STEP 7

PARTS REQUIRED

5 - BACK PANEL x1

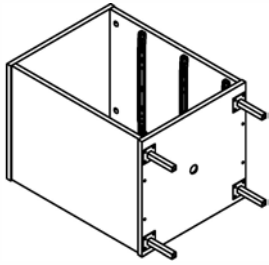

HARDWARE REQUIRED

E  18

TOOLS REQUIRED

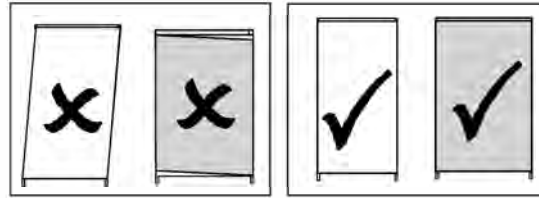
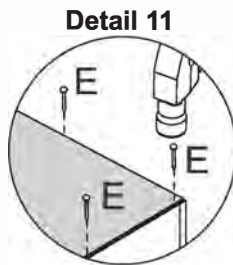
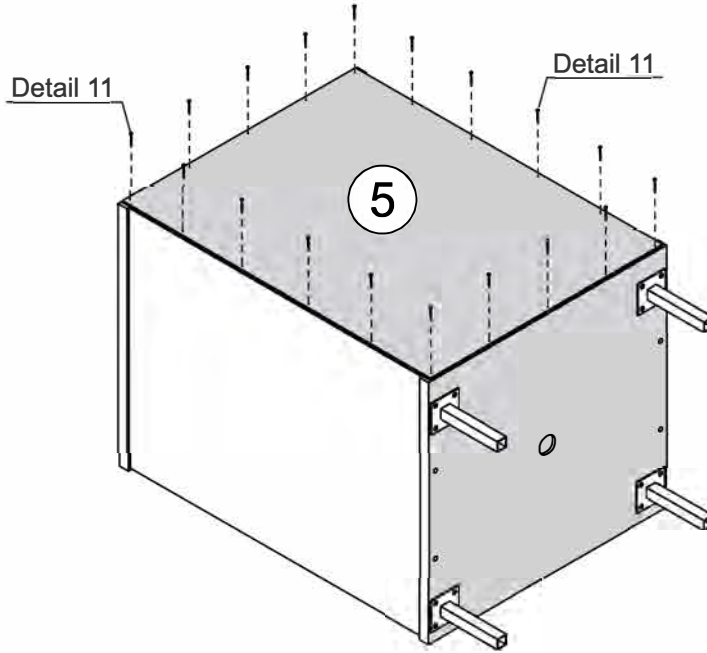
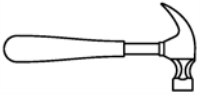

STEP 8

PARTS REQUIRED

6 - DRAWER FRONT x3

7 - DRAWER SIDE PANEL x6

8 - DRAWER BACK PANEL x3

HARDWARE REQUIRED

D  24

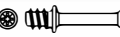
F  06

I  01

TOOLS REQUIRED

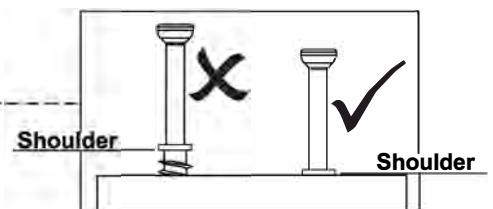
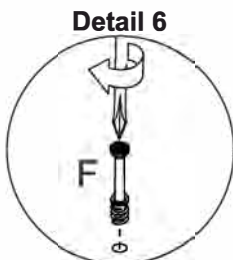
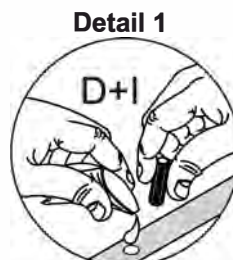
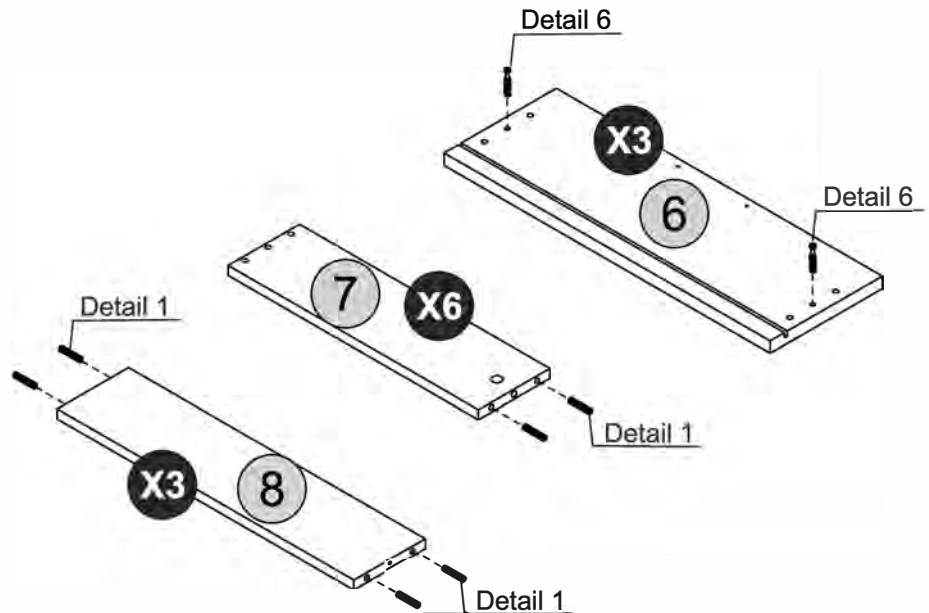
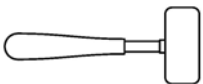
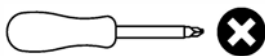

STEP 9

PARTS REQUIRED

7 - DRAWER SIDEL x6

8 - DRAWER BACK PANEL x3

HARDWARE REQUIRED

C  Ø4,0 x 50mm 06

TOOLS REQUIRED

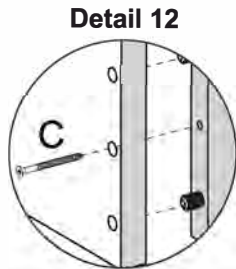
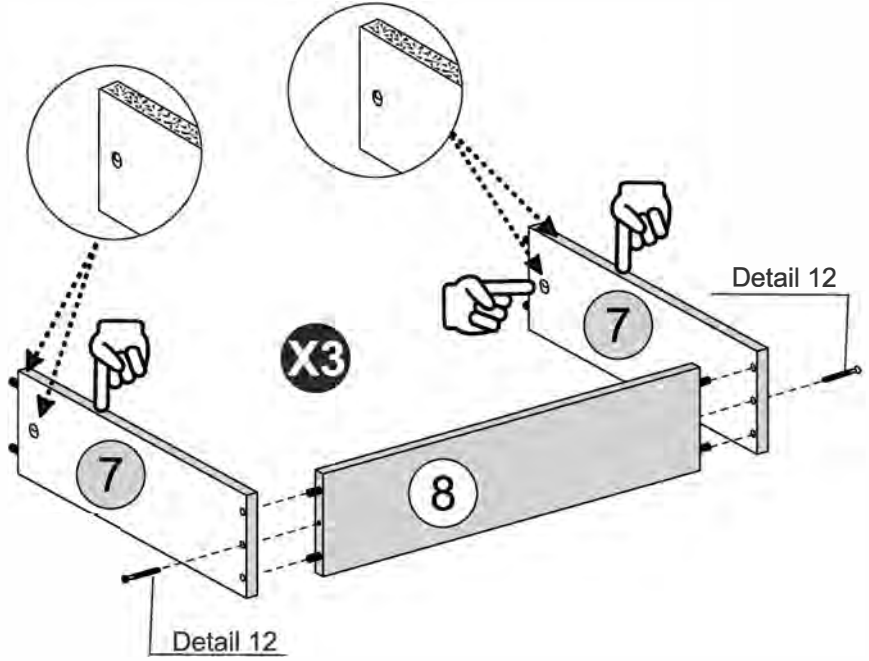

STEP 10

PARTS REQUIRED

6 - DRAWER FRONT x3

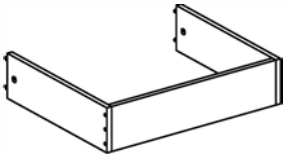

HARDWARE REQUIRED

G  06

I  01

M  06

TOOLS REQUIRED

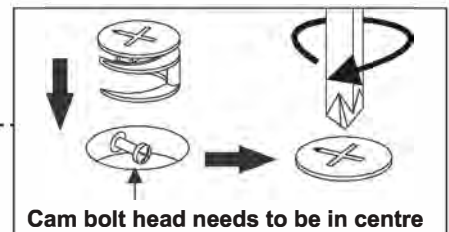
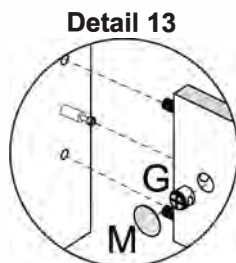
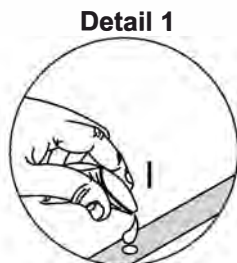
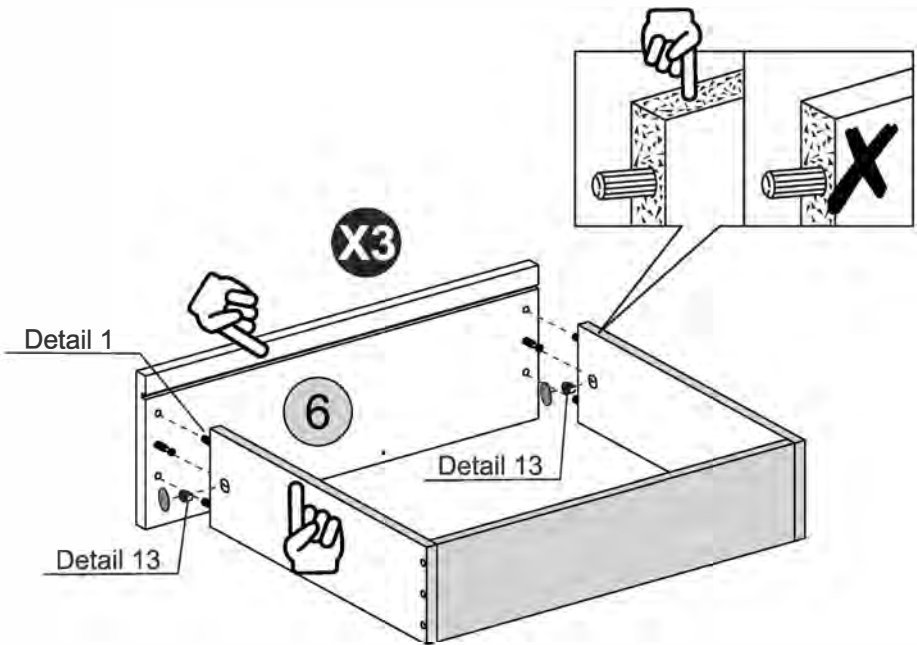
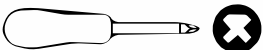

STEP 11

PARTS REQUIRED

9 - DRAWER BOTTOM x3

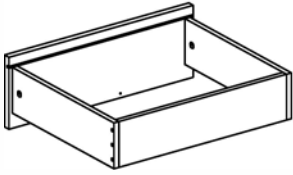

HARDWARE REQUIRED

E  27

TOOLS REQUIRED

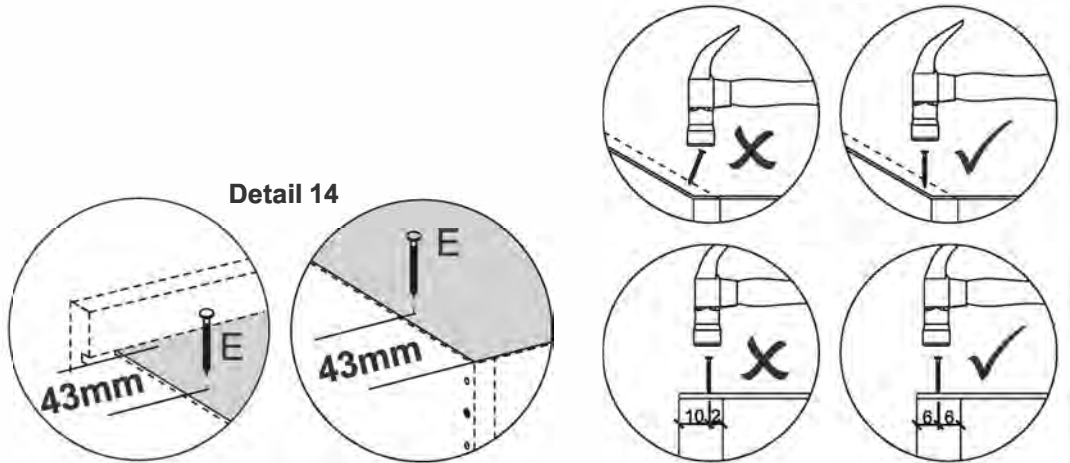
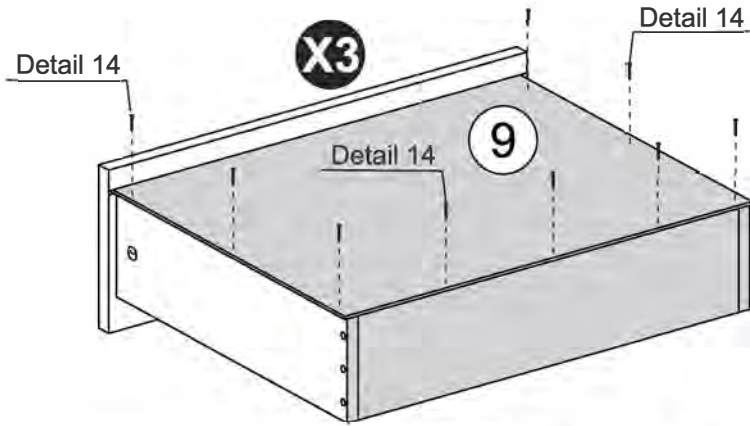
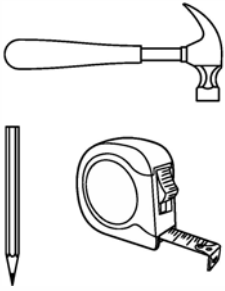

STEP 12

PARTS REQUIRED

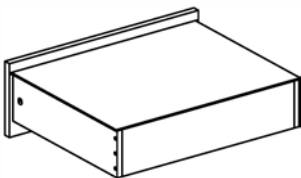

HARDWARE REQUIRED

B  12
Ø4,0 x 14mm

R  LEFT 03

R  RIGHT 03

TOOLS REQUIRED

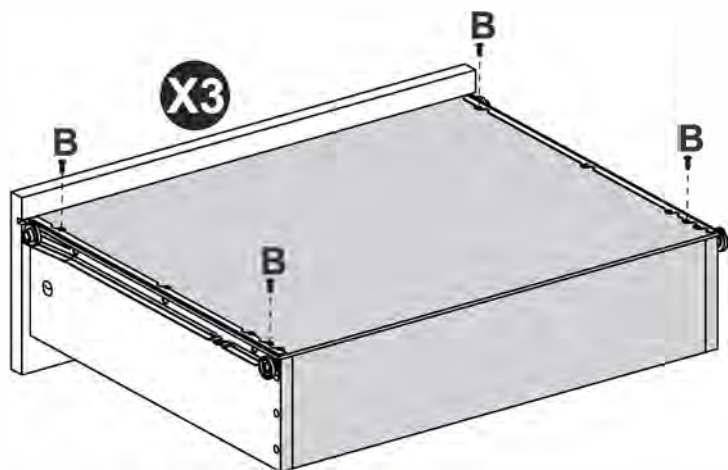

STEP 13

PARTS REQUIRED

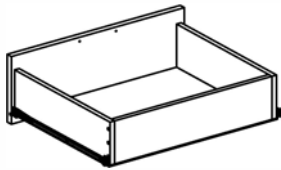

HARDWARE REQUIRED



TOOLS REQUIRED

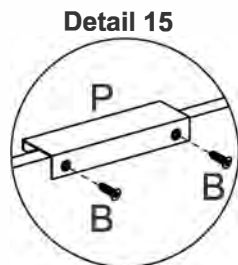
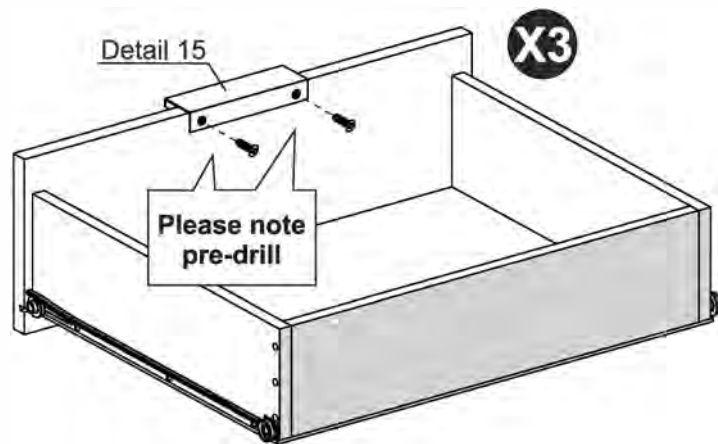

STEP 14

PARTS REQUIRED

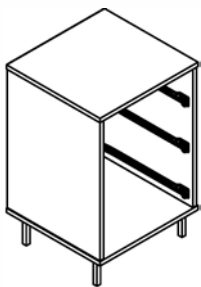

HARDWARE REQUIRED

TOOLS REQUIRED

See the last page

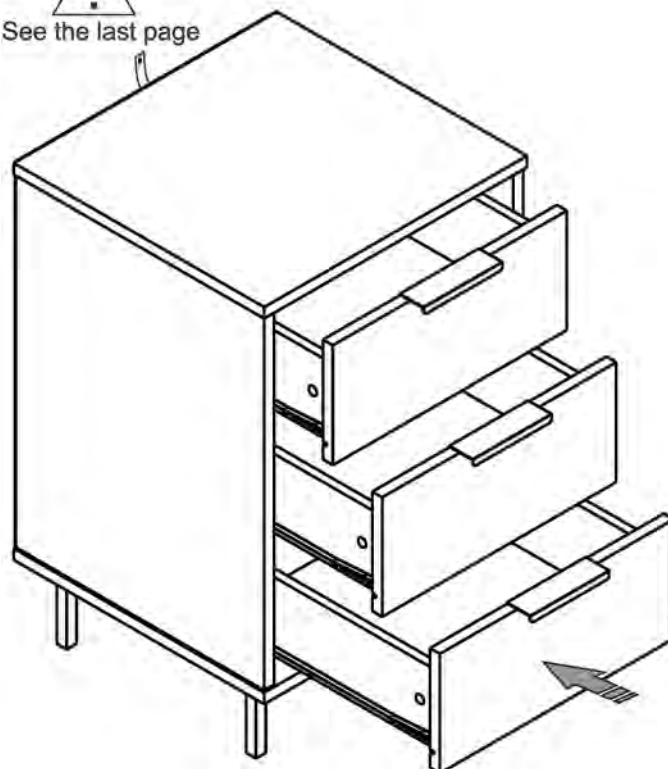

STEP 15

PARTS REQUIRED



HARDWARE REQUIRED



TOOLS REQUIRED

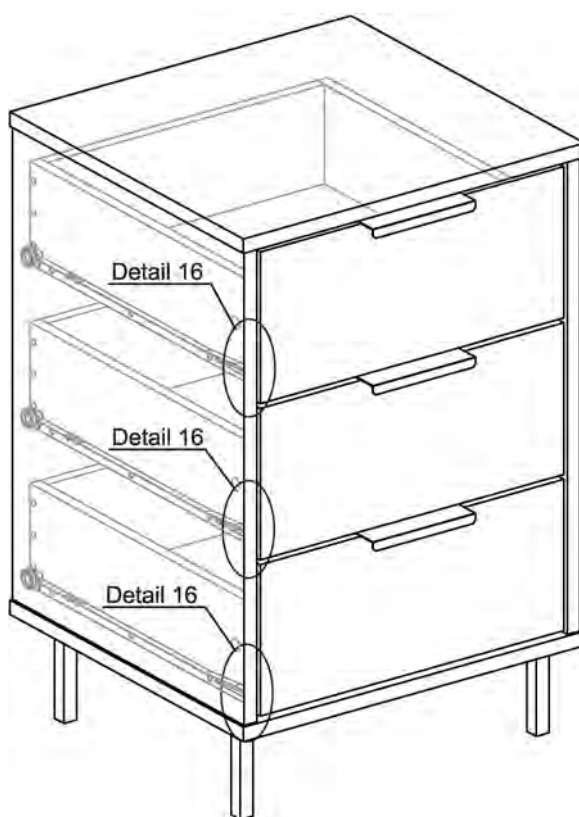

Detail 16
Drawer Lock

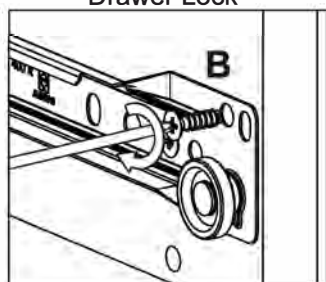

If desired, after assembly use an alcohol cleaner to erase the number printed on the parts.



WARNING

Serious or fatal injuries can occur from furniture tipping over. To prevent the furniture from tipping over we recommend that it is permanently fixed to the wall.

Wall fixings are not supplied with this product as different wall materials require different types of fixing devices. Please make sure you use fixings suitable for the walls in your home.

