

# 50024-011/021/031/041 ASSEMBLY INSTRUCTION

Thank you for purchasing this quality product. Be sure to check all packing material carefully for small parts which may have come loose inside the carton during shipment. Separate, identify and count all parts and hardware. Compare with the parts list to be sure all parts are present.

**IMPORTANT : PLEASE READ INSTRUCTION BEFORE STARTING THE ASSEMBLY.**

**"DO NOT TIGHTEN SCREWS UNTIL COMPLETELY ASSEMBLED"**

**"DO NOT OVERTIGHT ANY HARDWARE"**

**WARNING : SMALL PARTS AND HARDWARE NOT FOR CHILDREN UNDER 3 YEARS. ADULT ASSEMBLY REQUIRED.**

## TABLE OF CONTENTS

HARDWARES LIST	PAGE 2
PARTS LIST	PAGE 3
PARTS' LOCATION	PAGE 4
ASSEMBLY STEPS	PAGE 5 - 6
ASSEMBLY COMPLETED	PAGE 7

## ASSEMBLY TOOLS REQUIRED

### 1. Screwdriver (not provide)

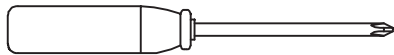

### 2. Hammer (not provide)

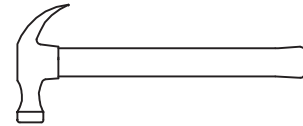



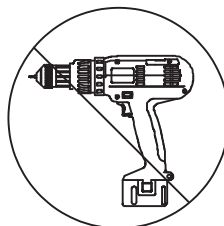



Skip the power trip this time.



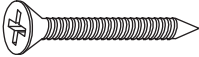

# 50024-011/021/031/041 ASSEMBLY INSTRUCTION

## HARDWARES LIST

ITEM	DESCRIPTION	DRAWING	QTY
A	JCBB SCREW M8 x 20MM		8 PCS
B	JCBC SCREW M6 x 15MM		12 PCS
C	JCBC SCREW M6 x 50MM		4 PCS
D	SPRING WASHER M6 x 13MM		4 PCS
E	FLAT WASHER M6 x 19MM		4 PCS
F	CSK C/B SCREW (M4 x 32MM)		8 PCS
G	M4 ALLEN KEY (100MM)		1 PC
H	M5 ALLEN KEY (65MM)		1 PC

# 50024-011/021/031/041 ASSEMBLY INSTRUCTION

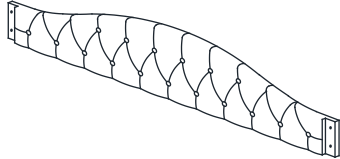
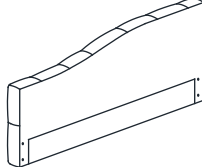
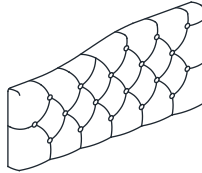
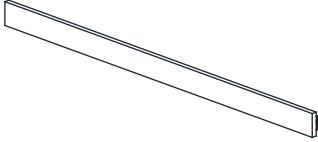
## PARTS LIST

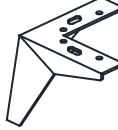
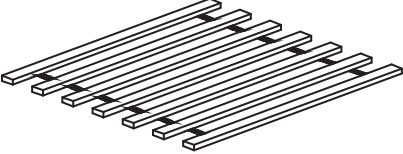
ITEM	DESCRIPTION	DRAWING	QTY
1	BACK REST		1 PC
2	SIDE PANEL (L)		1 PC
3	SIDE PANEL (R)		1 PC
4	FRONT SIDE RAIL		1 PC
5	BACK SIDE RAIL		1 PC
6	LEG		4 PCS
7	DAYBED SLAT		2 ROLL

# 50024-011/021/031/041 ASSEMBLY INSTRUCTION

## PARTS ' LOCATION

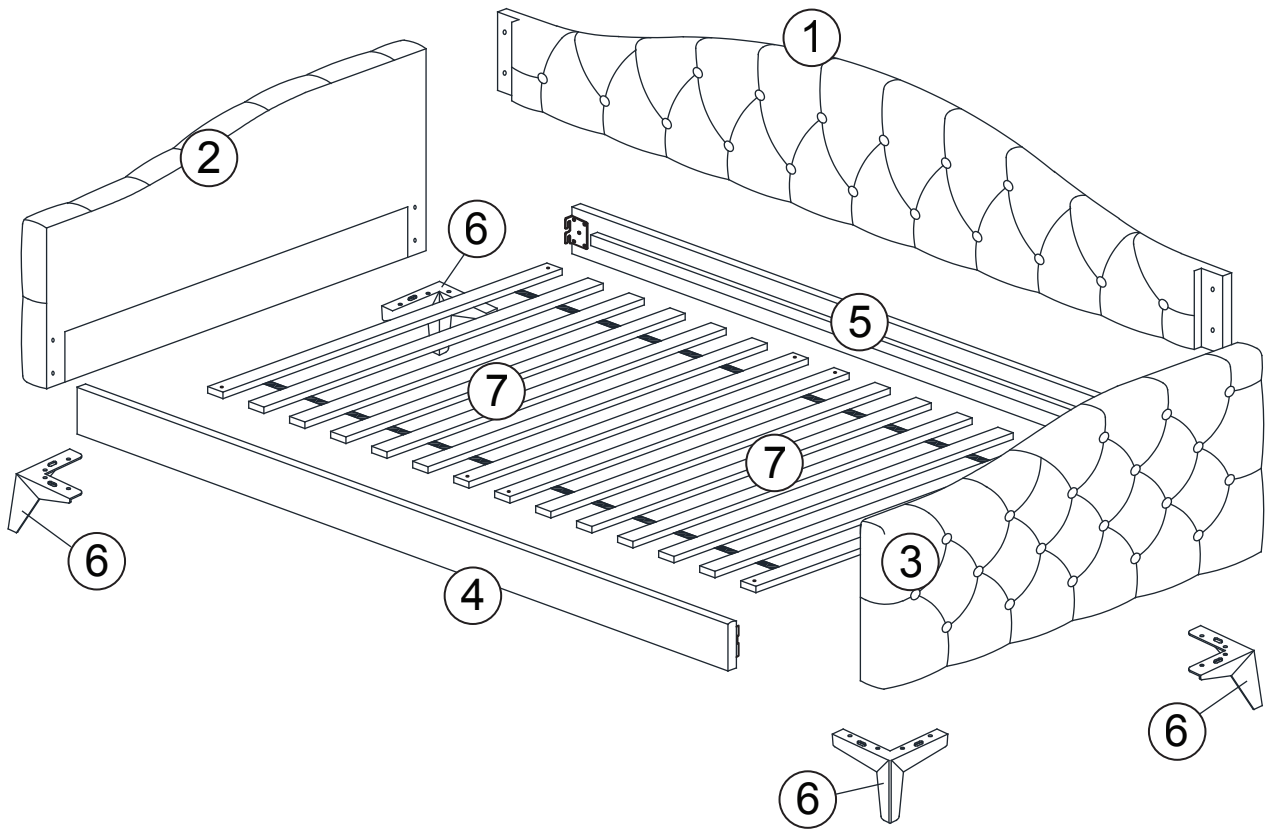

# 50024-011/021/031/041 ASSEMBLY INSTRUCTION

## STEP 1

Insert 12pcs (B) to combine 4pcs (6) to (2) and (3) as shown.

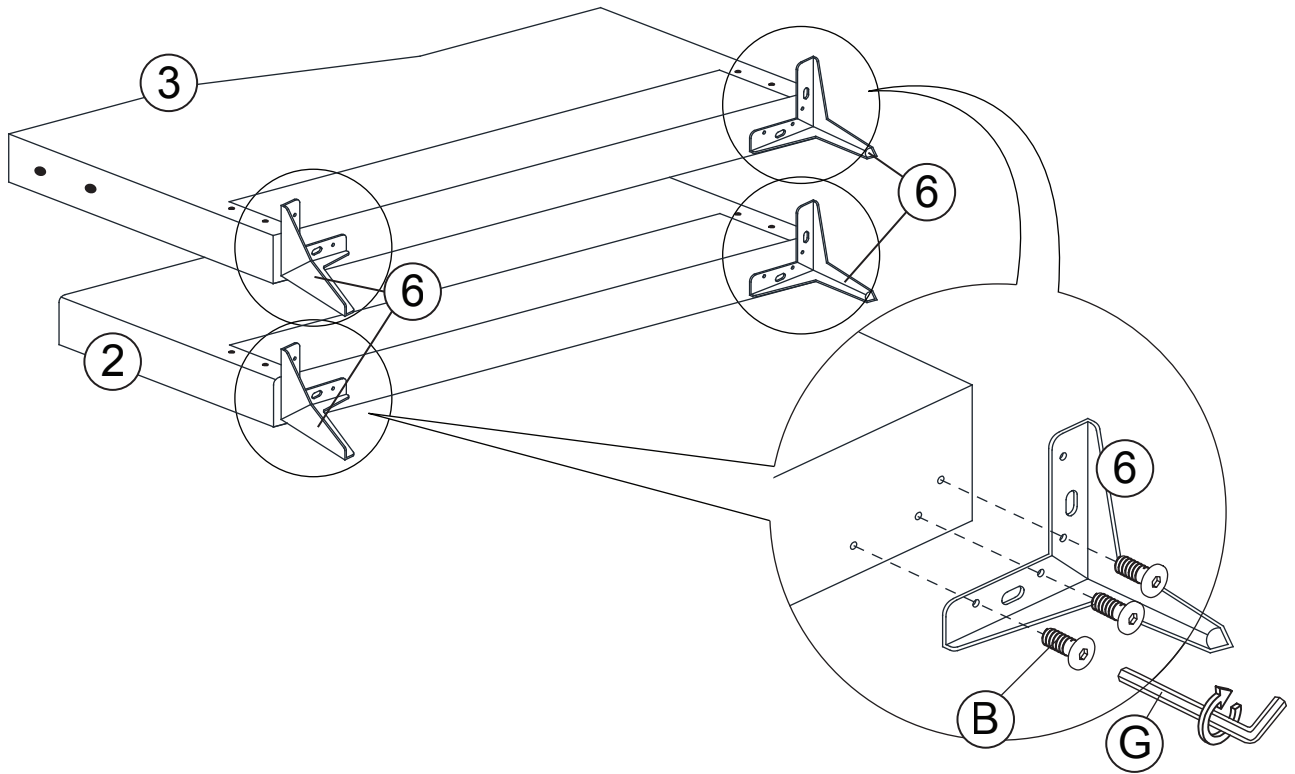

## STEP 2

Insert 8pcs (A) to combine (4) and (5) to (2) and (3) as shown.

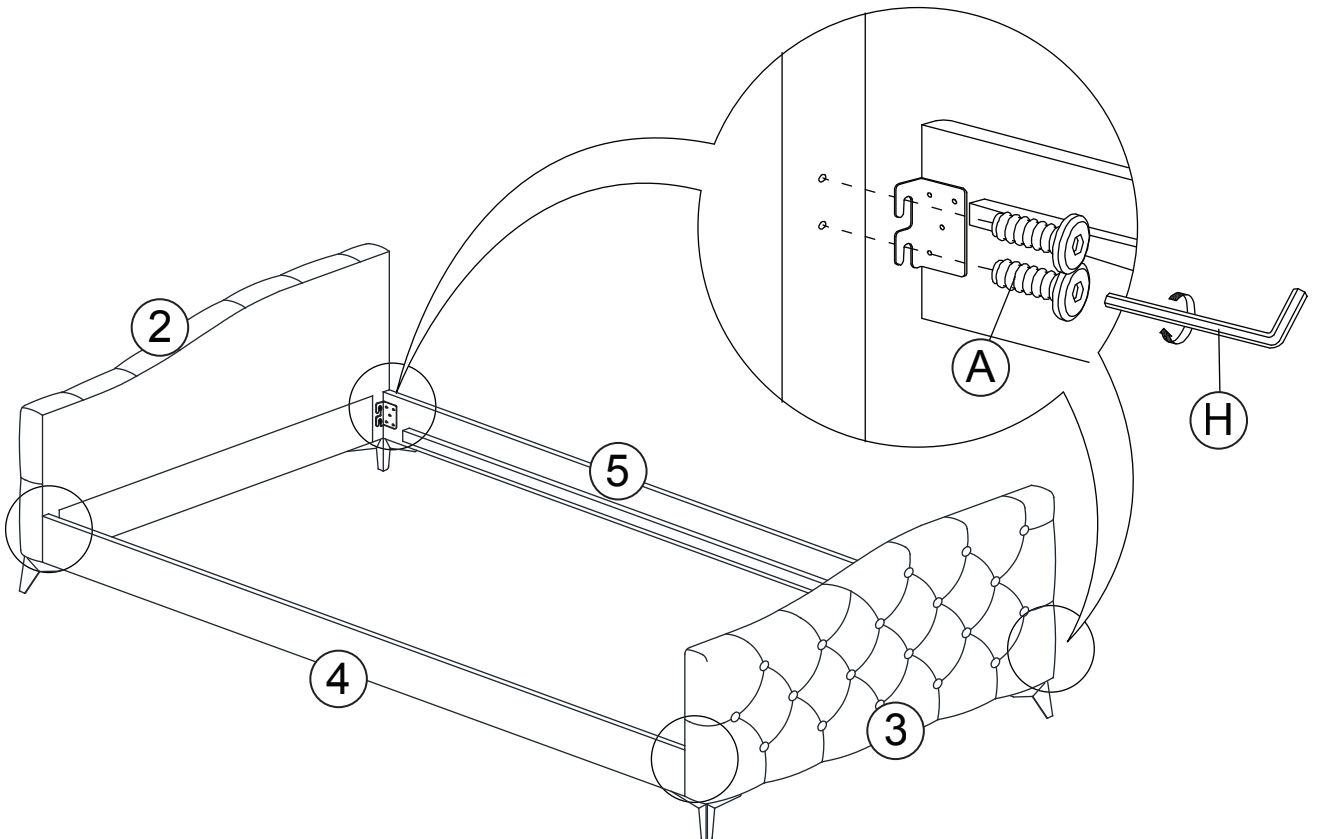

# 50024-011/021/031/041 ASSEMBLY INSTRUCTION

## STEP 3

Insert 4pcs (C) , (D) and (E) to combine (1) to (2) and (3) as shown.

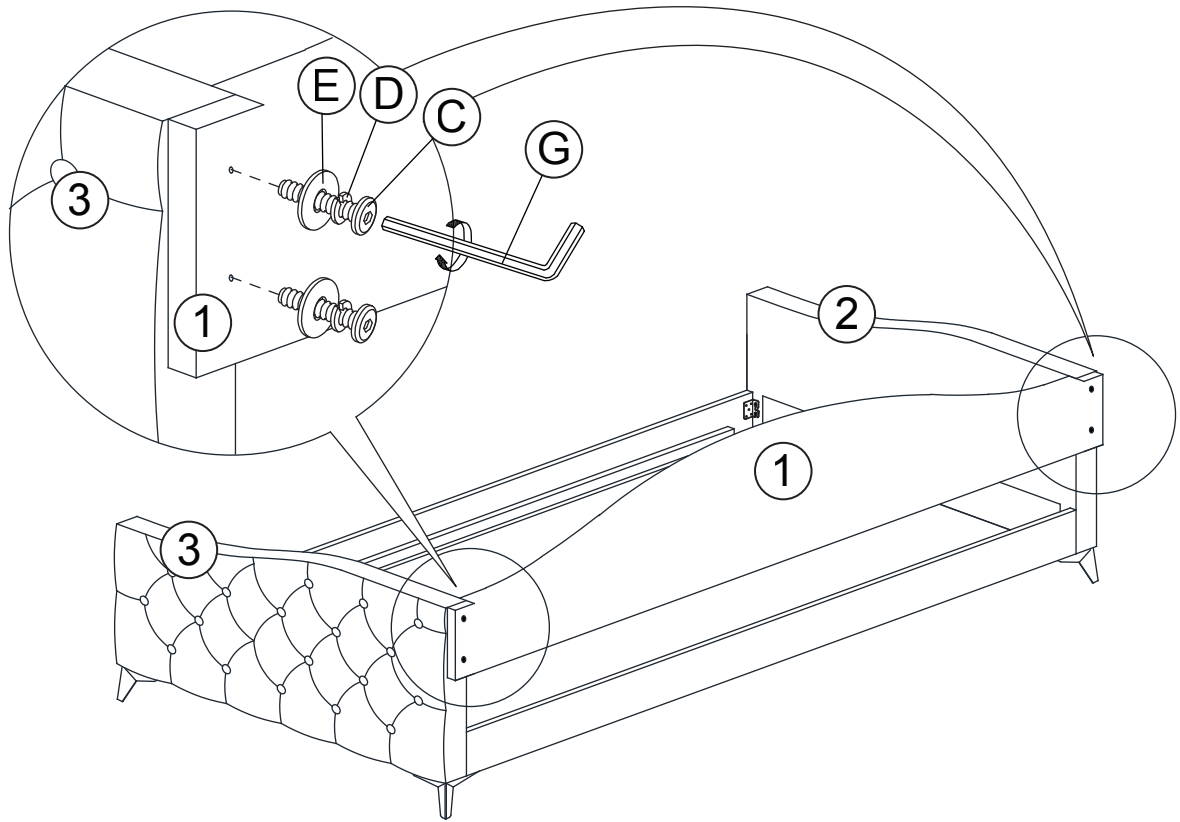

## STEP 4

Put the slat to the inside of daybed , then insert 8pcs (F) to tighten the slat.

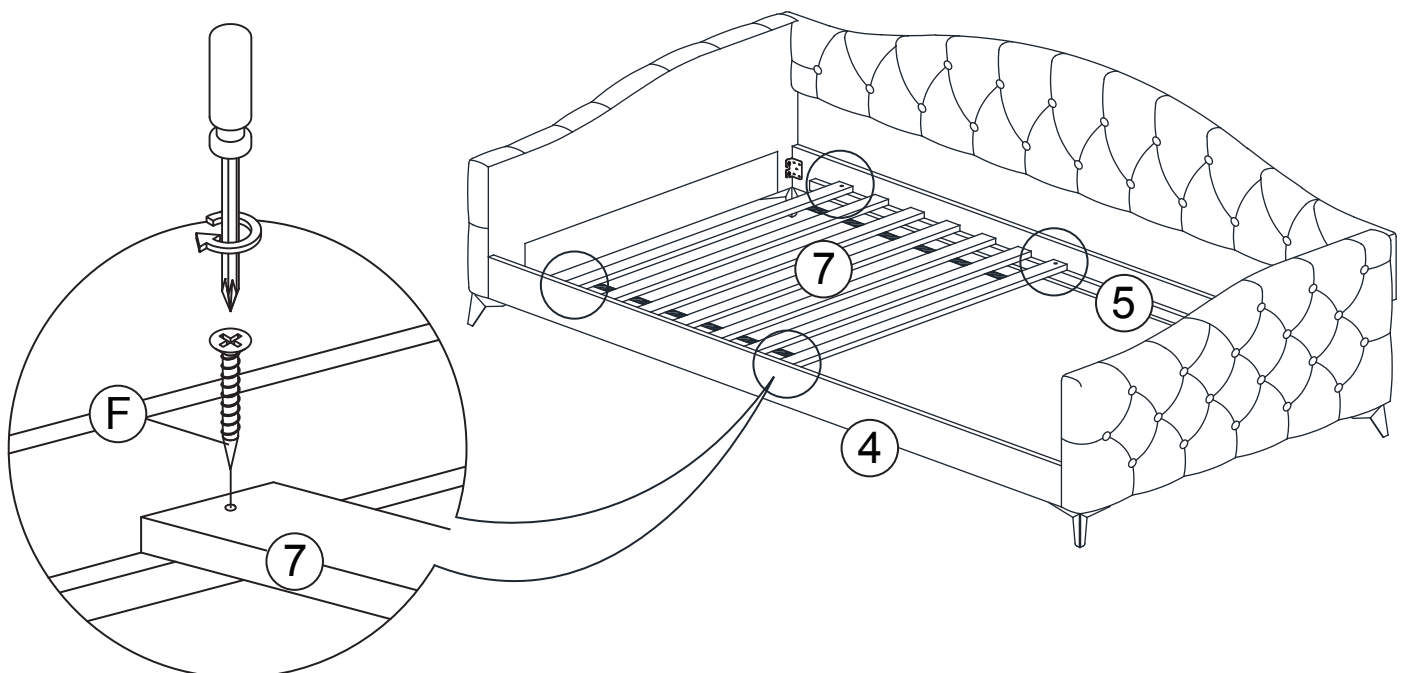

# 50024-011/021/031/041 ASSEMBLY INSTRUCTION

## STEP 5

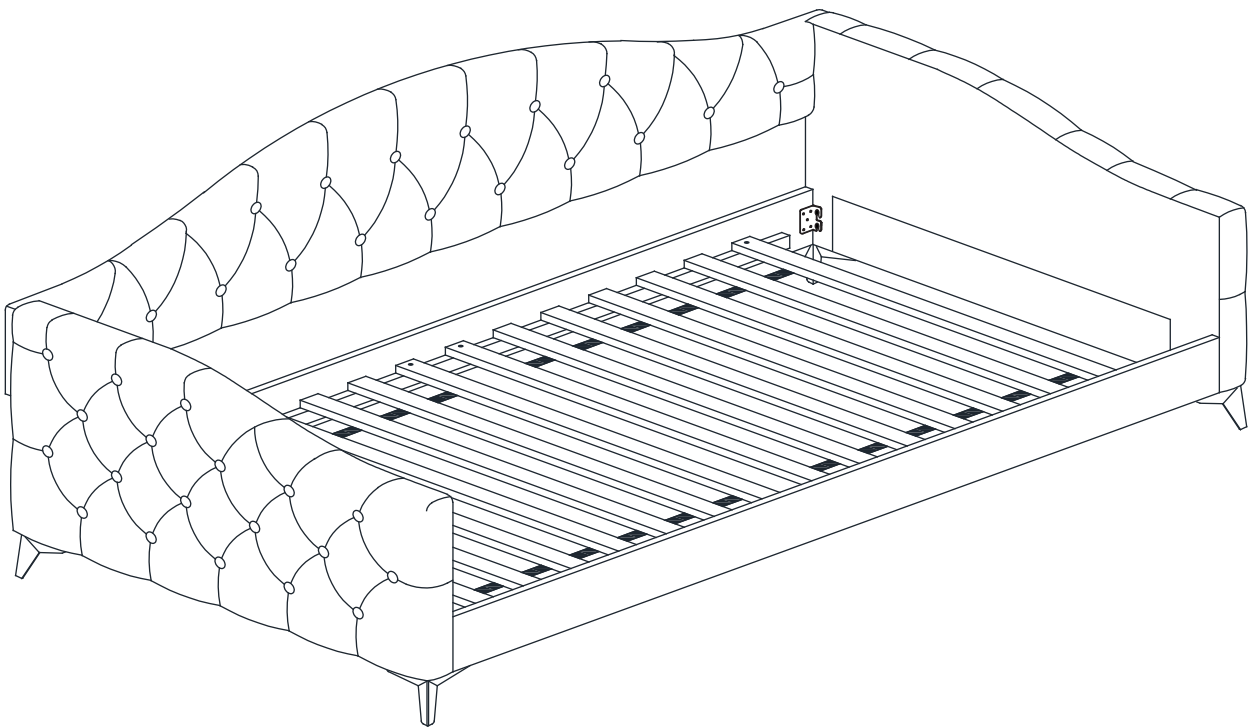

**ASSEMBLY COMPLETED**