

Installation Manual Manual de Instalación

For technical support contact
Para soporte técnico, póngase en contacto con
626-341-5763
grace@homebandc.com
<http://www.homebandc.com/>

TaiMei

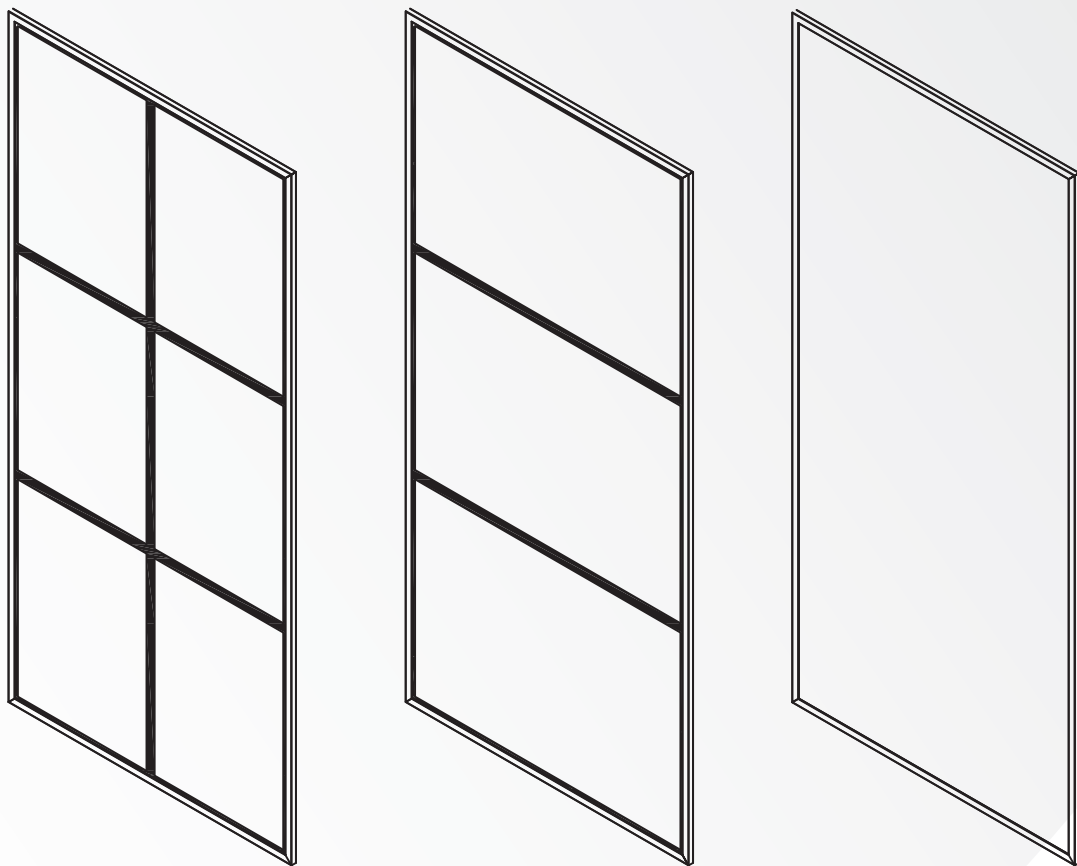

SHOWER
SCREEN

34 in. W × 72 in. H

PANTALLA DE
DUCHA

34 pulgadas de ancho × 72 pulgadas de alto

Model Number/Número de modelo: 1010 Series

TABLE OF CONTENTS

01 English

Component Details	1
Pre-Installation Guidelines	2
Installation Steps	3-4

02 Español

Detalles del componente	5
Instrucciones previas a la instalación	6
Pasos de instalación	7-8

Detailed Diagram of Shower Door Components

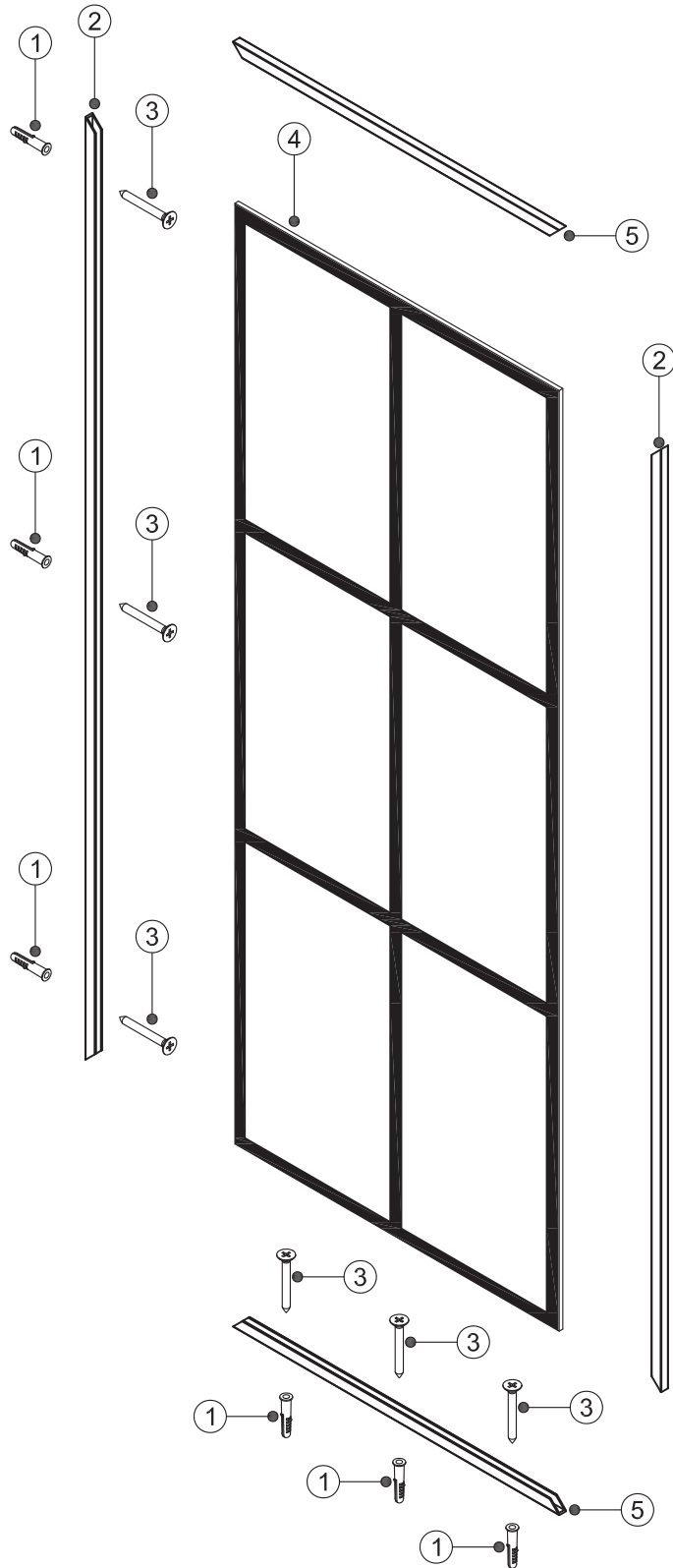

PARTS LIST.

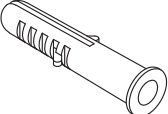
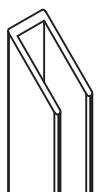
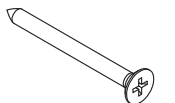
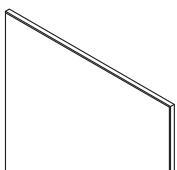
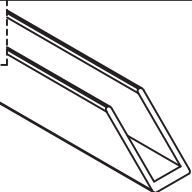
				
WALL PLUG (6 PCS)	WALL JAMB (2 PCS)	SCREW 1 3/8" (6 pcs)	GLASS PANEL (1 pcs)	U-CHANNEL (2 pcs)

Before You Start



Thank you for choosing our sliding shower door. We aim to provide you with the most satisfying product and user experience. Please carefully read through this manual as it contains important product information and step-by-step installation instructions. Failure to follow the instructions may affect the product's warranty.

- 1.** Before installation, please inspect the boxes for any damage caused during shipping. If any parts are missing or defective, please contact our customer service by email at info@lifeupinc.net within 7 business days from the delivery date. Please note that we will not provide free replacements for damaged products or missing parts if you contact us more than 7 business days after product installation. Feel free to reach out if you have any questions related to your purchase order number.
- 2.** Ensure that you consult your local building codes if you have any questions about installation standards. Building and plumbing codes may vary depending on your location.
- 3.** Verify that the installation surface or level is strong enough to support the weight of the shower door. Do not install it on plastic shower modules or drywall unless additional support is provided behind the wall.
- 4.** This shower door is quite heavy and should be installed by a professional.

⚠ Warnings

- 1.** Always wear safety glasses when cutting or drilling.
- 2.** Unframed tempered glass should never come into contact with rigid surfaces, as it may shatter. Avoid touching the edge of the tempered glass panel with tools or any rigid object, and refrain from placing the unframed tempered glass edge directly on the floor.
- 3.** Do not try to cut tempered glass, as it will shatter.

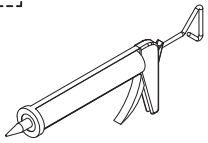
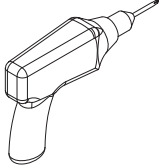
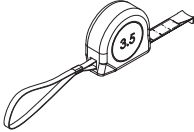
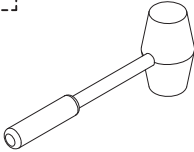
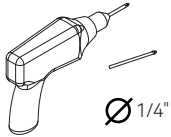
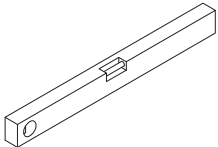
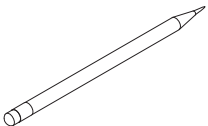
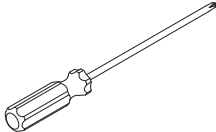
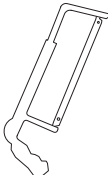
Required Tools

				
SILICONE	DRILL	MEASURE TAPE	RUBBER MALLET	DRILL BITS
				
LEVEL	PENCIL	SCREW DRIVERS	HANDSAW	SAFETY GLASSES

▪ STEP 1

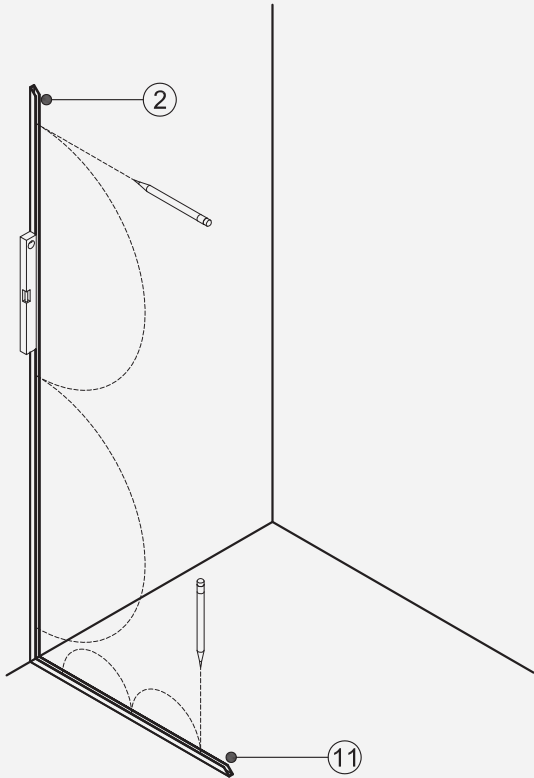

▪ STEP 2

For drywall thicker than 10-12mm, please ensure the use of specified drywall anchors for installation. For drywall with a thickness less than 10-12mm, please make sure to install the brackets on the stud.

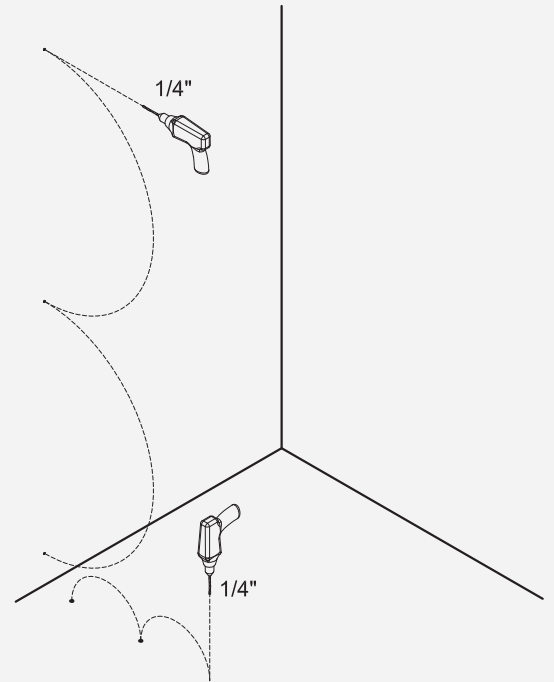

▪ STEP 3

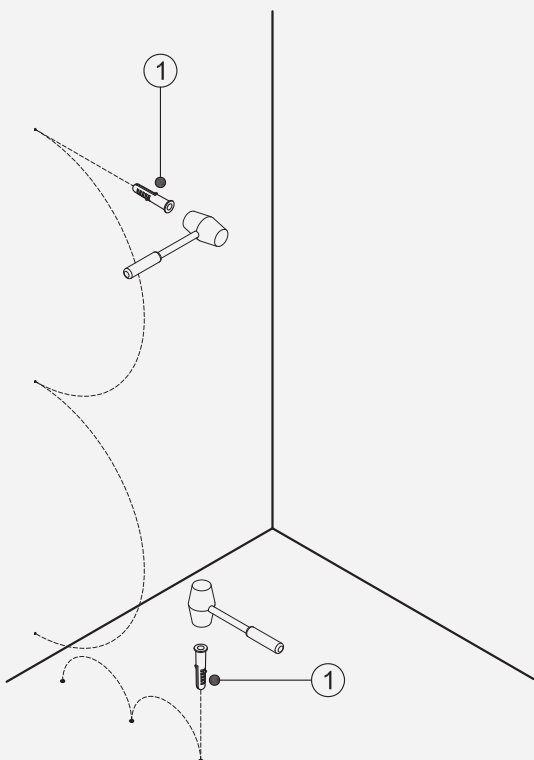

▪ STEP 4

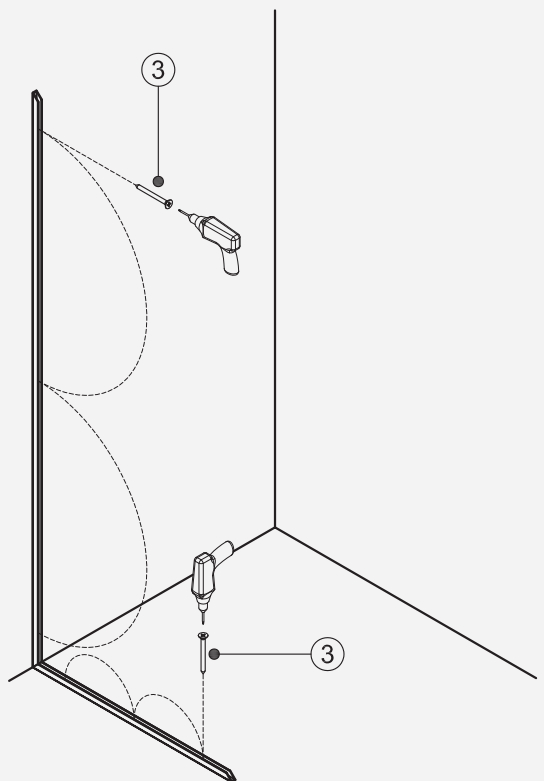

▪ STEP 5

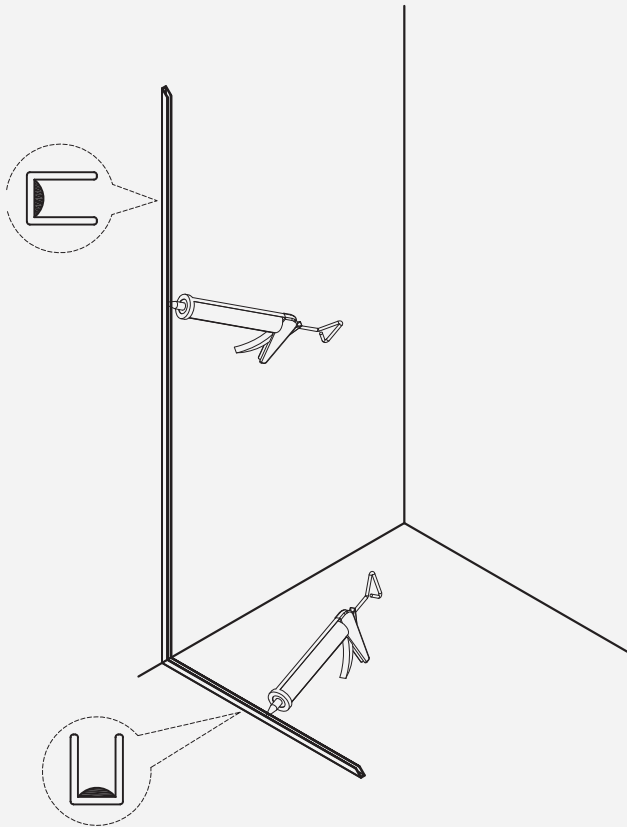

▪ STEP 6

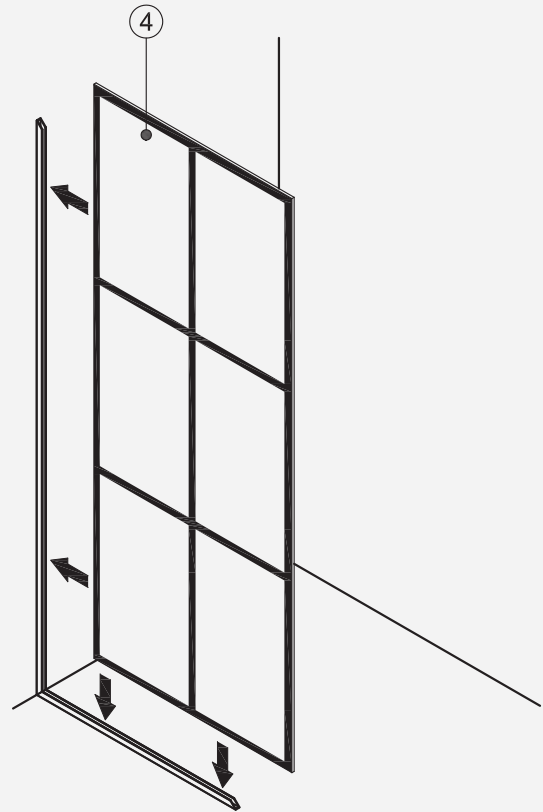

▪ STEP 7

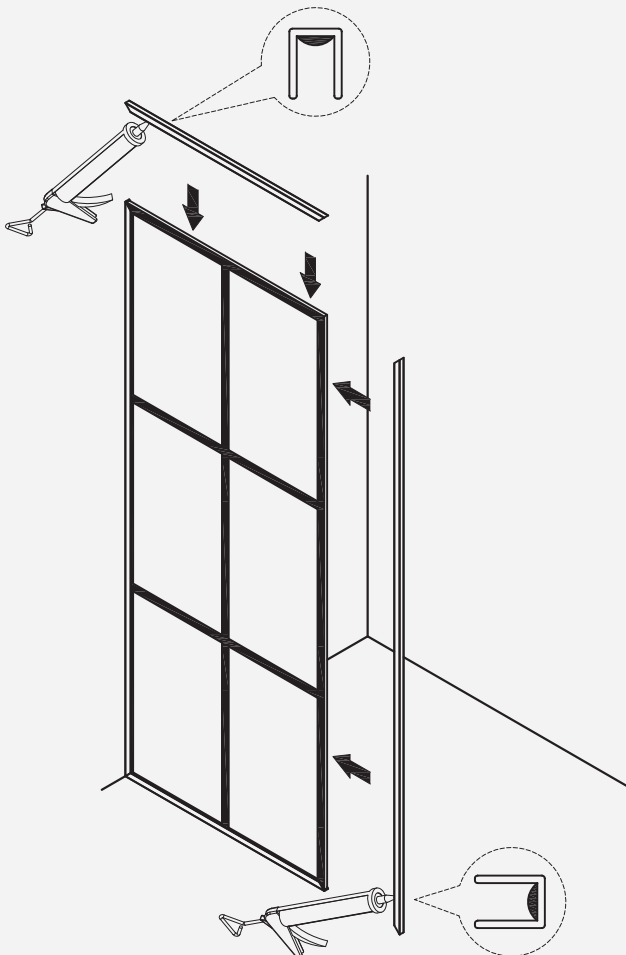

▪ STEP 8

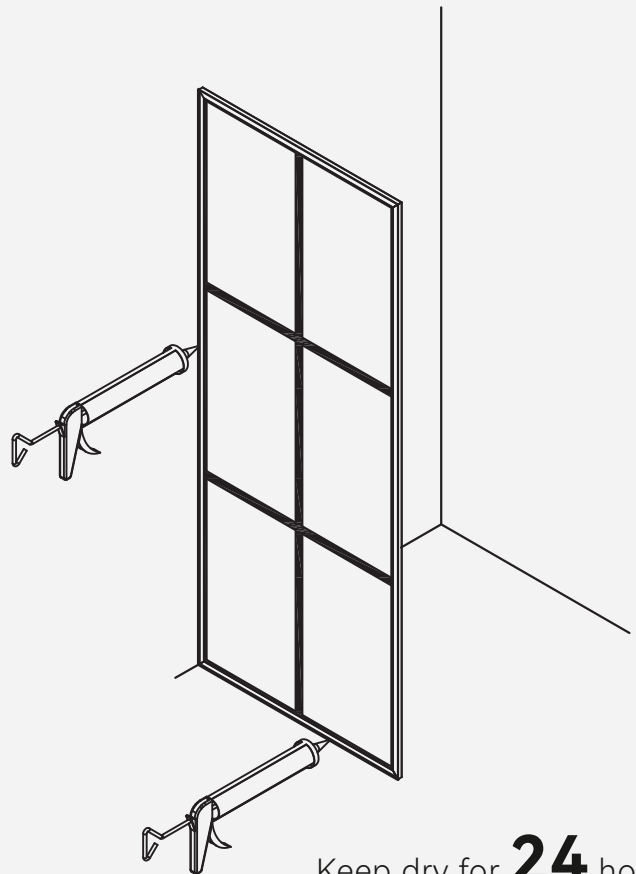

Keep dry for **24** hours.

Diagrama Detallado de los Componentes de la Puerta de la Ducha

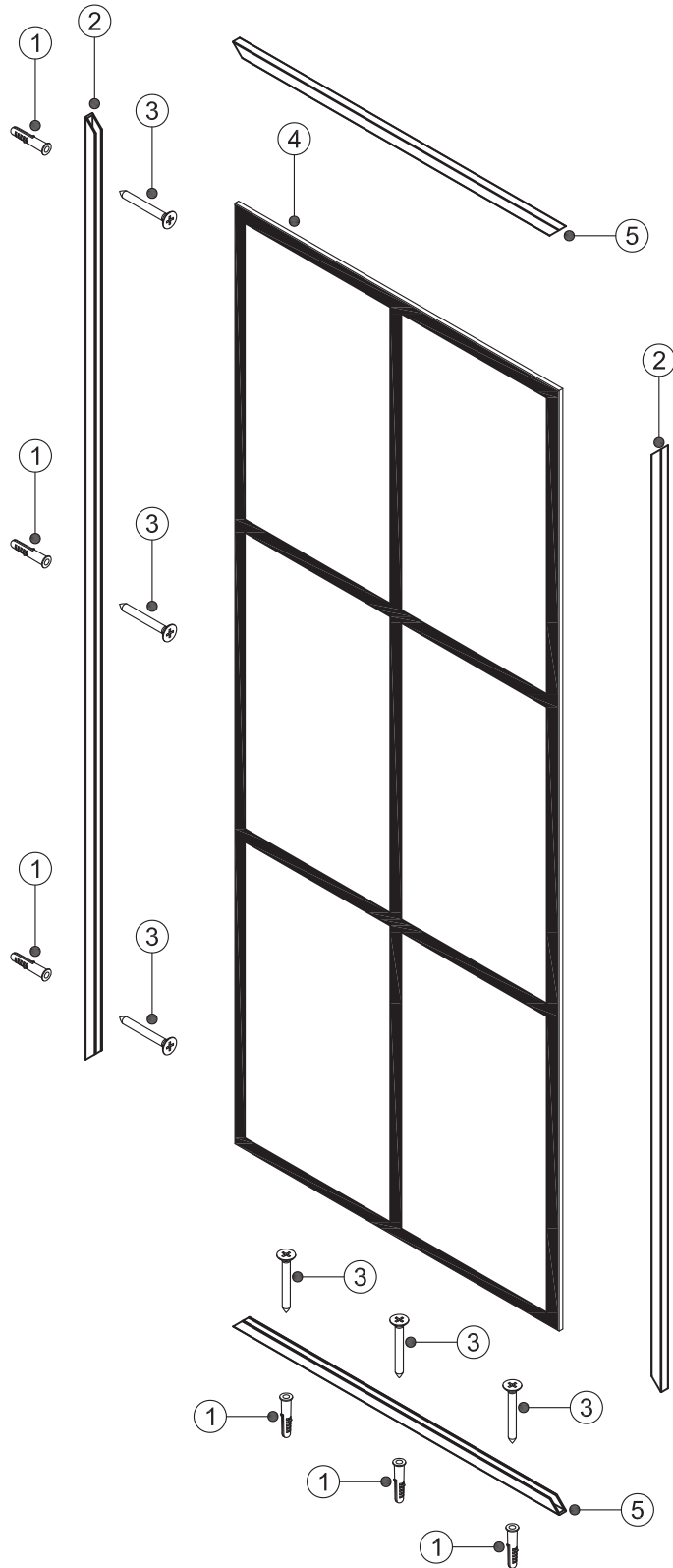

LISTA DE PIEZAS.

ENCHUFE DE PARED (6 pieza)	JAMBA DE PARED (2 piezas)	TORNILLO 1 3/8" (6 piezas)	PANEL DE VIDRIO (1 pieza)	U-CANAL (2 piezas)

Antes de comenzar



Gracias por elegir nuestra puerta de ducha corrediza. Nuestro objetivo es brindarle el producto más satisfactorio y una experiencia de usuario óptima. Lea detenidamente este manual, ya que contiene información importante del producto e instrucciones de instalación paso a paso. No seguir las instrucciones puede afectar la garantía del producto.

- 1.** Antes de la instalación, por favor inspeccione las cajas en busca de cualquier daño causado durante el envío. Si falta alguna pieza o hay piezas defectuosas, por favor contacte a nuestro servicio de atención al cliente por correo electrónico a info@lifeupinc.net dentro de los 7 días hábiles a partir de la fecha de entrega. Tenga en cuenta que no proporcionaremos reemplazos gratuitos para productos dañados o piezas faltantes si nos contacta más de 7 días hábiles después de la instalación del producto. No dude en ponerse en contacto si tiene alguna pregunta relacionada con el número de pedido de su compra.
- 2.** Asegúrese de consultar los códigos de construcción locales si tiene alguna pregunta sobre las normas de instalación. Los códigos de construcción y plomería pueden variar según su ubicación.
- 3.** Verifique que la superficie de instalación esté lo suficientemente fuerte como para soportar el peso de la puerta de ducha. No la instale en módulos de ducha de plástico o en paneles de yeso a menos que se proporcione soporte adicional detrás de la pared.
- 4.** Esta puerta de ducha es bastante pesada y debe ser instalada por un profesional.

⚠ Advertencias

- 1.** Siempre use gafas de seguridad al cortar o perforar.
- 2.** El vidrio templado sin marco nunca debe entrar en contacto con superficies rígidas, ya que puede romperse. Evite tocar el borde del panel de vidrio templado sin marco con herramientas u objetos rígidos, y absténgase de colocar el borde del vidrio templado sin marco directamente en el suelo.
- 3.** No intente cortar el vidrio templado, ya que se romperá.

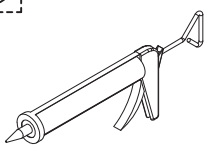
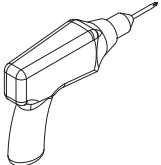
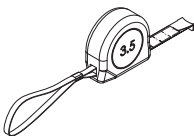
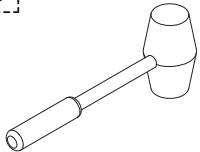
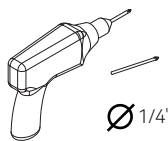
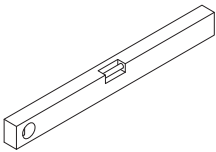
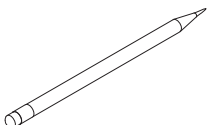
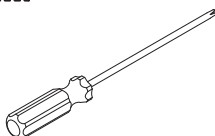
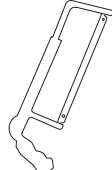
Outils nécessaires

				
SILICONA	PERFORADORA	CINTA MÉTRICA	MARTILLO DE GOMA	PUNTAS DE TALADRO
				
NIVEL	LÁPIZ	DESTORNILLADORES	SIERRA DE MANO	GAFAS DE SEGURIDAD

▪ PASO 1

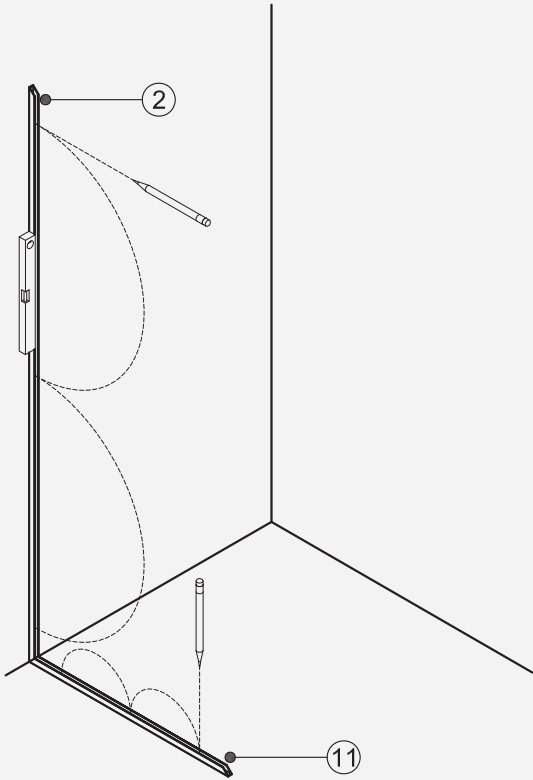

▪ PASO 2

Para paneles de yeso con un grosor superior a 10-12 mm, asegúrese de usar los anclajes específicos para paneles de yeso para la instalación. Para paneles de yeso con un grosor inferior a 10-12 mm, asegúrese de instalar los soportes en el montante.

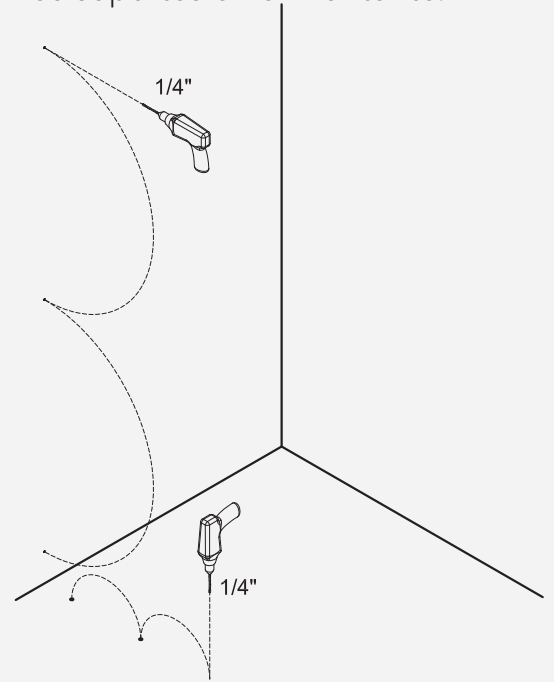

▪ PASO 3

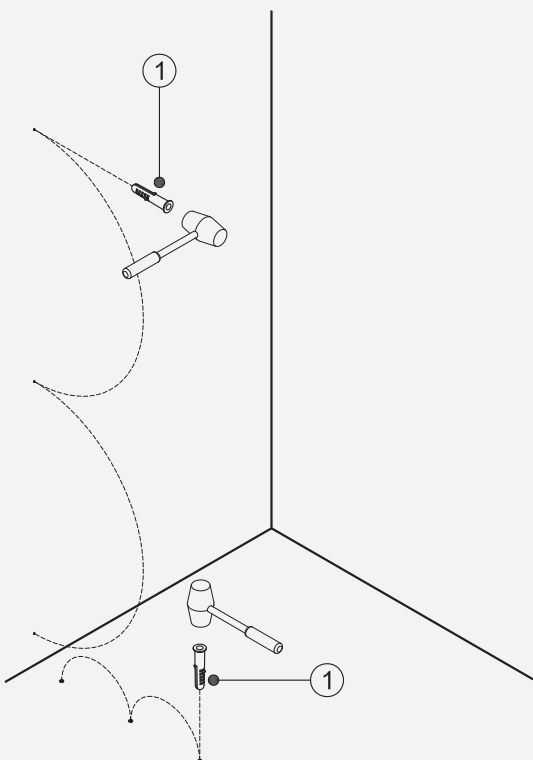

▪ PASO 4

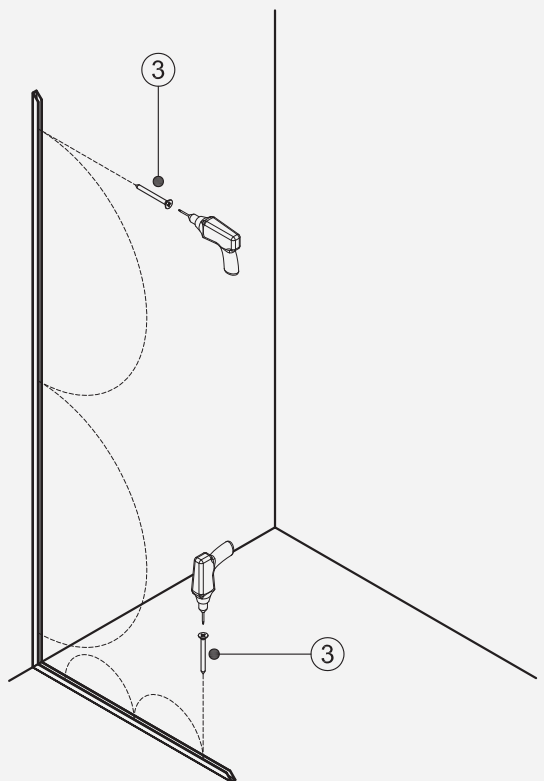

▪ PASO 5

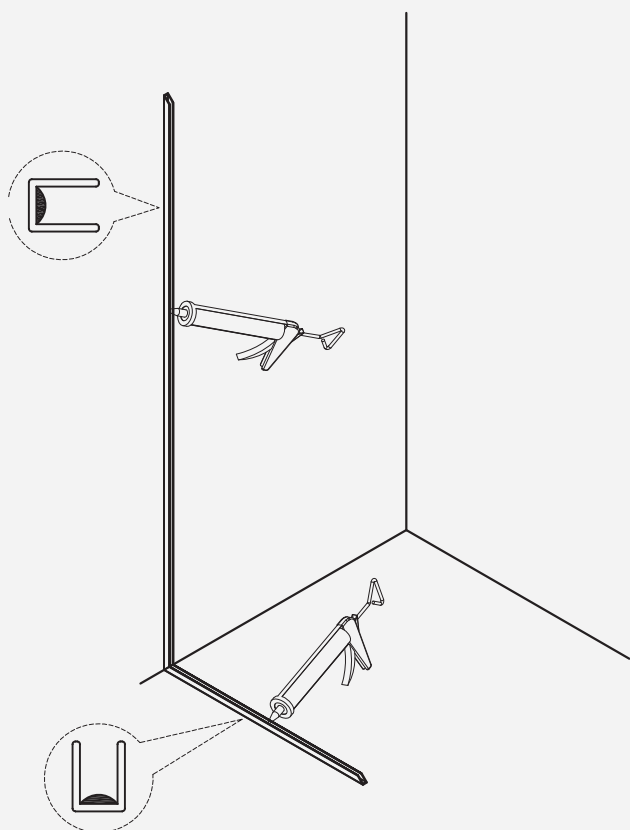

▪ PASO 6

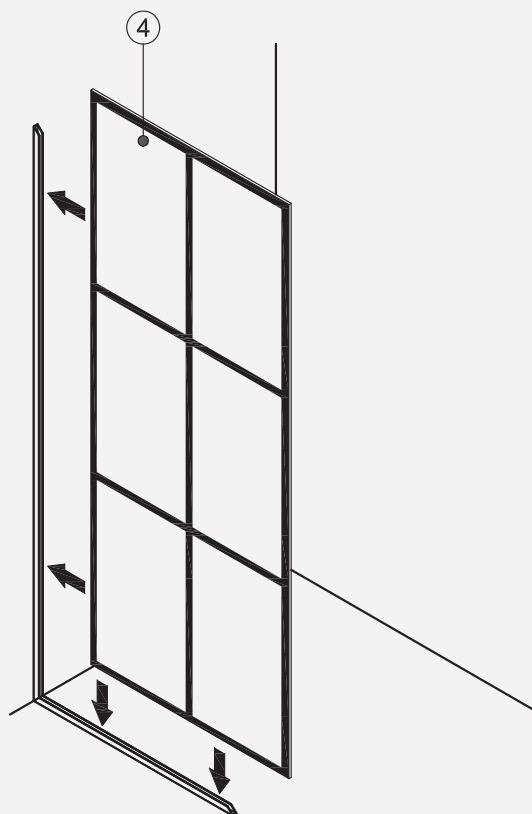

▪ PASO 7

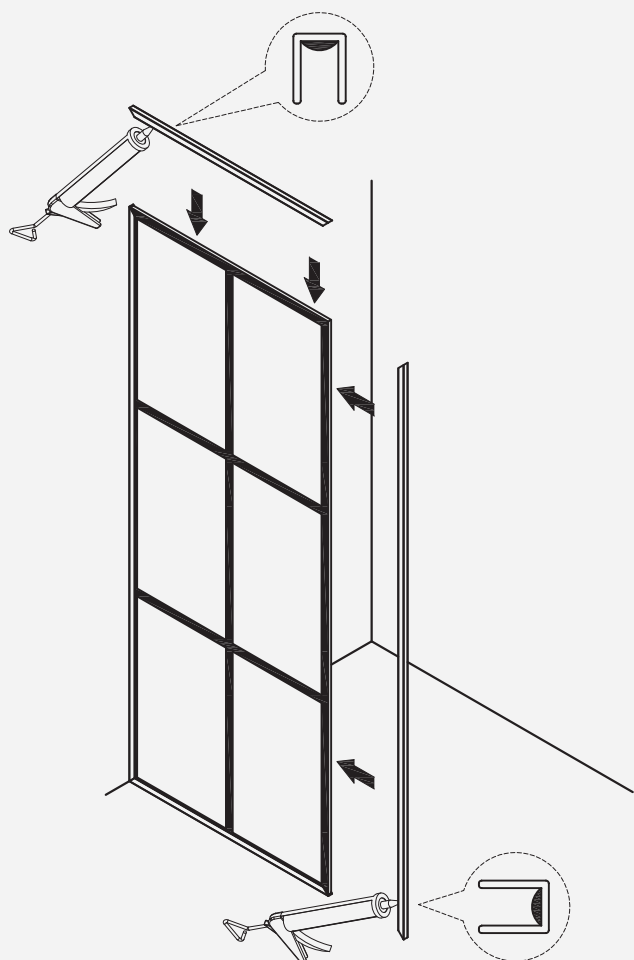

▪ PASO 8

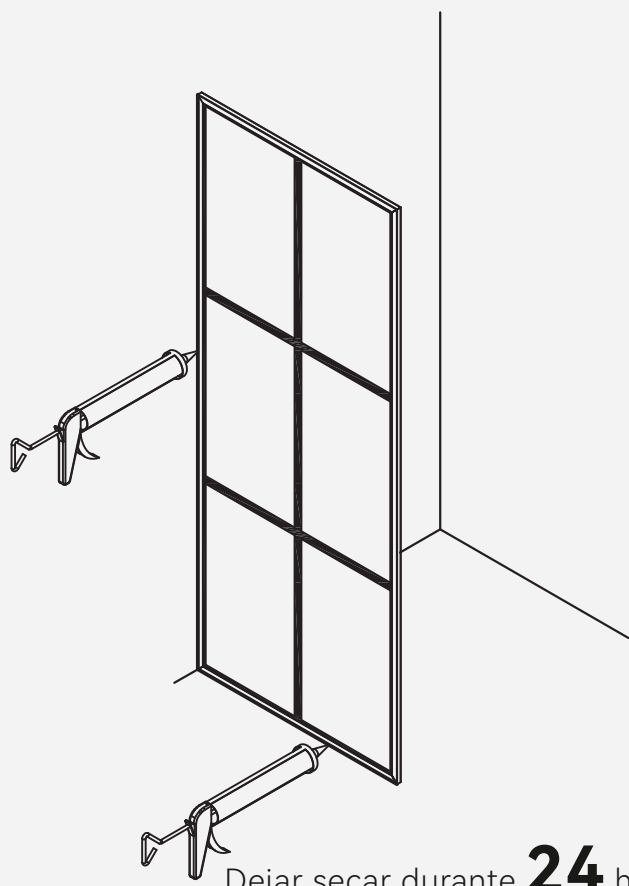

Dejar secar durante **24** horas.