







# ASSEMBLY INSTRUCTION

## ITEM :



### (BOX 1) B9260-K-HB

NO	PARTLIST	QTY
A	 HEADBOARD PANEL	1PC









### (BOX 2) B9260-K-FBRL

B	 BED SLAT	4PCS
C	 FOOTBOARD PANEL	1PC
D	 FOOTBOARD LEG	2PCS
E	 BED SLAT SUPPORT WITH LEVELER	8PCS
F	 LEFT BED RAIL	1PC
G	 RIGHT BED RAIL	1PC

### (BOX 3) B9260-KQ-WG

H	 LEFT WING	1PC
I	 RIGHT WING	1PC

### (BOX 2) B9260-K-FBRL

NO	HARDWARE	QTY
1	 JCBB SCREW M8 x 20mm	4PCS
2	 JCBC SCREW M6 x 16mm	6PCS
3	 JCBC SCREW M6 x 35mm	8PCS
4	 JCBC SCREW + WASHER M6 x 35mm	6PCS
5	 JCBB SCREW + WASHER M8 x 60mm	4PCS
6	 WOOD DOWEL M10 x 30mm	4PCS
7	 CHIPBOARD SCREW M4 x 32mm	8PCS
8	 L - KEY M4 x 100mm	1PC
9	 L - KEY M5 x 65mm	1PC

NOTE : THE HARDWARE PACK IN BOX 2

## STEP 1

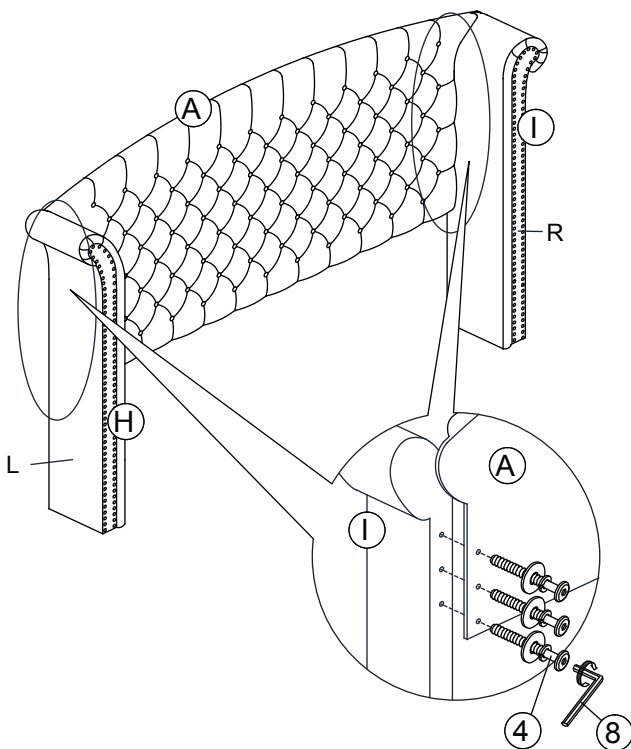

## STEP 2

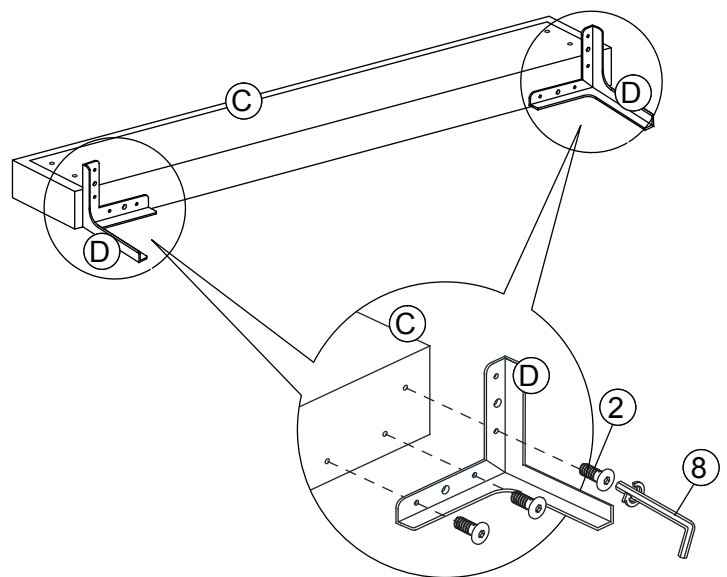

THE HARDWARE ID LOCATED IN THE PACKING ITEMS

NOTE : MUST TIGHT SCREWS PERIODICALL WITH USE SCREWS MAY BECOME LOOSE.  
CHECK TIGHTNESS OF ALL SCREWS EVERY 6-8 WEEKS.

**MADE IN MALAYSIA**

# ASSEMBLY INSTRUCTION

## STEP 3

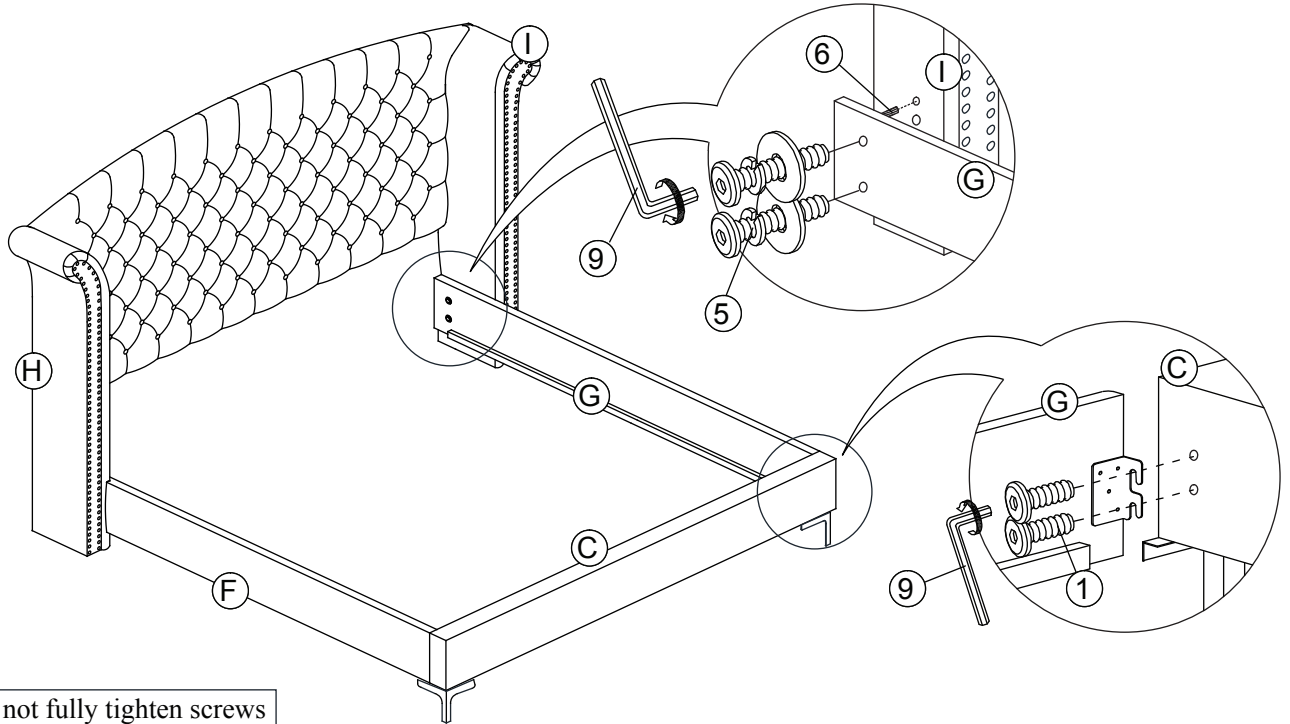

Do not fully tighten screws until assembly is complete and the bed is level.

## STEP 4

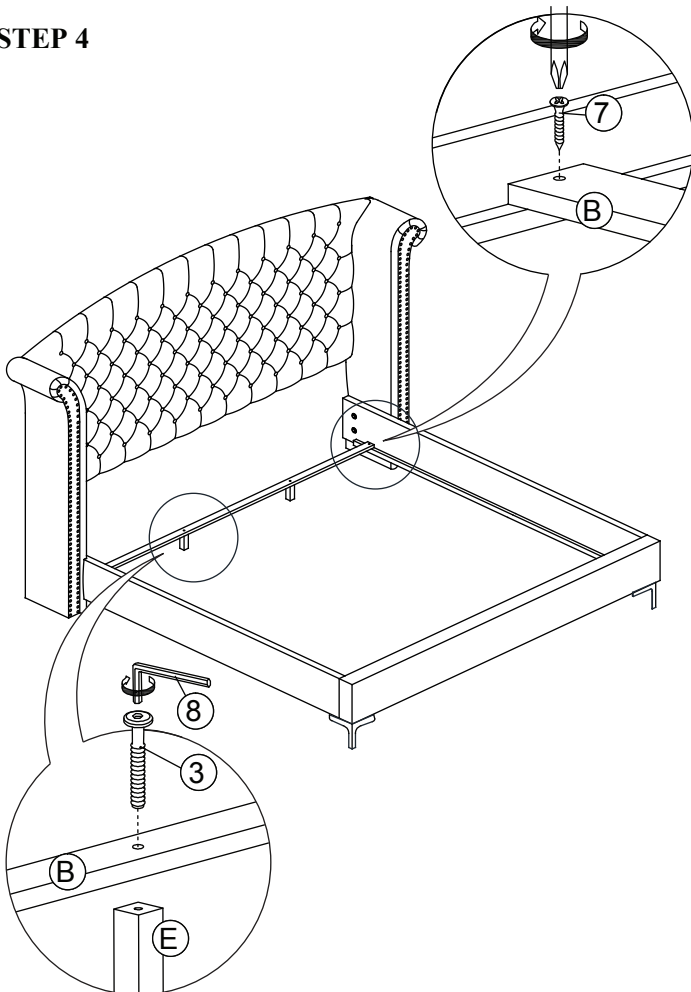

## STEP 5

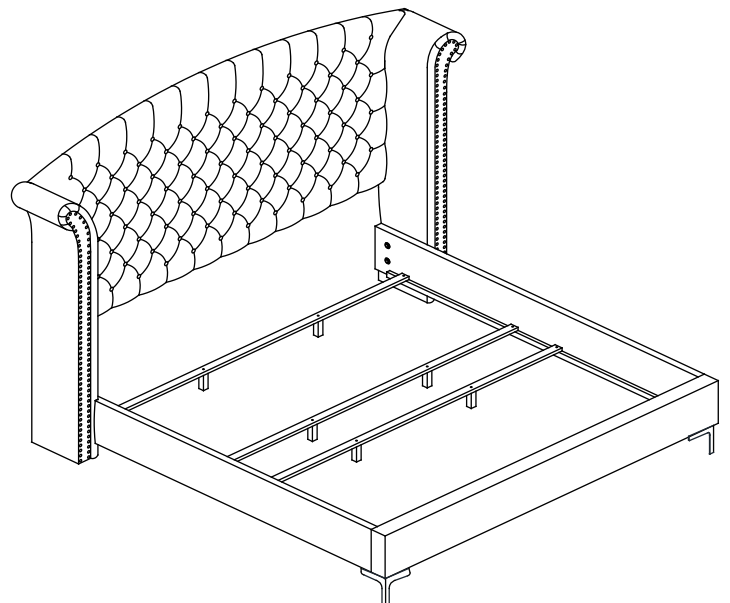

THE HARDWARE ID LOCATED IN THE PACKING ITEMS

NOTE : MUST TIGHT SCREWS PERIODICALL WITH USE SCREWS MAY BECOME LOOSE.  
CHECK TIGHTNESS OF ALL SCREWS EVERY 6-8 WEEKS.

MADE IN MALAYSIA