

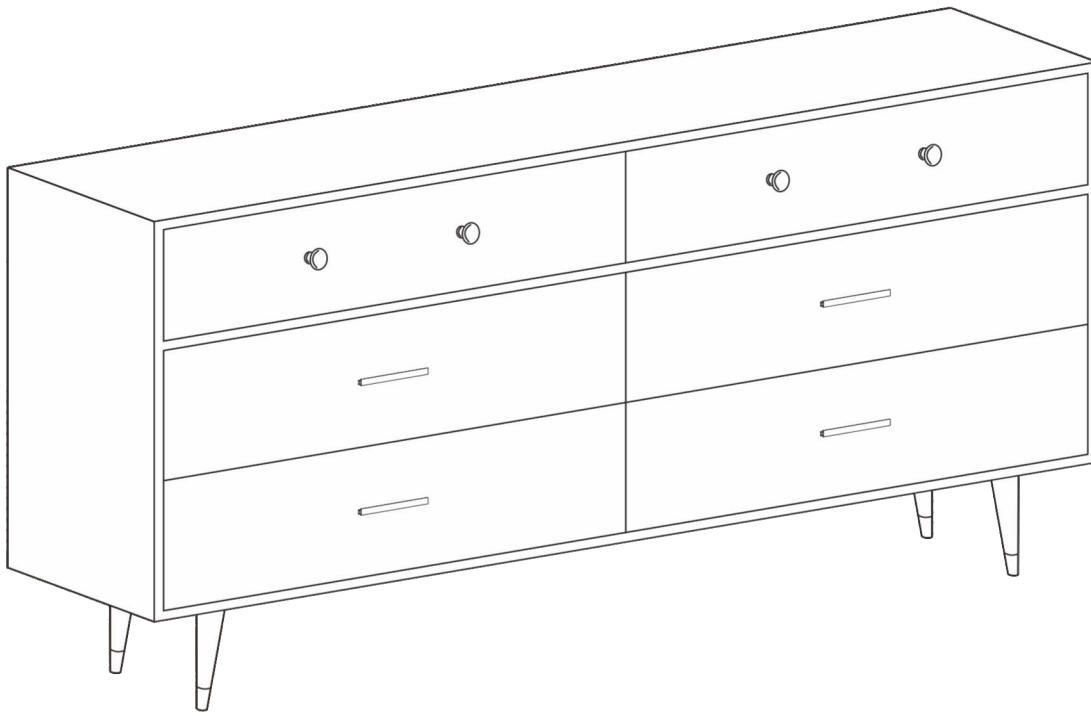

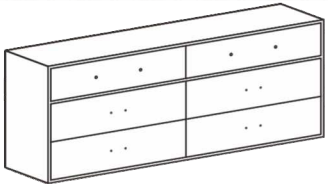

Assembly Instructions



PARTS LIST

NO.:	SKETCH	DESCRIPTION	Qty
A		Cabinet	1
B		Legs	4
C		Long handle	4
D		Round handle	4

HARDWARE LIST

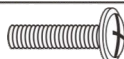
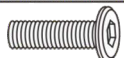
NO.:	SKETCH	DESCRIPTION	Qty
1		Allen Key	1
2		Screw	12
3		Bolt	16

NOTE:

Phillips head screw driver is required in the assembly process; however, manufacturer does not provide this item.

Step 1

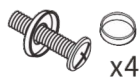
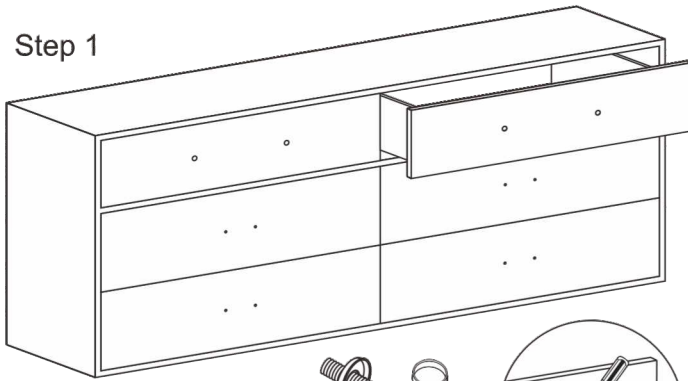

Remove the screws that have been installed in the top two drawers and take out the drawer panels

Step 2 Install the round handles on the two holes in the middle of the drawer panel

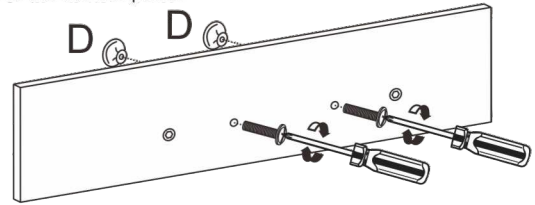

Step 3 Install the drawer panel with the screws removed in the first step.

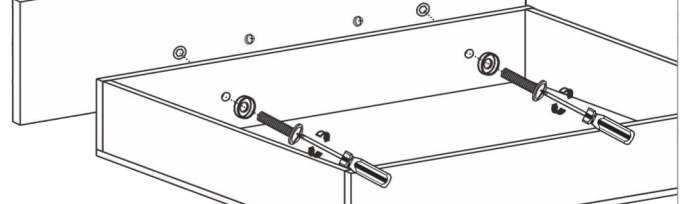

Step 4

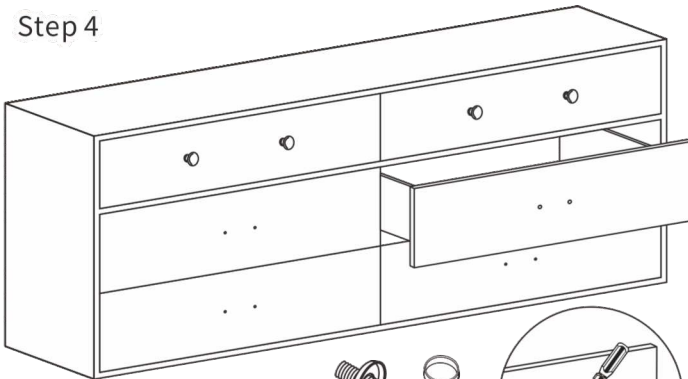

Remove the screws that have been installed in the rest drawers and take out the drawer panels

Step 5 Install the long handles on the two holes in the middle of the drawer panel

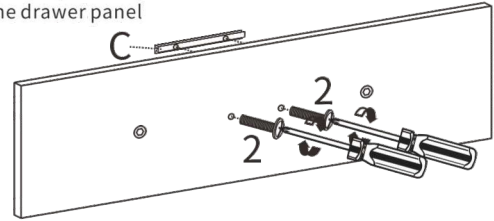

Step 6 Install the drawer panel with the screws removed in the fourth step.

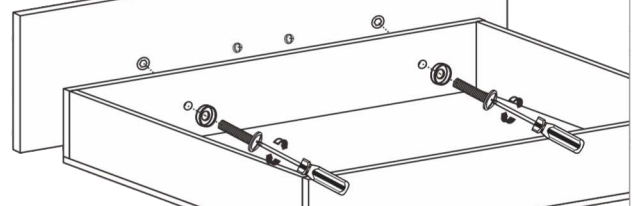

Step 7

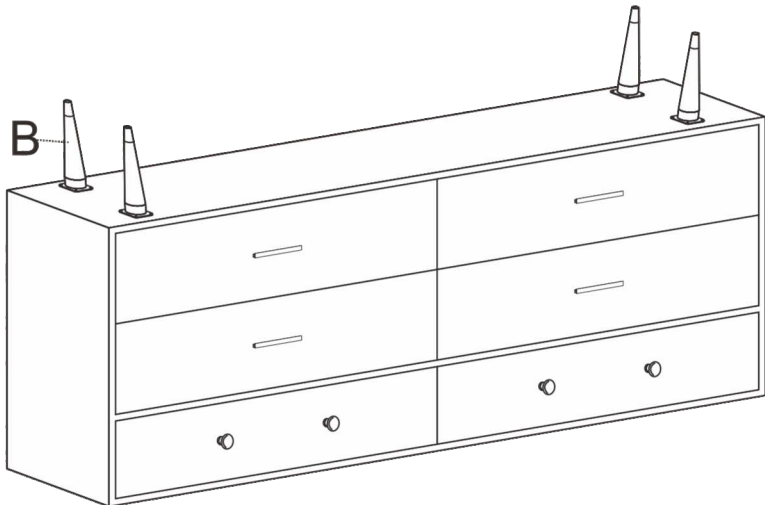
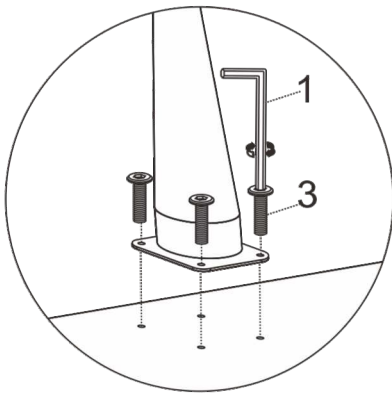

Completed

