

# Armless seat user manual

## Packing list:

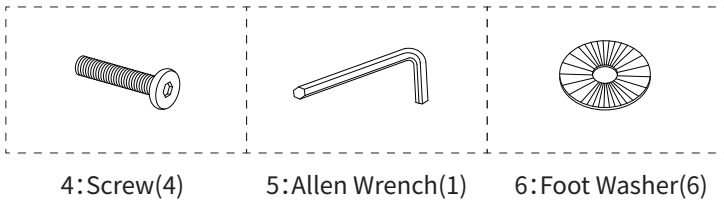

## Step 1:

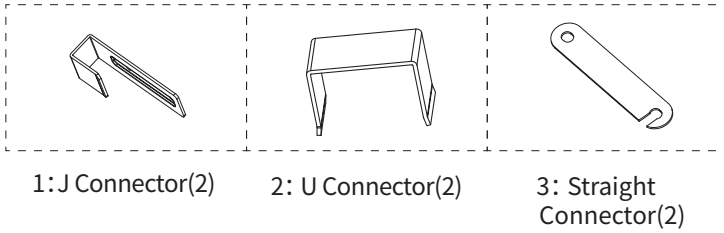
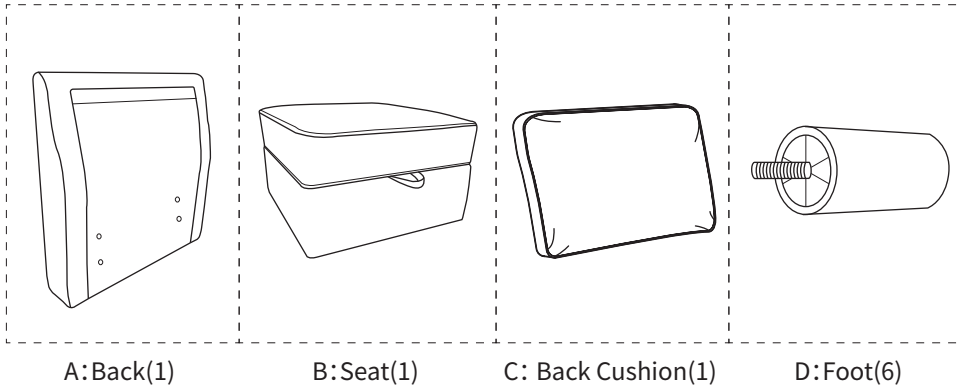
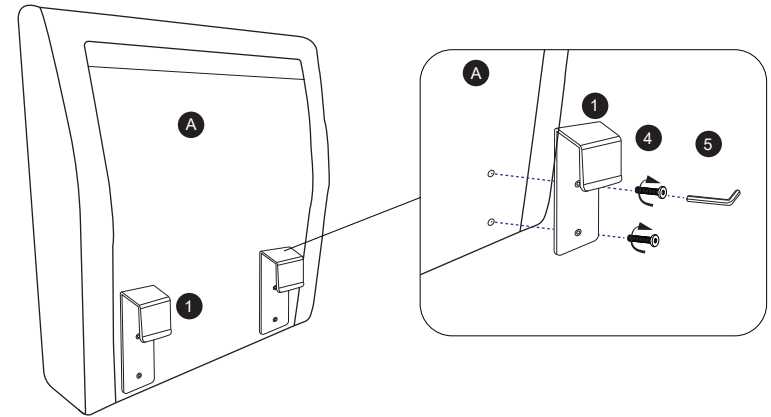

## Step 2:

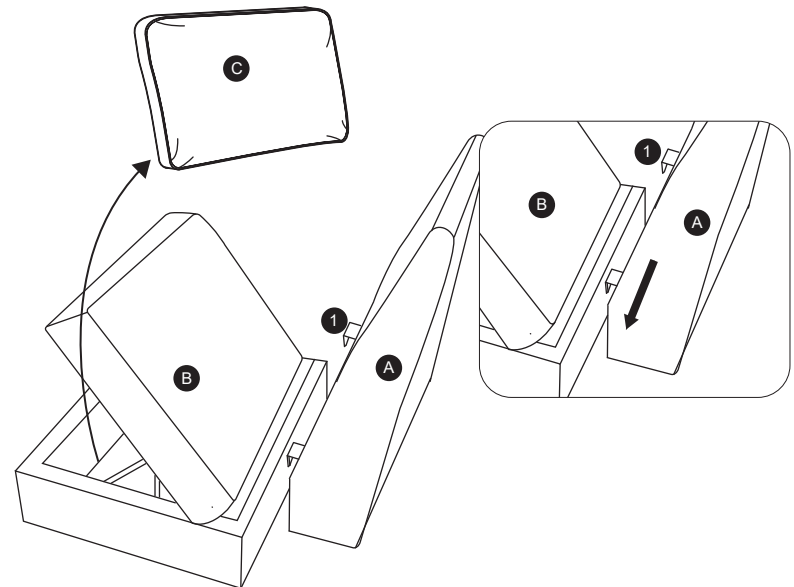

Step 3:

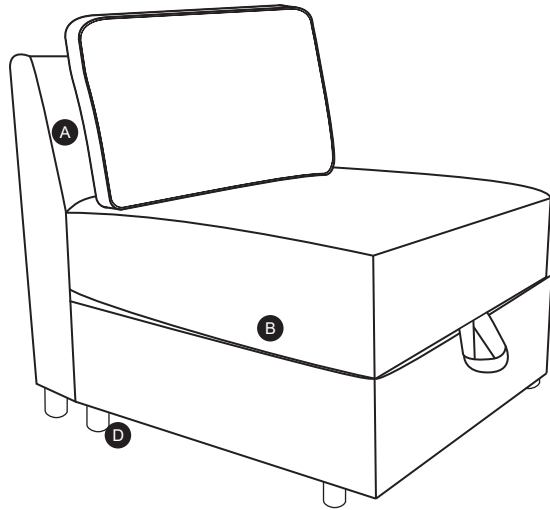
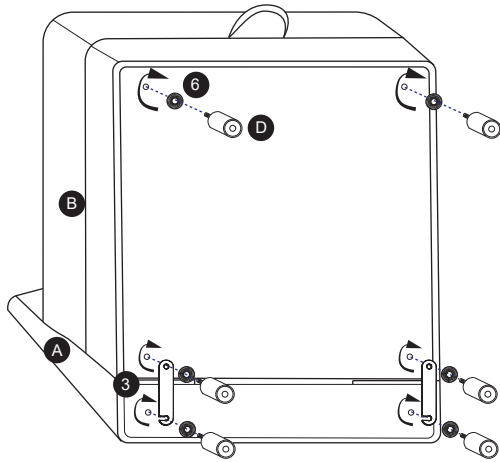

# Arm user manual

## Packing list:

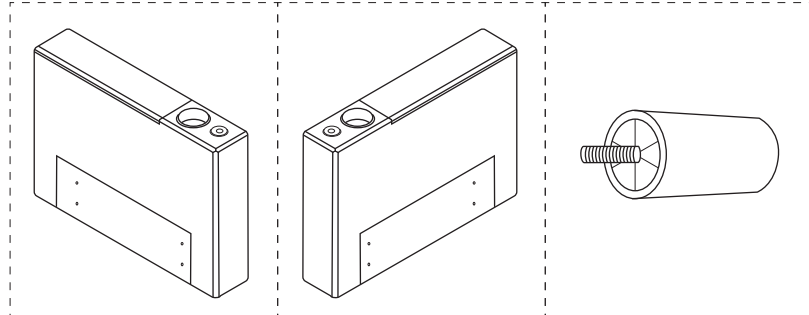

E: Right Facing Arm(1) F: Left Facing Arm(1) D: Foot(4)

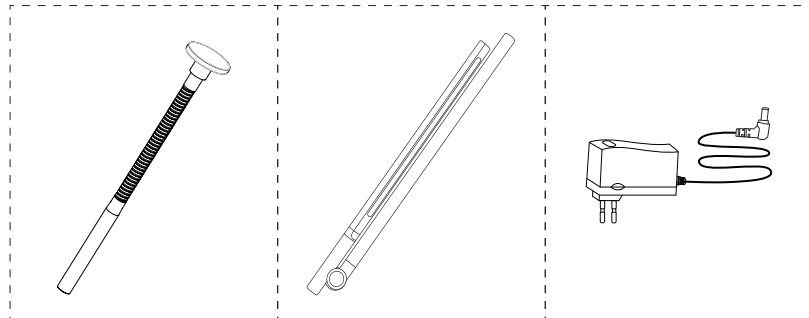

G: Flexible Magnetic Phone Holder(1) H: Articulating Reading Light(1) I: 5V4A Power Cable(2)

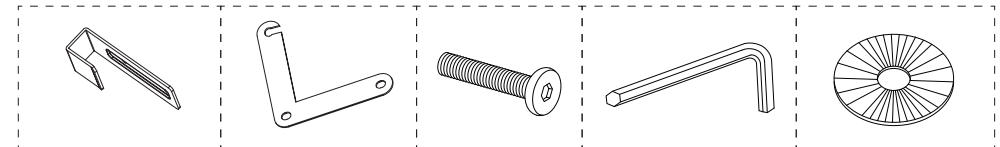

1: J Connector(4) 7: L Connector(2) 4: Screw(8) 5: Allen Wrench(1) 6: Foot Washer(4)

### Step 1:

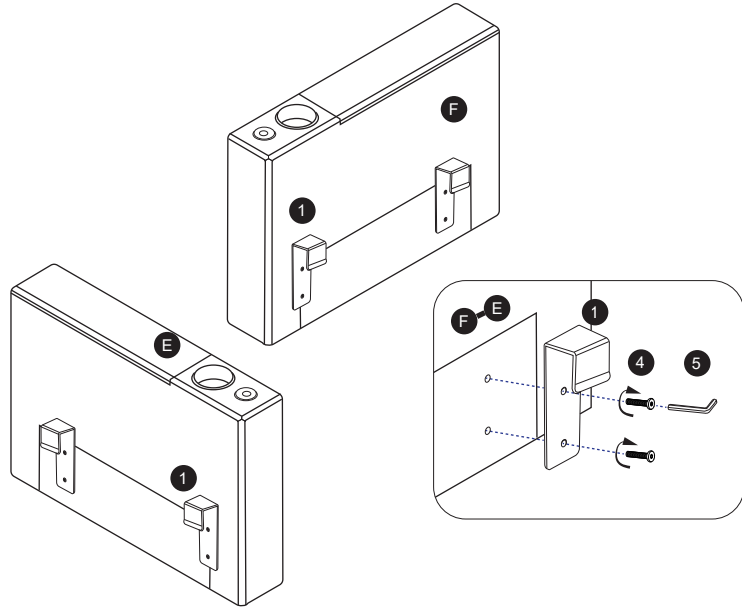

### Step 2:

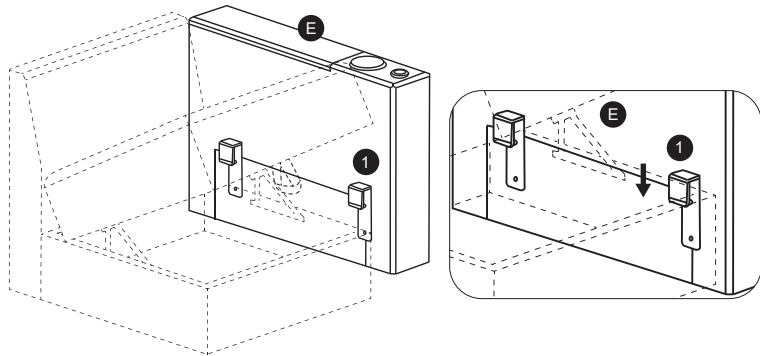

### Step 3:

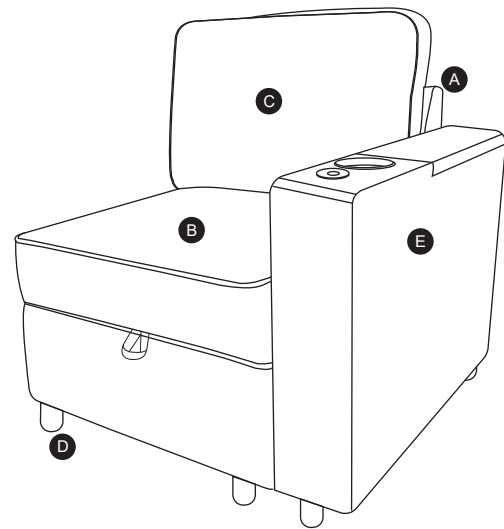
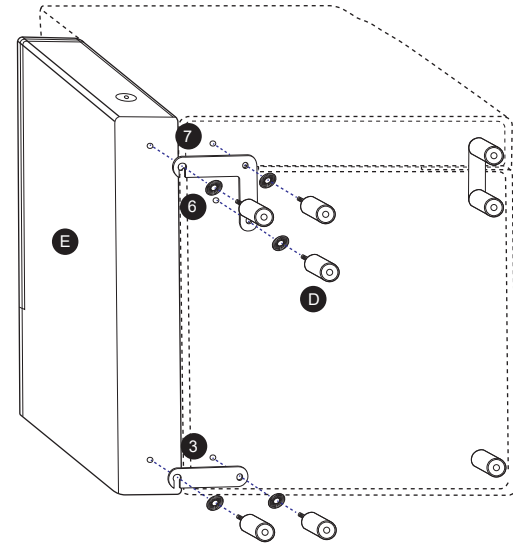

# Armless seat user manual

## Packing list:

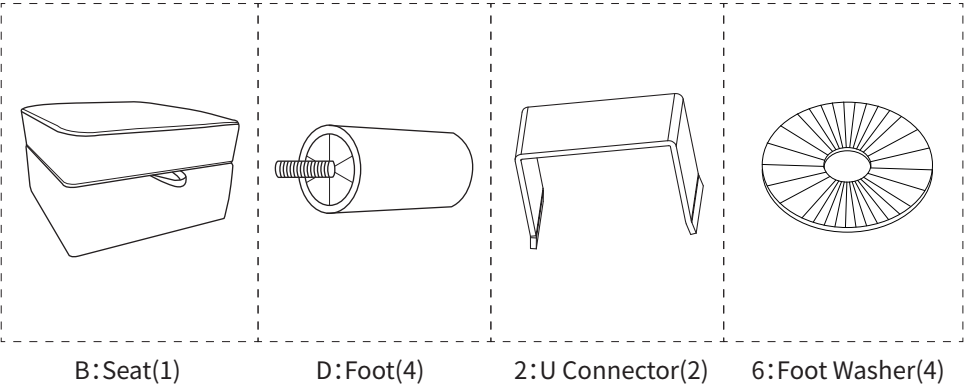

## Step 1:

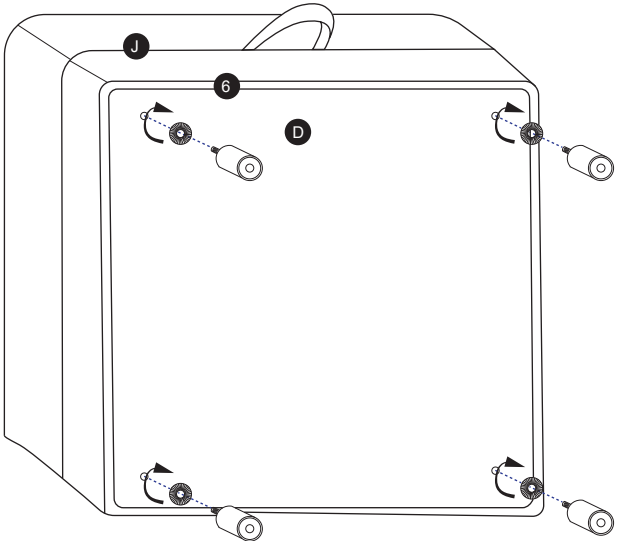

# Operating Instruction

1: Powering your Arm  
Connect the power cable.

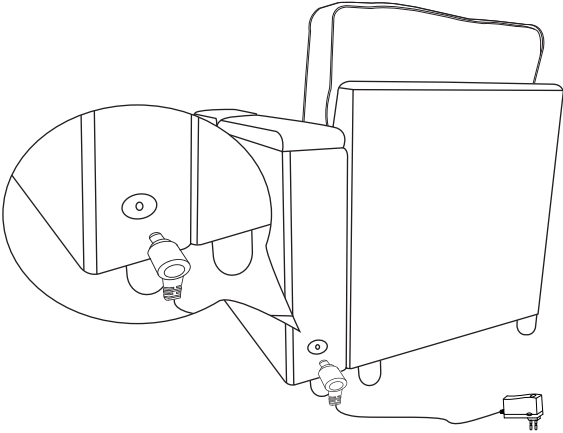
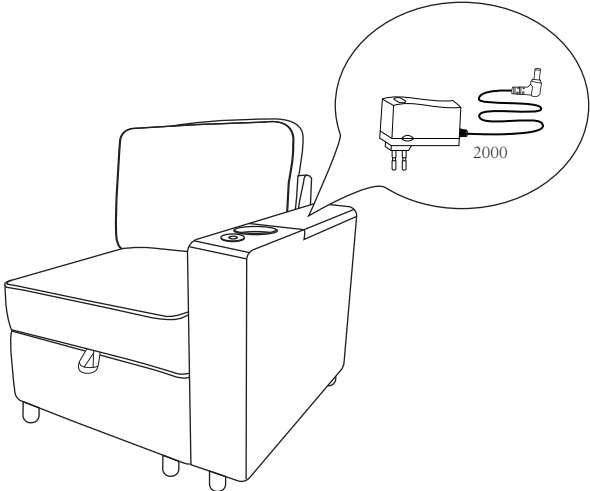

2: Powering your Articulating Reading Light  
Insert the LED light to the Power Grommet

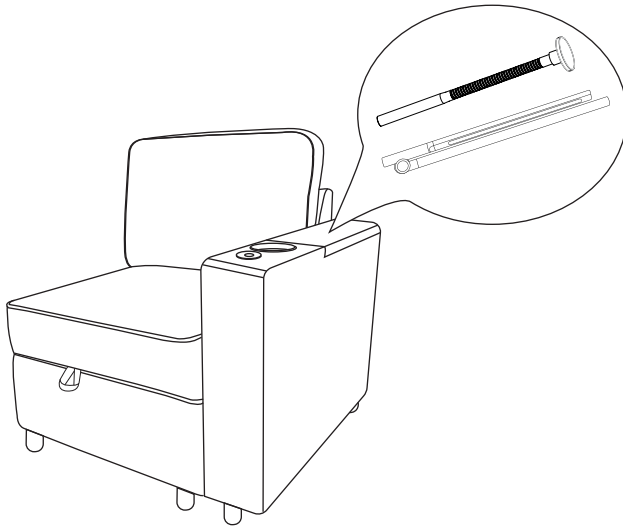

3: Touching area

- 1st touch, turns light to low brightness
- 2nd touch, turns light to high brightness
- 3rd touch, will turn light off.

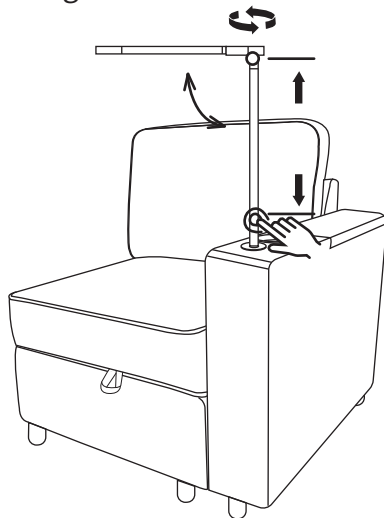

4: Powering your Flexible Magnetic Phone Holder

- a. Insert the Phone Holder into the Power Grommet.
- b. Adjust the Phone Holder to a suitable angle.
- c. Place your compatible smart phone near the magnetic area on the charging holder. It will attract and attach to your phone. Charging will start automatically.

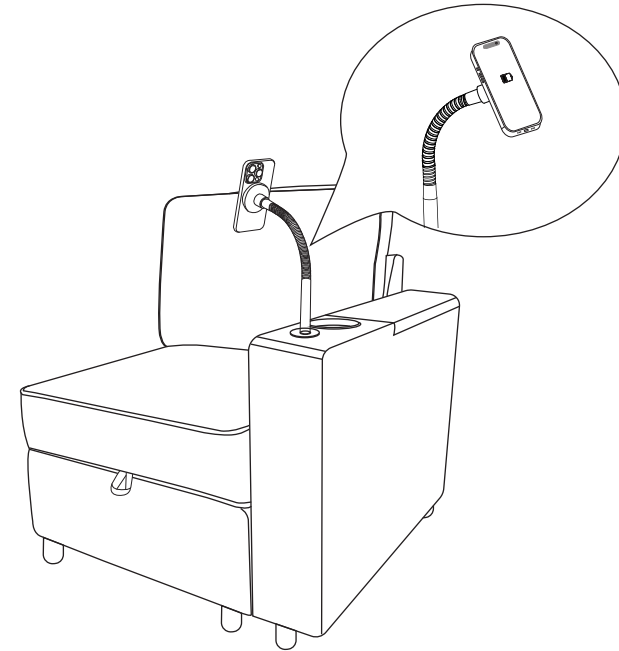

## SAFETY WARNING:

- This product is compatible with iPhone 12-15 series, with MagSafe case or metal ring and Android phones with MagSafe case or metal ring.
- Do not place any foreign objects, including metal pads, magnetic cards, keys, coins, NFC cards, or other metal objects, between the device and the wireless charger's surface. They may demagnetize the wireless charger, affect charging speed, or cause overheating of the charger.
- To ensure stronger magnetic attraction, please use a phone case that contains a magnetic ring.
- When adjusting the phone holder, please remove the phone first to prevent it from falling due to any external forces.
- Magflex Phone Holder and other related electronic products should be kept a minimum of six inches away from implanted medical devices.

## Important Safety Instructions

 DANGER

TO REDUCE THE RISK OF ELECTRIC SHOCK OR SERIOUS INJURY

1. Disconnect the electrical plug from the wall outlet before cleaning, moving, servicing or when not in use for an extended period of time.
2. Do not use this product if it is wet, in water, around water or any liquid.

 WARNING

TO REDUCE THE RISK OF BURNS, FIRE, ELECTRIC SHOCK OR SERIOUS INJURY.

1. Do not stand, sit or place extra weight on the arms.
2. Check the condition of the power transformer, electrical cord, plug, and connectors regularly. Keep the power transformer and electrical cords away from heat sources. Never operate the unit with a damaged power transformer, electrical cord, plug or connector.
3. This product is intended for indoor residential use only.
4. Always keep open flame and lit cigarettes away from upholstered furniture. Upholstered furniture may burn rapidly with toxic gas and thick smoke.

---

### Warranty Limited

---

1. One Year limited warranty of the product.
2. Within 7 days from the date of sale, consumer can choose to repair, replace, or return the product if any structural failure occurs or the fabric cover is damaged under normal use.
3. Any repairs outside of the warranty period, Consumer shall be liable for the shipping cost, any necessary parts, and any cost associated with the repair itself.
4. Please retain this warranty card and invoice for proof of purchase when repairing.

#### **Below issues are not covered by the warranty**

1. The product is not used for its intended use, improper handling.
2. Damage caused by attempted reassembling with others components.
3. Damage caused by force of nature.
4. Damage caused by abnormal indoor / outdoor environment such as exposure to rain, sunlight, high heat / temperature, etc.
5. Product listed on the invoice is not consistent with the product received to be repaired.