

PLANCHA GAS GRILL USER MANUAL

Models:BFEGA83-78

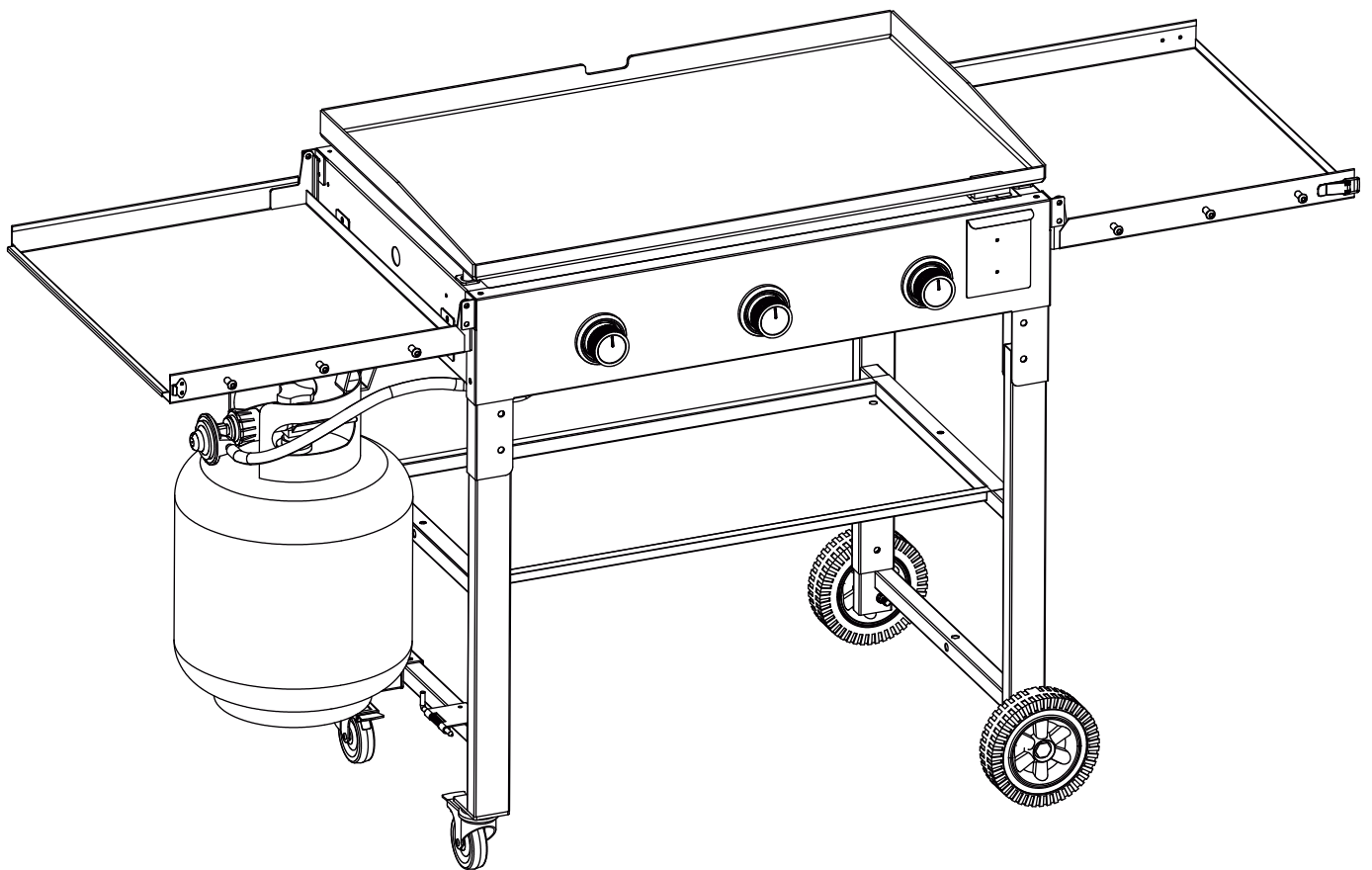

WARNING/DANGER

- Assemble grill on a flat, level, and soft surface.
- Do not use power tools for assembly.
- Use outdoors only!
- Read all precautions and instructions in this manual before using this equipment.
- Save this manual for future reference.
- Keep children and pets away.

CUSTOMER SERVICE

 Service@thebestfire.com

IMPORTANT SAFEGUARDS

⚠ **DANGER: Never operate this appliance unattended.**

⚠ **WARNING: FOR YOUR SAFETY: For Outdoor Use Only (outside any enclosure)**

⚠ **WARNING: FOR YOUR SAFETY**

1. Improper installation, adjustment, alteration, service or maintenance can cause injury or property damage.
2. Read the installation, operation, and maintenance instructions thoroughly before installing or servicing this equipment.
3. Failure to follow these instructions could result in fire or explosion, which could cause property damage, personal injury, or death.
4. This instruction manual contains important information necessary for the proper assembly and safe use of the appliance.
5. Read and follow all warnings and instructions before assembling and using the appliance.
6. Follow all warnings and instructions when using the appliance.
7. Keep this manual for future reference.

⚠ **DANGER: If you smell gas**

1. Shut off gas to the appliance.
2. Extinguish any open flame.
3. Open lid.
4. If odour continues, keep away from the appliance and immediately call your gas supplier or your fire department.

⚠ **WARNING:**

1. Do NOT store or use gasoline or other flammable liquids or vapours in the vicinity of this or any other appliance.
2. An LP cylinder not connected for use shall NOT be stored in the vicinity of this or any other appliance.

⚠ **DANGER:** Failure to follow the dangers, warnings and cautions in this manual may result in serious bodily injury or death, or in a fire or an explosion causing damage to property.

This griddle is for outdoor use only, and should not be used in a building, garage or any other enclosed area.

⚠ Do NOT operate, light or use this appliance within ten feet (3.05 m) of walls, structures or buildings.

⚠ For residential use only. This griddle is NOT for commercial use.

⚠ This griddle is not intended for and should never be used as a heater. TOXIC fumes can accumulate and cause asphyxiation.

⚠ This griddle is safety certified for use in the United States and/or Canada only. Do NOT modify for use in any other location. Modification will result in a safety hazard and will void your warranty.

⚠ This griddle is for use with liquid propane (LP) gas only. The conversion to or attempted use of natural gas in this LP gas griddle is dangerous, may cause bodily harm and will void your warranty.

⚠ LP gas characteristics:

- a. LP gas is flammable and hazardous if handled improperly. Become aware of the characteristics before using any LP gas product.
- b. LP gas is explosive under pressure, heavier than air, and settles/pools in low areas.
- c. LP gas in its natural state has no odor. For your safety, an odorant is added that smells like rotten cabbage.
- d. Contact with LP gas can cause freeze burns to skin.

⚠ Apartment dwellers: Check with management to learn the requirements and fire codes for using a LP gas griddle in your apartment complex. If allowed, use outside on the ground floor with a ten foot (3.05 m) clearance from any structure. Do NOT use on or under balconies.

⚠ LP gas cylinder needed to operate. Only cylinders marked “propane” .

⚠ with the Specifications for LP-gas Cylinders of the U.S. Department of Transportation (D.O.T.) or the National Standard of Canada, CAN/CSA-B339, Cylinders, Spheres and Tubes for the Transportation of Dangerous Goods; and Commission.

⚠ LP gas cylinder must be arranged for vapor withdrawal.

⚠ The LP gas cylinder must have a listed overfilling prevention device(OPD).

⚠ Only use LP gas cylinders equipped with a cylinder connection device compatible with the connection for outdoor cooking appliances.

⚠ The LP gas cylinder must have a cylinder collar to protect the cylinder valve.

⚠ Never use an LP gas cylinder with a damaged body, valve, collar or footing.

⚠ Dented or rusted LP gas cylinders may be hazardous and should be checked by your LP gas supplier prior to use.

⚠ The LP gas cylinder should not be dropped or handled roughly.

⚠ LP gas cylinders must be stored outdoors out of the reach of children and must not be stored in a building, garage or any other enclosed area. Your cylinder must never be stored where temperatures can reach over 125°F.

⚠ Do NOT insert any tool or foreign object into the valve outlet or safety relief valve. You may damage the valve and cause a leak. Leaking propane may result in an explosion, fire, severe personal injury or death.

⚠ Do NOT block holes in sides or back of griddle.

⚠ Never keep an LP gas cylinder in a hot car or trunk. Heat will cause the gas pressure to increase, which may open the relief valve and allow gas to escape.





IMPORTANT SAFEGUARDS



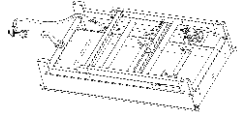
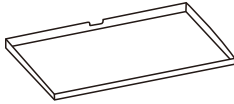

- △ Place dust cap on cylinder valve outlet whenever the cylinder is not in use. Only install the type of dust cap on the cylinder valve outlet that is provided with the cylinder valve. Other types of caps or plugs may result in leakage of propane. If griddle is not in use, the gas must be turned off at the supply cylinder and disconnected.
- △ Do NOT store a spare LP gas cylinder under or near this appliance.
- △ Never fill the cylinder beyond 80 percent full.
- △ If the information above is not followed exactly, a fire causing death or serious injury could occur. A fire causing serious injury or damage to property may occur if the above is not followed exactly.
- △ Never attempt to attach this griddle to the self-contained LP gas system of a camper trailer, motor home or house.
- △ Never use charcoal, lighter fluid, lava rocks, gasoline, kerosene or alcohol with this product.
- △ Your griddle has been checked at all factory connections for leaks. Re-check all connections as described in the “Operating Instructions” section, as shipping can loosen connections.
- △ Check for leaks even if your unit was assembled for you by someone else.
- △ Do NOT operate if a gas leak is present. Gas leaks may cause a fire or explosion.
- △ You must follow all instructions in the “Checking for Leaks” section before operating. To prevent fire or explosion hazard when testing for a leak:
 - a. Always perform a leak test before lighting the griddle and each time the cylinder is connected for use.
 - b. No smoking. Do NOT use or permit sources of ignition in the area while conducting a leak test.
 - c. Conduct the leak test outdoors in a well-ventilated area.
 - d. Do NOT use matches, lighters, or a flame to check for leaks.
 - e. The use of alcohol, prescription or non-prescription drugs may impair the consumer’s ability to properly assemble or safely operate the appliance.
 - f. Strong odors, colds, sinus congestion, etc. may prevent the detection of propane. Use caution and common sense when testing for leaks.
 - g. Do NOT use griddle until any and all leaks are corrected. If you are unable to stop a leak, disconnect the LP gas supply. Call a gas appliance serviceman or your local LP gas supplier.
- △ This griddle is designed to operate at an inlet pressure of: 11 inches water column.
- △ Do NOT store or use gasoline or other flammable liquids or vapors within 25 feet (7.62 m) of this appliance.
- △ Do NOT use in an explosive atmosphere. Keep griddle area clear and free from combustible materials, gasoline and other flammable vapors and liquids.
- △ Minimum clearance from sides and back of unit to combustible construction is 36 inches (91.4 cm). Do NOT use this appliance under any type of overhang or roof.
- △ It is essential to keep the griddle’s valve compartment, burners and circulating air passages clean.
- △ Inspect griddle before each use.
- △ Do NOT alter griddle in any manner. Any alteration will void your warranty.
- △ Do NOT use the griddle unless it is COMPLETELY assembled and all parts are securely fastened and tightened.
- △ Do NOT build this model of griddle in any built-in or slide-in construction. Ignoring this warning could cause a fire or an explosion that can damage property and cause serious bodily injury or death.
- △ This griddle should be thoroughly cleaned and inspected on a regular basis.
- △ Clean and inspect the hose before each use of the appliance. If there is evidence of abrasion, wear, cuts or leaks, the hose must be replaced prior to operation.
- △ Use only the regulator and hose assembly provided. Use only the replacement regulator and hose assembly specified by zhejiang lumbre electrical appliance co. Limited
- △ Use only Zhejiang Lumbre Electric Appliance Co. Limited factory-authorized parts. The use of any part that is not factory-authorized can be dangerous and will void your warranty.
- △ Do NOT operate this appliance without reading “Operating Instructions” in this manual.
- △ Do NOT touch metal parts of griddle until they have completely cooled to avoid burns, unless you are wearing protective gear (pot holders, gloves, BBQ mittens, etc.).
- △ Do NOT install or use in or on boats or recreational vehicles.
- △ When cooking, fire extinguishing materials should be readily accessible. In the event of an oil/grease fire, do NOT attempt to extinguish with water. Use type BC dry chemical fire extinguisher or smother with dirt, sand or baking soda.
- △ Do NOT use griddle in high winds.
- △ Never lean over the griddle when lighting.
- △ Do NOT leave a lit griddle unattended. Keep children and pets away from griddle at all times.
- △ Do NOT leave griddle unattended while preheating or burning off food residue on high. If griddle has not been cleaned, a grease fire can occur that may damage the product.
- △ Do NOT place empty cooking vessels on the appliance while in operation.
- △ Use caution when placing anything on the griddle while the appliance is in operation.
- △ Do NOT attempt to move griddle when in use. Allow the griddle to cool before moving or storing.
- △ LP gas cylinder must be properly disconnected and removed prior to moving this griddle.

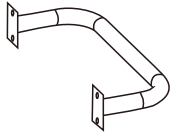
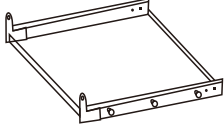
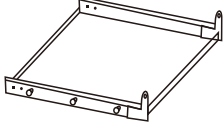
IMPORTANT SAFEGUARDS

- △ Storage of griddle indoors is permissible only if the cylinder is disconnected, removed from the griddle and properly stored outdoors.
- △ The LP gas cylinder must have a cylinder connection device compatible with the connection for outdoor cooking appliances.
- △ An appliance is considered to be outdoors if installed with shelter no more inclusive than with walls on three sides, but with no overhead cover; all openings must be permanently open; sliding doors, garage doors, windows, or screened openings are not considered as permanent openings”
- △ An appliance is considered to be outdoors if installed with shelter no more inclusive than within a partial enclosure that includes an overhead cover and no more than two sidewalls. the sidewalls may be parallel, as in a breezeway, or at right angles to each other; all openings must be permanently open; sliding doors, garage doors, windows, or screened openings are not considered as permanent openings” must have a cylinder connection device compatible ”.
- △ An appliance is considered to be outdoors if installed with shelter no more inclusive than within a partial enclosure that includes an overhead cover and three sidewalls, as long as 30% or more of the horizontal permanently open; sliding doors, garage doors, windows, or screened openings are not considered as permanent openings”
- △ Do NOT attempt to disconnect the gas regulator from the cylinder or any gas fitting while the griddle is in use.
- △ Always place your griddle on a hard, non-combustible, level surface. An asphalt or blacktop surface may not be acceptable for this purpose.
- △ Move gas hoses as far away as possible from hot surfaces and dripping hot grease.
- △ Keep all electrical cords away from a hot griddle.
- △ After a period of storage and/or nonuse, check for leaks, burner obstructions and inspect for any abrasion, wear or cuts to the hose.
- △ Failure to open side shelves while igniting the griddle’s burners, or not waiting 5 minutes to allow the gas to clear if the griddle does not light, may result in an explosive flame-up.
- △ Always use a meat thermometer to ensure food is cooked to a safe temperature.
- △ Use protective gloves when assembling this product.
- △ Do NOT force parts together as this can result in personal injury or damage to the product.
- △ Never cover entire cooking area with aluminum foil.
- △ Deaths, serious injury or damage to property may occur if the above is not followed exactly.
- △ This gas griddle is not to be installed in or on boats. This appliance is not to be installed in or on recreational vehicles.
- △ The minimum ambient operating temperature for safe use of the Outdoor LP Gas Griddle Model No. EGA83-78 appliance -20°C(-4°F)
- △ This griddle must not be used under overhead combustible construction.

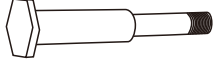
PART LIST

	Name	Pic	Qty
A	Griddle Body Assembly		x1
B	Griddle Surface		x1
C	Bottom Shelf		x1
D	Side Handle		x2
E	Right Side Shelf		x1
F	Left Side Shelf		x1
G	Control Knob		x3

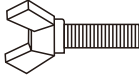
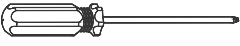
	Name	Pic	Qty
H	Latch		x2
I	M8 Screws		x2
J	Wheel		x2
K	M6 X 14 mm Screw		x12
L	Lock Nut		x4
M	M6 X 16 mm Screw		x2
N	Phillips Head Screwdriver		x1

ASSEMBLY INSTRUCTIONS

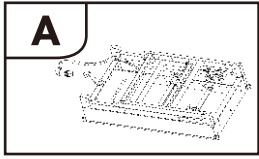

Griddle Body
Assembly x 1

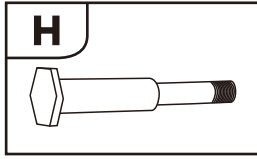

Latch x 2

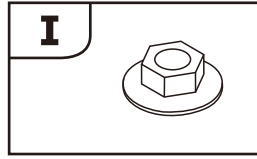

M8 Screws x 2

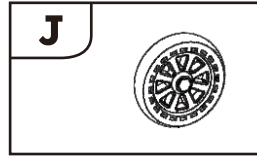

Wheel x 2

Assembly Tips:

1. Select an area where you will assemble this product. To protect components, choose a smooth surface that's free of cracks or openings.
2. Spread out all parts.
3. Tighten all hardware connections by hand first. Then, before completing each step, go back and fully tighten all hardware. Be careful not to over-tighten. That could damage surfaces or strip threads.
4. For best results, complete each step in the order presented.

To complete assembly you will need:

- (1) Leak detection solution (instructions on how to make the solution are included in the "Operating Instructions" section of this manual).
- (1) Precision-filled LP gas grill tank with Acme Type 1 external threaded valve connection (standard grill size) (not included). Typical assembly is approximately one hour.

⚠ CAUTION: Two (2) people are required for assembly

Install Wheel Using M8 Screws

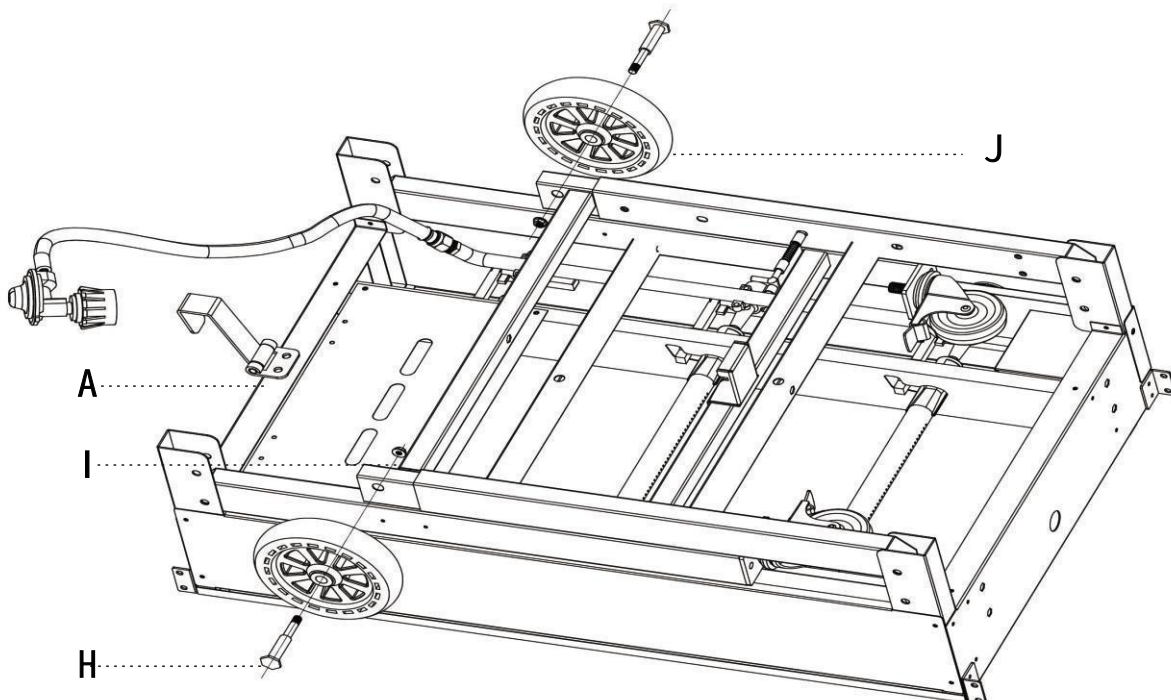

ASSEMBLY INSTRUCTIONS

STPE 2:

Caution:Two(2)people will be required to lay griddle on back.

Note:Open Right Legs First.

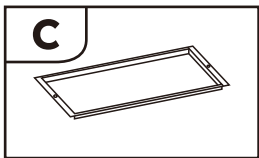
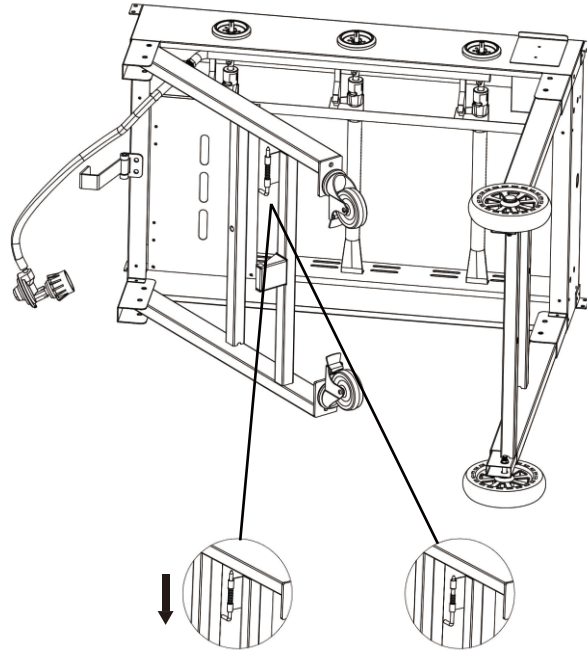

Bottom Shelf x 1

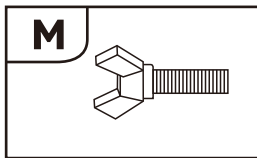

M6 X 16 mm
Screw x 2

STPE 3:

Attach Bottom Shelf

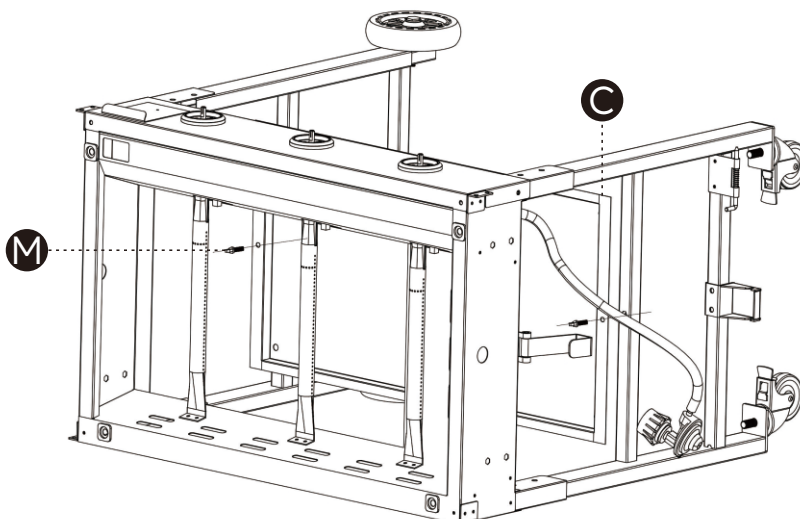

ASSEMBLY INSTRUCTIONS

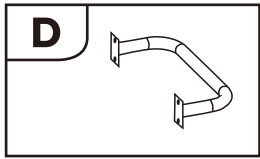

Side Handle x 2

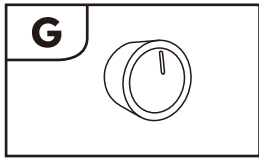

Control Knob x 3

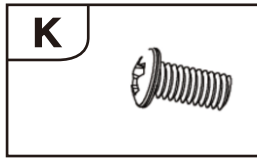

M6 X 14 mm
Screw x 8

STEP 4:

Attach Side Handles and Insert Control Knobs

CAUTION: Two (2) people will be required to stand griddle upright.

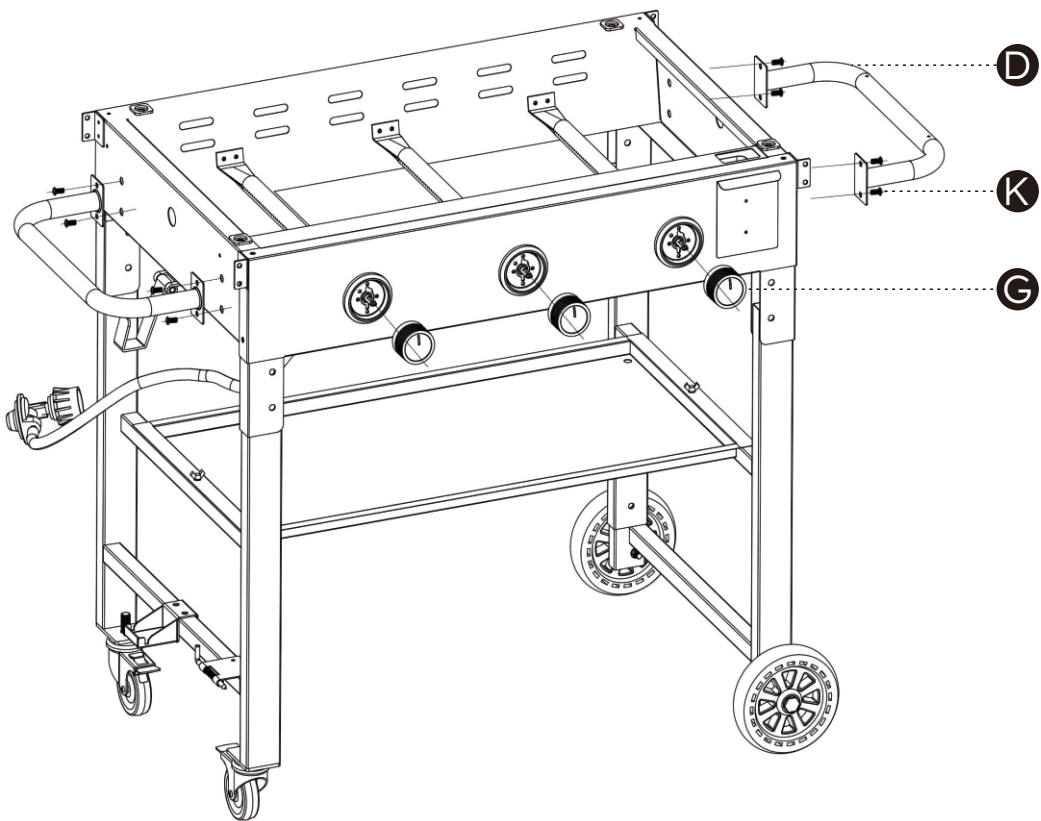

ASSEMBLY INSTRUCTIONS

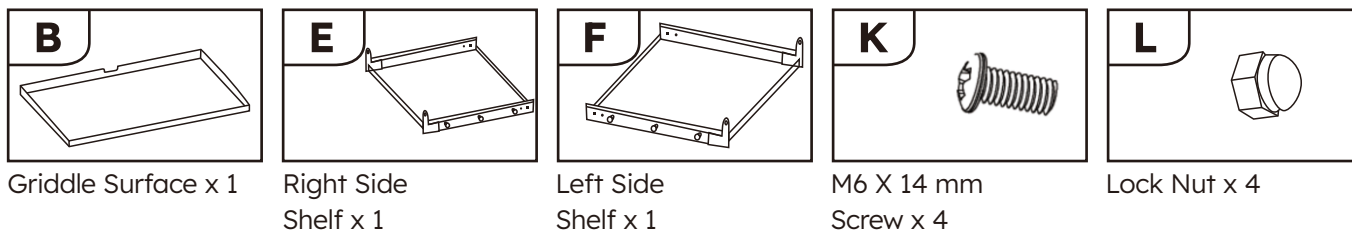

STPE 5:

Attach Right Side Shelf And Left Side Shelf.Place The Griddle

CAUTION: Maximum side shelf weight is 33 lbs (15 kg).

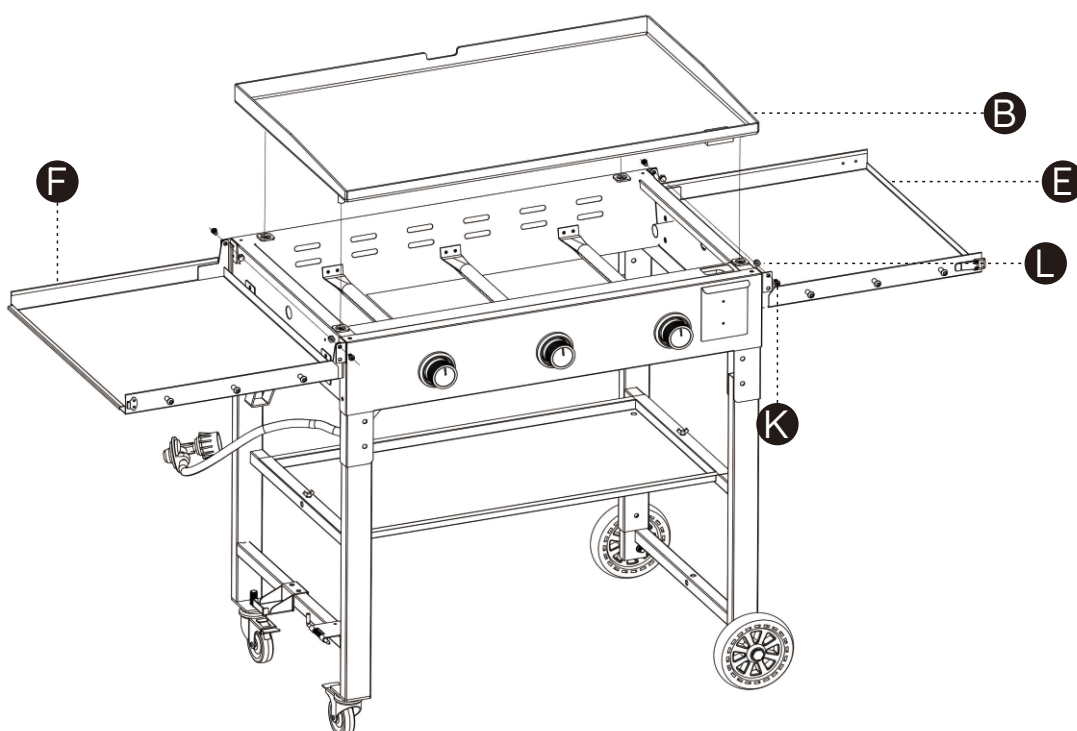

⚠ The replacement hose assembly shall be specified by the manufacturer

⚠ **IMPORTANT** Before first use and after each use,always season your griddle per "Seasoning Griddle"Section

ASSEMBLY INSTRUCTIONS

⚠ WARNING: Before transporting or storing this griddle:

- a. Always season griddle per “Seasoning Griddle” section.
- b. Always clean griddle per “Cleaning Instructions” section.
- c. Always wait until griddle is cool.
- d. Always turn griddle off per “Turning Off” section.
- e. Always disconnect tank per “Disconnecting LP Gas Tank” section.
- f. Always empty and properly dispose of all items in grease cup.

⚠ WARNING: When transporting or storing this unit, always follow the instructions found in this section.

⚠ CAUTION: Two (2) people will be required to prepare for transportation and/or storage.

STPE 1:

Remove Griddle Surface

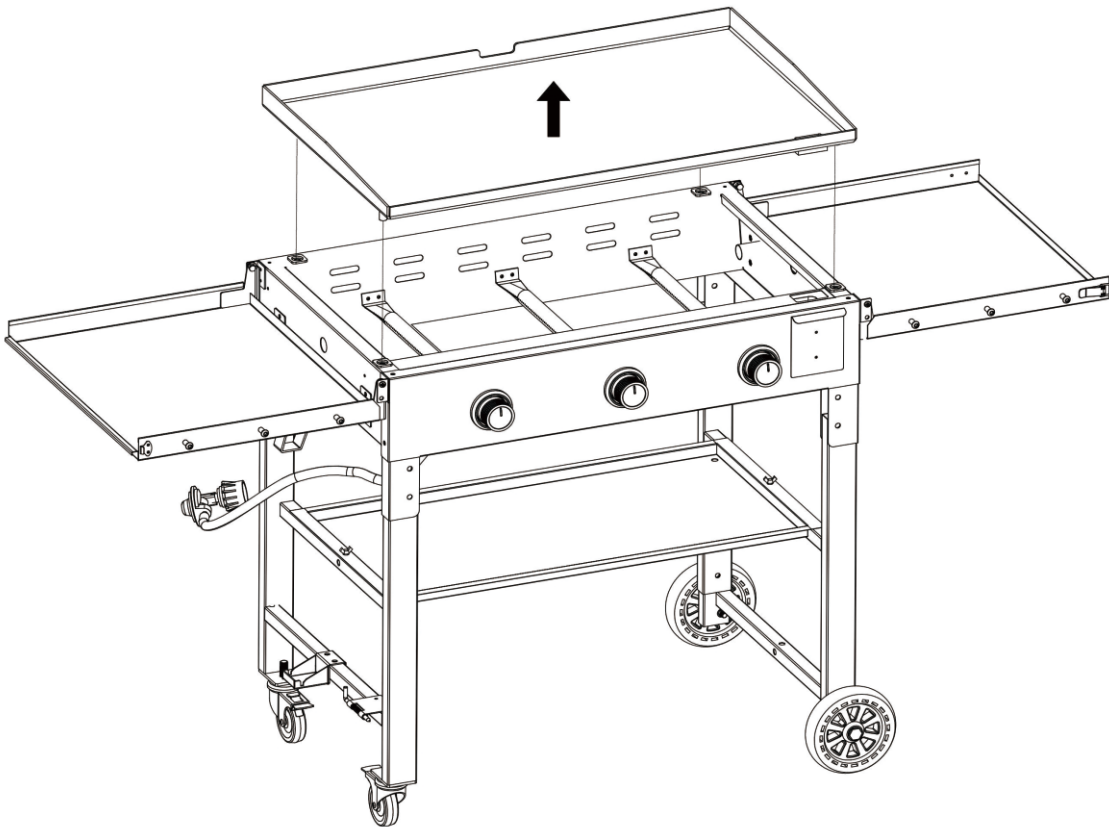

ASSEMBLY INSTRUCTIONS

STPE 2:

Remove Bottom Shelf

⚠ CAUTION: Two (2) people will be required to lay griddle on back.

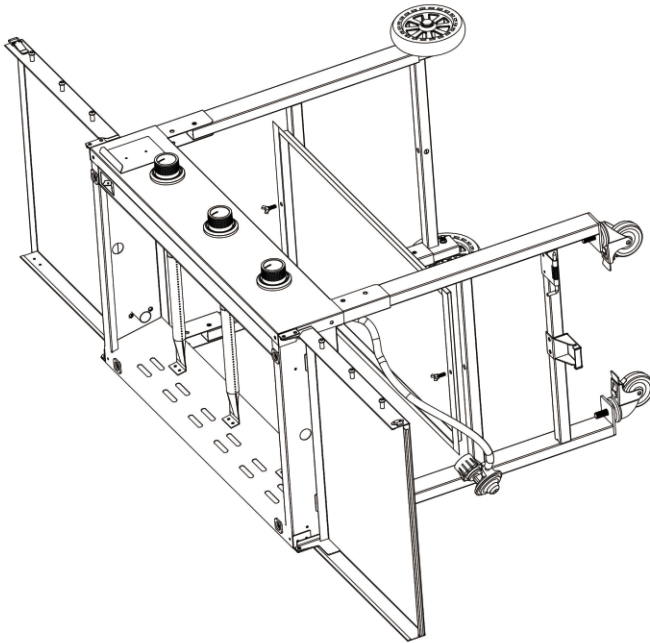

STPE 3:

Close Legs

⚠ NOTE: Close Left Leg First.

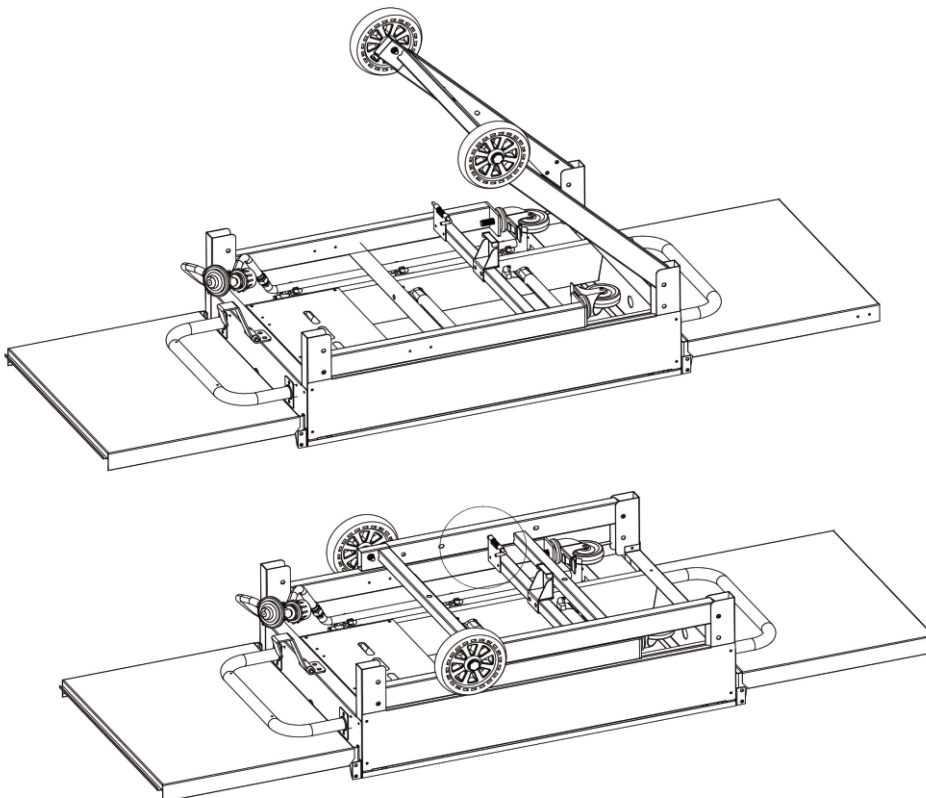

ASSEMBLY INSTRUCTIONS

STPE 4:

Unscrew the Right Leg

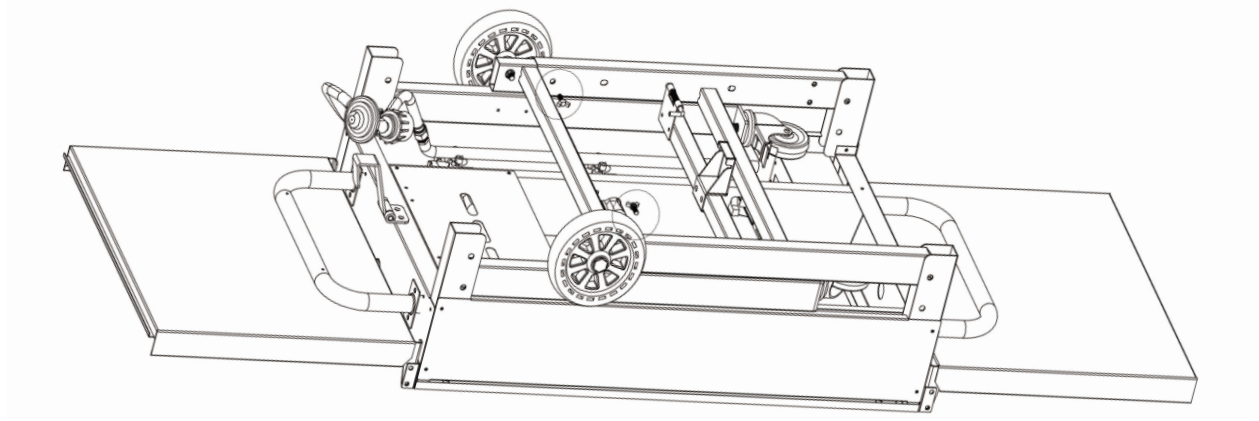

STPE 5:

Pull the Right leg,fixing the screw to the second hole.

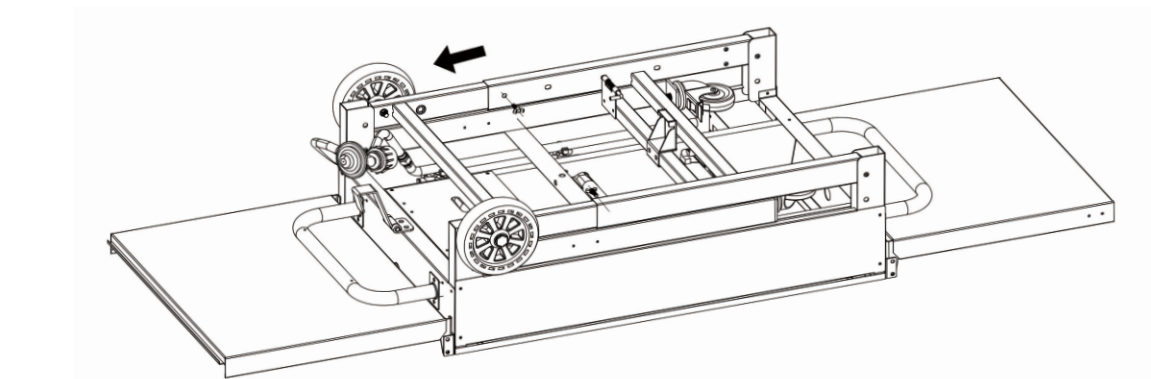

STPE 6:

Place The Griddls Sureface

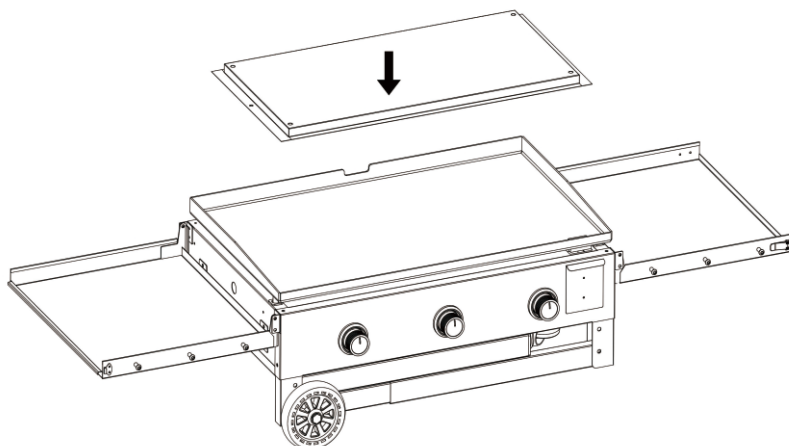

ASSEMBLY INSTRUCTIONS

STPE 7:

Close Side Shelves

Openclose left side shelf first, then right side shelf

⚠CAUTION: Hold side shelf securely while opening. Do NOT release until fully colsed.

⚠CAUTION: Maximum side shelf weight is 33 lbs (15 kg).

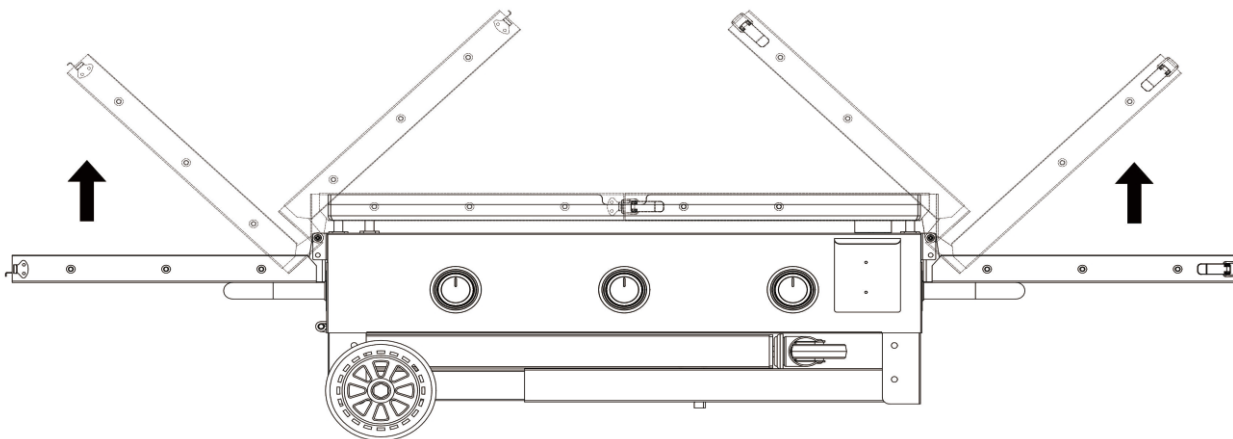

Lock Side Shelves

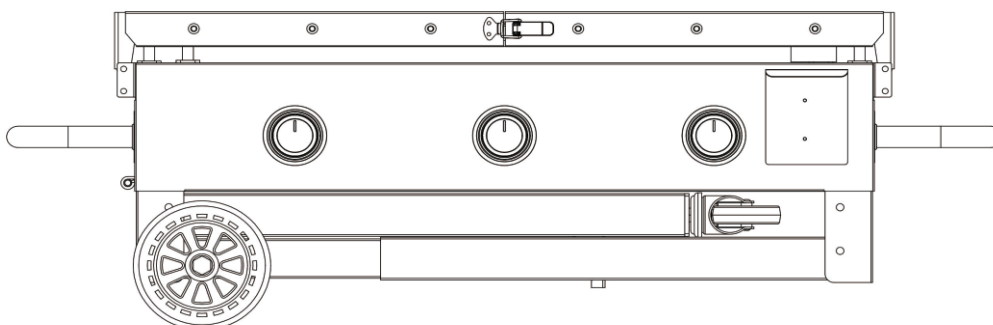

ASSEMBLY INSTRUCTIONS

Connecting LP Gas Tank

1. Make sure control knobs are in the "OFF" position (Figure 2).
2. Before connecting, be sure there is no debris caught in the head of the LP gas tank, head of the regulator valve or in the head of the burner or burner ports.
3. Connect regulator/hose assembly to tank by turning knob clockwise until it stops.
4. Perform leak test per "Checking for Leaks" section.

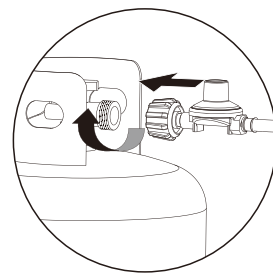

Disconnecting LP Gas Tank

1. Make sure control knobs are in the "OFF" position (Figure 2).
2. Before disconnecting, make sure the LP gas tank valve is "CLOSED".
3. Disconnect regulator/hose assembly from LP gas tank by turning knob counterclockwise until it is loose.

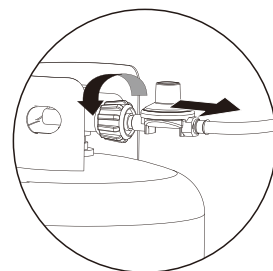

⚠ CAUTION: LP gas tank must be properly disconnected and removed prior to moving this griddle.

4. Place the protective cap cover on the LP tank and store the tank outdoors in a well ventilated area out of direct sunlight the cylinder face elastomeric face seal element on these devices could, over time, show marked and visible damage or deterioration that might cause a leak even with the connection tightened; A visual inspection for the seal must be carried out every time a LP gas cylinder is replace or refilled; that any LP-gas cylinder showing signs of damage or deterioration as those illustrated in figure. including visible cracks and pitting ,must be returned unused to the seller.

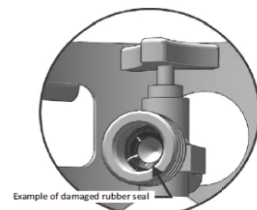
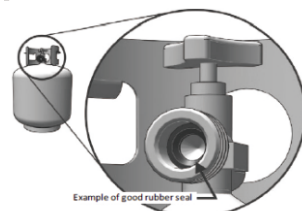

Installing LP Gas Tank

To operate, you will need one precision-filled standard barbecue grill LP Gas Tank LP gas tank with external valve threads This product is used with 20lb gas cylinders.

⚠ CAUTION: LP gas tank must be properly disconnected and removed prior to moving this griddle.

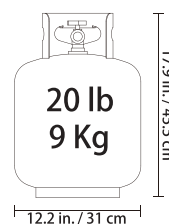

Inserting and Securing LP Gas Tank

1. Unfold the upper LP gas tank support.
2. Place precision-filled LP gas tank upright onto the upper and lower LP gas tank support so the tank valve is facing the gas line connection.

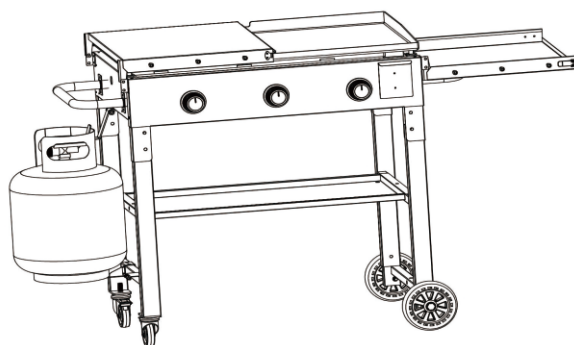
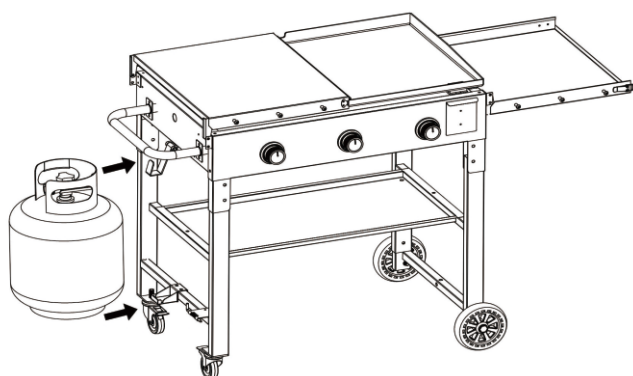
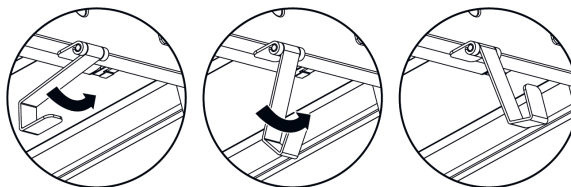

OPERATING INSTRUCTIONS

Checking for Leaks

Burner Connections

1. Make sure the regulator hose and valve connections are securely fastened to the burner and the tank.
2. Visually check the connection between the burner/venturi tube and orifice.
3. Make sure the burner/venturi tube fits over the orifice.

⚠ WARNING: Failure to inspect this connection or follow these instructions could cause a fire or an explosion which can cause death, serious bodily injury or damage to property.

4. Please refer to diagram for proper installation (Figure 1).
5. If the burner/venturi tube does not rest flush to the orifice, as shown, please contact us for assistance.

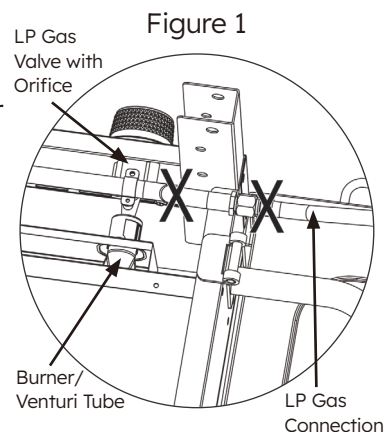

Tank/Gas Line Connection

1. Make 2-3 oz of leak detection solution by mixing one part liquid dish washing soap with three parts water.
2. Make sure control knobs are in the "OFF" position (Figure 2).
3. Connect LP gas tank per "Installing LP Gas Tank" section.
4. Turn LP gas tank valve to "OPEN".
5. Spoon several drops of solution, or use a squirt bottle, at all "X" locations (Figures 1 and 3).
 - a If any bubbles appear, turn LP gas tank valve to "CLOSED," reconnect and re-test.
 - b If you continue to see bubbles after several LP gas tank valve to "CLOSED," wipe away attempts, turn LP gas tank valve to "CLOSED" and disconnect LP gas tank, per "Disconnecting LP Gas Tank" section Contact lumbré grill for assistance.
 - c If no bubbles appear after one minute, turn solution and proceed.

Figure 2

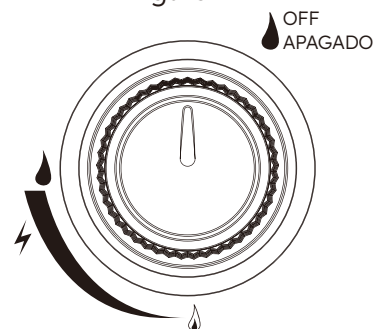
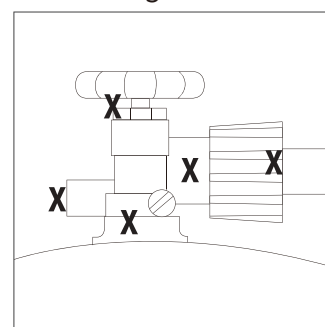

Figure 3



Operating Main Burners

First Use

1. Make sure all labels, packaging and protective films have been removed from the griddle.
2. Light griddle per "Lighting" section.
3. Remove manufacturing oils before cooking on this griddle for the first time.
4. Season your griddle per "Seasoning Griddle" section.

Lighting

- ⚠ CAUTION:** Keep outdoor gas cooking appliance area clear and free from combustible materials, gasoline and other flammable vapors and liquids.
- ⚠ CAUTION:** Do NOT obstruct the flow of combustion and ventilation air.
- ⚠ CAUTION:** Check and clean burner/venturi tubes for insects and insect fire nests. A clogged tube can lead to a.
- ⚠ CAUTION:** Do NOT use non-stick cooking sprays because they contain a lot of water and can burn onto the griddle, damaging the surface.
- ⚠ CAUTION:** Do NOT use corn oil as it contains a high level of sugar, which can caramelize and burn onto the surface.

1. Open side shelves.
2. Check for obstructions of airflow to the burners Spiders, insects and webs can clog the burner/venturi tube A clogged burner tube can lead to a fire.
3. All control knobs must be in the "OFF" position (Figure 2).
4. Connect LP gas tank per "Installing LP Gas Tank" section.

Figure 4

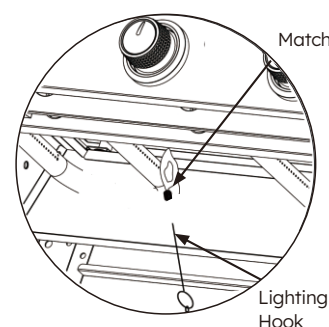
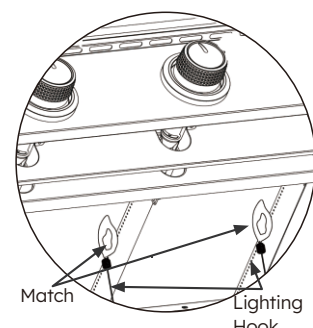

Figure 5



OPERATING INSTRUCTIONS

5. Turn LP gas tank valve to “OPEN”.
6. Push and turn any control knob to (HIGH) The burner should light. If it does not, repeat up to.
7. three times burner control knob “ OFF,” wait 5 minutes, and repeat lighting procedure.
8. If igniter does not light burner, use a lit match secured with the Lighting Hook (included with the griddle) to light burners. Access the burners from the front.
- Important: Always use the Lighting Hook (included) when lighting burners with a match.
9. matches illustration (Figure 6).

CAUTION: If burner flame goes out during operation, immediately turn the control knobs to the “ OFF” position, turn the LP gas tank valve to “CLOSED” and open lid to let the gas clear for 5 minutes before relighting.

Figure 6

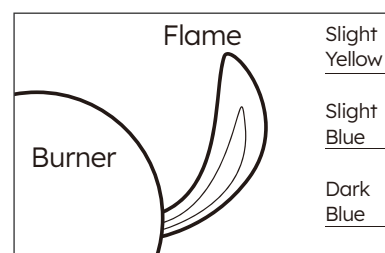

Turning Off

1. Turn LP gas tank valve to “CLOSED”.
2. Turn all control knobs clockwise to the “ OFF” position (Figure 2) Note: A “poof” sound is normal as the last of the LP gas is burned.
3. Disconnect LP gas tank per “Disconnecting LP Gas Tank” section.
4. Season your griddle per “Seasoning Griddle” section.

Controlling Flare-ups

CAUTION:

1. If a grease fire develops, turn control knobs to the “ OFF” position and LP gas tank valve to “CLOSED.” Do NOT use water on a grease fire. This can cause the grease to splatter and could result in serious burns, bodily harm or other damage.
2. Do NOT leave griddle unattended while preheating or burning off food residue on 🔥 or 🔥🔥 (HIGH) If griddle has not been cleaned, a grease fire can occur.

⚠️ **WARNING:** When cooking, fire extinguishing materials should be readily accessible. In the event of an oil/grease fire, use type BC dry chemical fire extinguisher or smother with dirt, sand or baking soda. Do NOT attempt to extinguish with water.

Flare-ups are a part of cooking meats on a griddle and add to the unique flavor of grilling. Excessive flare-ups can over-cook your food and be dangerous. Important: Excessive flare-ups result from the build-up of grease in the grease cup. If a grease fire occurs, turn the control knob(s) to “ OFF” until the grease burns out. If excessive flare-ups occur, do NOT pour water onto the flames.

Minimize Flare-ups:

1. Trim excess fat from meats prior to cooking.
2. Cook high fat content meats on 🔥 (LOW) setting or indirectly.
3. Ensure that your griddle is on a hard, level, non-combustible surface and the grease is allowed to drain into grease receptacle.

Cleaning and Care

- ⚠️ **CAUTION:**
1. All cleaning and maintenance should be done when griddle is cool and with the fuel supply disconnected.
 2. Do NOT clean any griddle part in a self-cleaning oven. The extreme heat will damage the finish.
 3. Do NOT enlarge valve orifices or burner ports when cleaning the valves or burners.

Notices

1. This griddle should be thoroughly cleaned and inspected on a regular basis.
2. Abrasive cleaners will damage this product.
3. Never use oven cleaner to clean any part of griddle.

Before Each Use:

1. Keep the griddle area clean and free from any combustible materials, gasoline, and other flammable vapors and liquids.
2. Do NOT obstruct the flow of the combustion of LP gas and the ventilation of air.
3. Keep the ventilation opening(s) of the LP gas tank area free and clear from debris.
4. Visually check the burner flames to make sure your griddle is working properly (Figure 11).
5. See sections below for proper cleaning and seasoning instructions.
6. Check for obstructions of airflow to the burners. Spiders, insects and webs can clog the burner/venturi tube. A clogged burner tube can lead to a fire.

CLEANING AND CARE (CONTINUED)

Cleaning Cart Surfaces

1. Wipe surfaces clean with mild dish washing detergent or baking soda mixed with water.
2. For stubborn surfaces, use a citrus-based degreaser and a nylon scrubbing brush.
3. Rinse clean with water.
4. Allow to air dry.

Cleaning Main Burners

⚠ **CAUTION: Two (2) people will be required to remove griddle.**

1. Turn LP gas tank valve to "CLOSED".
2. Turn all control knobs clockwise to the "OFF" position. Note: A "poof" sound is normal as the last of the gas is burned.
3. Disconnect LP gas tank per "Disconnecting LP Gas Tank" section.
4. Remove griddle by lifting it off the cart.
5. Remove burners by removing the fasteners, which secure the burners to the frame bottom.
6. Lift burners up and away from gas valve orifice.
7. Disconnect wire from spark electrode.
8. Clean venturi of each burner with small bottle brush or compressed air.
9. Remove all residue and dirt from burner surface.
10. Clean any clogged ports with a stiff wire (such as an opened paper clip).
11. Inspect burners for any damage (cracks or holes). If damage is found, replace with new burner(s) from manufacturer.
12. Re-install burner(s) checking to insure that gas valve orifice is correctly positioned inside each burner/venturi tube. Also, check position of spark electrode.
13. Connect wire to spark electrode.
14. Replace griddle.
15. Connect LP gas tank per "Installing LP Gas Tank" section.
16. Perform leak test per "Checking for Leaks" section.

Before Storing

1. Turn LP gas tank valve to "CLOSED".
2. Turn all control knobs clockwise to the "OFF" position. Note: A "poof" sound is normal as the last of the gas is burned.
3. Disconnect LP gas tank per "Disconnecting LP Gas Tank" section.
4. Clean all surfaces.
5. Lightly coat the burner(s) with cooking oil to prevent excess rusting.
6. Season your griddle per "Seasoning Griddle" section.
7. If storing the griddle indoors, disconnect the LP tank per "Disconnecting LP Gas Tank" section.
8. Place the protective cap cover on the LP tank and store the tank outdoors in a well ventilated area out of direct sunlight.
9. If storing the griddle indoors, cover the griddle and store in a cool dry place.
10. If storing the griddle outdoors, cover the griddle with a griddle cover for protection from the weather.

Seasoning Griddle

Important: season your griddle every time you use it.

Griddle chefs at Japanese steakhouses and short-order restaurants season their griddles all the time, and it is critical for you to do it too. Seasoning helps prolong the life of your griddle, makes the cooking surface non-stick and helps prevent rust. For more information, please visit lumbregrill.com/LumbregrillFAQ.

Tools needed for seasoning:

- Metal scraper or metal spatula
- Cooking oil, such as vegetable oil or extra virgin olive oil
- Paper towels
- BBQ stone or steel wool
- Finishing oil such as flaxseed oil

Figure 7
Burner Flame Conditions
Need to be cleaned

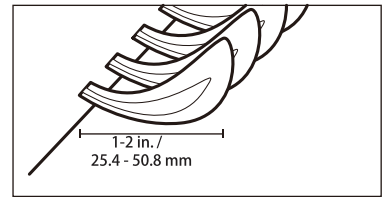

Normal:
Tips Between 1 in-2 in height

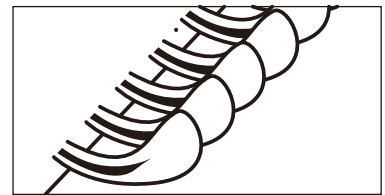

Needs cleaning: Noisy with hard
Blue flames

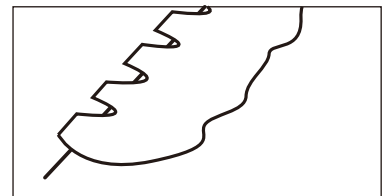

Has to be replaced: wavy with
yellow flames

CLEANING AND CARE (CONTINUED)

⚠ CAUTION: Do NOT use corn oil as it contains a high level of sugar, which can caramelize and burn onto the surface.

First Use

1. Light griddle per “Lighting” section.
2. Keep burners on 🔥 and 🔥🔥 (HIGH) for 15 minutes.
3. Turn griddle off per “Turning Off” section.
4. Allow griddle to cool, but still be slightly warm.
5. Wipe off griddle surface, inner and outer walls with paper towels until clean (HIGH) for 15 minutes.
Note: While drying you may notice the towel may have some discoloration This is normal.
6. Apply finishing oil onto griddle surface, inner and outer walls and evenly coat with rolled up paper towels.
7. Repeat this process at least twice.

After Each Use

1. Turn griddle off per “Turning Off” section.
2. While the griddle is still warm, gently scrape off all food residue with a scraper.
3. Wipe down griddle surface, inner and outer walls with a towel or paper towels.
4. For stubborn food residue:
 - a. Light griddle per “Lighting” section.
 - b. Apply cooking oil onto griddle surface.
 - c. Allow oil to “boil” food residue off.
 - d. Repeat steps 1 through 3.
 - e. If necessary, use a BBQ stone and scrub the food residue off.
 - f. Continue with “Seasoning Griddle” instructions.
5. Wipe off griddle surface, inner and outer walls with paper towels until clean.
Note: While drying you may notice the towel has some discoloration This is normal.
6. Apply finishing oil onto griddle surface, inner and outer walls and evenly coat with rolled up paper towels.
7. Light griddle per “Lighting” section. Keep burners on and .
8. (HIGH) for 15 minutes or until finishing oil starts to smoke.
9. Turn griddle off per “Turning Off” section.
- 10 Repeat steps 6-9 a minimum of 2 additional times.
- 11 Following “Before Storing” section.

Refurbish the Griddle Surface

1. If griddle is off, light per “Lighting” section for 10 minutes Then turn griddle off per “Turning Off” section.
2. If griddle is on, turn griddle off per “Turning Off” section.
3. While the griddle is still warm, use a scraper or metal spatula to remove as much rust and food residue as you can from . the griddle surface, inner and outer walls.
4. Apply a liberal amount of cooking oil onto the griddle surface.
5. Using a BBQ stone, scrub the griddle surface Apply additional cooking oil as need.
6. Wipe off griddle surface, inner and outer walls with paper towels.
7. Repeat steps 3-5 until paper towels no longer show any rust.
8. Apply finishing oil onto griddle surface, inner and outer walls and evenly coat with rolled up paper towels.
9. Light griddle per “Lighting” section.
10. Keep burners on 🔥 and 🔥🔥 (HIGH) for 15 minutes or until finishing oil starts to smoke .
11. Turn griddle off per “Turning Off” section.
12. Repeat steps 7-10 until the surface has a nice dark color (HIGH) for 15 minutes or until finishing oil starts to smoke.
13. Following “Before Storing” section.

TROUBLESHOOTING

Burner will not light using igniter	LP gas tank valve is closed	Make sure regulator is securely attached to the LP gas tank per "Installing LP Gas Tank," then turn LP gas tank valve to "OPEN"
	LP gas tank is low or empty	Exchange, refill or replace LP gas tank
	LP gas	1.Turn LP gas tank valve to "CLOSED" 2.Wait 5 minutes for gas to clear 3.Follow "Checking for Leaks" section
	Wires or electrode covered with cooking residue	Clean wire and/or electrode with rubbing alcohol
	Electrode and burners are wet	Wipe dry with cloth
	Electrode cracked/broken - sparks at crack	Replacement part(s) may be needed - contact at Service@thebestfire.
	Wire loose or disconnected	com Reconnect wire or replacement part(s) may be needed - contact Customer Care at Service@thebestfire.com
	Wire is shorting (sparking) between igniter and electrode	Replacement part(s) may be needed - contact at Service@thebestfire.com
Burner will not light with match	Bad igniter	Replacement part(s) may be needed - contact at Service@thebestfire.com
	No gas flow	Check if LP gas tank is empty A If empty, exchange, refill or replace LP gas tank B If LP gas tank is not empty, refer to "Sudden drop in gas flow or reduced flame height" (see below)
	LP gas tank is low or empty	Exchange, refill or replace LP gas tank
	LP gas	1.Turn LP gas tank valve to "CLOSED" 2.Wait 5 minutes for gas to clear 3.Follow "Checking for Leaks" section
	Coupling nut and regulator not fully connected	Turn the coupling nut about one-half to three-quarters additional turn until solid stop Tighten by hand only - do NOT use tools
	Obstruction of gas flow	1.Clear burner/venturi tube 2.Check for bent or kinked hose
	Disengagement of burner to valve	Re-engage burner and valve
	Spider webs or insect nest in venturi	Clean burner/venturi tube
Sudden drop in gas flow or reduced flame height	Burner ports clogged or blocked	Clean burner ports
	Out of gas	Exchange, refill or replace LP gas tank
Sudden drop in gas flow or reduced flame height	Overfilling prevention device may have been activated	1.Turn control knobs to " OFF" 2.Wait 30 seconds and light griddle 3.If flames are still too low, reset the overfilling prevention device: a.Turn control knob(s) " OFF" b. Turn LP gas tank valve to "CLOSED" c. Disconnect regulator d. Turn control knobs to 🔻 and 🔻🔻 (High) e. Wait 1 minute f. Turn control knobs to " OFF" g. Reconnect regulator and leak check connections, being careful not to fully open valve h. Light griddle per "Lighting" section
	Out of gas	Exchange, refill or replace LP gas tank
Irregular flame pattern, flame does not run the full length of burner	Burner ports are clogged or blocked	Clean burner ports
Flame is yellow or orange	New burner may have residual manufacturing oils	Burn griddle for 15 minutes on 🔻 and 🔻🔻 (HIGH) with the lid closed
	Spider webs or insect nest in venturi	Clean venturi
	Food residue, grease, etc on burners	Clean burner
	Poor alignment of valve to burner/venturi tube	Ensure burner/venturi tube is properly engaged with valve
Flame goes out	High or gusting winds	Do not use griddle in high winds
	Low on LP Gas	Exchange, refill or replace LP gas tank
	Overfilling prevention device may have been activated	Refer to "Sudden drop in gas flow or reduced flame height" (see above)
Flare-up	Grease buildup	Remove and clean all griddle parts per "Cleaning and Care" section
	Excess fat in meat	Trim fat from meat before cooking
	Excessive cooking temperature	Adjust to lower cooking temperature
Persistent grease fire	Grease trapped by food buildup around burner system	1.Turn control knobs to " OFF" 2.Turn LP gas tank valve to "CLOSED" 3.Leave lid in closed position and let fire burn out 4.After griddle cools, remove and clean all parts per "Cleaning and Care" section
Flashback (fire in burner tube(s))	Burner and/or burner/venturi tube are blocked	Clean burners and/or burner/venturi tube
Griddle Surface	Griddle has started to rust	With use the griddle surface will rust, this is normal Follow the "Refurbish the Griddle Surface" instructions in the "Seasoning Griddle" section to season your griddle surface
	Griddle surface looks dull	The cooking surface has gotten too hot, and is no longer seasoned Season grill per "Seasoning Griddle" section