

MODEL : RDT012 ROUND DINING TABLE

ASSEMBLY INSTRUCTIONS

Read this instruction carefully. See hardware and Furniture part list for guidance.
 Be sure all parts are complete, before you assemble. Pace all wooden prevent from being scratched.
 Follow the figure to start assembling.

CAUTIONS: 1. Do not FULLY- TIGHTEN the nut or bolt until all nut and bolt is ready assembled.
 2. Do not OVER - TIGHTEN the nut or bolt avoid causing damages to the thread.
 3. Keep all hardware parts out of reach of children.

NOTE: THE LIST AND QUANTITY SHOWN ARE FOR 1 UNIT ASSEMBLY.

PART LIST		
ITEM	DESCRIPTION	QTY
A	TABLE TOP SUPPORT	1 PC
B	TABLE LEG	1 PC
C	TABLE TOP	1 PC

HARDWARE LIST		
ITEM	DESCRIPTION	QTY
1	JCBC SCREW M6 x 40mm	4 PCS
2	SPRING WASHER M6	4 PCS
3	FLAT WASHER M6 x 13mm	4 PCS
4	ADJUSTABLE M6 x 23mm	6 PCS
5	CSK SCREW M4 x 25mm	8 PCS
6	ALLEN KEY M4	1 PC

STEP 01

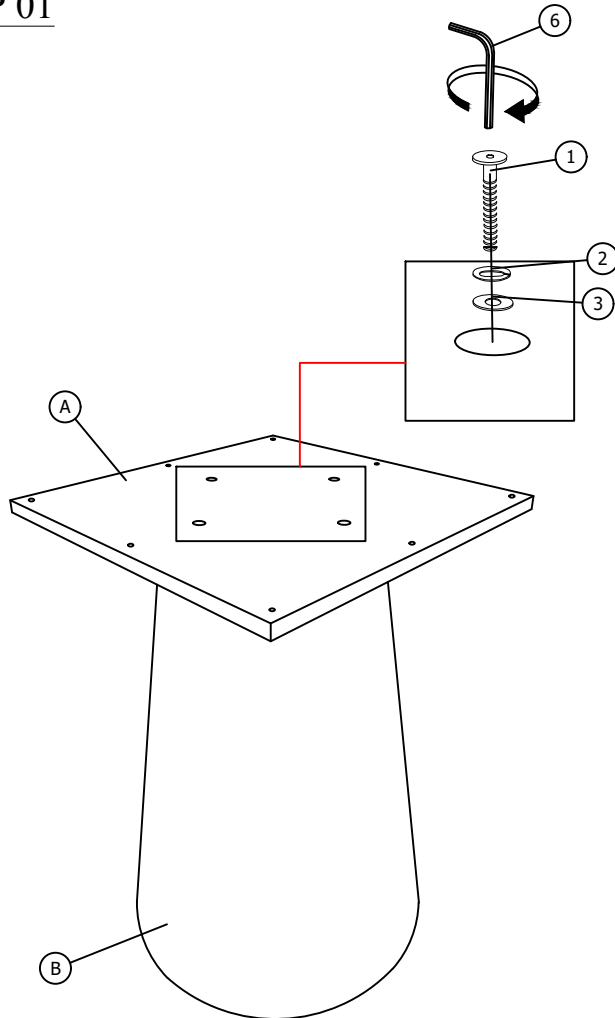

STEP 02

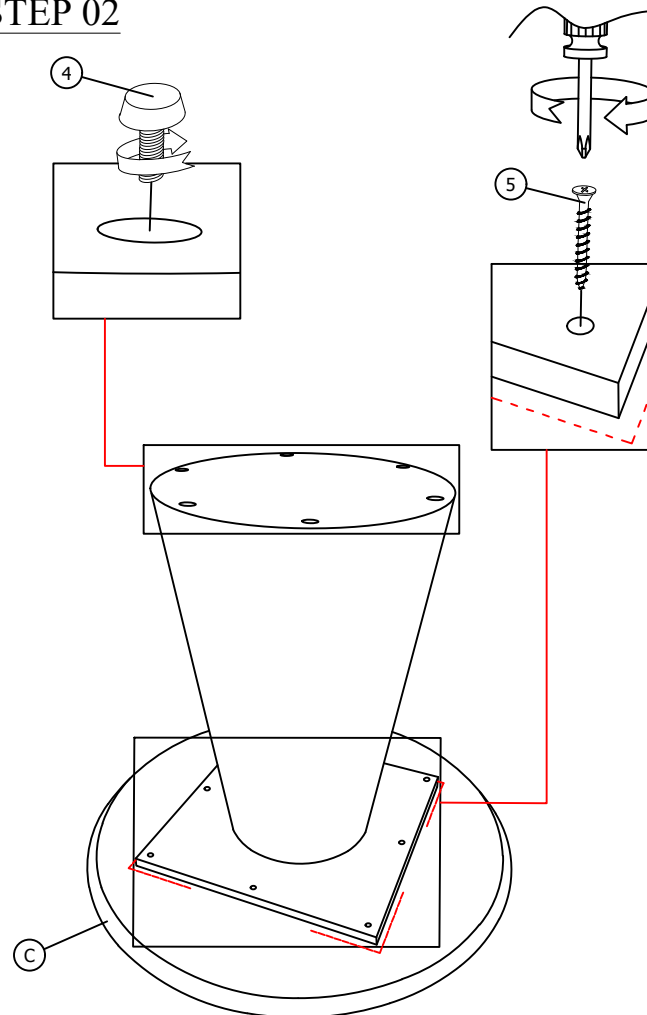

Remark : Place the table top support and table leg followed to the marking on the back table.

STEP 03

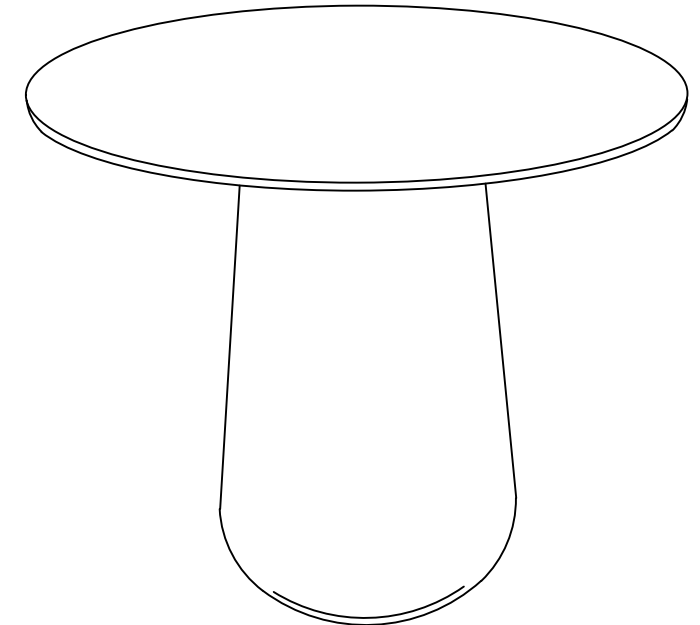

FULLY SET-UP (TABLE)