

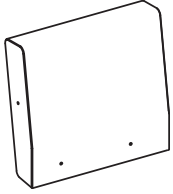

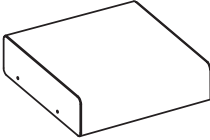

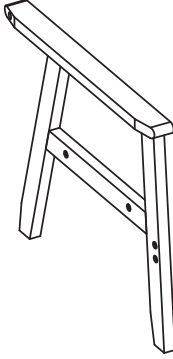

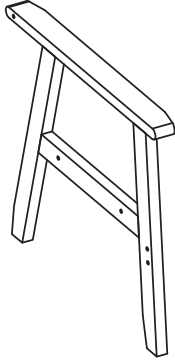

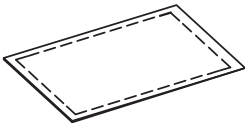



A		x1		B		x1		C		x1		D		x1																	
																															
E		x1		F		x1																									
																															
G		x4		H		x12		I		x4		J		x2		K		x12		L		x4		M		x1		N		x1	
																															



	40MIN		
---	--------------	---	---

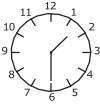

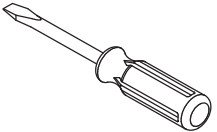
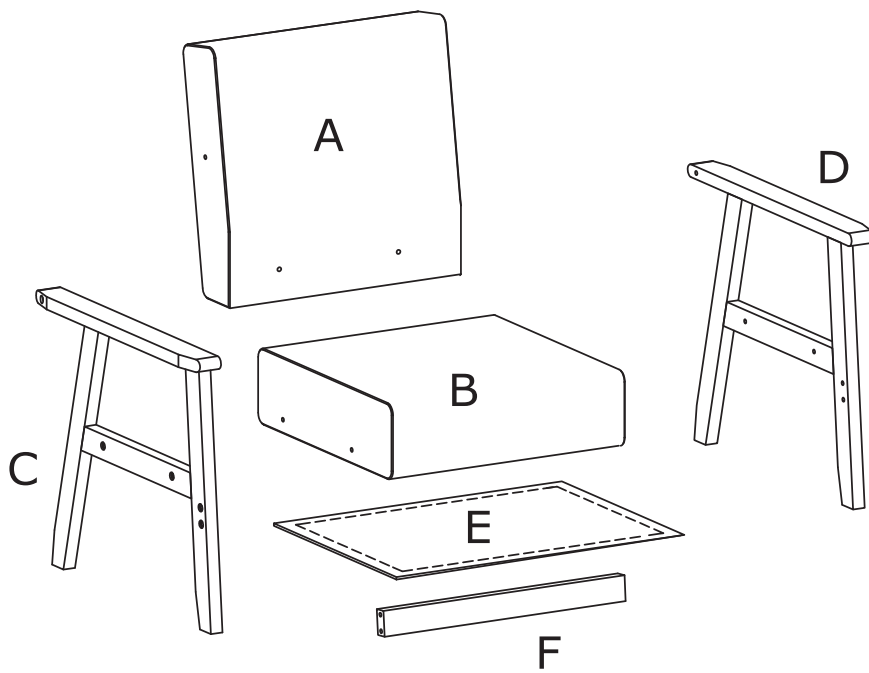
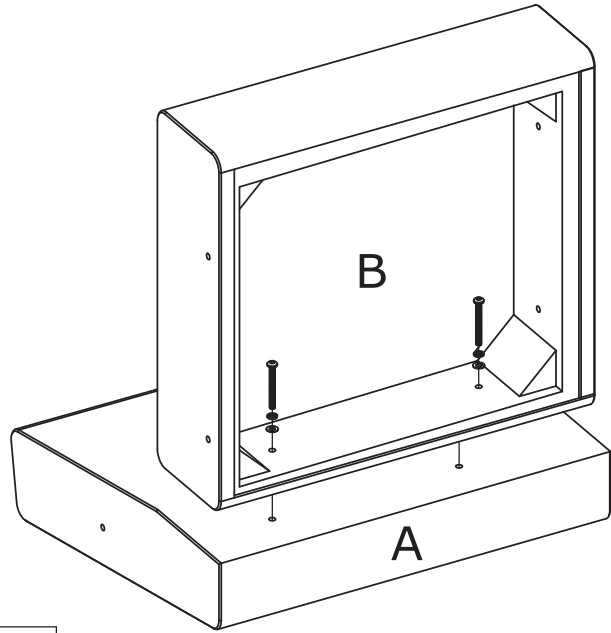
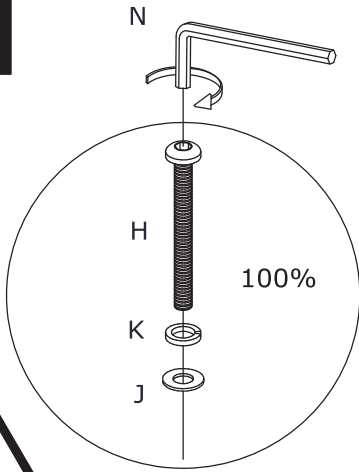
1



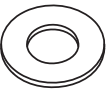

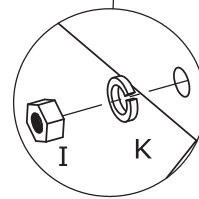
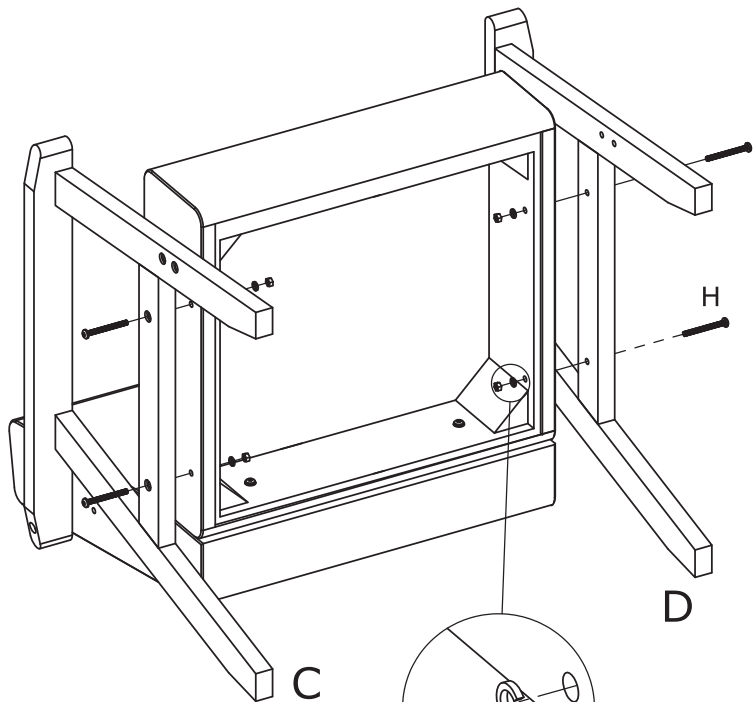
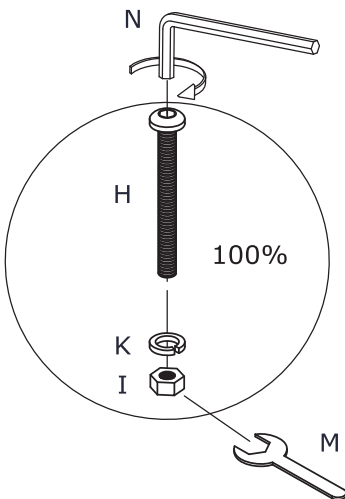

1. Insert 4 sets hardware into position first.
2. Tighten them in the same time then.

H	x2	J	x2	K	x2	N	x1
							



2

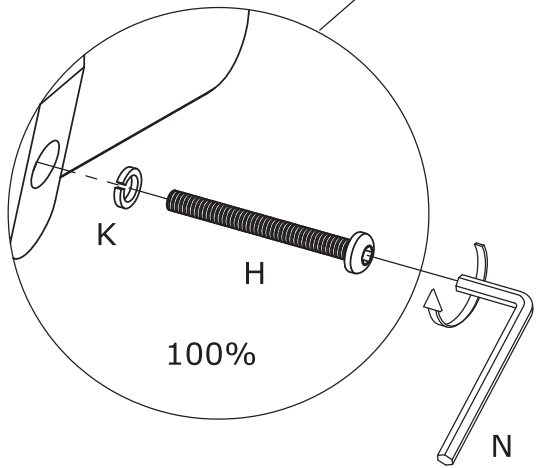
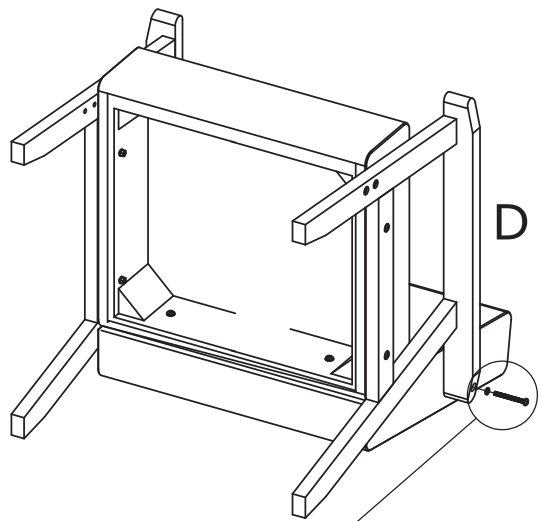
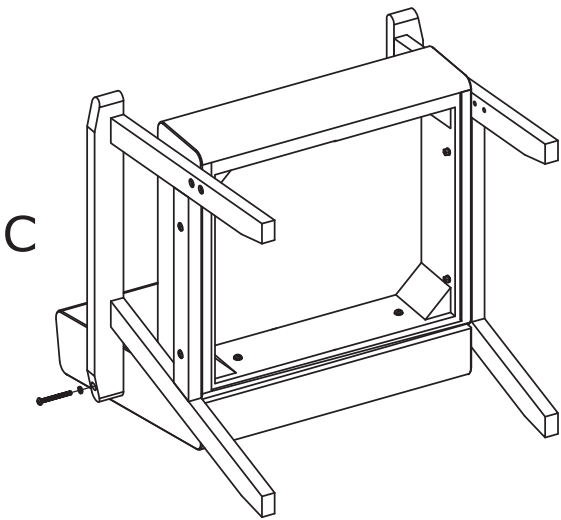

H	x4	K	x4	I	x4	M	x1	N	x1
									

3





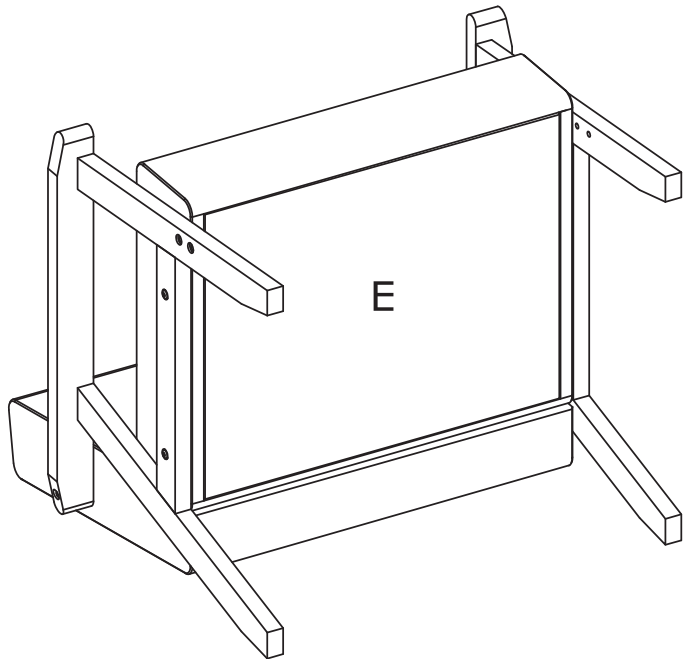

H	x2	K	x2	N	x1
					
M8x60					

4

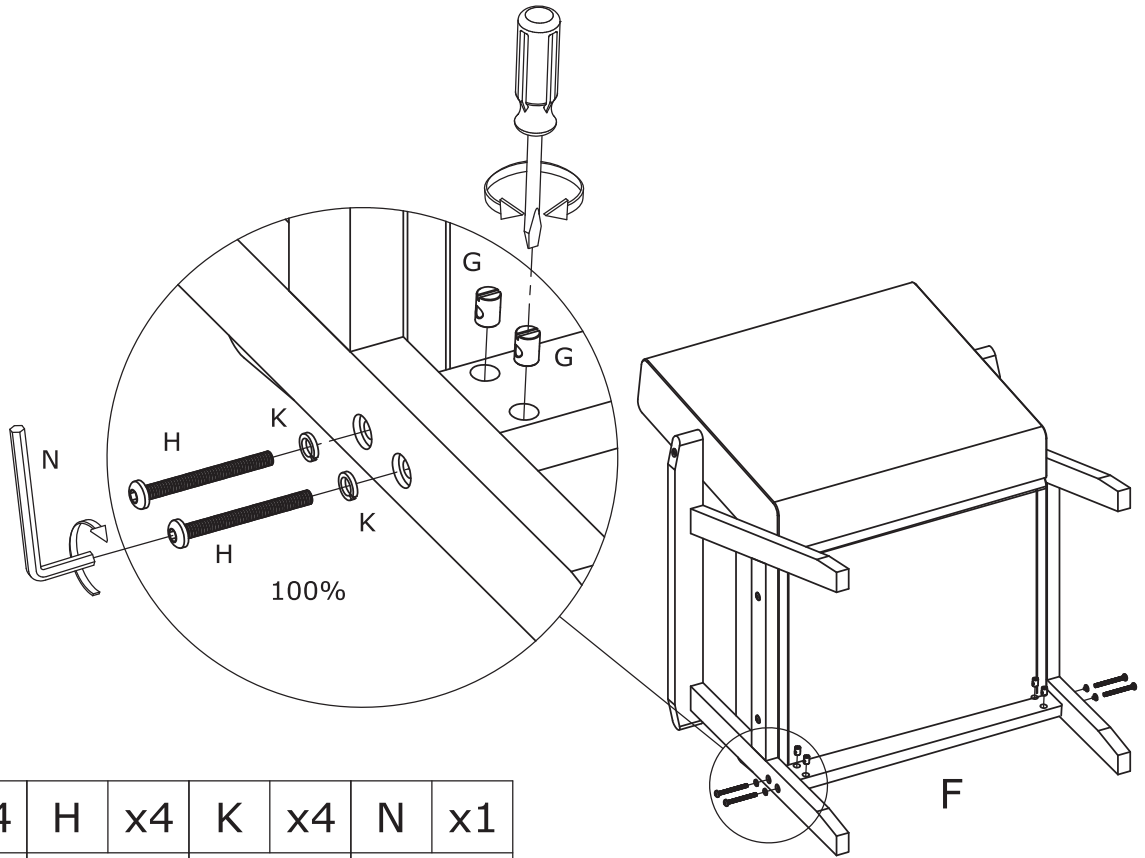



5

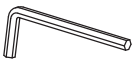

G	x4	H	x4	K	x4	N	x1
							
		M8x60					

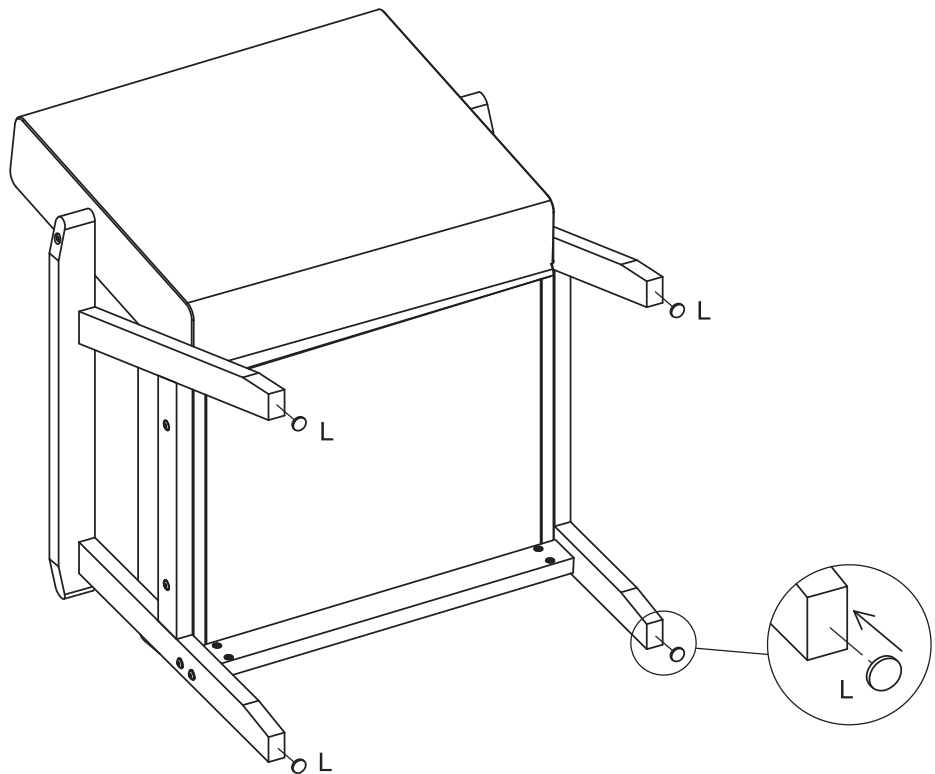

6







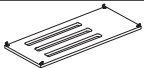

L	x4
	

ASSEMBLY INSTRUCTIONS

PARTS LIST

No.	DESCRIPTION	SKETCH	Q'TY
A	TOP FRAME		1PC
B	SHELF		1PC
C	LEGS		4PCS

HARDWARE LIST

NO.	DESCRIPTION	SKETCH	Q'TY
1	BOLT Ø1/4"x5/8"		4PCS
2	BOLT Ø1/4"x2-1/2"		8PCS
3	LOCK WASHER 1/4 "		12PCS
4	FLAT WASHER 1/4"x16mm		4PCS
5	FLAT WASHER 1/4"x19mm		8PCS
6	WRENCH 4MM		1PC

