

ASSEMBLY INSTRUCTIONS

Congratulations on your purchase – Get ready to be inspired!

Please check to ensure that all parts are included. Contact place of purchase for any service issues. Keep this document for reference in case parts are needed.

INSTRUCTION D'ASSEMBLAGE

Félicitons d'avoir acheté - Apprêtez-vous à être inspirés!

Veillez vous assurer d'avoir toutes les pièces. Nous vous conseillons de contacter l'endroit où vous avez fait votre achat si vous nécessitez un service quelconque. Veuillez conserver ce document à titre de référence si vous avez besoin de pièces.

**** IMPORTANT ****
MUST READ BEFORE ASSEMBLY!

FOR YOUR FURNITURE TO LAST, CORRECT ASSEMBLY AND PROPER MAINTENANCE ARE NECESSARY.
PLEASE FOLLOW THE INFORMATION PROVIDED BELOW TO FULLY ENJOY YOUR FURNITURE.

BASIC ASSEMBLY TECHNIQUES

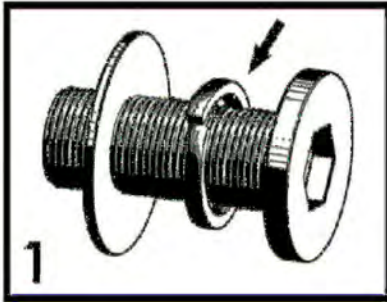

1 Before attaching each of the screws, make sure that the **smaller lock washer is between** the larger washer and the head of the screw.



2 Position each part correctly and insert all screws into their respective holes. Then, **hand-tighten** only until 70% tight. Complete tightening with the tools will come at a later step.

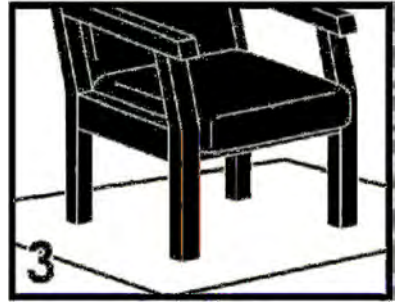

3 Make sure the furniture rests on a **flat and level surface** with each leg evenly touching the ground. Use a soft blanket or carpet underneath when turning the piece on its side.

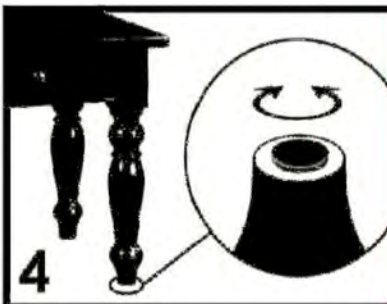

4 Some furniture come with optional **height adjustment knobs** underneath each leg. Turn this knob counterclockwise to raise the leg level or clockwise to lower the leg level.



5 Finally, make sure all parts are properly aligned then use the included **tools** to completely tighten the screws. Your furniture is now ready for use.

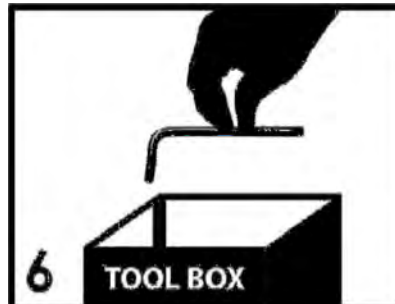

6 Store the **tools** for later maintenance. Tighten the screws again **after two (2) weeks**, and then at least **once every six (6) months** after that.

IT IS THE USER'S RESPONSIBILITY TO MAINTAIN THE FURNITURE. THE SCREWS MAY LOOSEN OVER TIME AND CAUSE THE FURNITURE TO BE WOBBLY AND UNABLE TO SUPPORT ITS INTENDED WEIGHT CAPACITY. THIS CAN LEAD TO COLLAPSE AND CAN CAUSE SERIOUS INJURY.



FAILURE TO FOLLOW THE GUIDELINES ABOVE MAY RESULT IN INJURY AND/OR PROPERTY DAMAGE.

**** IMPORTANT ****
DEVEZ LIRE AVANT ASSEMBLAGE!

POUR QUE VOTRE MEUBLE DURE LONGTEMPS, IL EST IMPORTANT DE L'ASSEMBLER ET DE L'ENTREtenir CORRECTEMENT. POUR PROFITER PLEINEMENT DE VOTRE MEUBLE, VEUILLEZ SUIVRE LES INDICATIONS CI-DESSOUS.

ASSEMBLAGE

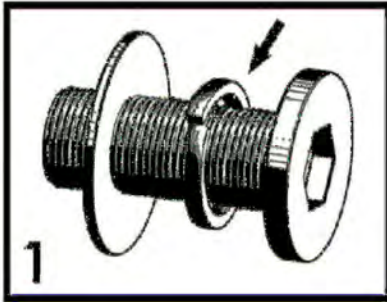

1 Avant de serrer chacune des vis, assurez-vous que la petite rondelle de blocage se trouve en la rondelle



2 Positionnez correctement chacune des vis. Utilisez la main seulement jusqu'à 70%.

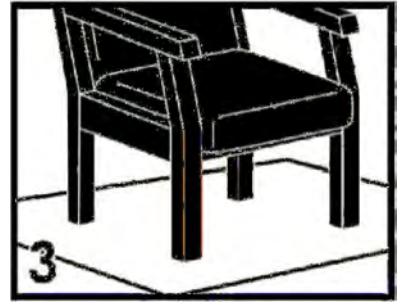

3 Assurez-vous que le meuble repose sur le sol. Utilisez une couverture douce ou un tapis pour protéger le sol.

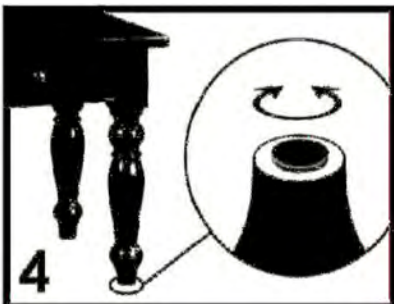

4 Tournez ce bouton vers la gauche pour augmenter le niveau du pied ou dans le sens horaire pour abaisser le niveau du pied.

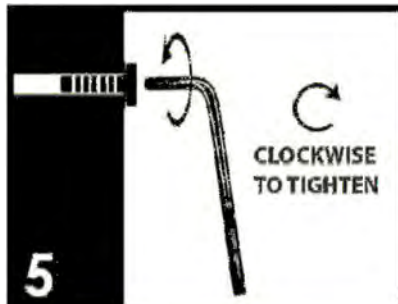

5 Utilisez les outils inclus pour bien serrer toutes les vis. Vous pouvez maintenant utiliser votre meuble.

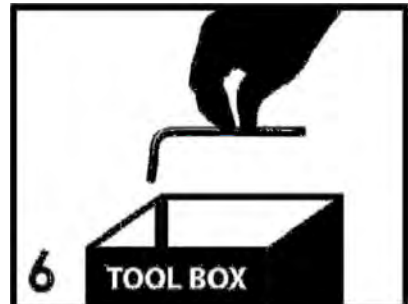

6 Pour effectuer l'entretien de votre meuble, serrez de nouveau les vis; serrez-les ensuite au moins une fois tous les six (6) mois.

L'UTILISATEUR À LA RESPONSABILITÉ DE FAIRE L'ENTREtenir DE SON MEUBLE. AVEC LE TEMPS, LES VIS PEUVENT SE DESSERRER; LE MEUBLE PEUT DEVENIR BANCAL ET NE PAS POUVOIR SUPPORTER SA CHARGE NOMINALE. CETTE SITUATION PEUT CAUSER UNE CHUTE ET DES BLESSURES GRAVES.



LE FAIT DE NE PAS RESPECTER LES CONSIGNES CI-DESSUS PEUT ENTRAÎNER DES BLESSURES OU DES DOMMAGES.

ASSEMBLY INSTRUCTION

Instruction D'Assemblage

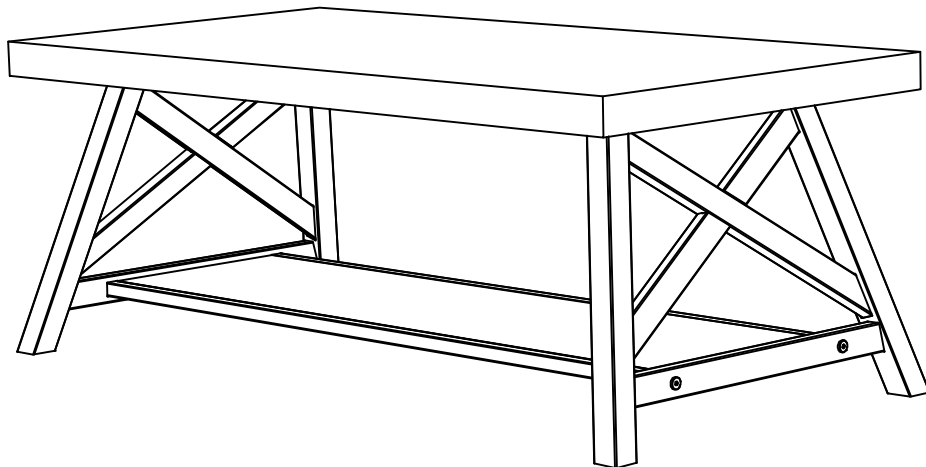

EASY
FACILE



DIFFICULT
DIFFICILE

***2 Persons recommended /
*2 Personnes recommandées**





ASSEMBLY RATING





The Assembly Rating is a 5-point system that shows the degree of effort needed in assembling a specific product (with 1 being easy and 5 being difficult). For some products, two persons are recommended.

DIFFICULTÉ D'ASSEMBLAGE

Le vendeur Assemblée est un système à 5 points qui montre le degré d'effort nécessaire à l'assemblage d'un produit spécifique (1 étant facile et 5 étant relativement difficile). Pour certains produits, deux personnes sont recommandées.

DO NOT TIGHTEN SCREWS UNTIL EACH STEP IS COMPLETED
NE PAS SERRER LES VIS JUSQU'À CE QUE CHAQUE ÉTAPE EST TERMINÉ

PARTS IDENTIFICATION LIST LISTE DES PIÈCES			
NO	DRAWING SHAPE	DESCRIPTION DESCRIPTION	QTY QTÉ
#1		Top Panel	1PC
#2		Lower Panel	1PC
#3		Side Frames	2PCS
#4		Upper Cross Bars	2PCS
#5		Lower Cross Bars	2PCS

HARDWARE LIST LISTE DE QUINCAILLERIE			
NO	DRAWING SHAPE	DESCRIPTION DESCRIPTION	QTY QTÉ
#A		Bolt 1/4" x 2" Boulon ϕ 1/4" x 2"	2PCS
#B		Bolt 1/4" x 1-1/4" Boulon ϕ 1/4" x 1-1/4"	6PCS
#C		Bolt ϕ 1/4" x 1/2" Boulon ϕ 1/4" x 1/2"	22PCS
#D		Allen Wrench 4mm Clé Allen 4mm	1PC

STEP 1
ÉTAPE 1

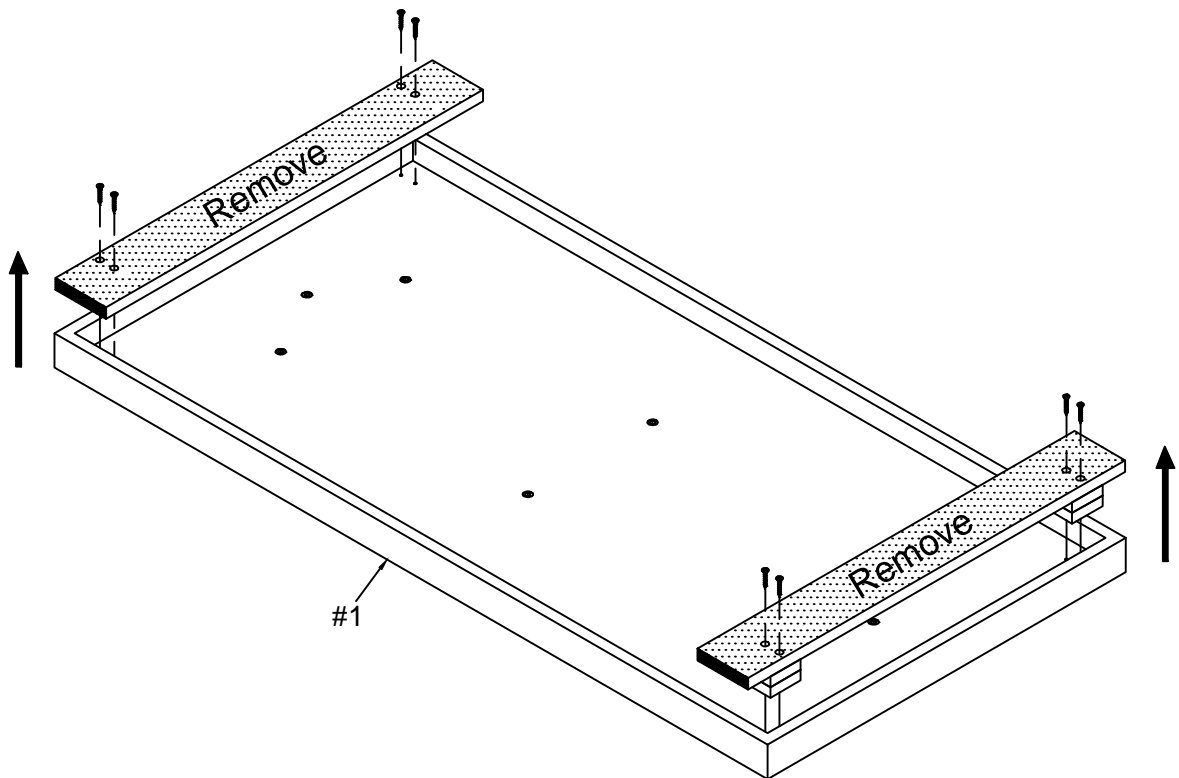

**Do not tighten screws until completely assembled.
Ne serrez pas vis jusqu'à qui entièrement assemblé**

STEP 2
ÉTAPE 2

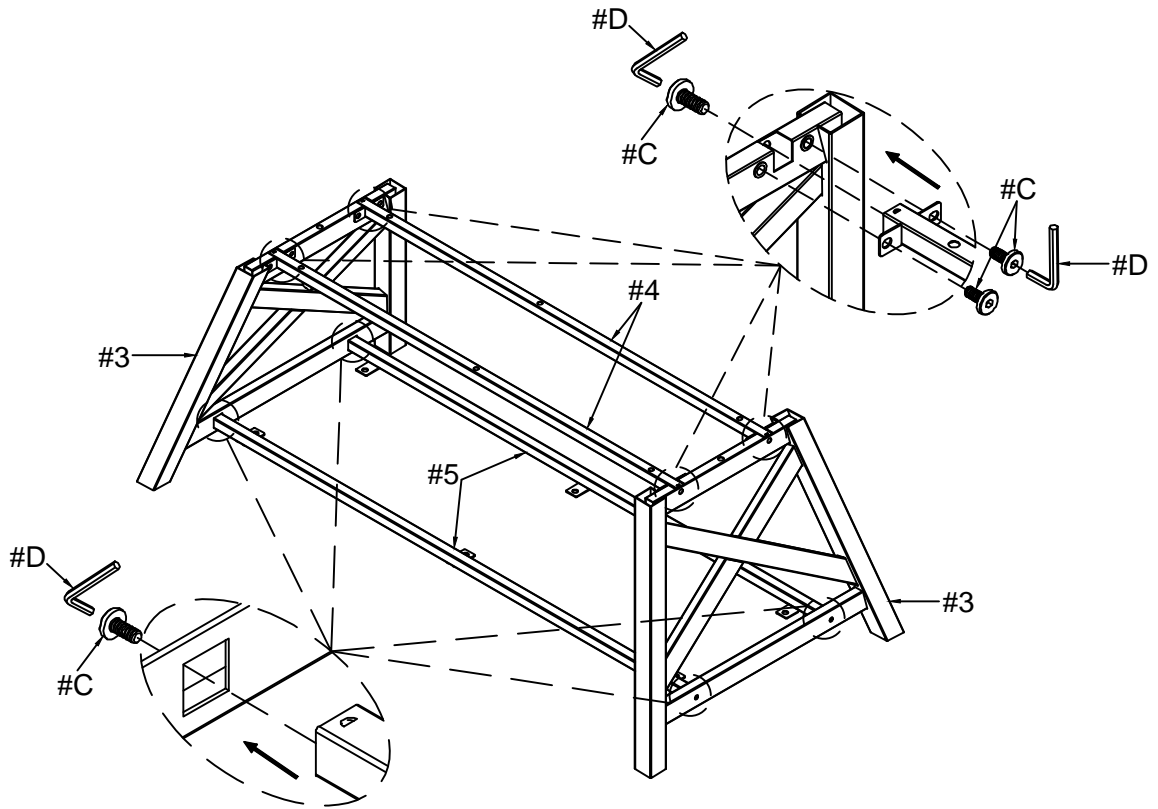

STEP 3
ÉTAPE 3

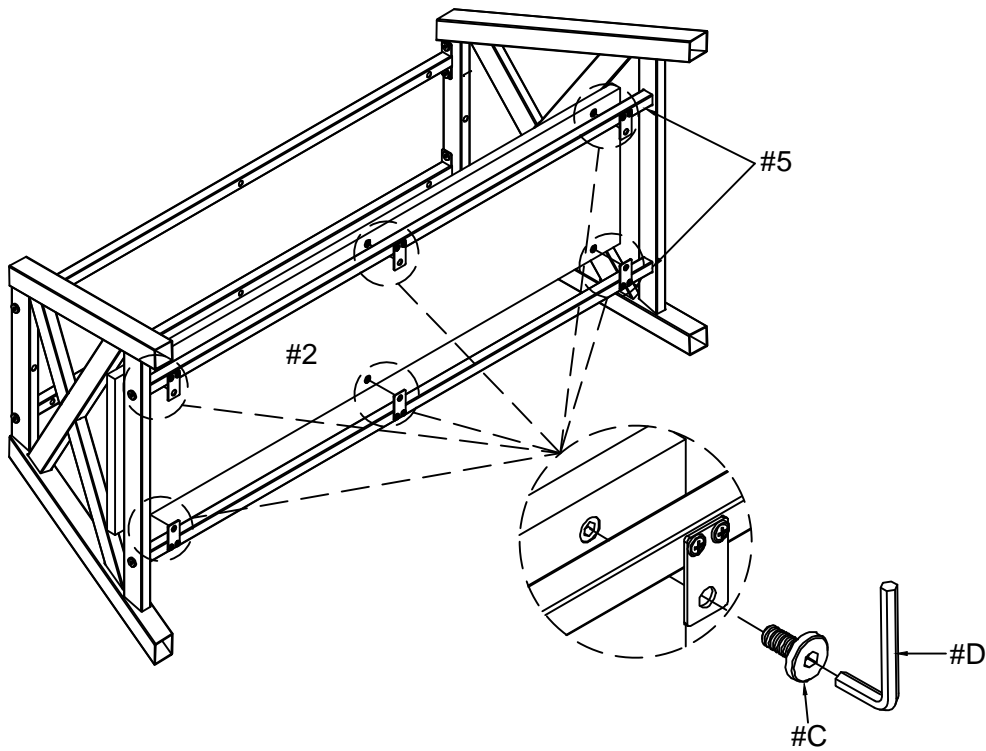

**Do not tighten screws until completely assembled.
Ne serrez pas vis jusqu'à qui entièrement assemblé**

STEP 4
ÉTAPE 4

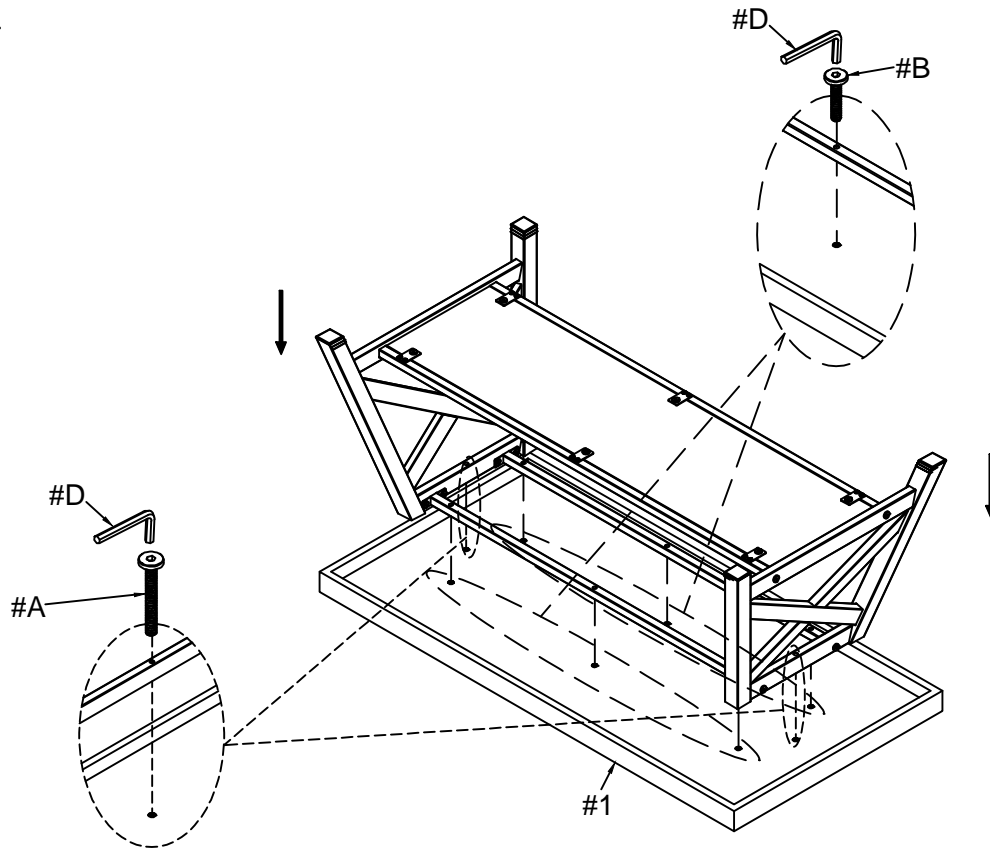

STEP 5
ÉTAPE 5

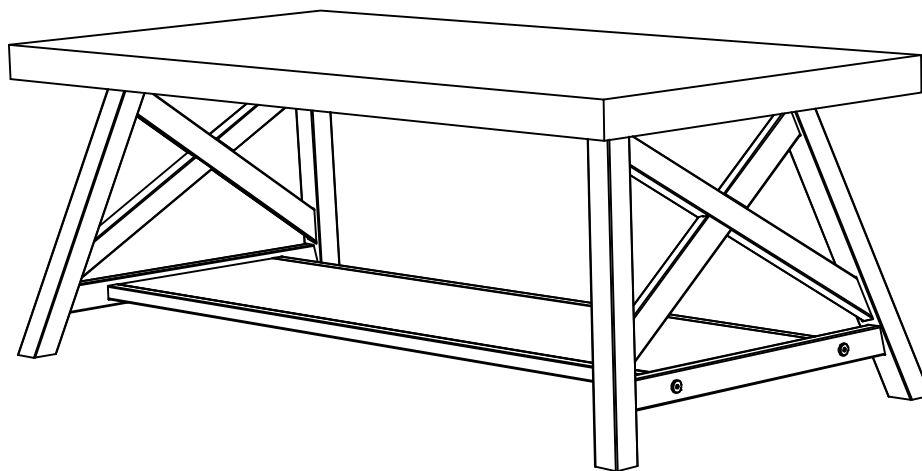

**Do not tighten screws until completely assembled.
Ne serrez pas vis jusqu'à qui entièrement assemblé**