

ASSEMBLY INSTRUCTION

Coffee Table

Item NO.: ECT170101、ECT170102、ECT170103、
ECT170104、ECT170105、ECT170106

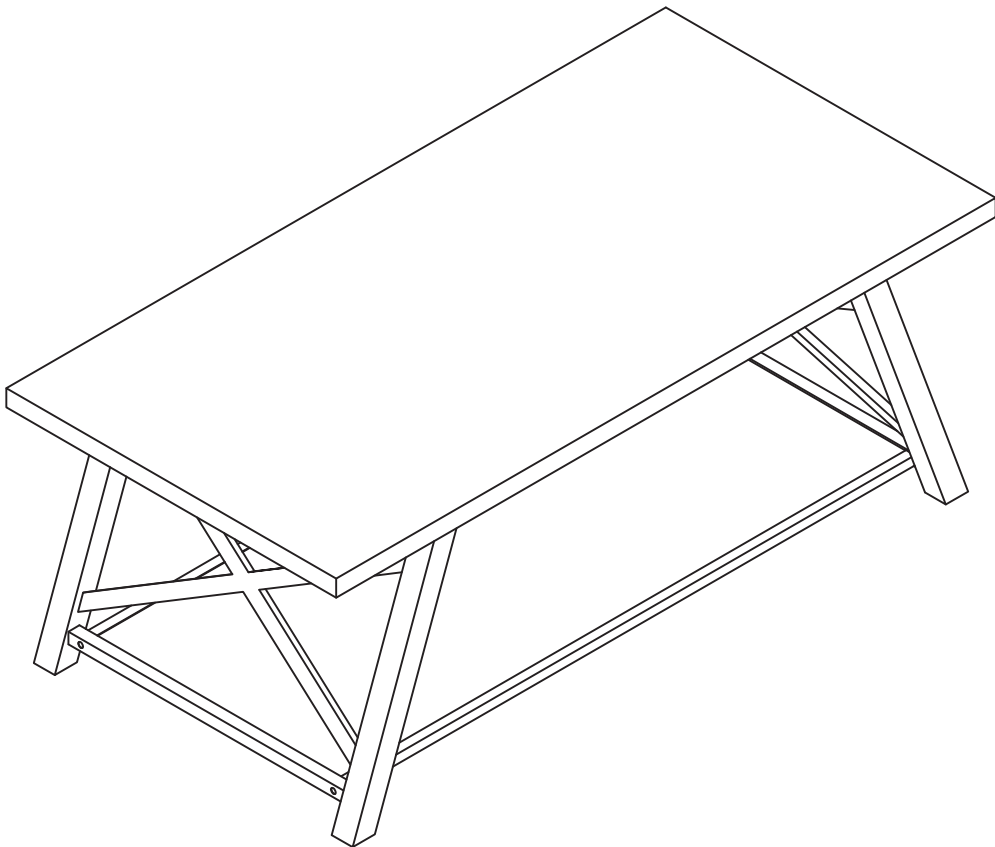

EXCEFUR FURNITURE

Part Identification

While not all parts are labeled, some of the parts will have a label to help distinguish similar parts from each other. Use this part identification to help identify similar parts.

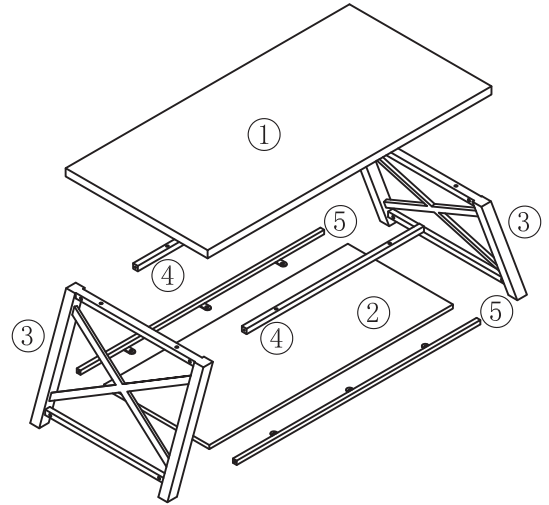
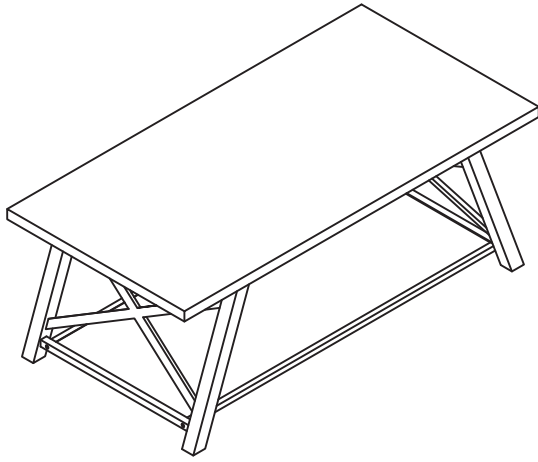

①

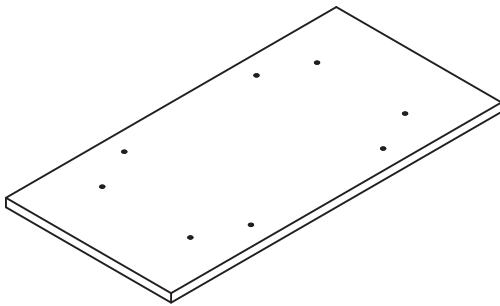

Top Shelf 1 pc

②

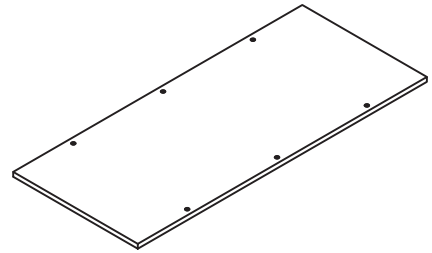

Bottom Shelf 1 pc

③

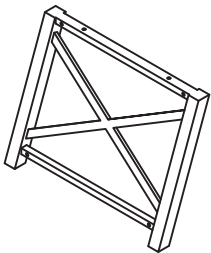

Metal Frame 2 pcs

④

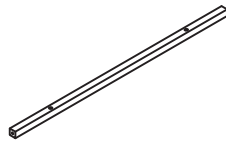

Metal Rod 2 pcs

⑤

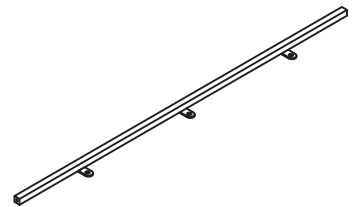

Metal Tube 2 pcs

A

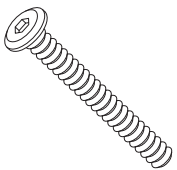

**Long Bolt
M6*50mm 8 pcs**

B



**Medium Bolt
M6*35mm 8 pcs**

C



**Short Bolt
M6*12mm 6 pcs**

D

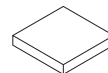

**Anti-skid Pad
30*30*5mm 4 pcs**

E

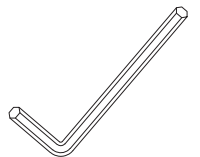

**Allen Key
4mm 1pc**

Step 01

NOTE: DO NOT fully tighten all bolts at this step.
Product support email: alan@excefur.com

- 1.1 Place two Metal Frames(3) on a clean smooth surface such as carpet or cardboard. Attach and align two Metal Rods(4) to Metal Frames(3) with four Long Bolts(A) by Allen Key(E).
- 1.2 Attach Metal Frames(3) and Metal Rods(4) to Top Shelf(1) with eight Medium Bolts(B) by Allen key(E).
- 1.3 Stick four anti-skid pads(D) onto the bottom of table legs.

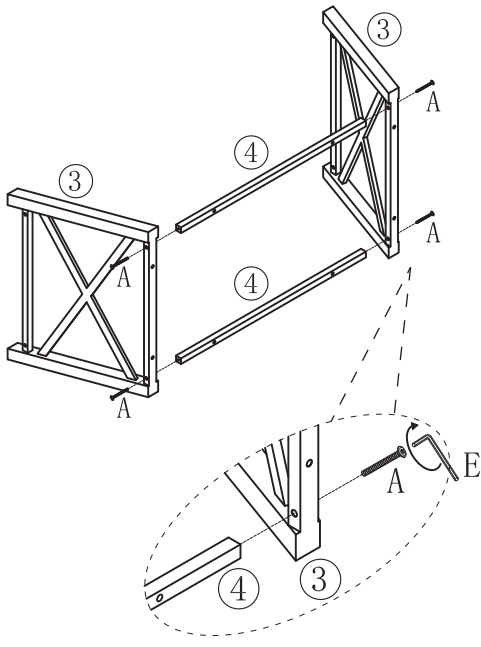

1.1

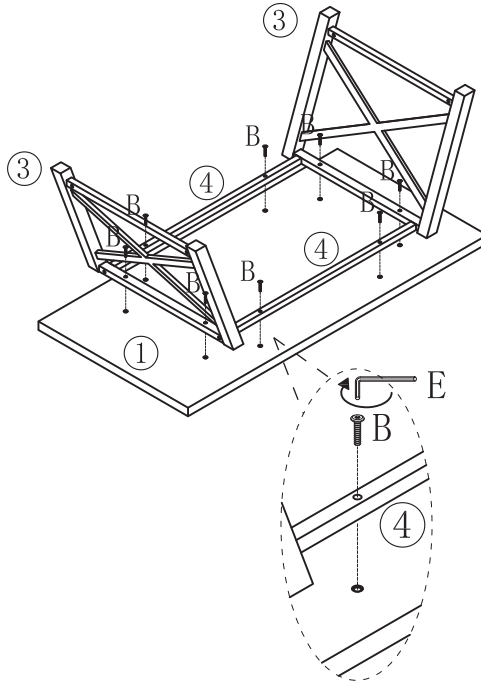

1.2

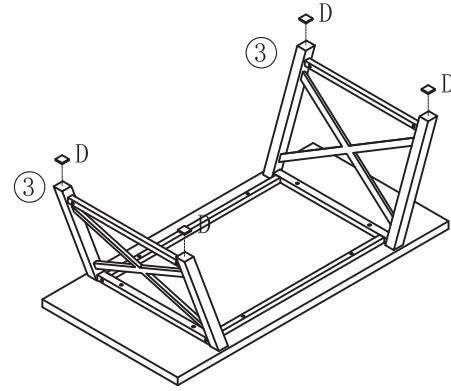

1.3

Step 02

NOTE: If holes don't align, loosen all bolts and adjust the holes slightly. After all holes are aligned, tighten all bolts.

- 2.1 Connect and fasten two Metal Tubes(5) to Bottom Shelf(2) with six Short Bolts(C) by Allen key(E).
Note: Ensure that the Metal Tubes(5) are flush with the Bottom Shelf(2). Then, Fully tighten all bolts after all holes are aligned.
- 2.2 Attach and align the Bottom Shelf(2) to the Metal Frames(3) with four Long Bolts(A) by Allen key(E).
If holes don't align, loosen all bolts and adjust the holes slightly. After all holes are aligned, tighten all bolts.
- 2.3 Turn the table upright to complete the assembly.

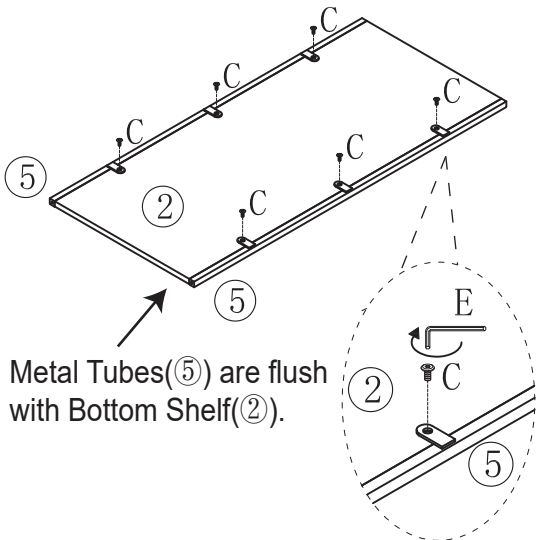

2.1

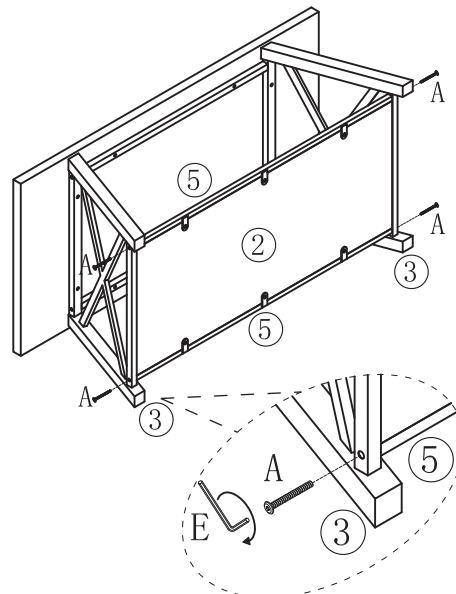

2.2

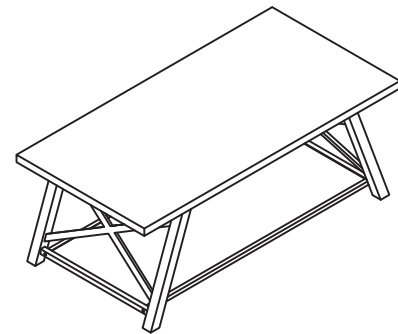

2.3



Thank you for purchasing EXCEFUR Coffee Table. If any part is missing or damaged, please do not hesitate to contact us, we will send you the replacement immediately.

Email: alan@excefur.com

ASSEMBLY TIPS

1. Please read the assembly instructions first and become familiar with the parts.
2. Proper assembly of this item requires 2 people.

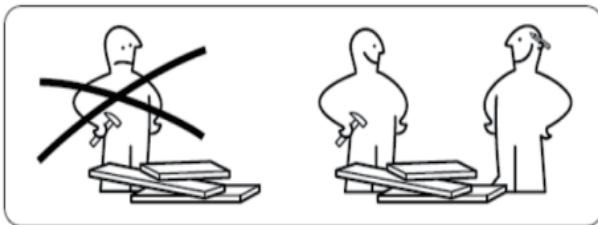

3. Unpack and assemble this unit in an spacious area, assemble the unit on top of the empty carton or carpet to prevent scratches.

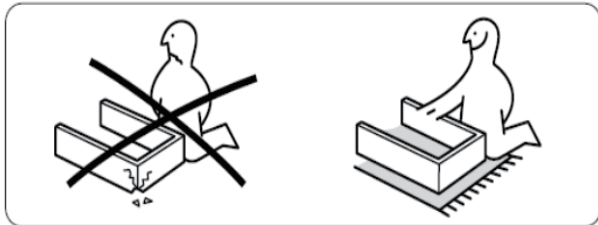

4. To avoid accidentally discarding small parts or hardware, **DO NOT** dispose of any contents until assembly is completed.
5. **Do not fully tighten all bolts until all parts are in place.** Failure to follow these instructions may cause the bolts to misalign during assembly.

CARE INSTRUCTIONS

- (1) Hardware may loosen overtime. Periodically check that all connections are tight.
- (2) Wipe with a soft, dry cloth. To protect finish, avoid the use of chemicals and household cleaners.
- (3) All hot serving dishes should be placed on a pad.
- (4) Any liquid spilled onto the furniture should be cleaned up immediately with a dry cloth.