

Assembly instructions

Instructions d'assemblage

We're here to help - Do not return this product !

Call, email or find us online first !

- If you need help with assembly
- If you received a damaged or defective part
- If you are missing hardware

We will process replacement parts in 3-5 business days or less. Parts are shipped via FedEx Ground or mail.

Nous sommes là pour vous - Ne retournez pas ce produit !

Appelez, écrivez ou trouvez-nous en ligne d'abord !

- Si vous avez besoin d'aide avec l'assemblage
- Si vous avez une pièce manquante ou endommagée
- S'il vous manque de la quincaillerie

Nous vous enverrons les pièces de rechange dans un délai de 3 à 5 jours ouvrables, ou moins. Les pièces sont expédiées via FedEx Ground ou par la poste.

Online resources

Ressources disponibles en ligne

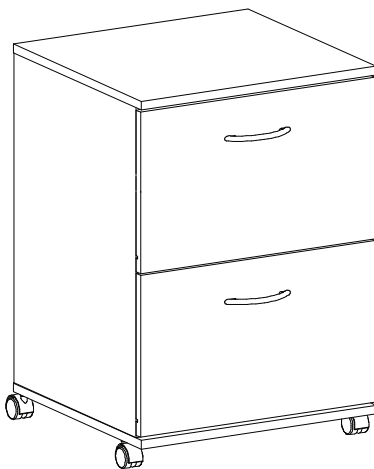

Weight capacity : 25 lb per drawer
Capacité par tiroir : 25 lb

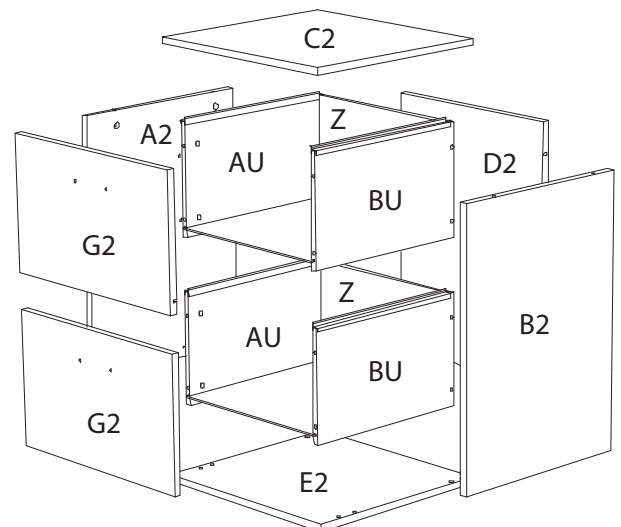

How-to videos
Vidéos d'aide



Read these assembly instructions carefully before beginning. Verify that you have in hands all the wood parts and hardware. Keep this document for future reference.

Lisez attentivement ce guide d'assemblage avant de débiter. Assurez vous que toutes les composantes de bois et de quincaillerie sont présentes. Conservez ce document.

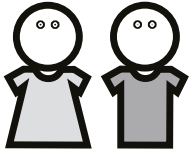

Two people are required to assemble and move this unit.
Deux personnes sont requises pour assembler et déplacer ce meuble.



Safety First! Do not allow children to climb on or play with furniture.
Attention! Ne permettez pas aux enfants de jouer ou grimper sur les meubles.

Never leave liquids or damp clothes on your furniture. Never use chemical product to clean your furniture. Do not place your furniture in direct sunlight.

To clean your furniture, dampen a soft cloth with a mild solution of dishwashing liquid. Squeeze excess water. Clean unit and wipe it dry.



Ne jamais laisser de liquide ou de linge humide sur votre meuble. Ne jamais utiliser de produits chimiques pour nettoyer votre meuble. N'exposez pas votre meuble à la lumière directe du soleil.

Pour nettoyer votre meuble, trempez un chiffon doux dans une faible solution de liquide pour la vaisselle et d'eau. Bien essorer. Nettoyez le meuble et essuyez soigneusement le surplus d'eau avec un linge sec.

Tools required
Outils requis

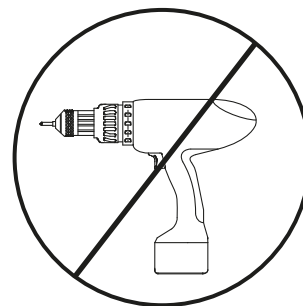
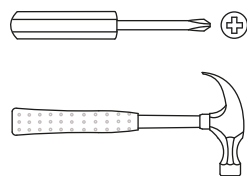









How-to videos
Vidéos d'aide

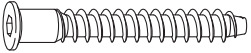

Hardware List

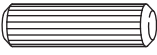
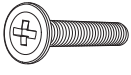
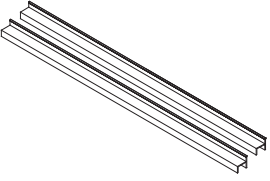
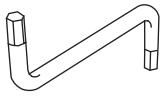
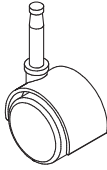
Liste de Quincaillerie

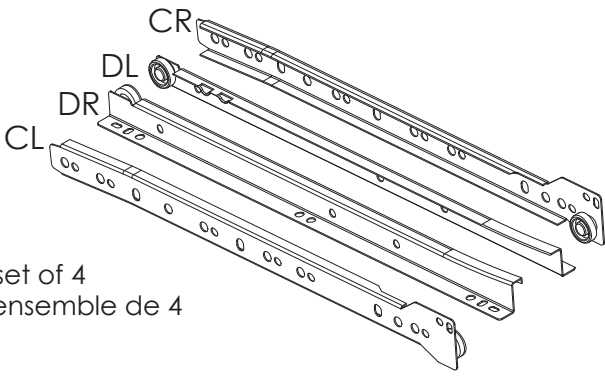
<p>4x # 0203</p> 	<p>12x # 0110</p> 	<p>12x # 0111</p> 	
<p>12x # 0205</p> 	<p>2x # 2210</p> 	<p>8x # 0204</p>  <p>For drawers Pour tiroirs</p>	
<p>6x # 0207</p> 	<p>4x # 0126</p> 	<p>4x # 1513</p> 	
<p>1x # 2300</p> 	<p>4x # 0303</p> 	<p>12x # 0105</p> 	
<p>2x set of 4 ensemble de 4 # 0909</p> 			

- 1** Using 12 screws # 0110, fasten the 4 drawer slides # 0909 (CL and CR) to the panels A2 and B2
Utilisez 12 vis # 0110 pour installer les 4 coulisses # 0909 (CL et CR) sur les panneaux A2 et B2

this screw first
Cette vis en premier

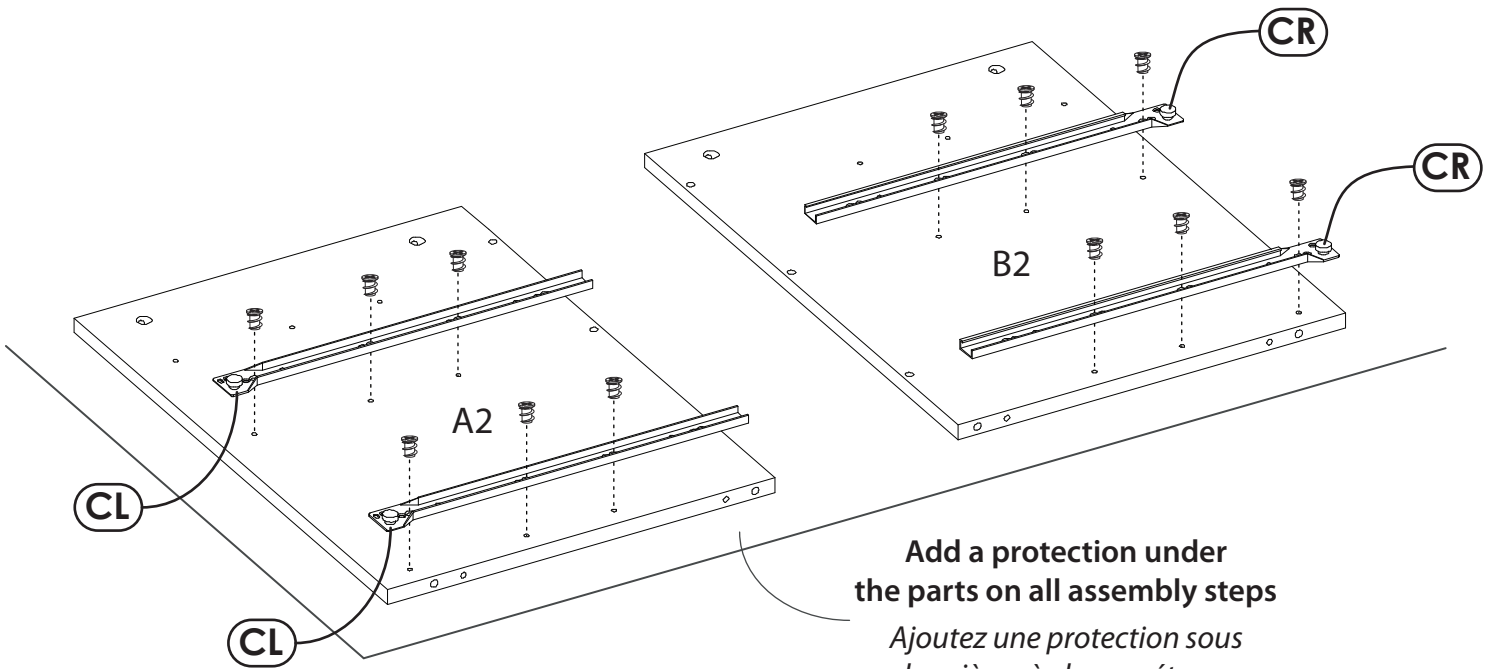
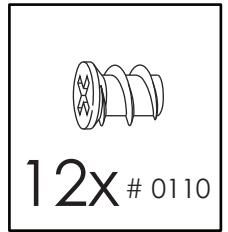
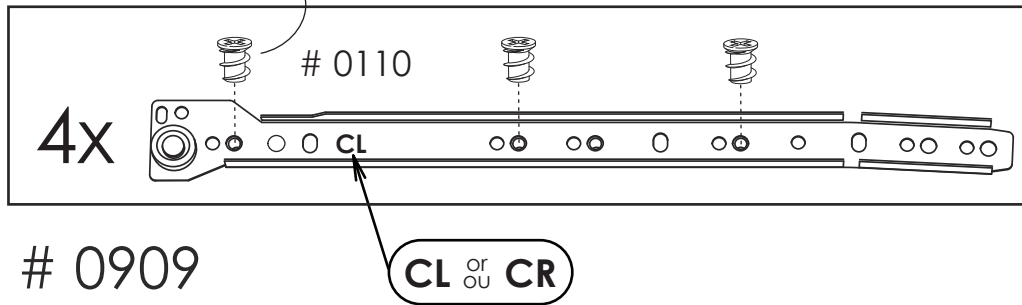

2 Install the 4 cam locks # 0203 into the panels A2 and B2
Installez les 4 excentriques # 0203 dans les panneaux A2 et B2

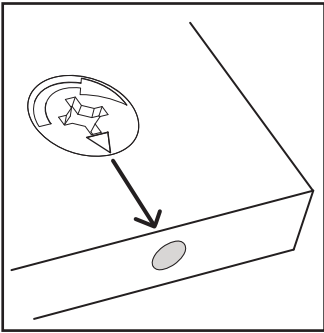

Press firmly into the hole
Pressez fermement dans la cavité

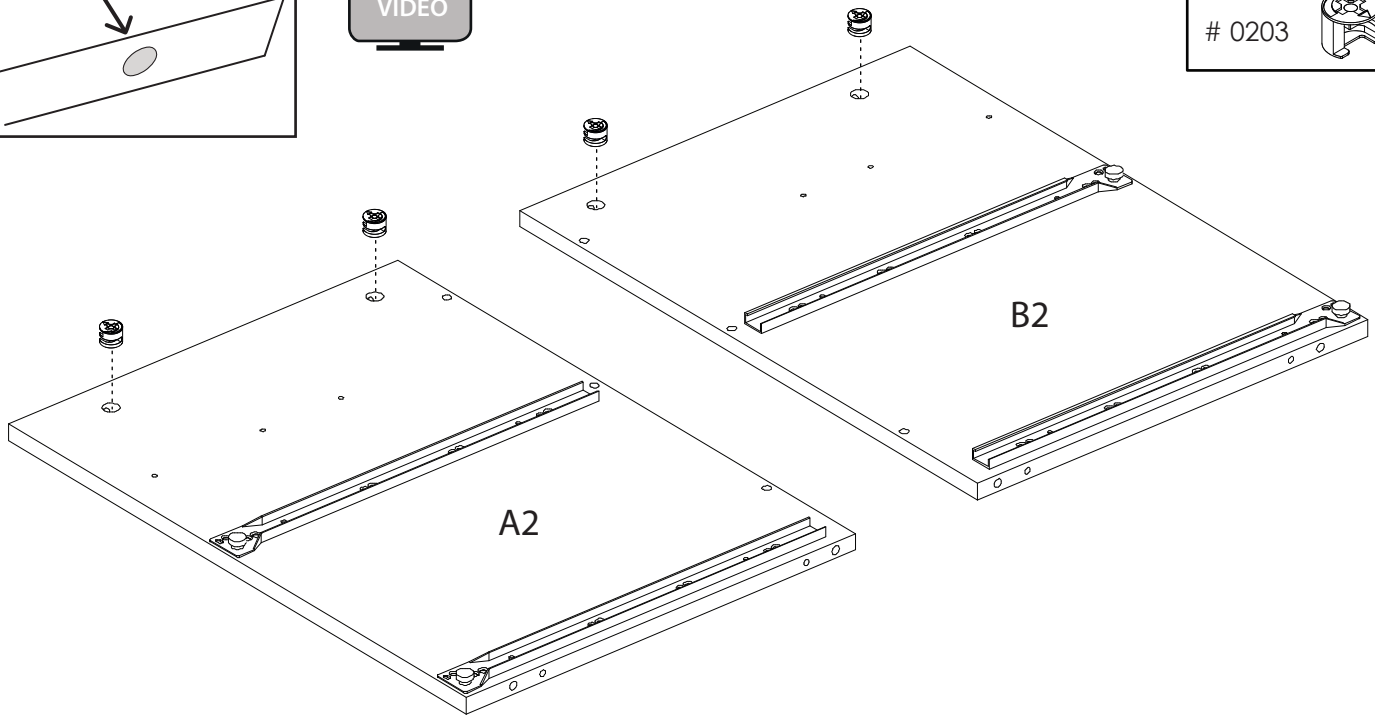

3 Insert the 6 wood dowels # 0207 into the panel D2
Insérez les 6 goujons de bois # 0207 dans le panneau D2

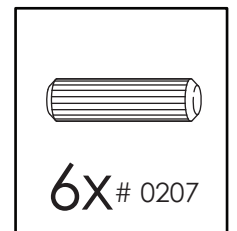
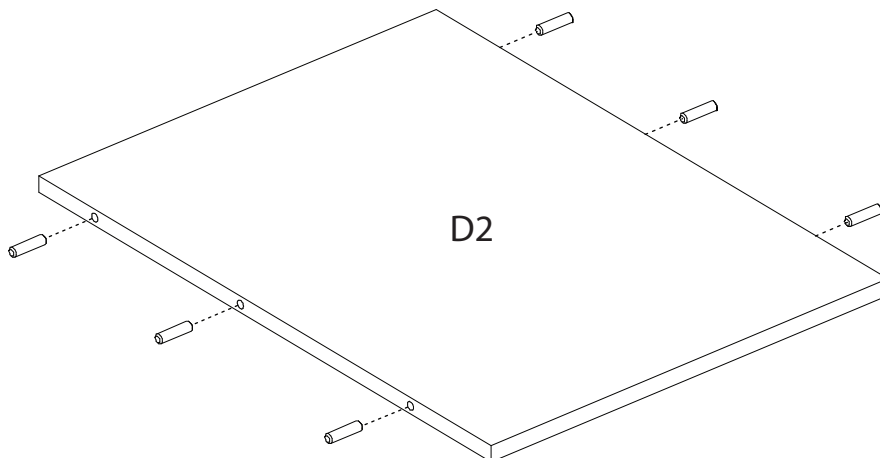

4 Install 4 screw bolts # 0205 into the panel C2
Installez 4 boulons vissables # 0205 dans le panneau C2

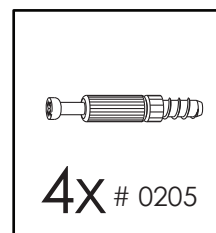
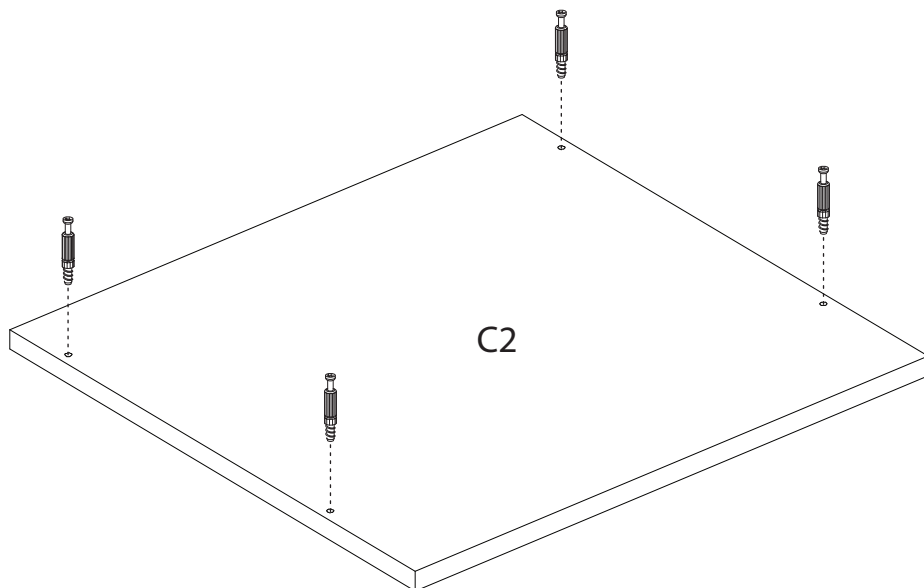

5 Fasten the panels A2 and B2 to the panel D2
Assemblez les panneaux A2 et B2 au panneau D2

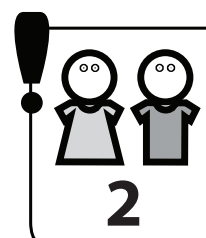
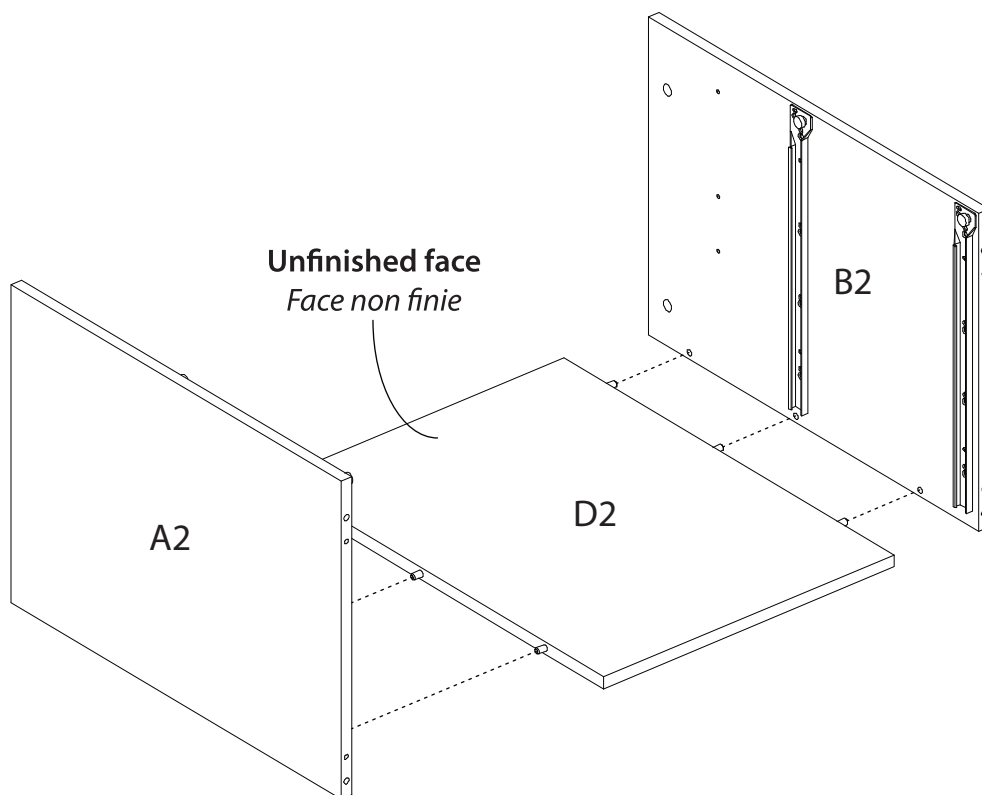

6 Use the Allen key # 2300 and 4 screws # 0111 to fasten the panel E2 to the pre-assembled panels A2-B2-D2

Utilisez la clé # 2300 et 4 vis # 0111 pour assembler le panneau E2 avec les panneaux pré-assemblés A2-B2-D2

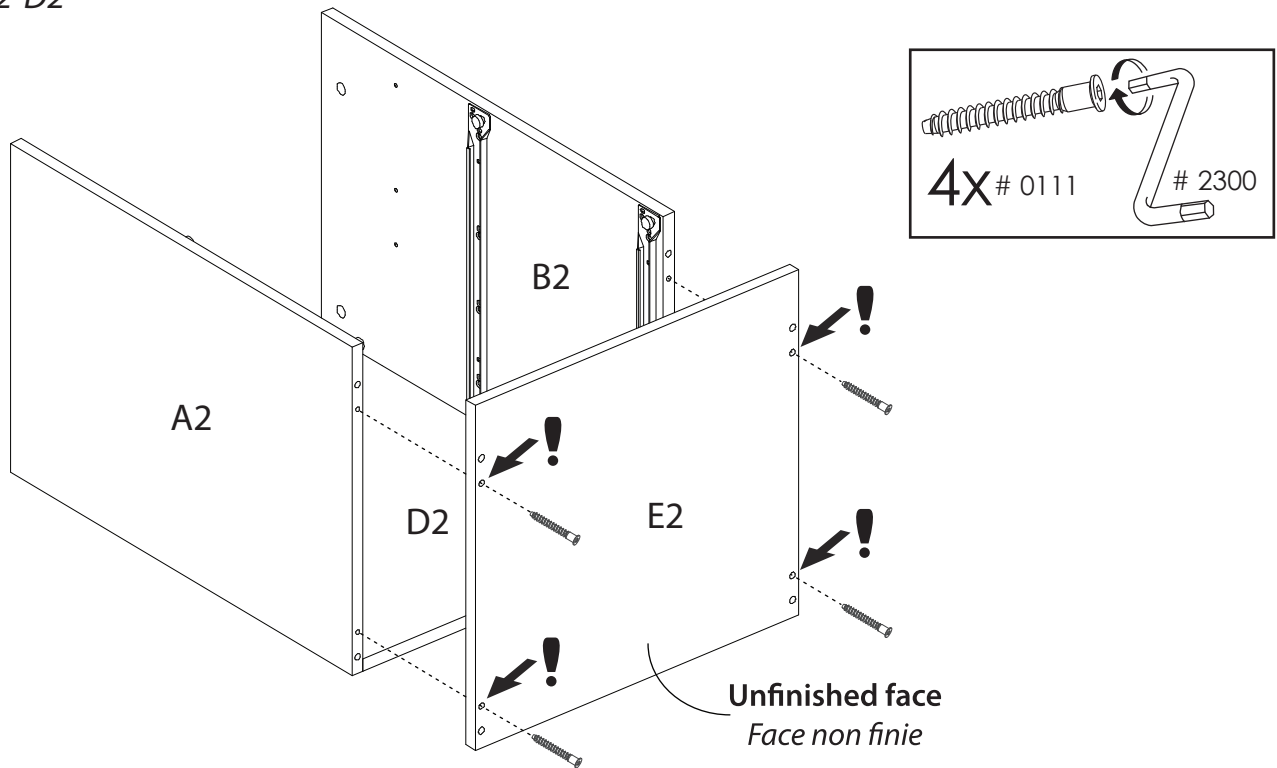

7 Fasten the panel C2 to the assembled unit. Then, tighten the 4 cam locks # 0203 located on panels A2 and B2. Insert the 4 wheel casters # 0303 into the 4 holes located on panel E2. Push each caster all the way to the large stem

Assemblez le panneau C2 avec l'unité déjà assemblée. Serrez ensuite les 4 excentriques # 0203 se trouvant sur les panneaux A2 et B2. Insérez les 4 roulettes # 0303 dans les 4 trous se trouvant sur le panneau E2. Poussez ensuite chaque roulette jusqu'à la tige plus large

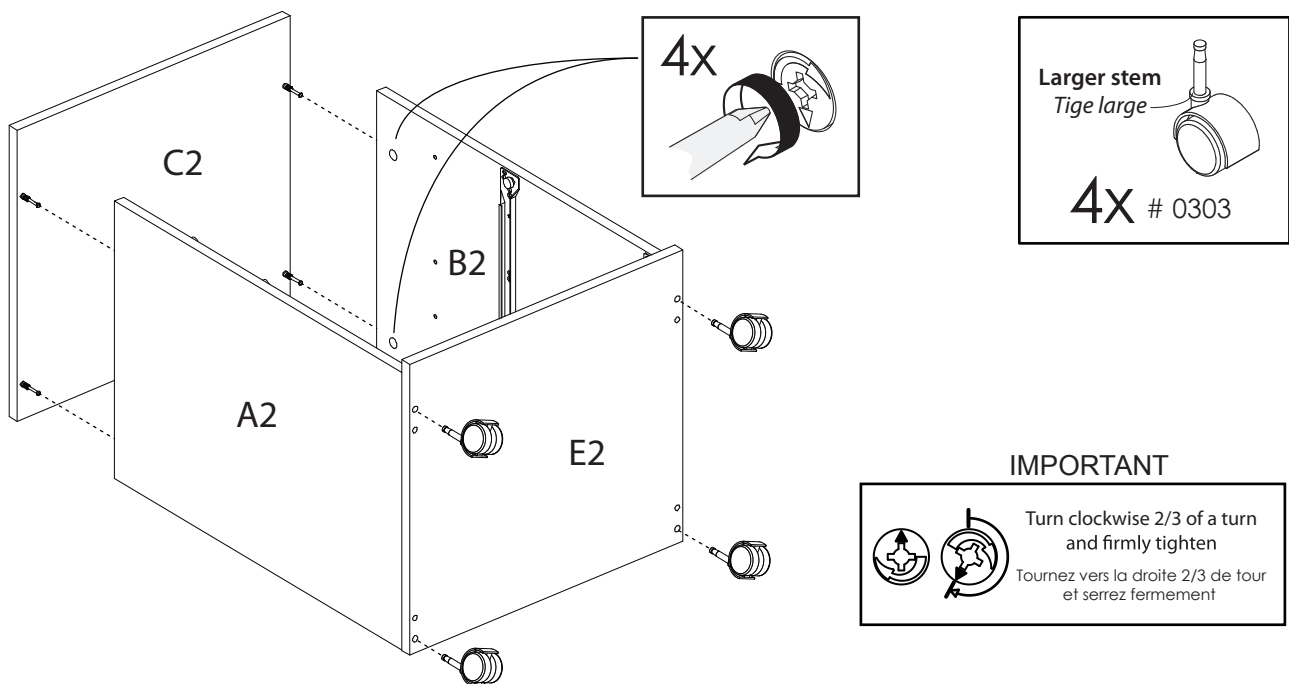

2x

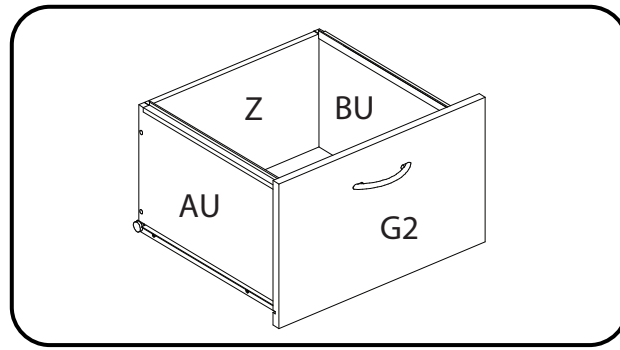

8 Install 4 small cam locks # 0204 into the panels AU and BU. Then, install 4 screw bolts # 0205 into the panel G2

Installez 4 mini excentriques # 0204 dans les panneaux AU et BU. Installez ensuite 4 boulons vissables # 0205 dans le panneau G2

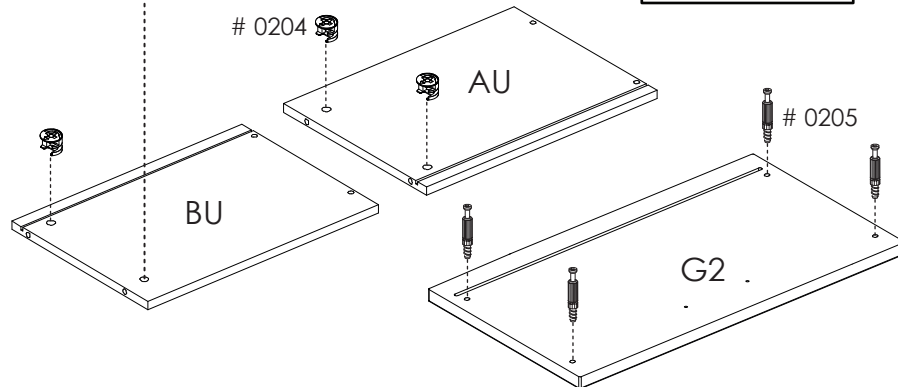
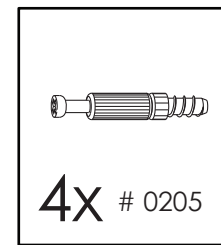
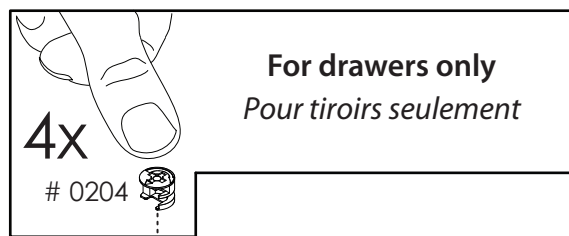
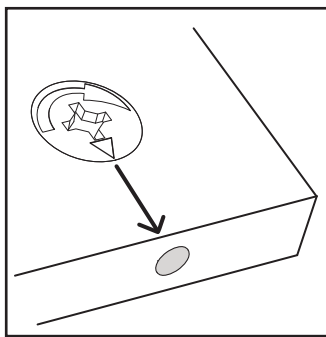

9 Fasten the panels AU and BU to the drawer front G2 and tighten the 4 cam locks # 0204 located on panels AU and BU

Assemblez les panneaux AU et BU à la façade G2 et serrez les 4 excentriques # 0204 se trouvant sur les panneaux AU et BU

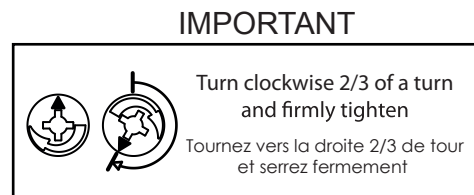
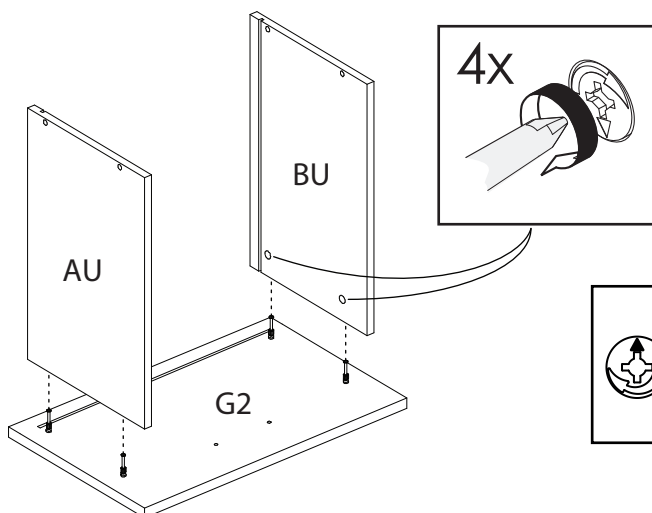

10 Insert the drawer bottom into the grooves located on panels AU and BU

Insérez le fond de tiroir dans les 2 rainures des panneaux AU et BU

VIDEO

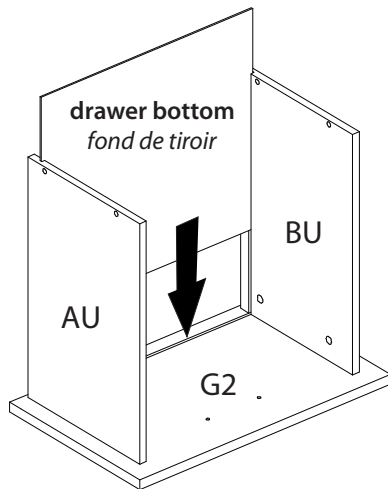

Drawer bottom must enter into the groove located on panel G2

Le fond de tiroir doit entrer dans la rainure se trouvant sur la façade G2

11 Use the Allen key # 2300 and 4 screws # 0111 to fasten the panel Z to the panels AU and BU

Utilisez la clé Allen # 2300 et 4 vis # 0111 pour fixer le panneau Z avec les panneaux AU et BU

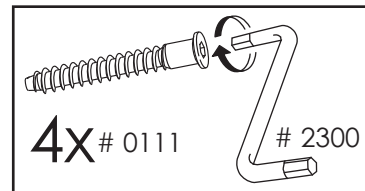
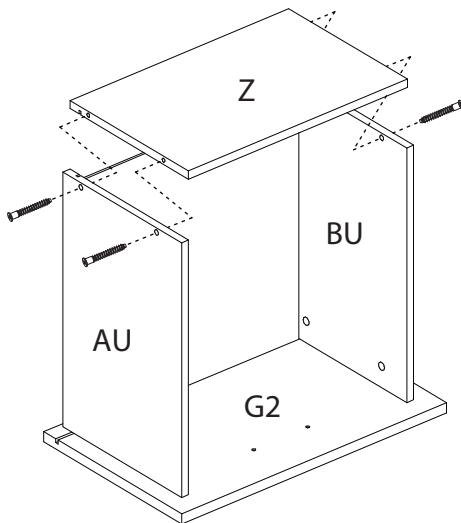

VIDEO

12 Use 6 screws # 0105 to fasten the 2 drawer slides # 0909 (DL and DR) to the panels AU and BU

Utilisez 6 vis # 0105 pour installer les 2 coulisses # 0909 (DL et DR) sur les panneaux AU et BU

0909

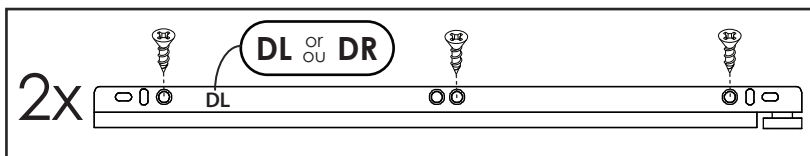

VIDEO

6x # 0105

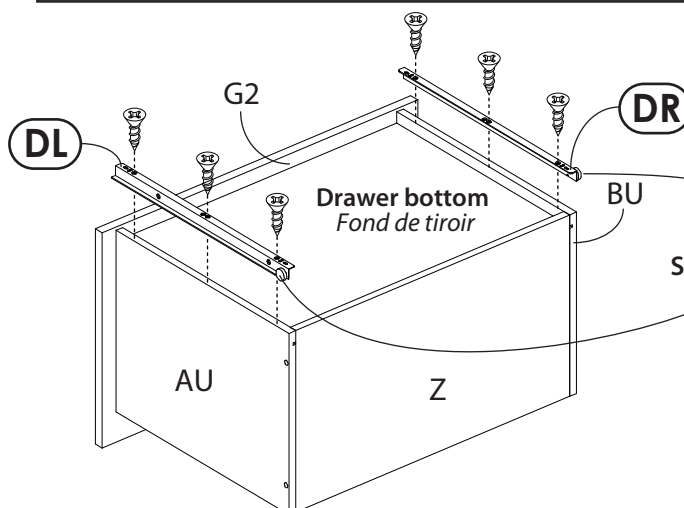

Slides rollers must face outwards
Les roulements doivent être alignés vers l'extérieur

13 Use 2 screws # 0126 to fasten 1 handle # 2210 to the drawer front G2. Then, insert the 2 file holders # 1513 on the upper edge of panels AU and BU

Utilisez 2 vis # 0126 pour fixer 1 poignée # 2210 sur la façade G2. Insérez ensuite les 2 supports à filière # 1513 sur le chant supérieur des panneaux AU et BU

Upper lip of extrusions
must face inwards

*Les lèvres supérieures des
extrusions doivent être
alignées vers l'intérieur*

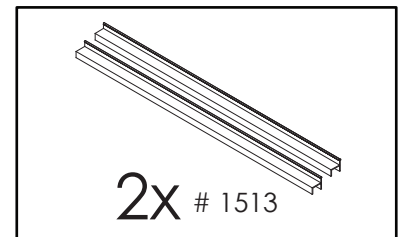
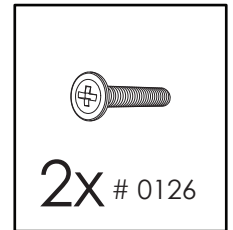
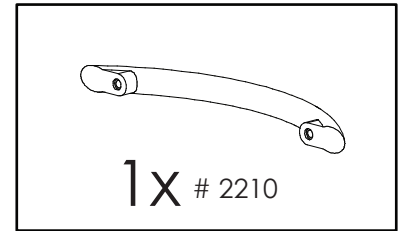
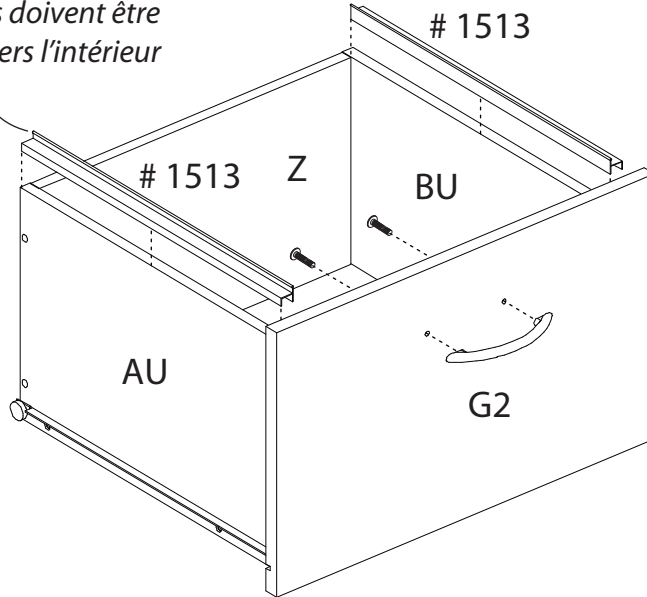

Repeat steps 8 to 13 for the second drawer
Répétez les étapes 8 à 13 pour le deuxième tiroir

14 Insert the 2 drawers into the unit

Insérez les 2 tiroirs dans l'unité

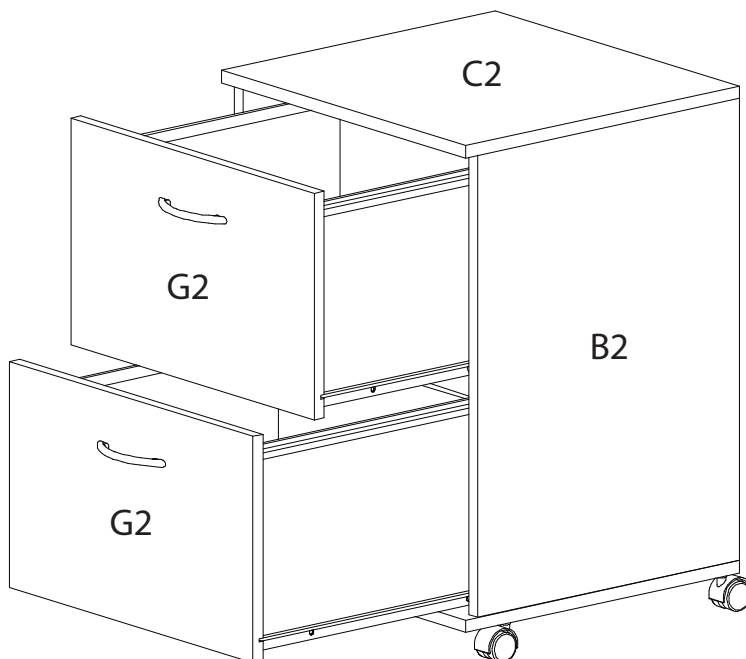

Limited 1 Year Warranty

Our products are warranted to the original purchaser against defects in material or workmanship for a period of 1 year from the date of purchase.

"Defects" as used in this warranty is defined as any imperfections that may impair the use of the furniture or product for which it was intended to.

This warranty is expressly limited to the replacement of defective furniture parts and/or components, subject to availability of stock. Assembly labor is excluded.

This warranty applies under conditions of normal use. It does not cover defects caused by improper assembly or disassembly, product modification, intentional damage, abuse, misuse, accidents, negligence or exposure to the elements. Our furniture products are not intended for outdoor use.

This warranty is only applicable in Canada and the USA.

We reserve the right to request proof of purchase from an authorized retailer as well as any other proofs to document a warranty claim.

This warranty is explicit on the limits of us liability and entitles the original purchaser to specific rights. Any warranty defined by law in your state/province is limited to 1 year. Should the law in your state or province differ from the above, it will not apply.